



LB1955

Three-Phase Brushless Motor Driver

Functions

- The LB1955 is a 3-phase brushless motor driver IC that is optimal for applications such as driving the drum motor in VCRs.

Features

- Current linear drive
- FG and PG free
- Single-voltage power supply
- Built-in AGC circuit
- Built-in thermal shutdown circuit

Package Dimensions

unit: mm

3222-HSOP28

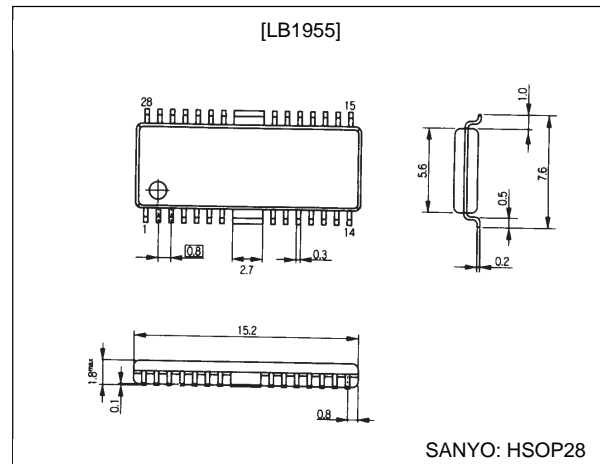
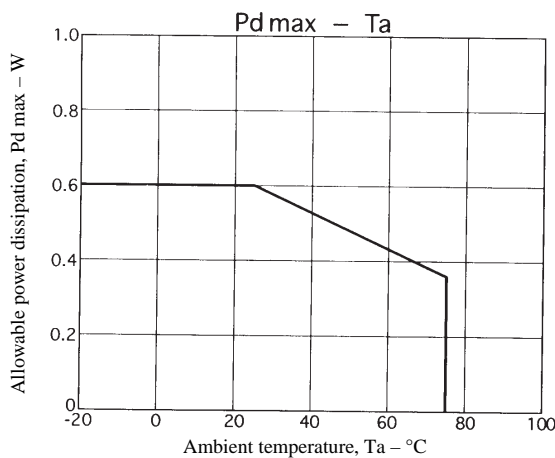

Specifications

Absolute Maximum Ratings at Ta = 25°C

Parameter	Symbol	Conditions	Ratings	Unit
Maximum supply voltage	V _{CCmax}		14.5	V
Maximum output current	I _{OUT}		1.0	A
Allowable power dissipation	Pdmax	Independent device	0.60	W
Operating temperature	Topr		-20 to +75	°C
Storage temperature	Tstg		-55 to +150	°C

Allowable Operating Ranges at Ta = 25°C

Parameter	Symbol	Conditions	Ratings	Unit
Supply voltage	V _{CC}		10.2 to 13.8	V
Hall input amplitude	V _{hall}	At the input	70 to 500	mVp-p
VC input voltage	V _C		0 to 5	V

SANYO Electric Co.,Ltd. Semiconductor Bussiness Headquarters
 TOKYO OFFICE Tokyo Bldg., 1-10, 1 Chome, Ueno, Taito-ku, TOKYO, 110 JAPAN

LB1955

Electrical Characteristics at $T_a = 25^\circ\text{C}$, $V_{CC} = 12\text{ V}$

Parameter	Symbol	Conditions	Ratings			Unit	
			min	typ	max		
[Power Supply]							
Current drain	I_{CC}	$V_C = 0\text{ V}$, $LCTR = 6\text{ V}$	7.0	10.0	13.0	mA	
IC internal power supply	V_{REF}		4.75	5.0	5.25	V	
[Output]							
Output saturation voltage	$V_{O(sat)1}$	$I_O = 400\text{ mA}$ $V_C = 5\text{ V}$, $R_f = 0\ \Omega$	Sink side			0.4	V
			Source side				1.5
Output saturation voltage 2	$V_{O(sat)2}$	$I_O = 800\text{ mA}$ $V_C = 5\text{ V}$, $R_f = 0\ \Omega$	Sink side			0.7	V
			Source side				2.0
3-phase output current ripple	I_{or}	$I_O = 100\text{ mA}$, $R_f = 0.47\ \Omega$	-5			+5	%
[Hall Amplifier]							
Input offset voltage	V_{Hoff}		-20			+20	mV
Input bias current	I_{Hb}	$V_{AGC} = 1.4\text{ V}$	U_{IN}			10	μA
			V_{IN}, W_{IN}			5	μA
Common-mode input voltage range	V_{HCM}		2.2			5.0	V
[Control]							
VC pin input bias current	I_{VCb}	$V_C = 0\text{ V}$	-10	-1.3			μA
Control start voltage	V_{THVC}	$R_f = 0.47\ \Omega$, $I_O \geq 10\text{ mA}$ With the Hall input logic fixed	2.25	2.5	2.75		V
Open-loop control gain	G_{MVC}	$R_f = 0.47\ \Omega$, $\Delta I_O = 200\text{ mA}$ With the Hall input logic fixed and VG shorted to RF	0.72	0.9	1.08		A/V
[PG]							
PG Hall amplifier input offset voltage	V_{PGoff}	Design target	-10			+10	mV
Peak hold charge current	I_{SHCHG}	(U, V, W) = (L, L, H)		30			μA
PG comparator threshold	THPG	Design target*		117			%
PG output high-level voltage	V_{PGH}		4.5			5.2	V
PG leakage current	I_{LEAKPG}		-10	0		+10	μA
[FG]							
Back emf Schmitt input hysteresis width	V_{SCHG}	In the back emf Schmitt input increasing direction, Design target		100			mV
		In the back emf Schmitt input decreasing direction, Design target		0			mV
Ringing canceller Schmitt input hysteresis width	V_{SCHR}	In the Schmitt input increasing direction, Design target		180			mV
		In the Schmitt input decreasing direction, Design target	-20	0	+20		mV
FG output high-level voltage	V_{FGH}	$FGR = 0\text{ V}$	4.5			5.2	V
FG leakage current	I_{LEAKFG}		-10	0		+10	μA
[TSD]							
Thermal shutdown operating temperature	TTSD	Design target		180			$^\circ\text{C}$
Thermal shutdown temperature hysteresis width	ΔTSD	Design target		15			$^\circ\text{C}$

Note: * is provided for when X is the peak value at the 60° position of the lower side of the U_{IN1} Hall amplifier input: $\text{THPG} = 1.17X$.

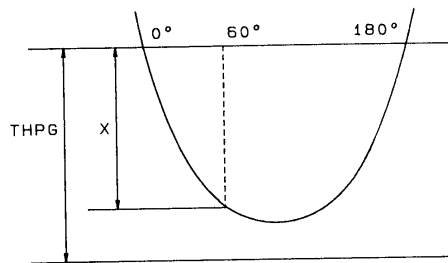

A05606

Pin Assignment

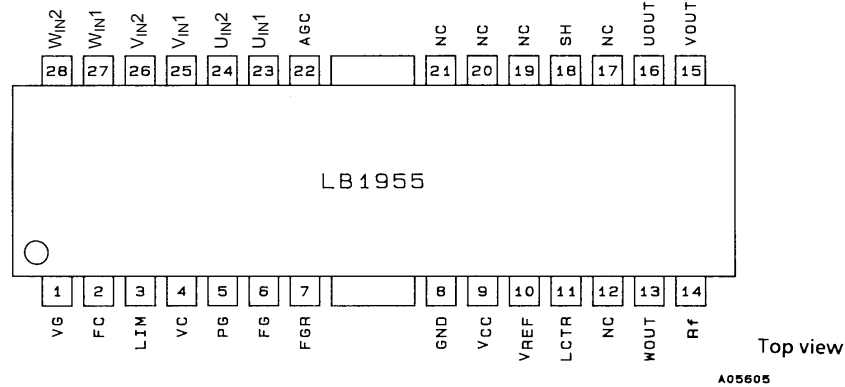

Truth table

	Source → sink	Hall input logic		
		U	V	W
1	W phase → V phase	H	H	L
2	W phase → U phase	H	L	L
3	V phase → U phase	H	L	H
4	V phase → W phase	L	L	H
5	U phase → W phase	L	H	H
6	U phase → V phase	L	H	L

Note: The Hall input "H" and "L" values are defined as follows: "H" means that for that phase the (+) input is higher than the (-) input, and "L" means that for that phase the (+) input is lower than the (-) input. However, note that an input potential difference corresponding to the Hall to output gain is required.

Timing Charts

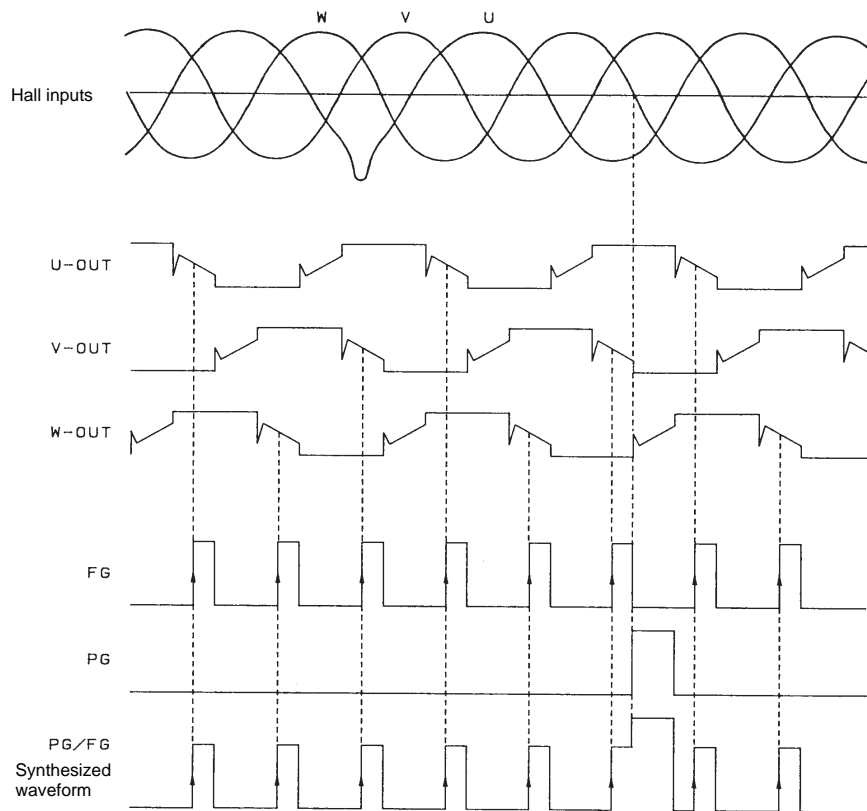

Note: The Hall inputs are defined as follows: $U = U_{IN1} - U_{IN2}$, $V = V_{IN1} - V_{IN2}$, and $W = W_{IN1} - W_{IN2}$. Inputs to the Hall input pins must be applied in the phase order shown in the timing chart.

Pin Functions

Pin No.	Pin	Function
23, 24	U _{IN1} , U _{IN2}	U phase Hall element input
25, 26	V _{IN1} , V _{IN2}	V phase Hall element input
27, 28	W _{IN1} , W _{IN2}	W phase Hall element input
16	UOUT	U phase output
15	VOUT	V phase output
13	WOUT	W phase output
11	LCTR	Pin connected to the center points of the coils that are Y-connected to the U, V, and W outputs.
9	V _{CC}	Power supply
10	V _{REF}	Reference voltage output
8	GND	GND
14	Rf	Output current detection
1	VG	Closed loop control gain switching
2	FC	Speed control loop frequency characteristics correction
3	LIM	Output current limit setting
4	VC	Speed control
5	PG	PG waveform output
6	FG	FG waveform output (FGR shorted to GND)
7	FGR	PG/FG synthesized output (FGR shorted to PG)
18	SH	PG waveform sample-and-hold circuit capacitor connection
22	AGC	Connection for the capacitor used by the AGC circuit, which holds the input gain at a fixed level.
12, 17, 19 20, 21	NC	No connection

Recommended Special Magnetization Waveforms

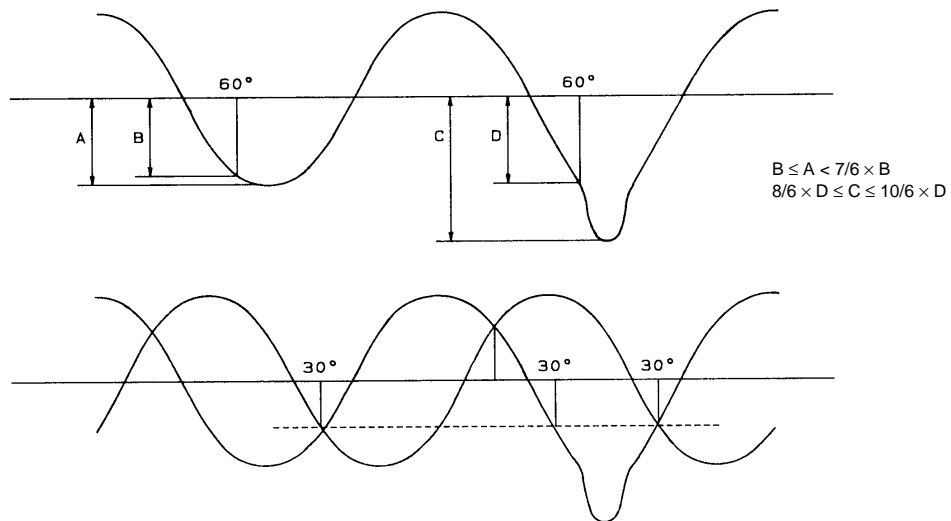

A05608

Note: Note that the intersections between the special magnetization and general waveforms and the intersections between pairs of general waveforms must be set up to be 30° apart.

Hall Input Order

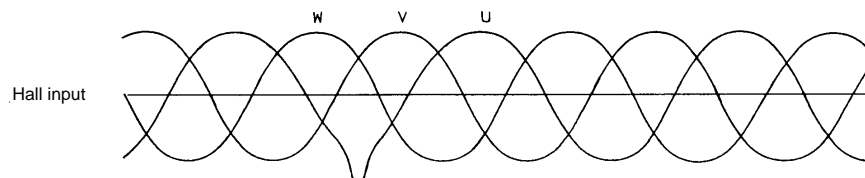

A05609

Note: The Hall input order must be set up to be W → V → U.

VG and LIM Pin Usage

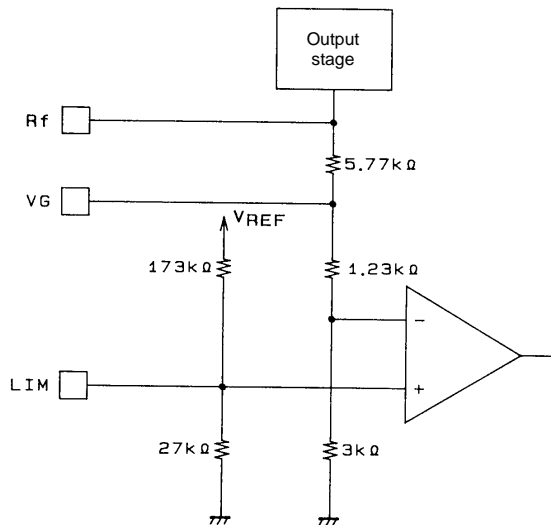

LIM pin: Open
 VG - Rf: Shorted
 $G_m = 0.423/R_f$ (A/V)
 (Closed loop control gain)
 $I_{lim} = (V_{REF} \times 27/200 - 0.2) \times 4.23/3/R_f$
 (Current limit)

VG pin: Open
 $G_m = 1/R_f$ (A/V)
 (Closed loop control gain)
 $I_{lim} = (V_{REF} \times 27/200 - 0.2) \times 10/3/R_f$
 (Current limit)

LIM - VREF: Shorted
 No current limit.

A05610

Note: This current limiting function is for protection against unusual and abnormal currents. If a current limit level below the rated current is set, this will, inversely, result in heat generation within the IC.
 When the LIM pin is open, VG is shorted to Rf, and $R_f = 0.47 \Omega$, this will result in a current limit level of about 1.3 to 1.4 A. If this limit falls under the rated value due to mode changes or changes in the value of the Rf resistor, set the current limit to an appropriate value by applying to the LIM pin a voltage that is divided from the VREF to ground potential by resistors of a few kΩ. Alternatively, short the LIM pin to VREF to defeat the current limit function.

PG and FG Pin Output Circuits

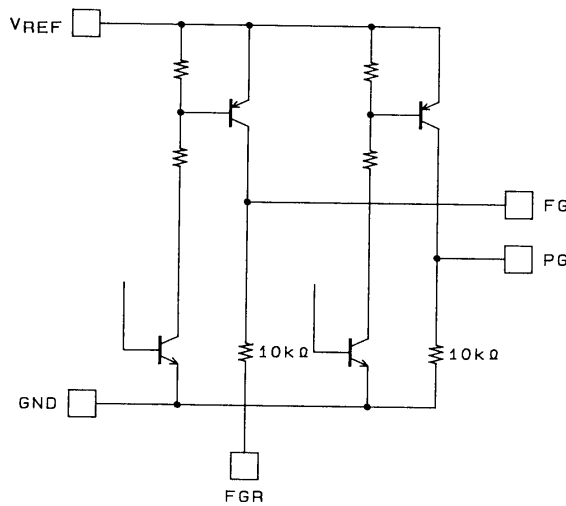

A05611

FG (FGR shorted to ground)

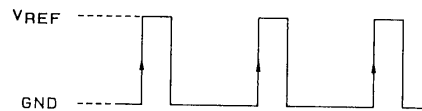

PG

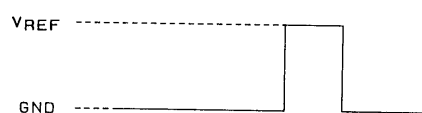

PG (FGR shorted to PG)

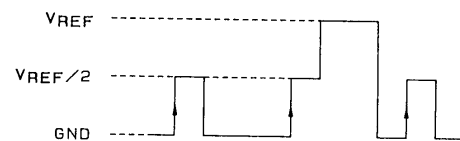

A05612

Block Diagram

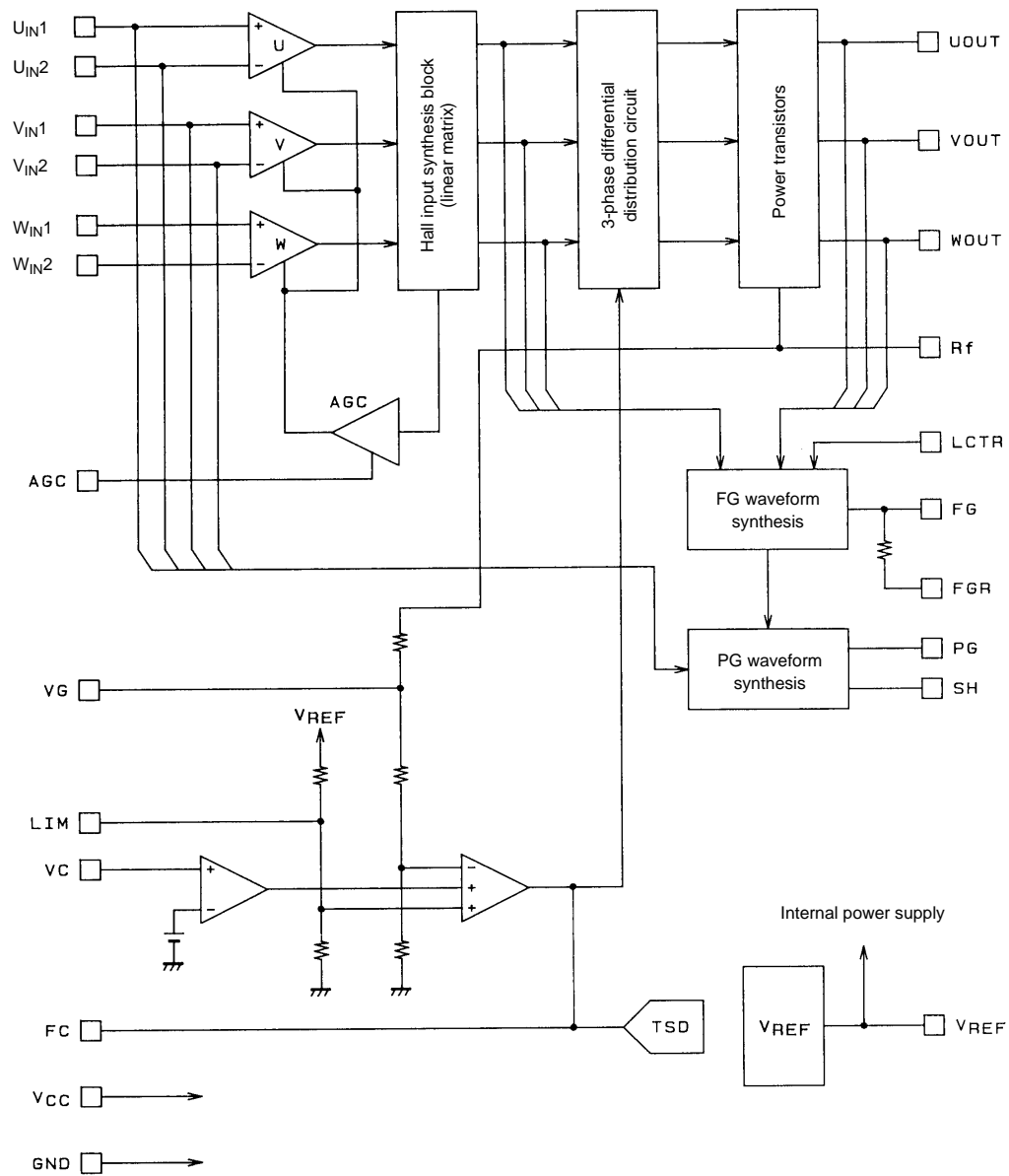

A05613

Sample Application Circuit

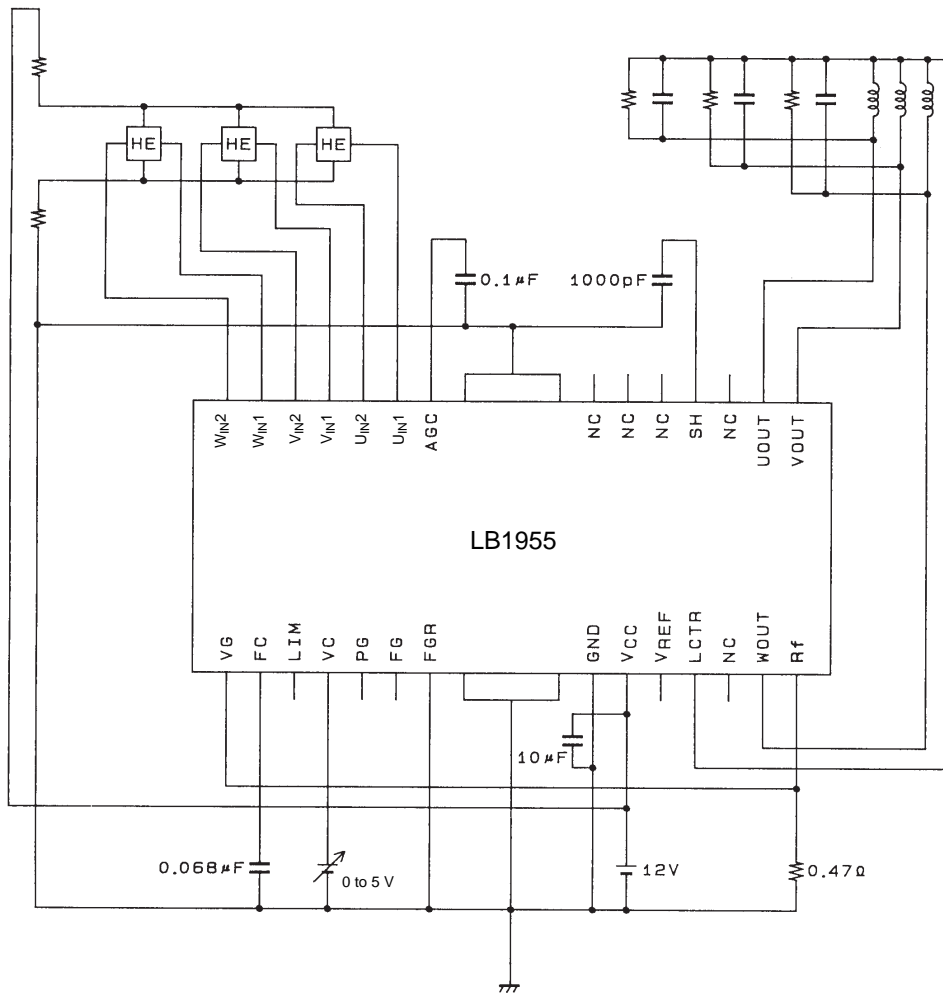

A05614

- No products described or contained herein are intended for use in surgical implants, life-support systems, aerospace equipment, nuclear power control systems, vehicles, disaster/crime-prevention equipment and the like, the failure of which may directly or indirectly cause injury, death or property loss.
- Anyone purchasing any products described or contained herein for an above-mentioned use shall:
 - ① Accept full responsibility and indemnify and defend SANYO ELECTRIC CO., LTD., its affiliates, subsidiaries and distributors and all their officers and employees, jointly and severally, against any and all claims and litigation and all damages, cost and expenses associated with such use:
 - ② Not impose any responsibility for any fault or negligence which may be cited in any such claim or litigation on SANYO ELECTRIC CO., LTD., its affiliates, subsidiaries and distributors or any of their officers and employees jointly or severally.
- Information (including circuit diagrams and circuit parameters) herein is for example only; it is not guaranteed for volume production. SANYO believes information herein is accurate and reliable, but no guarantees are made or implied regarding its use or any infringements of intellectual property rights or other rights of third parties.

This catalog provides information as of July, 1997. Specifications and information herein are subject to change without notice.