

**LB1939T**

2 Channel H Bridge Constant Voltage/ Constant Current Driver IC

Overview

The LB1939T is a two-phase excitation bipolar stepping motor driver that features low voltage operation, a low saturation voltage, and low power consumption. It supports constant voltage and constant current drive, can control two iris motors, and is optimal for shutter, iris, and AF drive in 3 V battery operated still digital cameras and other battery operated equipment.

Features

- Low-voltage drive
 - Dual power supply operation: $V_S = 1.6$ to 7.5 V, $V_{DD} = 1.9$ to 6.5 V
 - Single power supply operation: $V_S = V_{DD} = 1.9$ to 7.5 V
- Low saturation voltage output: $V_{osat} = 0.3$ V at $I_O = 200$ mA
- Supports constant voltage and constant current drive
- Built-in reference voltage circuit ($V_{ref} = 0.9$ V)
- Miniature, thin form package (Thickness $t = 1.1$ mm)

Package Dimensions

unit: mm

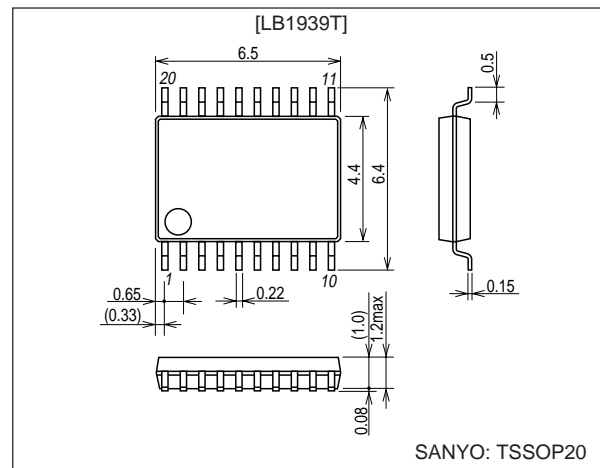
3246-TSSOP20

Specifications

Absolute Maximum Ratings at $T_a = 25^\circ\text{C}$

Parameter	Symbol	Conditions	Ratings	Unit
Maximum supply voltage	V_{Bmax}	$VS1, VS2, V_{DD}$	-0.3 to +10.5	V
Applied output voltage	V_{OUT}	OUT1, 2, 3, 4	-0.3 to +10.5	V
Maximum output current: OUT1, 2, 3, and 4	I_{Omax}	$t \leq 10$ ms	400	mA
Applied input voltage	V_{IN}	ENA, IN, VC	10.5	V
Allowable power dissipation	P_{dmax}	When mounted on a printed circuit board*	0.8	W
Operating temperature	T_{opr}		-20 to +85	$^\circ\text{C}$
Storage temperature	T_{stg}		-55 to +150	$^\circ\text{C}$

Note: Circuit board: $114.3 \times 76.1 \times 1.6$ mm³ glass epoxy board

■ Any and all SANYO products described or contained herein do not have specifications that can handle applications that require extremely high levels of reliability, such as life-support systems, aircraft's control systems, or other applications whose failure can be reasonably expected to result in serious physical and/or material damage. Consult with your SANYO representative nearest you before using any SANYO products described or contained herein in such applications.

■ SANYO assumes no responsibility for equipment failures that result from using products at values that exceed, even momentarily, rated values (such as maximum ratings, operating condition ranges, or other parameters) listed in products specifications of any and all SANYO products described or contained herein.

SANYO Electric Co., Ltd. Semiconductor Company
TOKYO OFFICE Tokyo Bldg., 1-10, 1 Chome, Ueno, Taito-ku, TOKYO, 110-8534 JAPAN

22704TN (OT) No. 6194-1/7

LB1939T

Allowable Operating Conditions at $T_a = 25^\circ\text{C}$

Parameter	Symbol	Conditions	Ratings			Unit
			min	typ	max	
Operation guaranteed voltage range 1	V_{OPR1}	V_{DD} system, $V_S = 2.0\text{ V}$	1.9		6.5	V
Operation guaranteed voltage range 2	V_{OPR2}	VS system, $V_{DD} = 5.0\text{ V}$	1.6		7.5	V
Input low-level threshold voltage	V_{IL}	ENA1, ENA2, IN1, IN2	-0.3		+1.0	V
Input high-level threshold voltage	V_{IH}	ENA1, ENA2, IN1, IN2	2.0		6.0	V

Electrical Characteristics at $T_a = 25^\circ\text{C}$, $V_S = 3.0\text{ V}$, $V_{DD} = 5.0\text{ V}$

Parameter	Symbol	Conditions	Ratings			Unit
			min	typ	max	
Standby mode current drain	I_{STB}	$V_S = V_{DD} = 6.5\text{ V}$		0.1	1.0	μA
[Regulator Output Circuit]						
V_{REF} output voltage	V_{REF}	$I_{OL} = 0$ to 1 mA	0.85	0.9	0.95	V
SV_{DD} output voltage	SV_{DD}	$I_{OL} = 10\text{ mA}$	4.7	4.8		V
[H Bridge Output Circuit]						
OUT pin output saturation voltage 1 (Saturation control mode)	V_{osat1}	$V_{DD} = 5.0\text{ V}$, $VC = SV_{DD}$, $V_S = 2.0\text{ V}$ $I_O = 200\text{ mA}$ (PNP transistor side)		0.20	0.30	V
OUT pin output saturation voltage 2 (Saturation control mode)	V_{osat2}	$V_{DD} = 5.0\text{ V}$, $VC = SV_{DD}$, $V_S = 2.0\text{ V}$ $I_O = 200\text{ mA}$ (NPN transistor side)		0.10	0.15	V
OUT pin output voltage 1 (Constant voltage control mode)	V_{OUT1}	$V_{DD} = 6.0\text{ V}$, $VC = 1.5\text{ V}$, $V_S = 3.5\text{ V}$ $I_O = 200\text{ mA}$ (PNP transistor side)	2.8	2.9	3.0	V
OUT pin output voltage 2 (Constant voltage control mode)	V_{OUT2}	$V_{DD} = 6.0\text{ V}$, $VC = V_{REF}$, $V_S = 2.0\text{ V}$ $I_O = 200\text{ mA}$ (PNP transistor side)	1.65	1.75	1.85	V
OUT pin output current 1 (Constant current control mode)	I_{OUT1}	$V_{DD} = 6.0\text{ V}$, $VC = 0.9\text{ V}$, $V_S = 3.5\text{ V}$ $RL = 5\ \Omega$ (between OUT and OUT), $RFB = 1\ \Omega$	197	210	223	mA
OUT pin output current 2 (Constant current control mode)	I_{OUT2}	$V_{DD} = 6.0\text{ V}$, $VC = V_{REF}$, $V_S = 2.0\text{ V}$ $RL = 5\ \Omega$ (between OUT and OUT), $RFB = 1\ \Omega$	189	210	231	mA
VS system operating current drain 1	I_{S1}	$VC = SV_{DD}$		4	7	mA
VS system operating current drain 2	I_{S2}	$VC = V_{REF}$		1.5	3	mA
V_{DD} system operating current drain 1	I_{DD1}	$VC = SV_{DD}$ ENA1 = 2 V		4	7	mA
V_{DD} system operating current drain 2	I_{DD2}	$VC = V_{REF}$ ENA1 = 2 V		4	7	mA
VC input voltage range	VC		0.1		7	V
VC input current	IVC	$V_{DD} = 6.0\text{ V}$, $V_S = 2.0\text{ V}$, $VC = 5.0\text{ V}$	0	50	100	μA
[Control Input Circuit]						
Control pin maximum input current	I_{IH}	$V_{IH} = 5.5\text{ V}$		70	100	μA
	I_{IL}	$V_{IL} = \text{GND}$	-1		0	μA

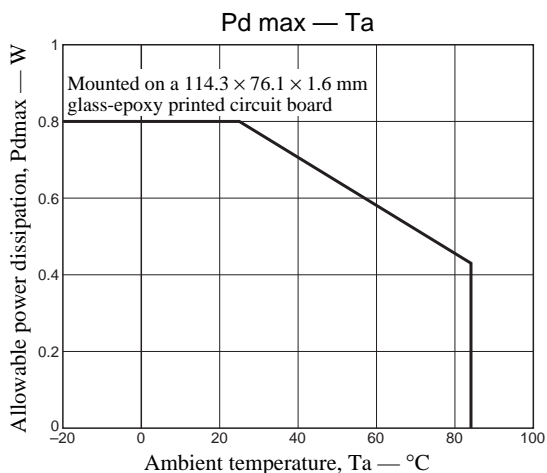

LB1939T

Truth Table

Input				Output				SVDD	Mode
ENA		IN		OUT					
1	2	1	2	1	2	3	4		
L	L								Standby mode (zero current drain)
H		H		L	H			on	Channel 1: reverse
		L		H	L			on	Channel 1: forward
	H		H			L	H	on	Channel 2: reverse
			L			H	L	on	Channel 2: forward
Blank entries indicate "don't care" states.				Blank entries indicate off states.					

Pin Assignment

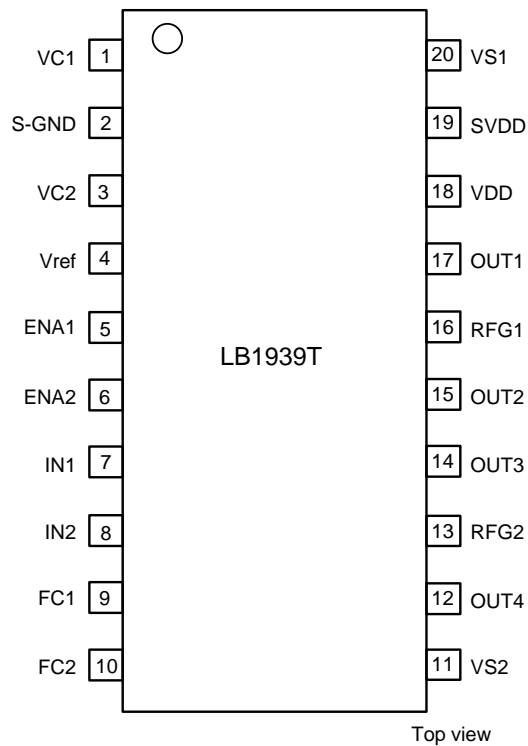

Block Diagram

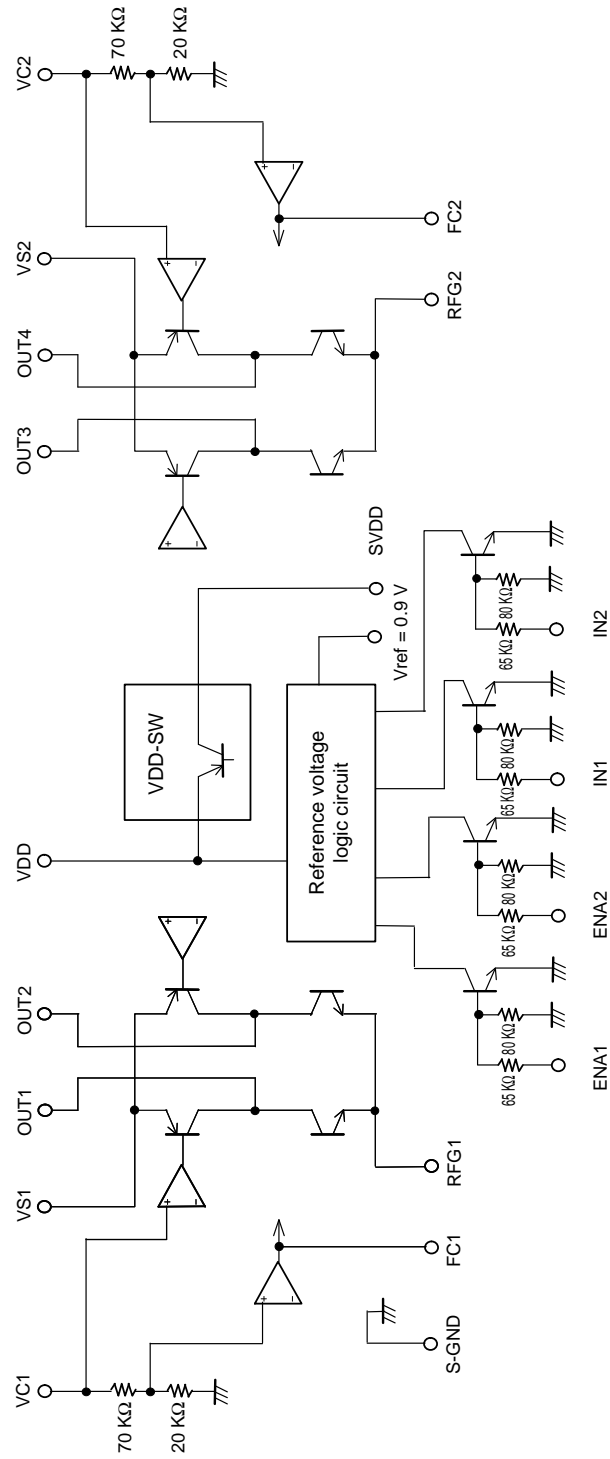

Application Circuit Example 1

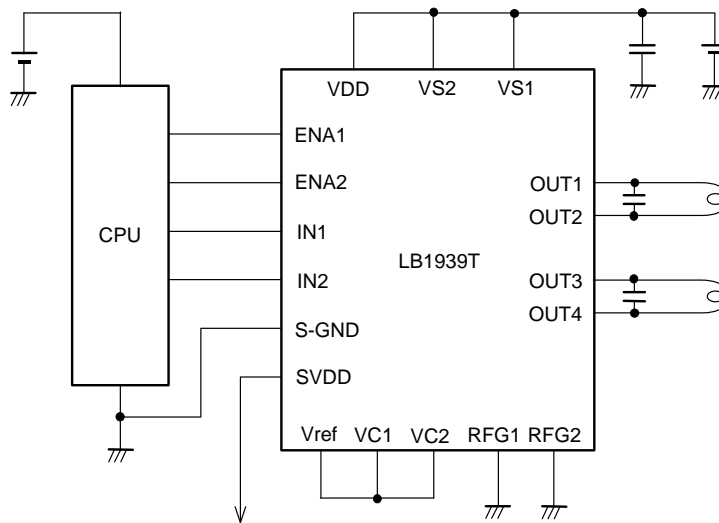

Constant voltage control mode: OUT outputs a 1.75 V, which is $V_{ref} (0.9\text{ V}) \times 1.95$.
 *: FC1 and FC2 are left open.

Application Circuit Example 2

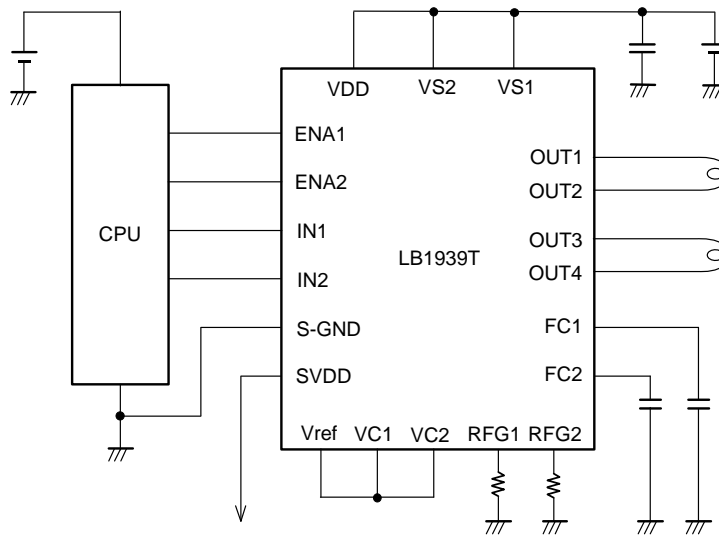

Constant current control mode: The RFG voltage is controlled so that $V_{ref}/4.5 = 0.2\text{ V}$.
 Therefore, when R_{fB} is $1\ \Omega$, the circuit operates in constant current drive with $I_{coil} = 0.2\text{ V}/1\ \Omega = 200\text{ mA}$.

*: There are no magnitude constraints on the inputs (ENA, IN) and the supply voltages (V_{DD} , V_S).
 For example, the IC can be operated at $V_{IN} = 5\text{ V}$, $V_{DD} = 3\text{ V}$, and $V_S = 2\text{ V}$.

Application Circuit Example 3

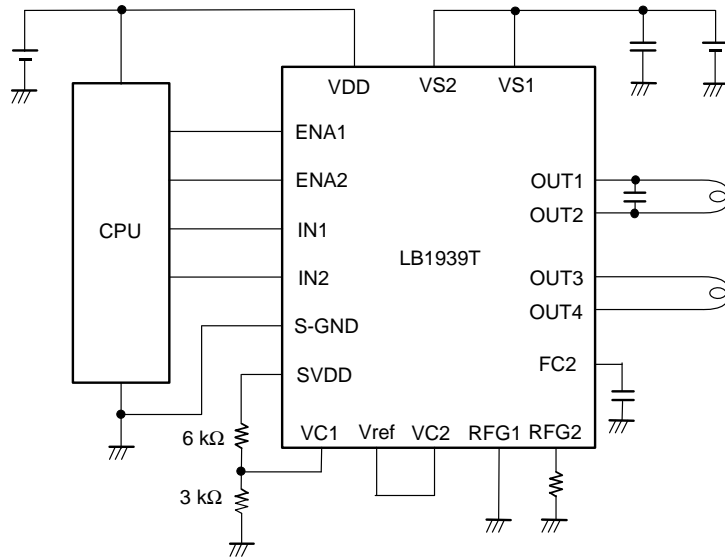

Channel 1 operates in constant voltage control mode: OUT outputs $V_{DD} \times 3K/(3K + 6K) \times 1.95$
 Channel 2 operates in constant current control mode: The RFG voltage is controlled so that $V_{ref}/4.5 = 0.2 V$.
 * : FC1 is left open.

Notes on Constant Current Control Settings

The LB1939T constant current control circuit has the structure shown in the figure at the right. The voltage input to the VC pin is resistor divided internally (by 70 kΩ and 20 kΩ resistors) to 1/4.5 and input to the plus (+) input of the constant current control amplifier as reference.

The minus (-) input of this constant current control amplifier is connected, through the wire bond resistor Rb (= 0.1 Ω), to the RFG pin. The constant current control circuit operates by comparing the voltage generated by the external current detection resistor connected to the RFG pin and the reference voltage mentioned above.

Note that the voltage at VA will be that given by the following formula since the bias current Ib (= 1.5 μA) flows from the constant current control amplifier plus (+) input during constant current control operation.

$$VA = VC/4.5 + Ib \times 20 \text{ k}\Omega$$

$$= VC/4.5 + 0.03$$

Therefore, the logical expression for setting the constant current Iout is as follows.

$$I_{out} = VA/(RFB + Rb)$$

$$= (VC/4.5 + 0.03) / (RFB + Rb) \dots\dots(1)$$

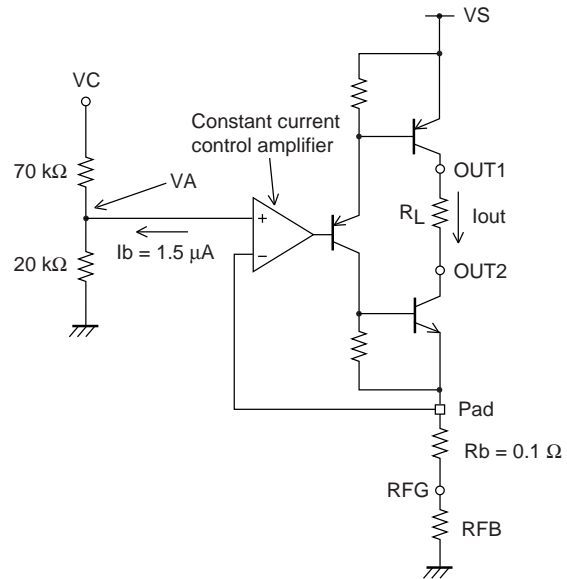

A13864

Constant Current Control Usage Notes

This IC supports both constant current control and constant voltage control modes. However, since both of these control circuits operate at all times, certain of the limitations imposed by the constant voltage control circuit apply when using constant current control.

For example, if constant current control is used with the application circuit shown in figure 2, if $V_C = 0.9\text{ V}$ ($= V_{\text{ref}}$) and $R_{\text{FB}} = 1\ \Omega$, then the output current can be calculated as follows from (1) on the previous page.

$$\begin{aligned} I_{\text{out}} &= (0.9/4.5 + 0.03) / (1 + 0.1) \\ &= 0.23/1.1 \\ &\approx 0.209\text{A} \end{aligned}$$

Here, if the value driven load resistance R_L is r , since the RFG pin voltage is 0.23 V and the npn transistor output saturation voltage is 0.1 V (typical), the pnp transistor output pin voltage can be calculated as follows.

$$\begin{aligned} V_{\text{out}} &= (\text{RFG pin voltage}) + (\text{npn transistor output saturation voltage}) + (\text{voltage across the load terminals}) \\ &= 0.23 + 0.1 + 0.209 \times r \\ &= 0.3 + 0.209r \end{aligned}$$

At the same time, however, this IC's internal constant voltage control circuit controls the output voltage as follows.

$$V_{\text{out}}' = V_C \times 1.95 \approx 1.75\text{ V}$$

Therefore, it will not be possible to use the constant current control mode if the value of r is set so that V_{out} is greater than V_{out}' . That is, the condition

$$0.33 + 0.209r > 1.75$$

implies that

$$r > 6.79$$

This means that constant current control can be used when the value of the load resistance used is strictly less than $6.79\ \Omega$.

- Specifications of any and all SANYO products described or contained herein stipulate the performance, characteristics, and functions of the described products in the independent state, and are not guarantees of the performance, characteristics, and functions of the described products as mounted in the customer's products or equipment. To verify symptoms and states that cannot be evaluated in an independent device, the customer should always evaluate and test devices mounted in the customer's products or equipment.
- SANYO Electric Co., Ltd. strives to supply high-quality high-reliability products. However, any and all semiconductor products fail with some probability. It is possible that these probabilistic failures could give rise to accidents or events that could endanger human lives, that could give rise to smoke or fire, or that could cause damage to other property. When designing equipment, adopt safety measures so that these kinds of accidents or events cannot occur. Such measures include but are not limited to protective circuits and error prevention circuits for safe design, redundant design, and structural design.
- In the event that any or all SANYO products (including technical data, services) described or contained herein are controlled under any of applicable local export control laws and regulations, such products must not be exported without obtaining the export license from the authorities concerned in accordance with the above law.
- No part of this publication may be reproduced or transmitted in any form or by any means, electronic or mechanical, including photocopying and recording, or any information storage or retrieval system, or otherwise, without the prior written permission of SANYO Electric Co., Ltd.
- Any and all information described or contained herein are subject to change without notice due to product/technology improvement, etc. When designing equipment, refer to the "Delivery Specification" for the SANYO product that you intend to use.
- Information (including circuit diagrams and circuit parameters) herein is for example only; it is not guaranteed for volume production. SANYO believes information herein is accurate and reliable, but no guarantees are made or implied regarding its use or any infringements of intellectual property rights or other rights of third parties.

This catalog provides information as of February, 2004. Specifications and information herein are subject to change without notice.