

Dual Output 150/300-mA Low Dropout Regulator

DESCRIPTION

SiP2211 is a dual output low dropout regulator capable of supplying 150 mA from output 1 and 300 mA from output 2. The SiP2211 has the outputs independently enabled. Also the SiP2211 offers a low dropout, low ground current and extremely low noise with the addition of a bypass capacitor.

Protection features include undervoltage lockout, output current limit, and thermal shutdown.

The Fixed output version of SiP2211 is available in a lead (Pb)-free MLP33-10 PowerPAK package and the adjustable version is available in a lead (Pb)-free MLP44-16 PowerPak package. Both packages are specified to operate over the range of - 40 °C to 85 °C.

FEATURES

- 2.25 V to 5.5 V Input Voltage Range
- Two Outputs - 150 mA and 300 mA
- Low Ground Current of 48 μ A
- Low Dropout Voltage of 65 mV at 100 mA
- Current Limit
- Thermal Shutdown
- MLP33-10 PowerPAK® Package (Fixed Output)
- MIC2211 Pin for Pin Replacement



RoHS
COMPLIANT

APPLICATIONS

- Cellular Phones
- Wireless Modems
- PDAs

TYPICAL APPLICATION CIRCUIT

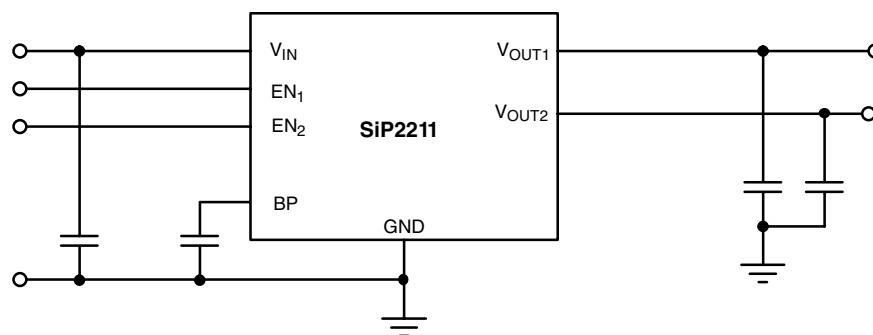



ABSOLUTE MAXIMUM RATINGS		
Parameter	Limit	Unit
V_{IN} , V_{EN} to GND	- 0.3 to 7	V
Power Dissipation	MLP33-10 PowerPAK ^b	1600
	MLP44-16 PowerPAK ^c	1880
Storage Temperature	- 55 to 150	°C
Thermal Resistance (MLP10 PowerPAK)	50	°C/W

Notes:

- a. Device Mounted with all leads soldered or welded to PC board.
 b. Derate 20 mW/°C above 70 °C.
 c. Derate 23.5 mW/°C above 70 °C.

Stresses beyond those listed under "Absolute Maximum Ratings" may cause permanent damage to the device. These are stress ratings only, and functional operation of the device at these or any other conditions beyond those indicated in the operational sections of the specifications is not implied. Exposure to absolute maximum rating conditions for extended periods may affect device reliability.

RECOMMENDED OPERATING RANGE		
Parameter	Limit	Unit
Input Voltage Range	2.25 to 5.5	V
Enable Voltage Range	0 to 5.5	
Operating Temperature Range T_A	- 40 to 85	°C
Operating Temperature Range T_J	- 40 to 125	

SPECIFICATIONS							
Parameter	Symbol	Test Conditions Unless Specified $V_{IN} = V_{OUT} + 1 V^e$, $C_{OUT} = 1 \mu F$, $I_{OUT} = 100 \mu A$, $T_A = 25 \text{ }^\circ\text{C}$	Temp ^a	Limits			Unit
				Min ^b	Typ ^c	Max ^b	
Regulators							
Output Voltage Accuracy		From Nominal V_{OUT}	Room	- 1		1	%
			Full	- 2		2	
Output Voltage Temperature Coefficient			Room		40		ppm/°C
Line Regulation ^e		$V_{IN} = V_{OUT} + 1 V$ to 5.5 V	Room	- 0.3	0.2	0.3	%
			Full	- 0.6		0.6	
Load Regulation		$I_{OUT} = 100 \mu A$ to 150 mA (LDO 1 and 2)	Room		0.2	1.0	%
		$I_{OUT} = 100 \mu A$ to 300 mA (LDO 2)	Room			1.5	
Dropout Voltage ^f	V_{DROPP}	$I_{OUT} = 150 \text{ mA}$ (LDO 1 and 2)	Room			120	mV
			Full			250	
		$I_{OUT} = 300 \text{ mA}$ (LDO 2)	Room		240	340	
			Full			420	
Ground Pin Current	I_G	$I_{OUT1} = I_{OUT2} = 0 \mu A$	Room		48	65	μA
		$I_{OUT1} = I_{OUT2} = 0 \mu A$	Full			80	
		$I_{OUT1} = 150 \text{ mA}$, $I_{OUT2} = 300 \text{ mA}$	Room		60		
		$V_{EN} < 0.4 \text{ V}$	Full			2.0	
Sequence Time Delay ^d	t_{SEQ}		Room		70		μs
Output Voltage Noise		$C_{BP} = 0.01 \mu F$				30	μV_{rms}
Ripple Rejection		$f = 1 \text{ kHz}$, $C_{OUT} = 1 \mu F$, $C_{BP} = 10 \text{ nF}$	Room		60		dB
		$f = 20 \text{ kHz}$, $C_{OUT} = 1 \mu F$, $C_{BP} = 10 \text{ nF}$	Room		40		
Inputs							
EN Input Voltage	V_{IL}	Logic Low	Full			0.6	V
	V_{IH}	Logic High	Full	1.8			
EN Input Current	I_{IL}	$V_{IL} < 0.6 \text{ V}$	Room	- 1	0.01	1	μA
	I_{IH}	$V_{IH} > 1.8 \text{ V}$	Room	- 1	0.01	1	

SPECIFICATIONS							
Parameter	Symbol	Test Conditions Unless Specified $V_{IN} = V_{OUT} + 1\text{ V}^e$, $C_{OUT} = 1\ \mu\text{F}$, $I_{OUT} = 100\ \mu\text{A}$, $T_A = 25\ ^\circ\text{C}$	Temp ^a	Limits			Unit
				Min ^b	Typ ^c	Max ^b	
Protection							
Current Limit	I_{IL}	$V_{OUT1} = 0\ \text{V}$	Room	150	280	460	mA
		$V_{OUT1} = 0\ \text{V}$	Room	300	450	700	
Thermal Shutdown Temperature			Room		165		$^\circ\text{C}$
Thermal Hysteresis			Room		25		

Notes:

a. Room = 25 °C, Full = - 40 to 85 °C.

b. The algebraic convention whereby the most negative value is a minimum and the most positive a maximum.

c. Typical values are for DESIGN AID ONLY, not guaranteed nor subject to production testing.

d. Timing is measured from 90 % of LDO #1's final value to 90 % of LDO #2's final value.

e. For higher output of the regulator pair.

f. Dropout voltage is defined as the input to output differential voltage at which the output voltage drops 2 % below the output voltage measured with a 1 V differential, provided that V_{IN} does not drop below 2.25 V. When $V_{OUT(nom)}$ is less than 2.25 V, the output will be in regulation when $2.25\ \text{V} - V_{OUT(nom)}$ is greater than the dropout voltage specified.

FUNCTIONAL BLOCK DIAGRAM

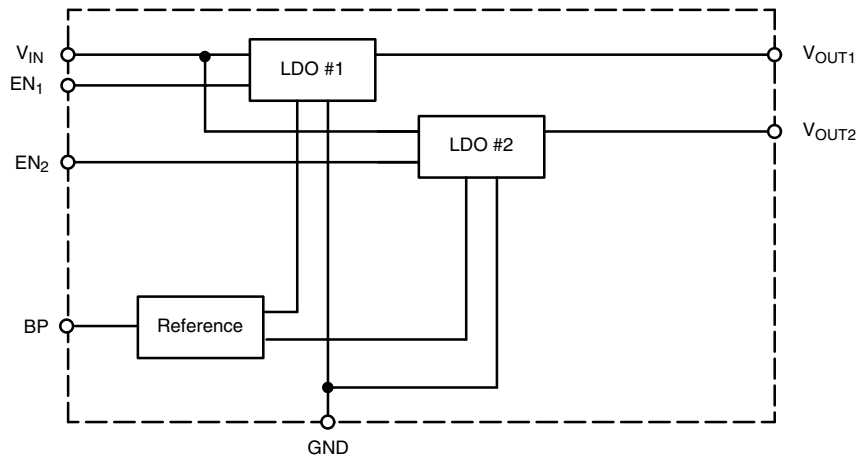

Fixed Voltage Version

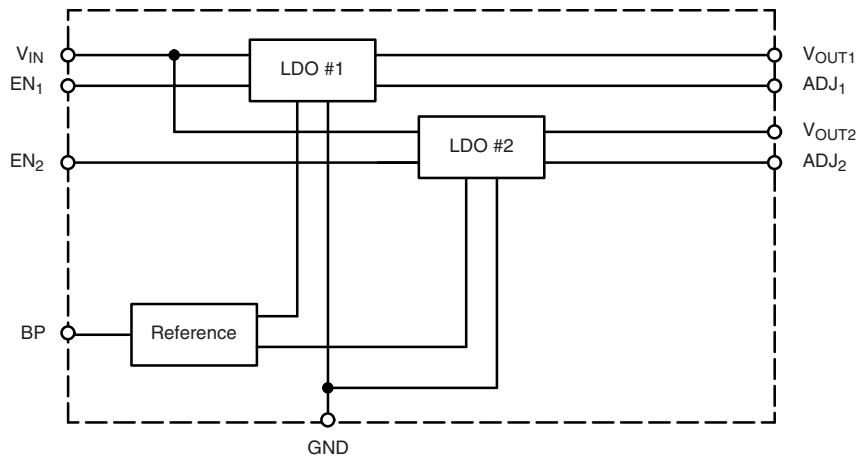

Adjustable Voltage Version

SiP2211

Vishay Siliconix



PIN CONFIGURATION AND ORDERING INFORMATION

PowerPAK MLP33-10 with Large Pad

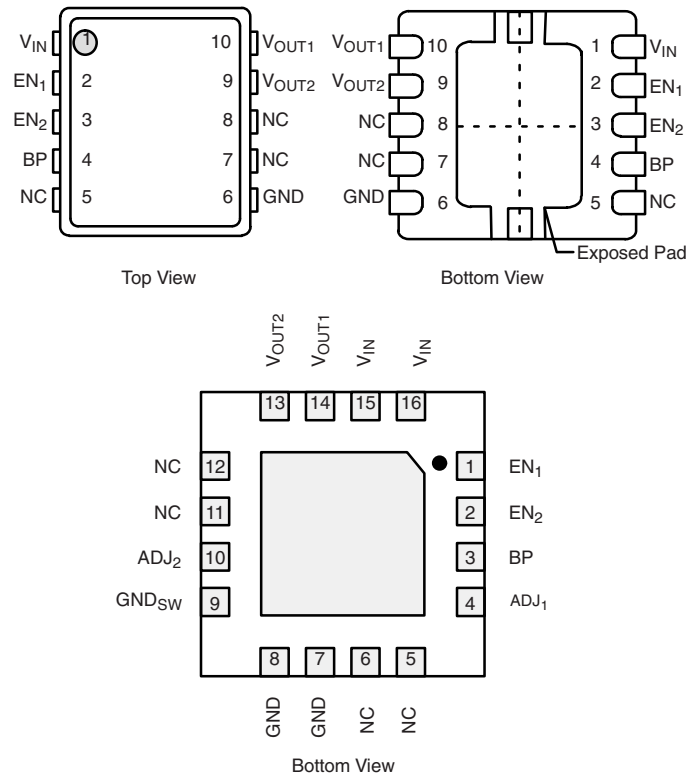

VOLTAGE OPTIONS	
Voltage	Code (x, Z)
Adj	A
1.5	F
1.6	W
1.8	G
1.85	D
1.9	Y
2.0	H
2.1	E
2.5	J
2.6	K
2.7	L
2.8	M
2.85	N
2.9	O
3.0	P
3.1	Q
3.2	R
3.3	S
3.4	T
3.5	U
3.6	V

ORDERING INFORMATION			
Part Number	Temp Range	Package	Marking
SiP2211DMP-XZ-E3	- 40 to 85 °C	PowerPAK MLP33-10	11XZ
SiP2211DLP-AA-E3		PowerPAK MLP44-16	11AA

X: Output 1 voltage code
Z: Output 2 voltage code

PIN DESCRIPTION			
Pin Number		Name	Function
MLP33-10	MLP44-16		
1	15, 16	V _{IN}	Input voltage for the power MOSFETs and their gate drive
2	1	EN ₁	Enables LDO #1 output
	6	NC	No Connection
3	2	EN ₂	Enables LDO #2 output
4	3	BP	Bypass for noise reduction
	4	ADJ ₁	Feedback connection for LDO #1
5	5	NC	No Connection
6	7, 8	GND	Ground
	9	GND _{SW}	Ground for the internal N-Channel MOSFET switch
	10	ADJ ₂	Feedback connection for LDO #2
7	11	NC	No Connection
8	12	NC	No Connection
9	13	V _{OUT2}	Output of LDO #2 - 300 mA
10	14	V _{OUT1}	Output of LDO #1 - 150 mA

The exposed pad on both packages must be connected externally to the GND pin.

TYPICAL CHARACTERISTICS

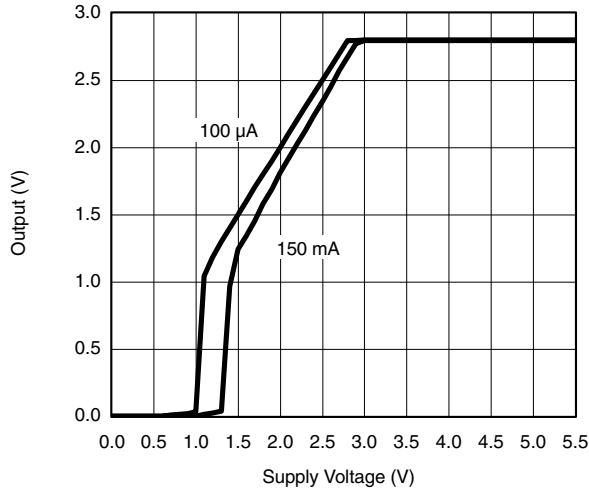

Dropout Characteristics-Output 1

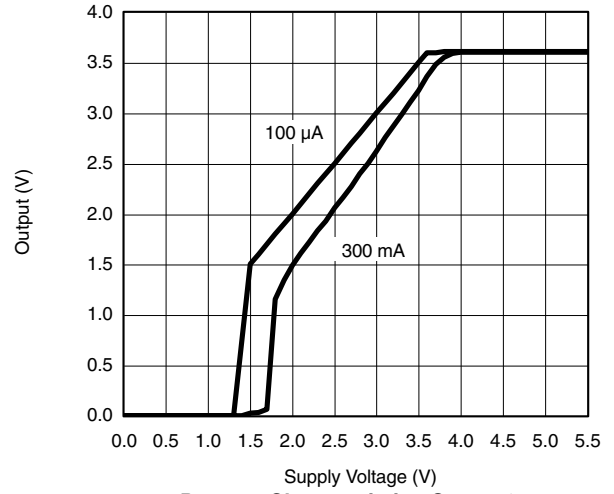

Dropout Characteristics-Output 2

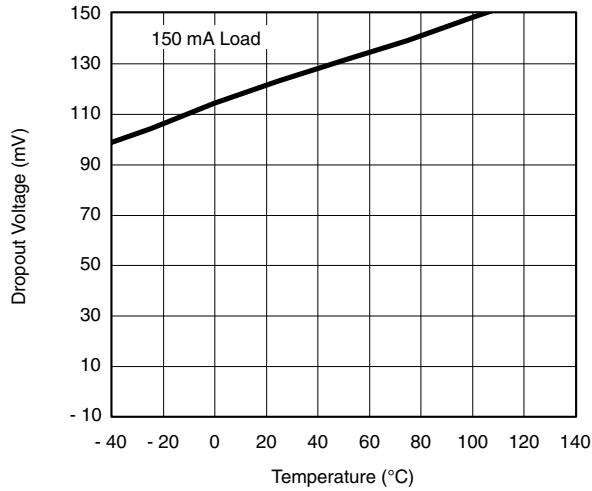

Dropout Voltage-Output 1

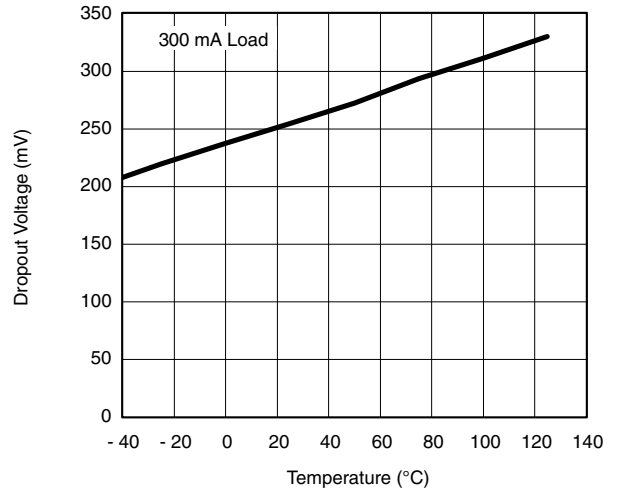

Dropout Voltage-Output 2

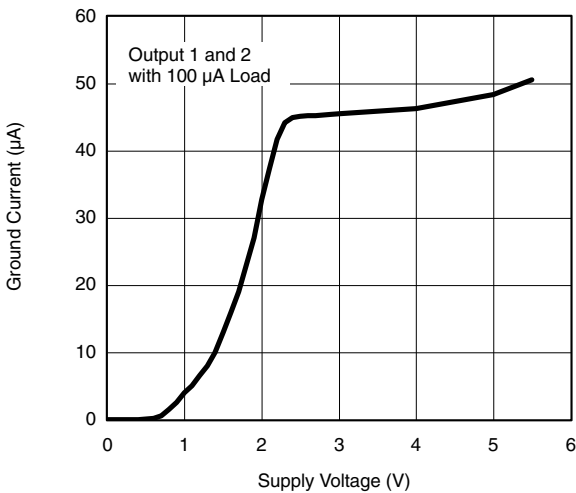

Ground Current vs. Supply Voltage

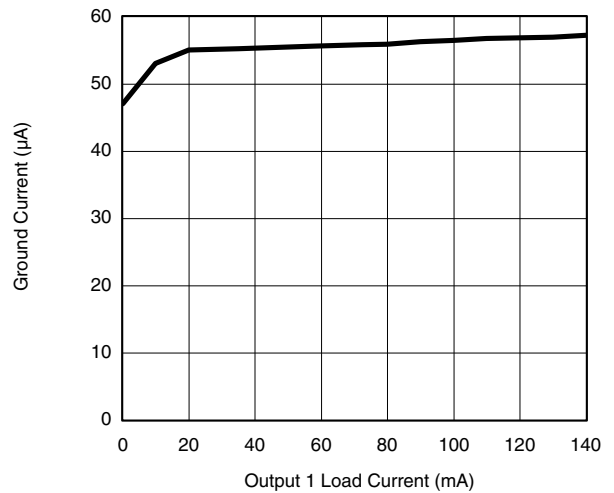

Ground Current vs. Output 1 Current



TYPICAL CHARACTERISTICS

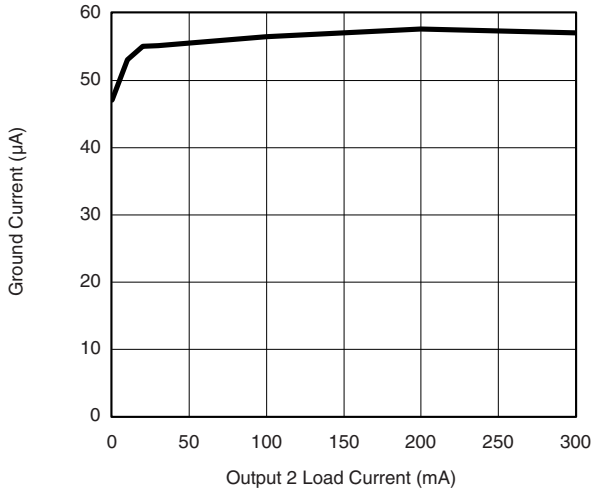

Ground Current vs. Output 2 Current

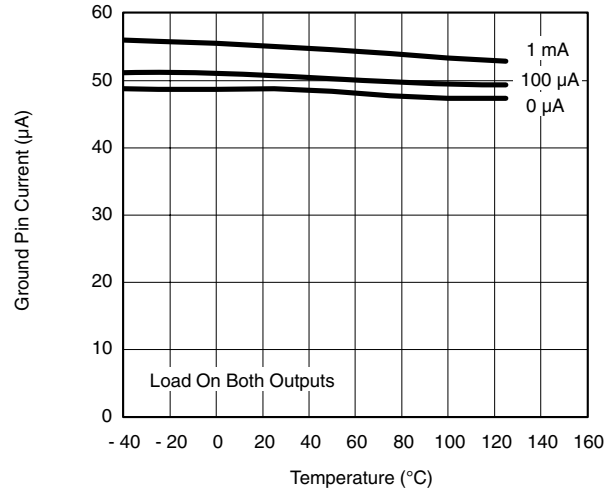

Ground Pin Current

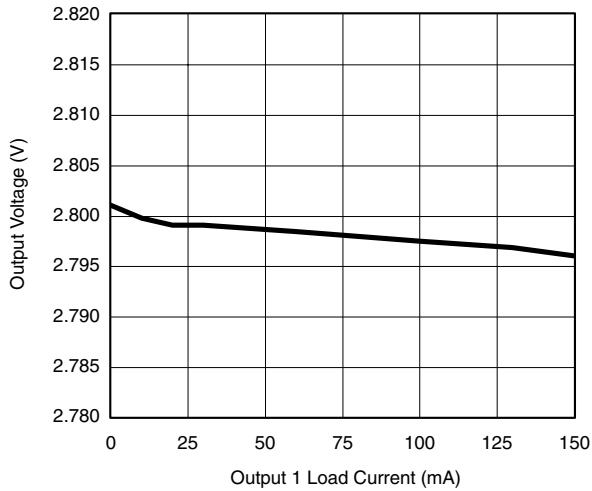

Output Voltage vs. Load Current-Output 1

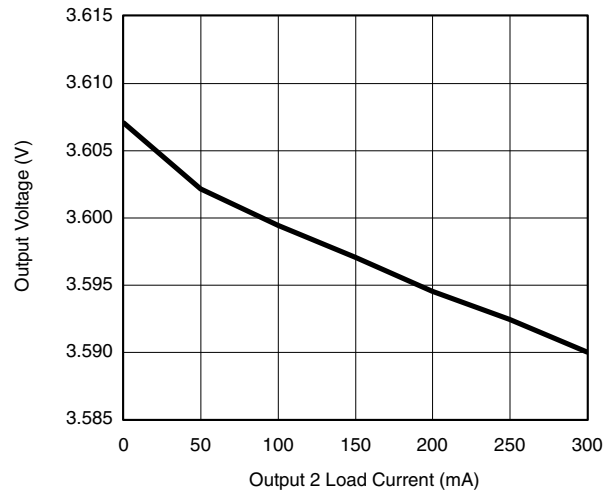

Output Voltage vs. Load Current-Output 2

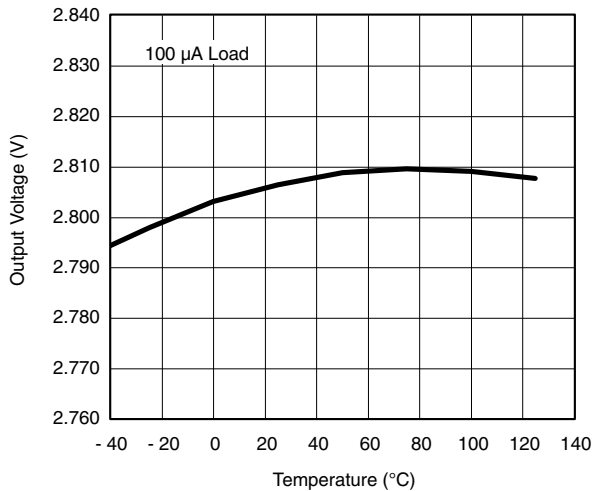

Output Voltage 1 vs. Temperature

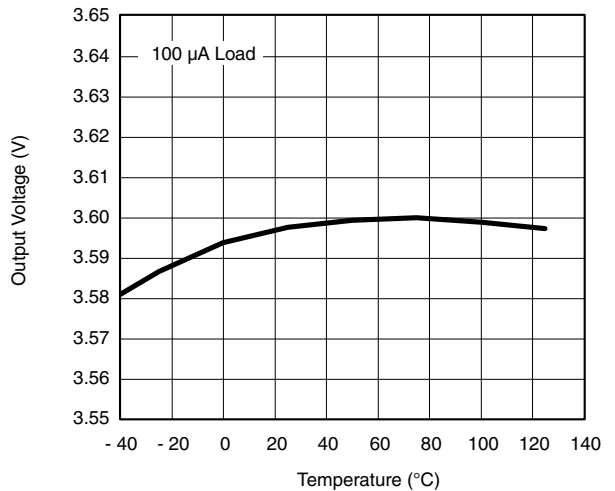

Output Voltage 2 vs. Temperature

TYPICAL CHARACTERISTICS

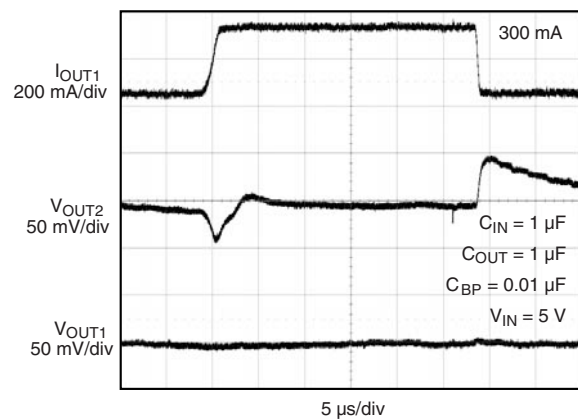
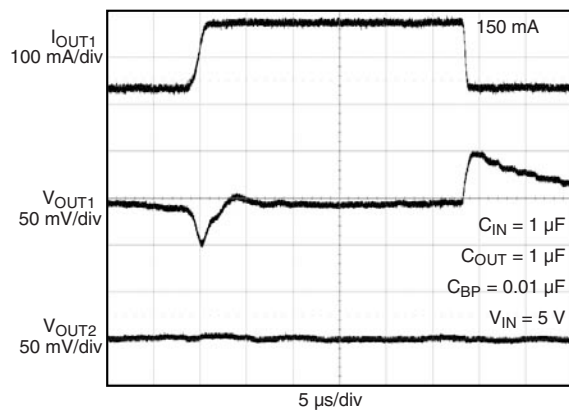
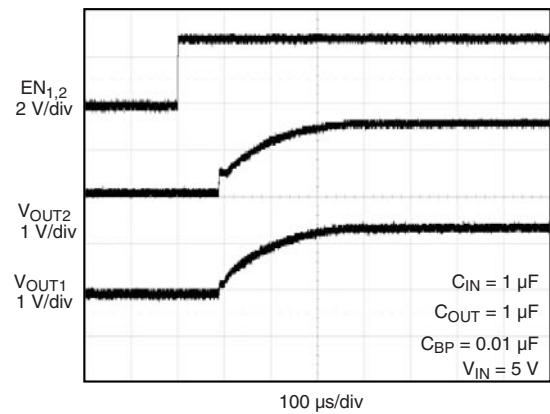
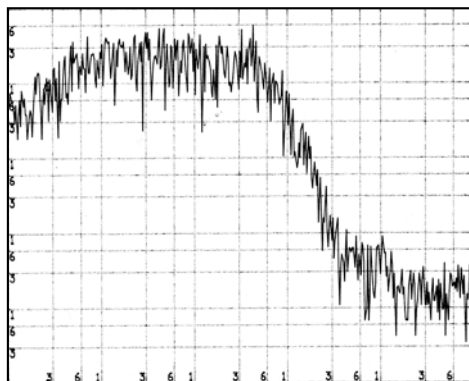
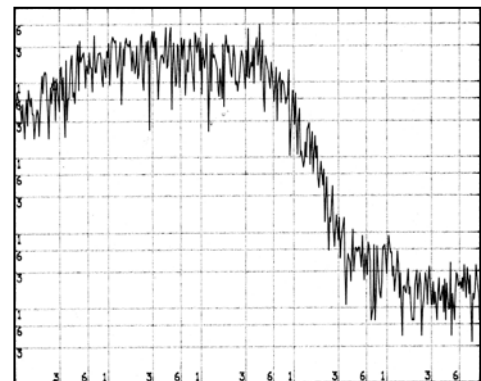
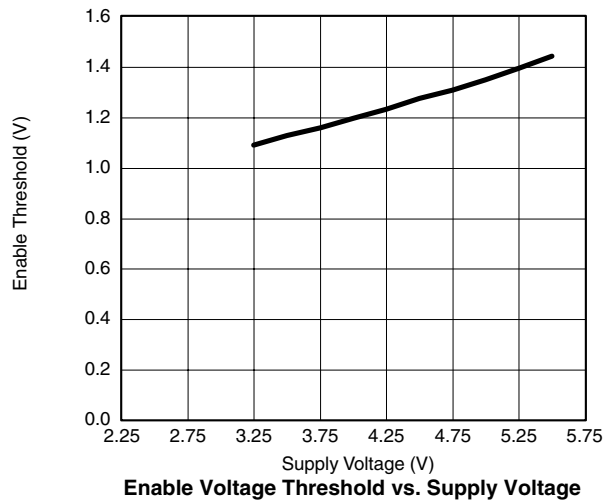



DETAILED OPERATION

The SiP2211 is a low drop out, low quiescent current monolithic dual linear regulator, with power-on reset and open drain driver output features. With output voltage range from 1.25 V to 5 V the first regulator can source 150 mA and the second regulator can source 300 mA. The open drain driver has the capability to drive LED's for backlighting applications.

V_{IN}

V_{IN} is the input supply pin for both LDO's. The bypass capacitor for this pin is not critical as long as the input supply has low enough source impedance. For practical circuits, a 1.0 μ F or larger ceramic capacitor is recommended. When the source impedance is not low enough and/or the source is several inches from the SiP2211, then a larger input bypass capacitor is needed. When the source impedance, wire and trace impedance are unknown, it is recommended that an input bypass capacitor be used of a value that is equal to or greater than the output capacitor.

$V_{OUT1,2}$ (LDO Outputs)

The V_{OUT} is the output voltage of the regulator. Connect a bypass capacitor from V_{OUTx} to ground. The output capacitor can be any value from 1.0 μ F to 10.0 μ F. A ceramic capacitor with X5R or X7R dielectric type is recommended for best output noise, line transient, and load transient performance.

Enable

The EN1 and EN2 pins control the turning on and off of their respective regulators in the SiP2211. V_{OUT} of both outputs are guaranteed to be on when the Enable pin voltage is equal or greater than 1.8 V. V_{OUT} is guaranteed to be off when the Enable pin voltage equals or is less than 0.6 V. To automatically turn on V_{OUT} whenever the Input is applied, tie the Enable pin to V_{IN} .

Bypass Capacitor

For low noise application and/or increase in power supply rejection ration (PSRR) connect a high frequency ceramic capacitor from BP to ground. A 0.01 μ F X5R or X7R ceramic capacitor is recommended.



Notice

Specifications of the products displayed herein are subject to change without notice. Vishay Intertechnology, Inc., or anyone on its behalf, assumes no responsibility or liability for any errors or inaccuracies.

Information contained herein is intended to provide a product description only. No license, express or implied, by estoppel or otherwise, to any intellectual property rights is granted by this document. Except as provided in Vishay's terms and conditions of sale for such products, Vishay assumes no liability whatsoever, and disclaims any express or implied warranty, relating to sale and/or use of Vishay products including liability or warranties relating to fitness for a particular purpose, merchantability, or infringement of any patent, copyright, or other intellectual property right.

The products shown herein are not designed for use in medical, life-saving, or life-sustaining applications. Customers using or selling these products for use in such applications do so at their own risk and agree to fully indemnify Vishay for any damages resulting from such improper use or sale.