

Li-Ion Battery Protector

General Description

The RT9541 Series are protection ICs for over-charge/discharge of rechargeable one-cell Lithium-ion (Li+) batteries by CMOS process.

The RT9541 Series can detect over-charge/discharge of Li+ one-cell and excess load current and charge current, further include a short circuit protector for preventing large external short circuit current.

Each of these ICs is composed of four voltage detectors, a reference unit, a hysteresis circuit, and a bidirectional short circuit protector. Package of SOT-26 is available.

Ordering Information

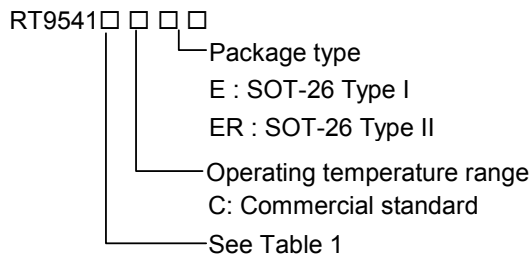

Typical Application Circuit

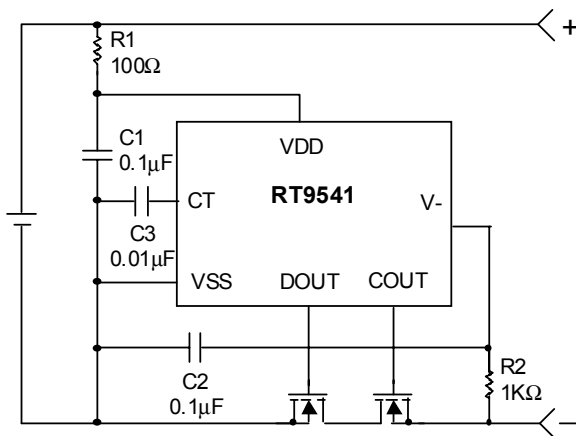

Features

- **Low supply current**
 - Supply current: TYP. 2.0μA
 - Standby current (after detecting over-discharge): Less than 0.2μA
- **High accuracy detector threshold**
 - Over-charge detector: ±25mV
 - Over-discharge detector: ±2.5%
- **Built-in protection circuit**
 - Excess current trip/Short circuit protector in both charging and discharging direction
- **Output delay of over-charge adjustable with an external capacitor: 75mS at 0.01μF**
- **Ultra small package: SOT26**

Applications

- Over-charge / Over-discharge Protection for Li+ One-cell Pack
- High Precision Protectors for Cellular Phones or Instruments Using Li+ One-cell Battery

Pin Configurations

| Part Number | Pin Configurations |
|--------------------------------|--|
| RT9541□CE (Plastic SOT-26) | <p>TOP VIEW</p> <p>1. COUT 2. CT 3. VSS 4. DOUT 5. VDD 6. V-</p> |
| RT9541□CER (Plastic SOT-26) | <p>TOP VIEW</p> <p>1. DOUT 2. V- 3. COUT 4. CT 5. VDD 6. VSS</p> |

Absolute Maximum Ratings

- Allowable Battery Voltage -0.3V ~ 7V
- Input Voltage (V) VDD-14V to VDD +0.3V
- Input Voltage (CT) VSS-0.3V to VDD +0.3V
- Output Voltage (COUT) VDD-14V to VDD +0.3V
- Output Voltage (DOUT) VSS-0.3V to VDD +0.3V
- Power Dissipation, P_D @ $T_A = 25^\circ\text{C}$
SOT-26 0.25W
- Package Thermal Resistance
SOT-26, θ_{JA} 250°C/W
- Operating Temperature Range $-20^\circ\text{C} \sim +85^\circ\text{C}$
- Storage Temperature Range $-65^\circ\text{C} \sim +150^\circ\text{C}$

Electrical Characteristics

| Parameter | Symbol | Test Conditions | Min | Typ | Max | Units |
|---|----------------------|---|---------|---------|---------|------------|
| Operating Input Voltage | V _{DD} | Voltage defined as VDD-VSS | 1 | -- | 6 | V |
| Charger Voltage | V _{CHG} | Voltage defined as VDD-V- | -- | -- | 14 | V |
| Minimum Operating Voltage for 0V Charging | | Voltage defined as VDD-V- VDD-VSS = 0V | -- | -- | 1 | V |
| Accuracy of Over-charge Threshold Voltage | ΔV_{OCHG} | Detect rising edge of supply voltage | -25 | -- | 25 | mV |
| Over-charge Threshold Hysteresis | | | 0.1 | 0.15 | 0.2 | V |
| Output Delay Time of Over-charge | T _{OCHG} | C3 = 0.01 μ F, VDD = 3.6V ~ 4.3V | 30 | 60 | 80 | mS |
| Accuracy of Over-discharge Threshold Voltage | $\Delta V_{ODISCHG}$ | Detect falling edge of supply voltage | -2.5 | -- | 2.5 | % |
| Output Delay Time of Over-discharge | T _{ODISCHG} | VDD = 3.6V ~ 2.4V | 10 | 15 | 20 | mS |
| Excess Current Threshold Voltage During Discharge | | Detect rising edge of "V-" pin voltage | 0.15 | 0.17 | 0.19 | V |
| Output Delay of Discharge Excess Current | | VDD = 3.0V | 15 | 20 | 25 | mS |
| Excess Current Threshold Voltage During Charge | | Detect falling edge of "V-" pin voltage | -0.19 | -0.17 | -0.15 | V |
| Output Delay of Charge Excess Current | | | 15 | 20 | 25 | mS |
| Short Detection Voltage During Discharge | | VDD = 3.0V | VDD-1.1 | VDD-0.8 | VDD-0.5 | V |
| Output Delay of Discharge Short Circuit | T _{SHORT} | VDD = 3.0V | -- | 5 | 50 | μ S |
| Reset Resistance for Excess Current Protection | R _{SHORT} | VDD = 3.6V, V- = 1.0V | 25 | 50 | 75 | k Ω |
| Supply Current | I _{DD} | VDD = 3.9V, V- = 0V | -- | 2.0 | 5.0 | μ A |
| Standby Current | I _{STANDBY} | VDD = 2.0V | -- | 0.1 | 0.5 | μ A |

Table 1

| Part Number | Over Charge | Over Discharge | Excess Current |
|---------------|-------------|----------------|----------------|
| RT9541ACE (R) | 4.25V | 2.3V | 170mV |
| RT9541BCE (R) | 4.25V | 2.4V | 170mV |
| RT9541CCE (R) | 4.25V | 2.5V | 170mV |
| RT9541DCE (R) | 4.25V | 2.6V | 170mV |
| RT9541ECE (R) | 4.25V | 2.7V | 170mV |
| RT9541FCE (R) | 4.25V | 2.8V | 170mV |
| RT9541GCE (R) | 4.30V | 2.3V | 170mV |
| RT9541HCE (R) | 4.30V | 2.4V | 170mV |
| RT9541ICE (R) | 4.30V | 2.5V | 170mV |
| RT9541JCE (R) | 4.30V | 2.6V | 170mV |

| Part Number | Over Charge | Over Discharge | Excess Current |
|---------------|-------------|----------------|----------------|
| RT9541KCE (R) | 4.30V | 2.7V | 170mV |
| RT9541LCE (R) | 4.30V | 2.8V | 170mV |
| RT9541MCE (R) | 4.35V | 2.3V | 170mV |
| RT9541NCE (R) | 4.35V | 2.4V | 170mV |
| RT9541OCE (R) | 4.35V | 2.5V | 170mV |
| RT9541PCE (R) | 4.35V | 2.6V | 170mV |
| RT9541QCE (R) | 4.35V | 2.7V | 170mV |
| RT9541RCE (R) | 4.35V | 2.8V | 170mV |
| RT9541SCE (R) | 4.35V | 2.9V | 170mV |
| RT9541TCE (R) | 4.25V | 2.9V | 170mV |

Function Block Diagram

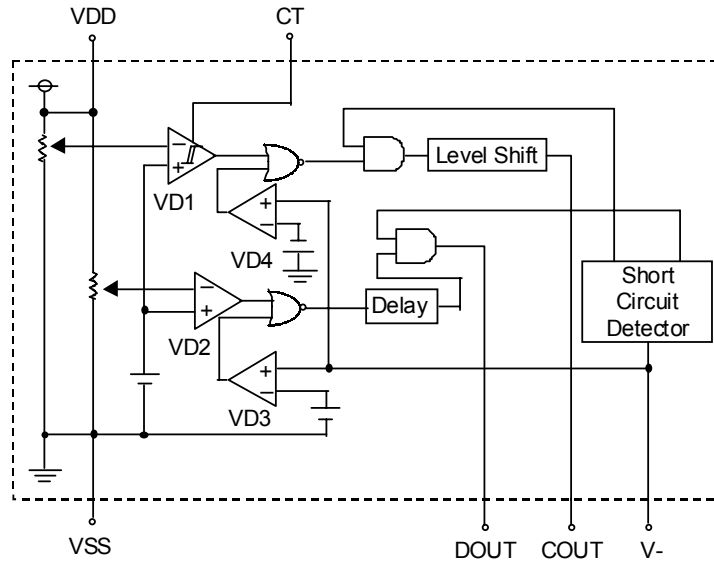

Pin Description

| Pin Number | | Pin Name | Pin Function |
|------------|-------------|----------|---|
| RT9541-□CE | RT9541-□CER | | |
| 1 | 3 | COUT | Output of Over-charge Detection, CMOS Output |
| 2 | 4 | CT | Pin for External Capacitor Setting Output Delay of VD1 |
| 3 | 6 | VSS | Ground |
| 4 | 1 | DOUT | Output of Over-discharge Detection, CMOS Output |
| 5 | 5 | VDD | Power Supply, through a Resistor (R1) |
| 6 | 2 | V- | Pin for Charger Negative Input, through a Resistor (R2) |

Applications Information

(1) Operation Description

Referring to the “Function Block Diagram”, when charging voltage crosses the detector threshold from a low value to a value higher than VDET1, the output of COUT pin, the output of over-charge detector/VD1, switches to low level, ..charger’s negative pin level. After detecting over-charge the VD1 can be reset and the output of COUT pin becomes “H” when the VDD voltage is coming down to a level lower than “VDET1 – VHYS1”, or when a charger is disconnected from the battery pack.

The output of DOUT pin, the output of over-discharge detector/VD2, switches to “L” after internally fixed delay time passed, when discharging voltage crosses the detector threshold from a high value to a value lower than VDET2. An excess load current can be sensed and cut off after internally fixed delay time passed through the built in excess current detector, VD3, with DOUT being enabled to low level. Once after detecting excess current, the VD3 is released and DOUT level switches to “H” by detaching a battery pack from a load system.

Further, short circuit protector makes DOUT level to “L” immediately with external short circuit current and removing external short circuit leads DOUT level to “H”.

The excess charging current is also monitored, and the charging path will be cut off (by turn low COUT) after excess charging current was detected lasting a internally fixed delay time. The charging path will be re-started (by turn high COUT) after another internally fixed delay. If the excess charging current is still there, the same process will be repeated and cause the charging path toggling on and off with a 12.5% on duty. Such a protection function reduces the average charging current to 12.5% of original value when excess charging current detected.

The short circuit protection function in charging direction was also provided. When COUT high and the “V-“ pin voltage 5V lower than VSS pin, the RT9541 will turn low COUT with a fixed delay. The COUT will go high after the short circuit condition was removed.

After detecting over-discharge, supply current will be kept extremely low by halting some internal circuits operation. The output delay of over-charge detectors can be set by connecting an external capacitor. Output type of COUT and DOUT are CMOS.

(2) Component Selection Guide:

Referring to “Typical Application Circuit”, R1 and C1 will stabilize a supply voltage to the RT9541. A recommended R1 value is less than $1k\Omega$. A larger value of R1 leads higher detection voltage, makes some errors, because of shoot through current flowed in the RT9541.

R2 and C2 will stabilize a V- pin voltage. The resetting from over-discharge with connecting charger possibly be disabled by larger value of R2. Recommended value is less than $1k\Omega$. And recommended C2 value is less than $1\mu F$.

R1 and R2 can operate as a current limiter against setting cell reverse direction or for applying excess charging voltage to the RT9541. While smaller R1 and R2 may cause an over power dissipation rating of the RT9541 and a total of “R1+R2” should be more than $1k\Omega$.

Timing Diagram

RT9541-□CE/CER

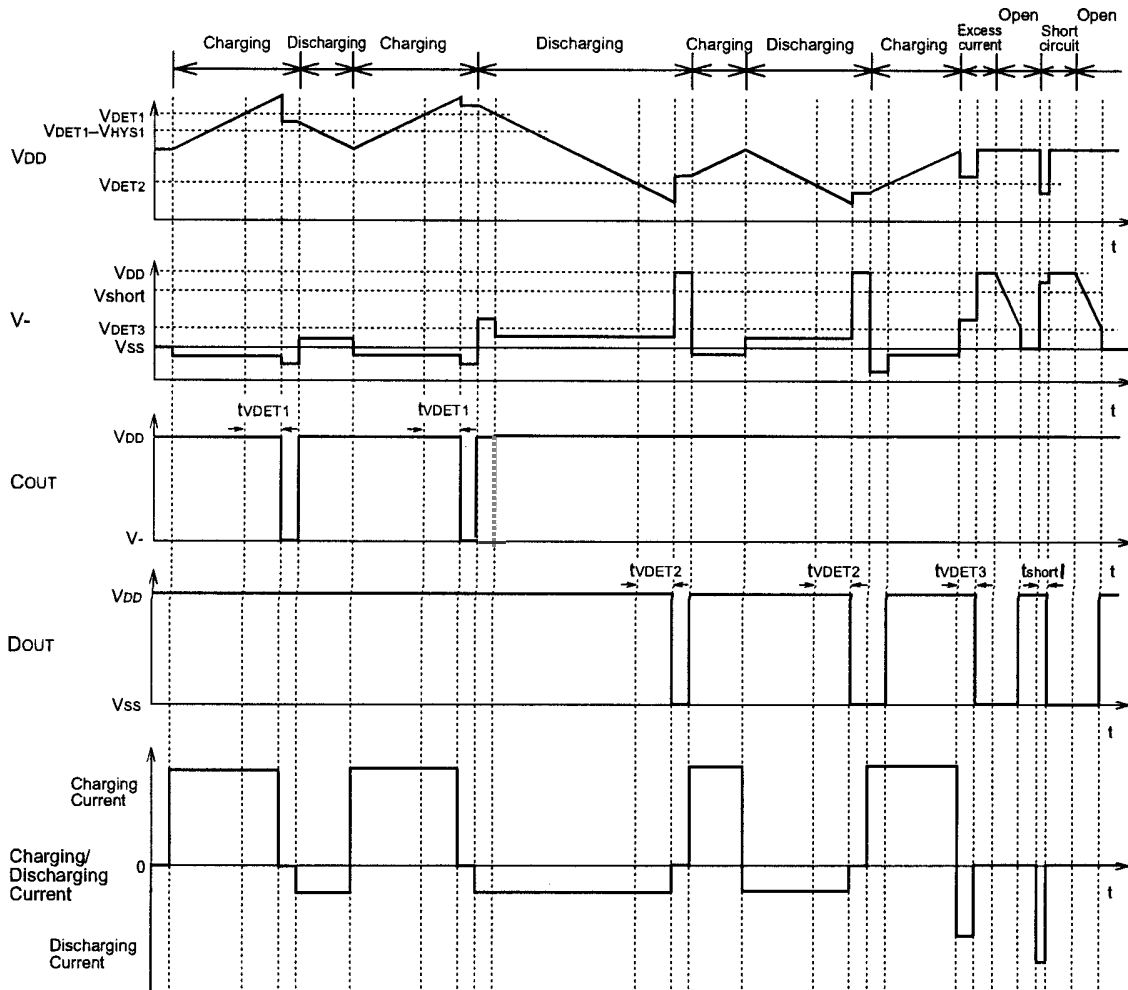

Package Information

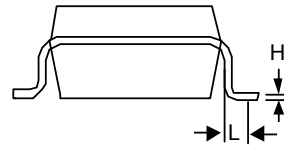
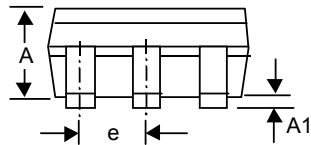
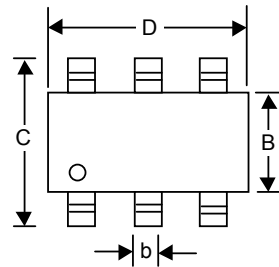

| Symbol | Dimensions In Millimeters | | Dimensions In Inches | |
|--------|---------------------------|-------|----------------------|-------|
| | Min | Max | Min | Max |
| A | 0.889 | 1.295 | 0.035 | 0.051 |
| A1 | -- | 0.152 | -- | 0.006 |
| B | 1.397 | 1.803 | 0.055 | 0.071 |
| b | 0.356 | 0.559 | 0.014 | 0.022 |
| C | 2.591 | 2.997 | 0.102 | 0.118 |
| D | 2.692 | 3.099 | 0.106 | 0.122 |
| e | 0.838 | 1.041 | 0.033 | 0.041 |
| H | 0.102 | 0.254 | 0.004 | 0.010 |
| L | 0.356 | 0.610 | 0.014 | 0.024 |

RICHTEK TECHNOLOGY CORP.

Headquarter

6F, No. 35, Hsintai Road, Chupei City

Hsinchu, Taiwan, R.O.C.

Tel: (8863)5510047 Fax: (8863)5537749

RICHTEK TECHNOLOGY CORP.

Taipei Office (Marketing)

8F-1, No. 137, Lane 235, Paochiao Road, Hsintien City

Taipei County, Taiwan, R.O.C.

Tel: (8862)89191466 Fax: (8862)89191465

Email: marketing@richtek-ic.com.tw