

SI-3000LUS Series

Surface-Mount, Low Current Consumption, Low Dropout Voltage Dropper Type

■Features

- Compact surface-mount package (SOT-89-3)
- Output current: 250 mA
- Low dropout voltage: $V_{DIF} \leq 0.5 \text{ V}$ (at $I_o = 250 \text{ mA}$)
- 4 types of output voltages (1.8 V, 2.5 V, 3.3 V, 5.0 V) available
- Built-in dropping type overcurrent, thermal protection circuits

■Applications

- Auxiliary power supply for PC
- Battery-driven electronic equipment

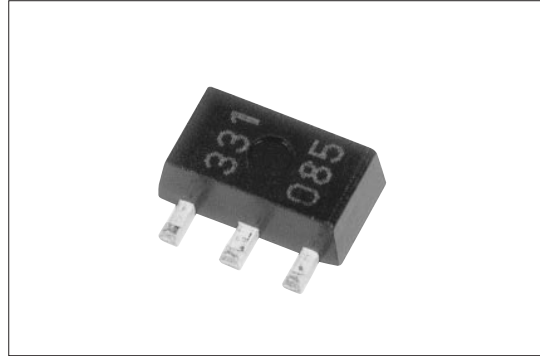

■Absolute Maximum Ratings

($T_a=25^\circ\text{C}$)

Parameter	Symbol	Ratings	Unit
DC Input Voltage	V_{IN}	18	V
DC Output Current	I_o	250	mA
Power Dissipation	P_D^{*1}	0.75	W
Junction Temperature	T_j^{*2}	-40 to +135	$^\circ\text{C}$
Storage Temperature	T_{op}^{*2}	-40 to +125	$^\circ\text{C}$
Thermal Resistance (Junction to Ambient Air)	θ_{j-a}^{*1}	146	$^\circ\text{C/W}$

*1: When mounted on glass-epoxy board $40 \times 40 \text{ mm}$ (copper laminate area 2%)

*2: Thermal protection circuits may operate if the junction temperature exceeds 135°C

■Recommended Operating Conditions

Parameter	Symbol	Ratings		Unit
		min.	max.	
Input Voltage	V_{IN}	*2	V_o+2^{*1}	V
DC Output Current	I_o	0	250	mA
Ambient Operating Temperature	T_{op}	-20	85	$^\circ\text{C}$

*1: $V_{IN}(\text{max})$ and $I_o(\text{max})$ are restricted by the relationship $P_D = (V_{IN} - V_o) \times I_o$.
Calculate these values referring to the reference data.

*2: Refer to the dropout voltage section.

■Electrical Characteristics

(Ta=25°C, Vc=2V unless otherwise specified)

Parameter	Symbol	Ratings												Unit
		SI-3018LUS (Under development)			SI-3025LUS (Under development)			SI-3033LUS			SI-3050LUS (Under development)			
		min.	typ.	max.	min.	typ.	max.	min.	typ.	max.	min.	typ.	max.	
Output Voltage	Vo	1.764	1.800	1.836	2.450	2.500	2.550	3.234	3.300	3.366	4.900	5.000	5.100	V
	Conditions	VIN=3.3V, Io=10mA			VIN=3.3V, Io=10mA			VIN=5V, Io=10mA			VIN=6V, Io=10mA			
Dropout Voltage	V _{DIF}			0.3			0.3			0.3			0.3	V
	Conditions	Io=100mA												
	Conditions			0.5			0.5			0.5			0.5	
Line Regulation	ΔV _{LINE}			10			10			10			10	mV
	Conditions	VIN=3.3 to 5V, Io=10mA			VIN=3.3 to 5V, Io=10mA			VIN=4.5 to 8V, Io=10mA			VIN=6 to 10V, Io=10mA			
Load Regulation	ΔV _{LOAD}			40			40			40			40	mV
	Conditions	VIN=3.3V, Io=0 to 250mA			VIN=3.3V, Io=0 to 250mA			VIN=5V, Io=0 to 250mA			VIN=6V, Io=0 to 250mA			
Temperature Coefficient of Output Voltage	ΔVo/ΔTa		±0.25			±0.25			±0.3			±0.3		mV/°C
	Conditions	Tj=0 to 100°C												
Ripple Rejection	R _{REJ}		55			55			55			55		dB
	Conditions	VIN=3.3V, f=100 to 120Hz			VIN=3.3V, f=100 to 120Hz			VIN=5V, f=100 to 120Hz			VIN=6V, f=100 to 120Hz			
Quiescent Circuit Current	I _q			250			250			250			250	μA
	Conditions	VIN=3.3V, Io=0mA			VIN=3.3V, Io=0mA			VIN=5V, Io=0mA			VIN=6V, Io=0mA			
Overcurrent Protection Starting Current*1	IS ₁	260			260			260			260			mA
	Conditions	VIN=3.3V			VIN=3.3V			VIN=5V			VIN=6V			

*1: IS₁ is specified as the 5% drop point of output voltage Vo on the condition that VIN=3.3 V (5 V for SI-3033LUS, 6 V for SI-3050LUS), and Io=10 mA.

■External Dimensions

(Unit : mm)

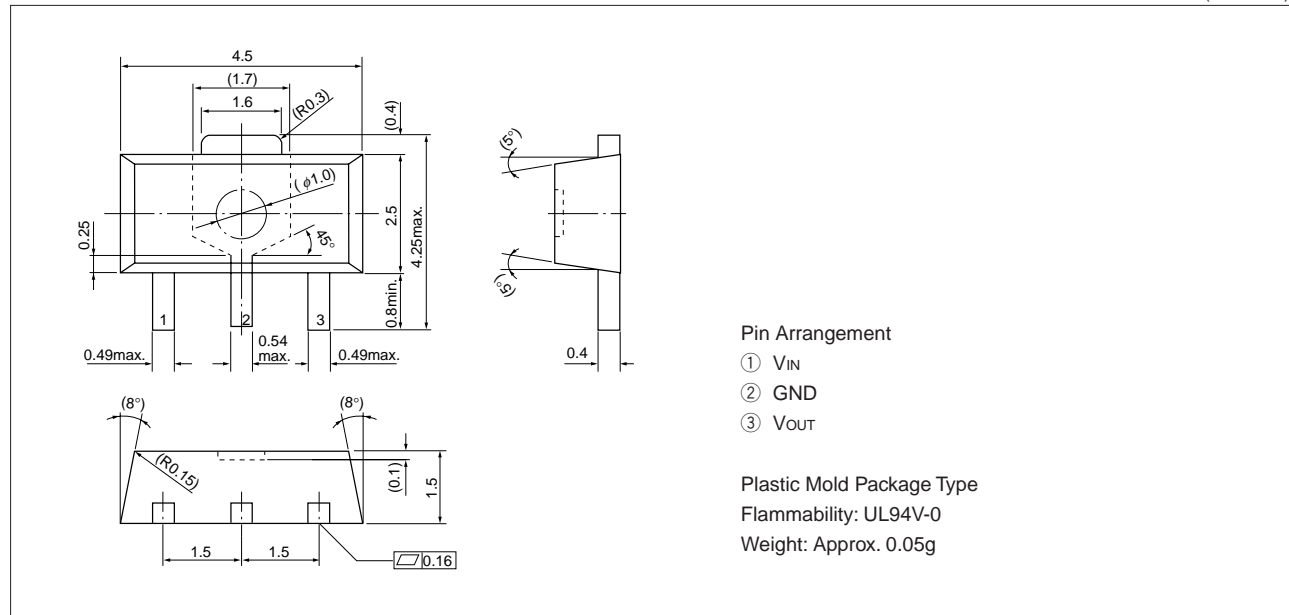

■Block Diagram

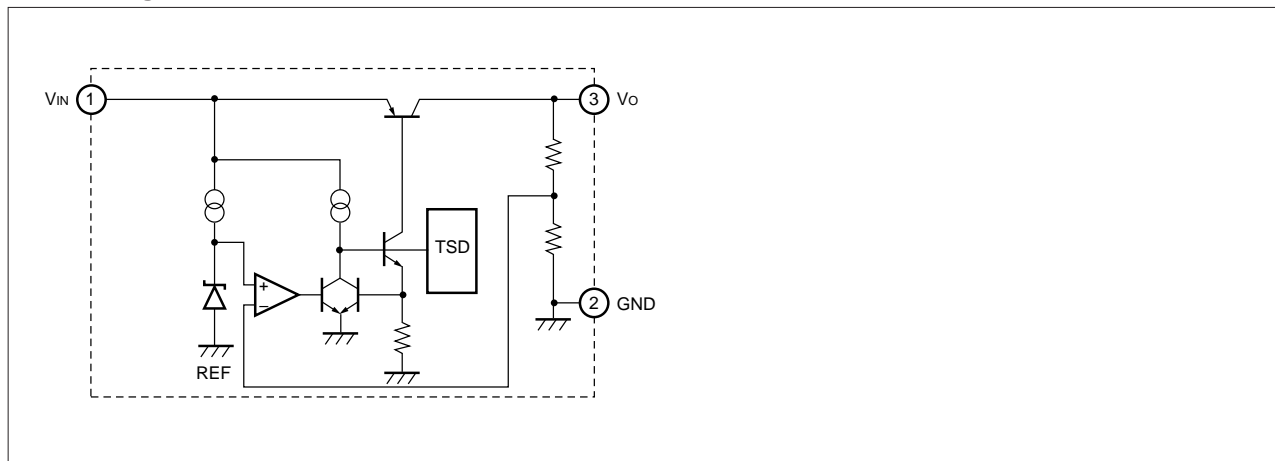

■Standard External Circuit

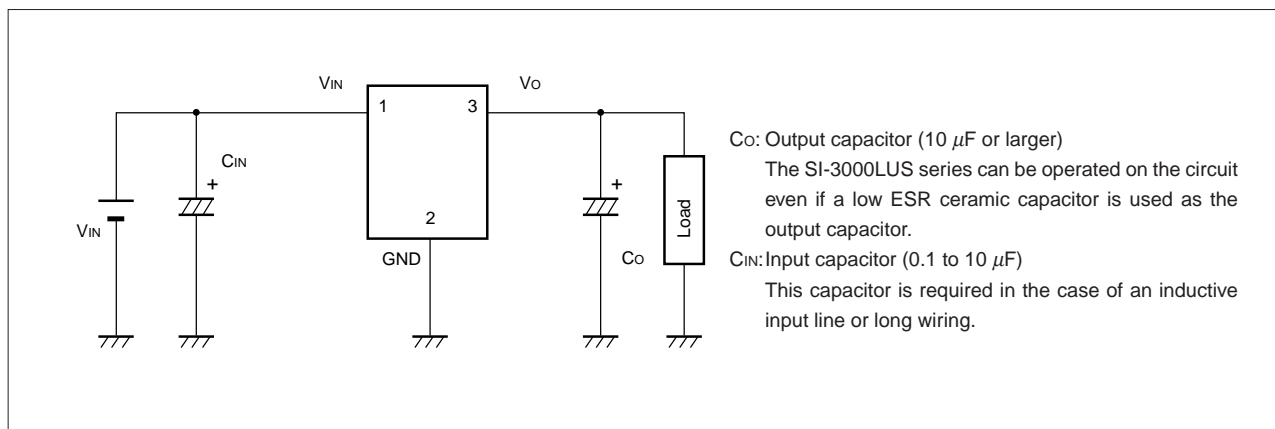

■Reference Data

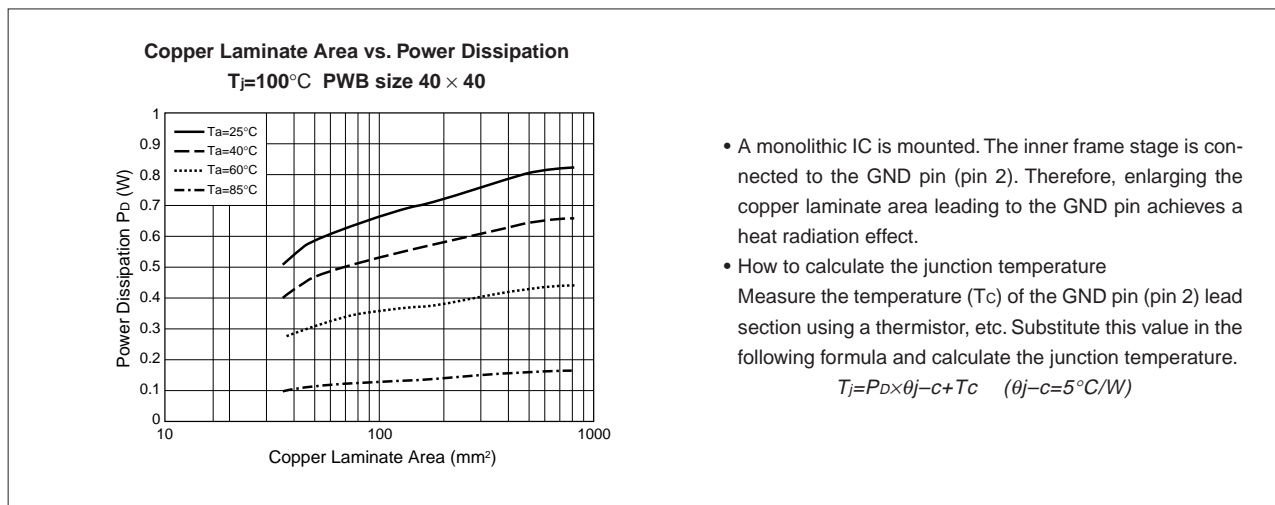

■Typical Characteristics of SI-3033LUS

($T_a=25^\circ\text{C}$)

I_o vs. V_{DIF} Characteristics

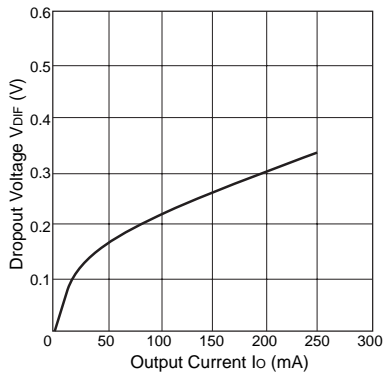

Output Voltage Characteristics

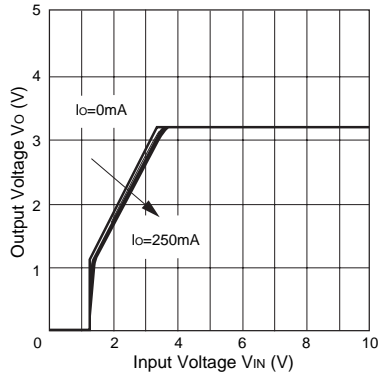

Line Regulation

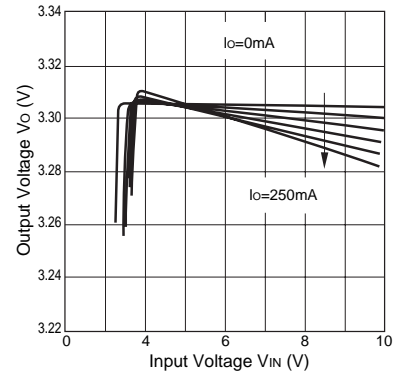

Load Regulation

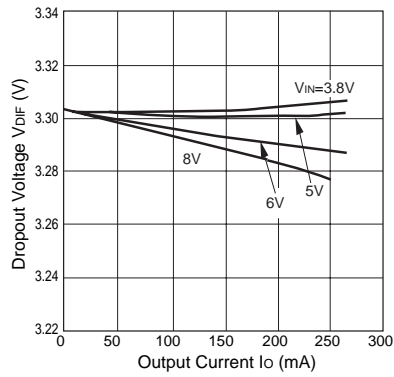

Overcurrent Protection Characteristics

