

MGA-13216

High Gain, High Linearity, Very Low Noise Amplifier



Data Sheet

Description

Avago Technologies' MGA-13216 is a two stage, easy-to-use GaAs MMIC Low Noise Amplifier (LNA). The LNA has low noise with good input return loss and high linearity achieved through the use of Avago Technologies' proprietary 0.25 μm GaAs Enhancement-mode pHEMT process. Minimum matching needed for input, output and the inter-stage between the two LNA.

It is designed for optimum use between 1.5 GHz to 2.5 GHz. For optimum performance at lower frequency from 400 MHz to 1.5 GHz, the MGA-13116 is recommended. Both MGA-13216 & MGA-13116 share the same package and pinout configuration.

Pin Configuration and Package Marking

4.0 x 4.0 x 0.85 mm³ 16-lead QFN

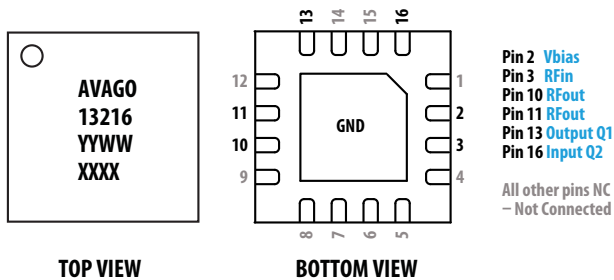

Note:

Package marking provides orientation and identification

"13216" = Device Part Number

"YYWW" = Work Week and Year of Manufacture

"XXXX" = Lot Number

Attention: Observe precautions for handling electrostatic sensitive devices.
ESD Machine Model = 90 V
ESD Human Body Model = 650 V
Refer to Avago Application Note A004R:
Electrostatic Discharge, Damage and Control.

Features

- Optimum frequency of operation 1.5 GHz – 2.5 GHz
- Very low noise figure
- High gain
- High linearity performance
- Excellent isolation
- GaAs E-pHEMT Technology^[1]
- Low cost small package size: 4.0 x 4.0 x 0.85 mm³

Specifications

1.95 GHz; Q1: 5 V, 53 mA (typ) Q2: 5 V, 122 mA (typ)

- 0.61 dB Noise Figure
- 35.8 dB Gain
- 46 dB Q1's Output pin to Q2's Input pin Isolation
- 40.5 dBm Output IP3
- 23.6 dBm Output Power at 1dB gain compression

Applications

- Low noise amplifier for cellular infrastructure including GSM, CDMA, and W-CDMA.
- Other very low noise applications.

Simplified Schematic

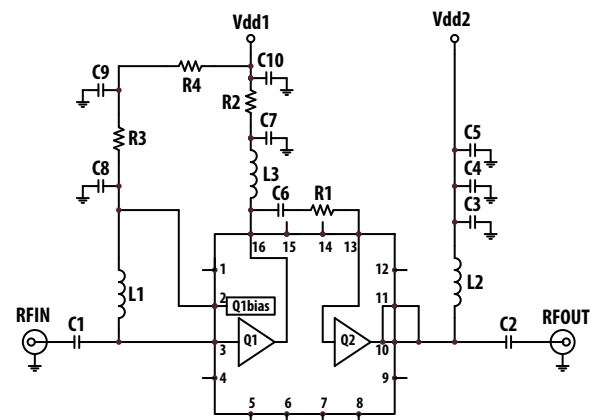

Notes: Enhancement mode technology employs positive gate bias, thereby eliminating the need of negative gate voltage associated with conventional depletion mode devices.

MGA-13216 Absolute Maximum Rating ^[1] TA = 25° C

Symbol	Parameter	Units	Absolute Maximum
Vdd1	Device Voltage	V	5.5
Vdd2	Device Voltage	V	5.5
Idd1	Q1 Drain Current	mA	90
Pd	Power Dissipation ⁽²⁾	W	1.11
P _{in,max}	CW RF Input Power	dBm	20
T _{j,max}	Junction Temperature	°C	150
T _{stg}	Storage Temperature	°C	-65 to 150

Thermal Resistance ^[3]

(V_{dd1} = 5.0V, I_{dd1} = 53mA, V_{dd2} = 5.0V, I_{dd2} = 122mA) $\theta_{jb} = 40.3^{\circ} \text{C/W}$

Notes:

1. Operation of this device in excess of any of these limits may cause permanent damage.
2. Board temperature (T_b) is 25°C. For T_b > 100°C, derate the device power at 24.8 mW per °C rise in board temperature adjacent to package bottom.
3. Thermal resistance measured using Infrared Measurement Technique.

Electrical Specifications ^[1]

RF performance at Vdd1 = 5 V, Vdd2 = 5 V, 1.95 GHz, T_A = 25° C, measured on the demo board for 1.95 GHz matching.

Symbol	Parameter and Test Condition	Units	Min.	Typ.	Max.
Idd1	Current at Q1	mA	39	53	67
Idd2	Current at Q2	mA	101	122	143
NF	Noise Figure	dB	–	0.61	0.9
Gain	Gain	dB	34.3	35.8	37.3
OIP3 ^[2]	Output Third Order Intercept Point	dBm	37	40.5	–
OP1dB	Output Power at 1 dB Gain Compression	dBm	22.3	23.6	–
IRL	Input Return Loss, 50 Ω source	dB	–	-18	–
ORL	Output Return Loss, 50 Ω load	dB	–	-10.7	–
S12	Reverse Isolation	dB	–	55	–
ISOL ₁₋₂	Isolation between Q1's Output pin & Q2's Input pin	dB	–	46	–

Notes:

1. Measurements obtained using demo board described in Figure 7 with component list in Table 1. Input and Output trace loss is not de-embedded from the measurement.
2. OIP3 test condition: f_{tone1} = 1.95 GHz, f_{tone2} = 1.951 GHz with input power of -27 dBm per tone.
3. Use proper bias, heatsink and derating to ensure maximum channel temperature is not exceeded. See absolute maximum ratings and application note for more details.

Product consistency Distribution Charts [1,2]

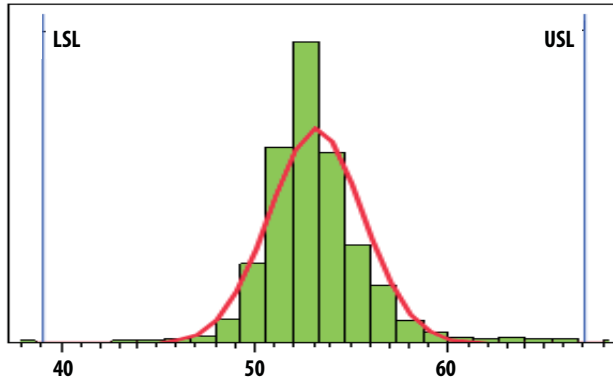

Figure 1. Idd1 @ 1.95 GHz, Vdd1 = 5 V, LSL = 39 mA, Nominal = 53 mA, USL = 67 mA

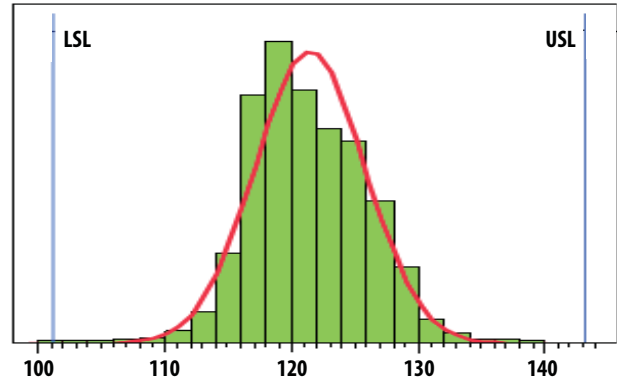

Figure 2. Idd2 @ 1.95 GHz, Vdd2 = 5 V, LSL = 101 mA, Nominal = 122 mA, USL = 143 mA

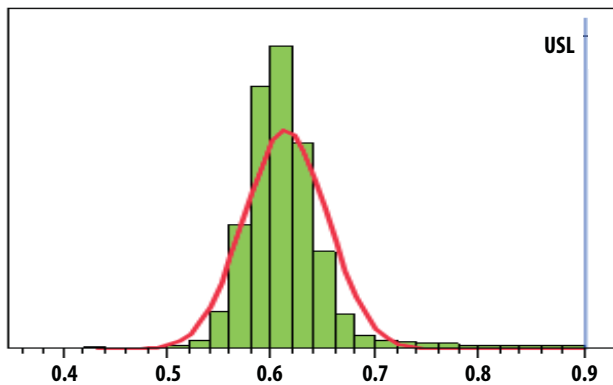

Figure 3. Noise Figure @ 1.95 GHz, Vdd1 = 5 V, Vdd2 = 5 V, Nominal = 0.61 dB, USL = 0.9 dB

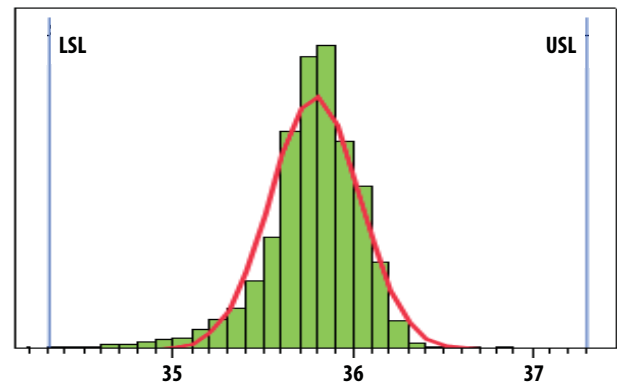

Figure 4. Gain @ 1.95 GHz, Vdd1 = 5 V, Vdd2 = 5 V, LSL = 34.3 dB, Nominal = 35.8 dB, USL = 37.3 dB

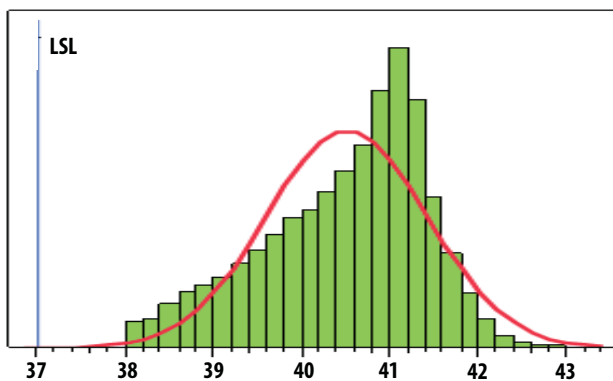

Figure 5. OIP3 @ 1.95 GHz, Vdd1 = 5 V, Vdd2 = 5 V, LSL = 37 dBm, Nominal = 40.5 dBm

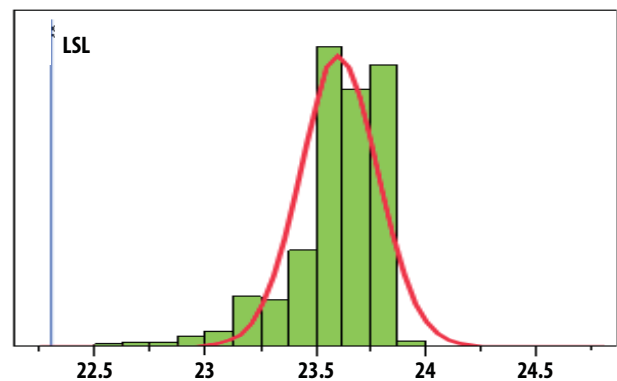

Figure 6. OP1dB @ 1.95 GHz, Vdd1 = 5 V, Vdd2 = 5 V, LSL = 22.3 dBm, Nominal = 23.6 dBm

Notes:

1. Data sample size is 9193 samples taken from 3 different wafers. Future wafers allocated to this product may have nominal values anywhere between the upper and lower limits.
2. Measurements are made on production test board which represents a trade-off between optimal Gain, NF, OIP3 and OP1dB. Circuit losses have been de-embedded from actual measurements.

Demo Board Layout

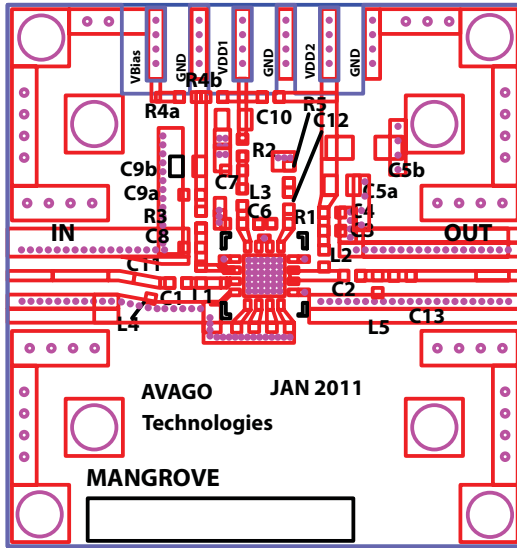

Figure 7. Demo Board layout diagram.

Demo Board Schematic

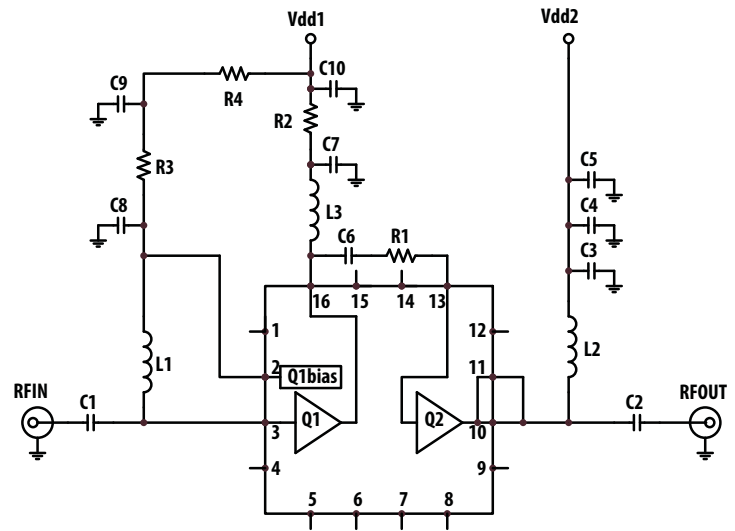

Figure 8. Demo Board schematic diagram.

- Recommended PCB material is 10 mils Rogers R04350.
- Suggested component values may vary according to layout and PCB material.

Table 1. Component list for 1.95 GHz matching

Part	Size	Value	Detail Part Number	Notes
C1	0402	10 pF (Murata)	GRM1555C1H100JZ01E	DC Blocking Capacitor
L1	0402	5.6 nH (Toko)	LL1005-FHL5N6S	Input match for NF
C9a, C10	0402	4.7 μ F (Murata)	GRM155R60E475ME760	Bypass Capacitors
R4b	0402	4.7 Kohm (Rohm)	MCR01J472	Biasing Resistor for Q1
R3	0402	49.9 ohm (Koa)	RK73H1ELTP49R9F	Stabilizing Resistor for Q1
R2, R1	0402	0 ohm (Koa)	RK73Z1ELTP	Bridging Resistors
L3	0402	100 nH (Toko)	LL1005-FHLR10J	Output match for Q1
C7, C8	0402	10 pF (Murata)	GRM1555C1H100JZ01E	Bypass Capacitors
C6	0402	1000 pF (Murata)	GRM155R71H102KA01E	DC Blocking Capacitor
C5a	0603	2.2 μ F (Murata)	GRM188R61A225KE34D	Bypass Capacitor
C4	0402	0.1 μ F (Murata)	GRM155R61A104KA01D	Bypass Capacitor
C3	0402	3.3 pF (Murata)	MCH155A3R3JK	Bypass Capacitor
L2	0402	4.7 nH (Toko)	LL1005-FH4N7S	Output match for Q2
C2	0402	100 pF (Murata)	GRM1555C1H101JD01E	DC Blocking Capacitor

MGA-13216 Typical Performance in Demoboard for 1.95 GHz

$T_A = 25^\circ\text{C}$, $V_{dd1} = 5.0\text{V}$, $V_{dd2} = 5.0\text{V}$, $I_{dd1} = 53\text{mA}$, $I_{dd2} = 122\text{mA}$

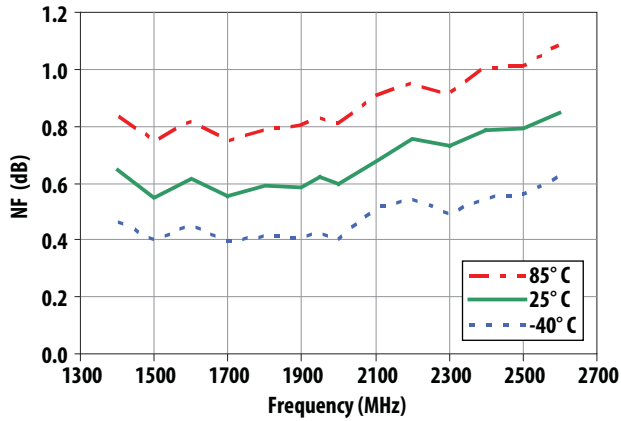

Figure 9. NF vs Frequency and Temperature

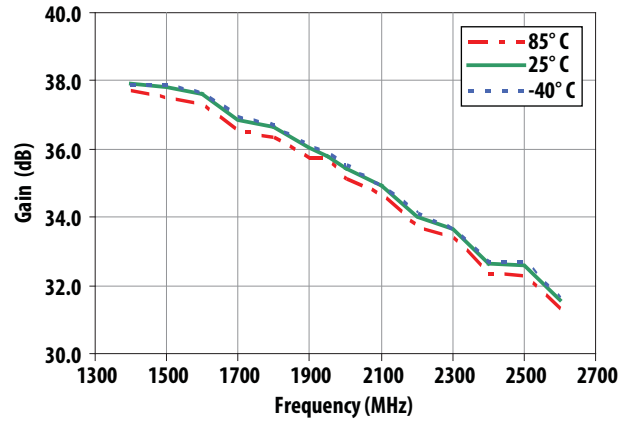

Figure 10. Gain vs Frequency and Temperature

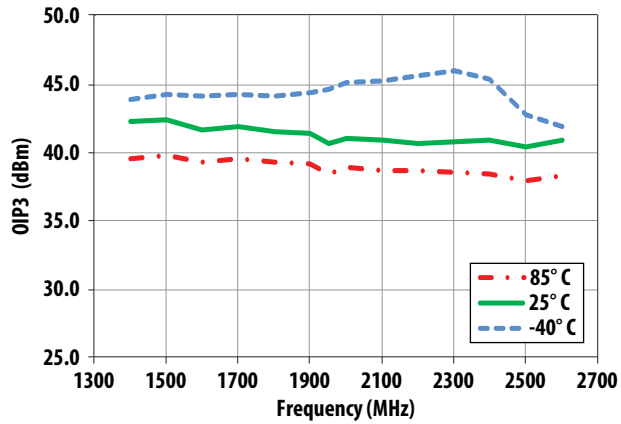

Figure 11. OIP3 vs Frequency and Temperature

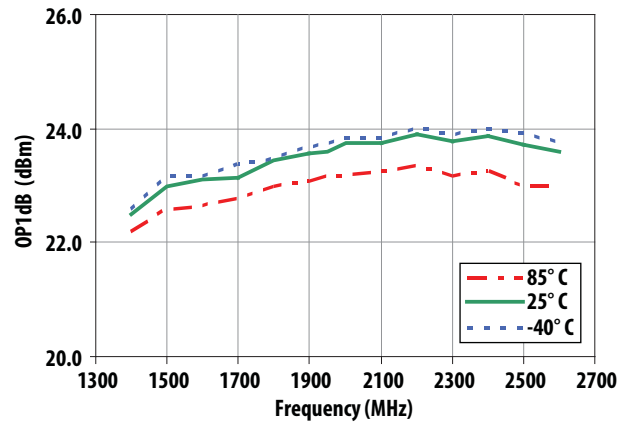

Figure 12. OP1dB vs Frequency and Temperature

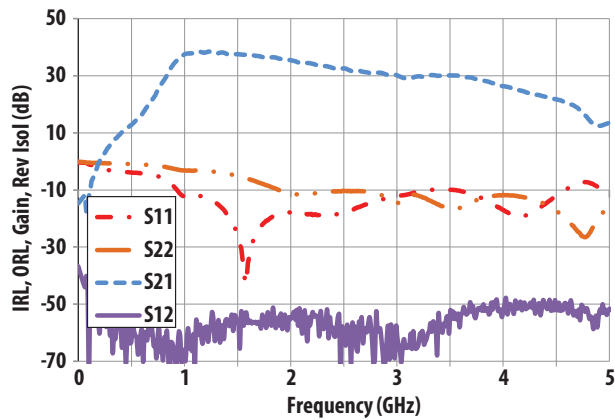

Figure 13. Input Return Loss, Output Return Loss, Gain, & Reverse Isolation vs Frequency

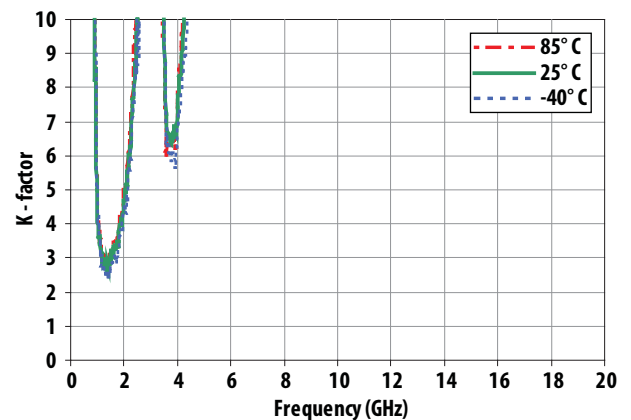

Figure 14. K-factor vs Frequency and Temperature

MGA-13216 Typical Performance in Demoboard for 1.95 GHz

$T_A = 25^\circ\text{C}$, $V_{dd1} = 5.0\text{V}$, $V_{dd2} = 5.0\text{V}$, $I_{dd1} = 53\text{mA}$, $I_{dd2} = 122\text{mA}$

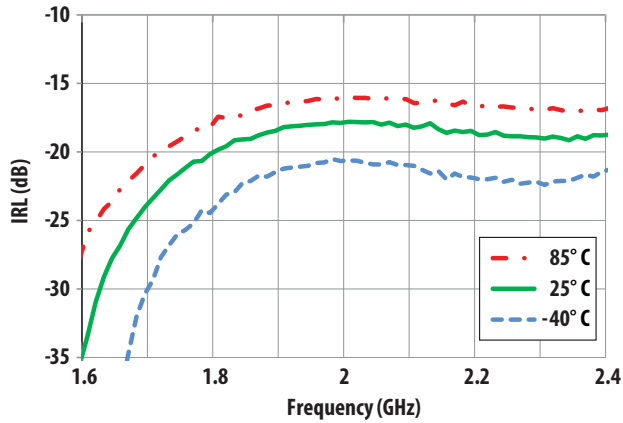

Figure 15. IRL vs Frequency and Temperature

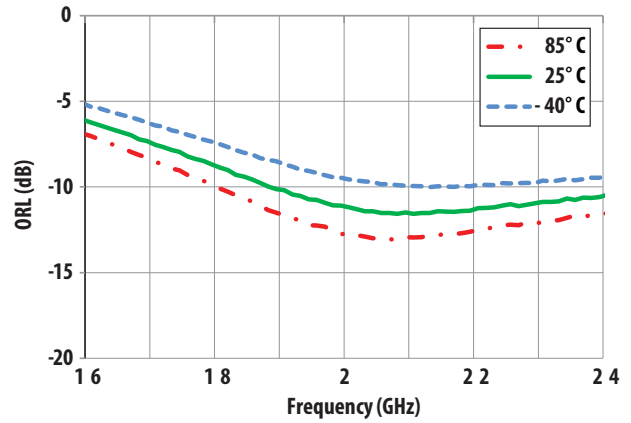

Figure 16. ORL vs Frequency and Temperature

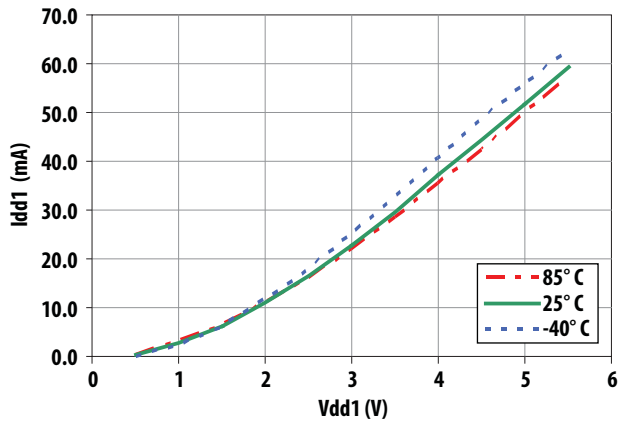

Figure 17. Idd1 vs Vdd1 and Temperature

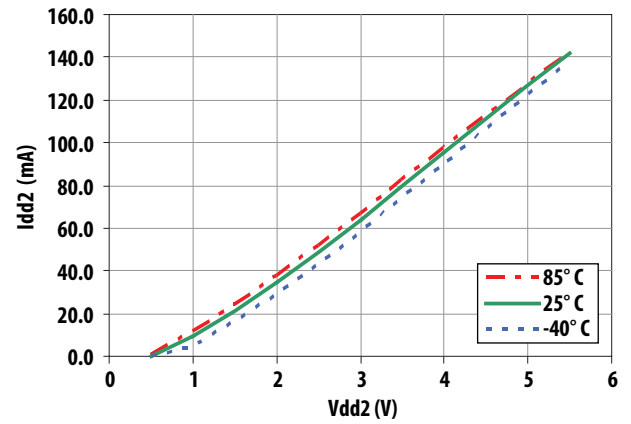

Figure 18. Idd2 vs Vdd2 and Temperature

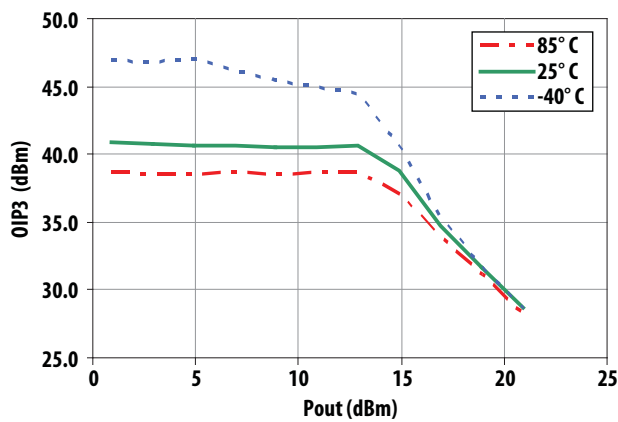
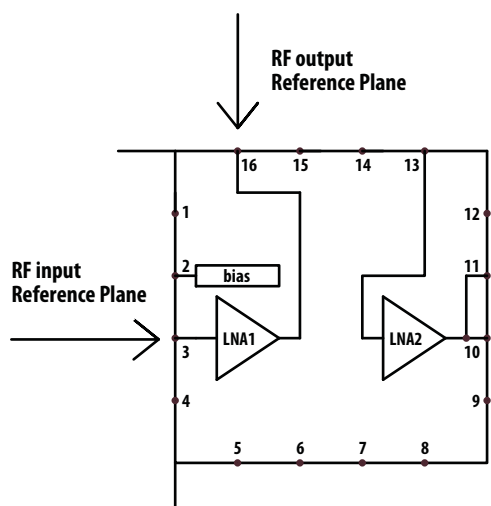

Figure 19. OIP3 vs Output Power and Temperature at 1.95 GHz

MGA-13216 Q1 Typical Scattering Parameters, Vdd1 = 5 V, Idd1 = 53 mA

Freq GHz	S11		S21		S12		S22	
	Mag.	Ang.	Mag.	Ang.	Mag.	Ang.	Mag.	Ang.
0.1	0.90	-16.98	37.00	157.64	0.00	48.80	0.54	-16.53
0.5	0.58	-57.10	20.73	112.16	0.01	60.00	0.34	-25.47
0.9	0.41	-78.09	13.42	89.11	0.02	63.96	0.31	-32.94
1.0	0.39	-82.31	12.28	84.68	0.02	64.17	0.30	-35.72
1.5	0.33	-100.68	8.73	65.57	0.03	63.16	0.27	-49.87
1.9	0.32	-111.98	7.10	52.31	0.03	61.03	0.24	-65.97
2.0	0.32	-114.21	6.78	49.09	0.03	60.41	0.23	-70.70
2.5	0.32	-123.78	5.58	33.68	0.04	56.77	0.22	-97.67
3.0	0.32	-131.52	4.74	18.62	0.05	52.16	0.24	-124.98
4.0	0.34	-147.74	3.62	-10.88	0.07	42.70	0.33	-170.16
5.0	0.43	-160.90	2.85	-40.35	0.09	31.33	0.43	152.86
6.0	0.46	-173.17	2.32	-73.07	0.11	15.51	0.57	108.56
7.0	0.42	164.51	1.65	-104.52	0.11	-1.13	0.75	79.33
8.0	0.49	144.57	1.15	-128.97	0.12	-12.89	0.85	66.43
9.0	0.58	135.92	0.87	-153.00	0.13	-25.90	0.88	50.13
10.0	0.59	123.84	0.68	179.70	0.14	-43.85	0.88	25.49
11.0	0.56	104.66	0.49	153.85	0.14	-61.82	0.94	3.72
12.0	0.62	95.03	0.35	133.97	0.14	-74.64	0.96	-8.28
13.0	0.61	83.60	0.24	114.00	0.13	-88.86	0.96	-9.97
14.0	0.57	77.47	0.16	101.52	0.12	-96.62	0.95	-11.26
15.0	0.69	63.81	0.13	83.57	0.13	-112.30	0.95	-22.26
16.0	0.78	48.65	0.09	58.50	0.13	-140.70	0.92	-43.28
17.0	0.77	31.46	0.07	45.20	0.11	-172.63	0.90	-59.64
18.0	0.74	-5.87	0.09	33.11	0.06	123.08	0.87	-70.19
19.0	0.35	-60.87	0.16	-30.74	0.15	-74.65	0.81	-81.91
20.0	0.40	60.14	0.15	-133.62	0.27	-168.80	0.59	-91.00



Notes: Measurements are made on 10 mils Rogers R04350 TRL Board. Figure 20 shows the input and output reference plane for Q1.

Figure 20.

MGA-13216 Q2 Typical Scattering Parameters, Vdd2 = 5 V, Idd2 = 122 mA

Freq GHz	S11		S21		S12		S22	
	Mag.	Ang.	Mag.	Ang.	Mag.	Ang.	Mag.	Ang.
0.1	0.87	171.29	0.14	-111.79	0.00	88.11	0.82	173.63
0.5	0.85	138.30	1.52	-81.16	0.01	96.29	0.77	145.63
0.9	0.69	96.98	5.52	-124.77	0.03	86.36	0.56	112.53
1.0	0.59	84.76	6.84	-140.78	0.03	78.00	0.46	104.58
1.5	0.18	130.00	9.14	138.88	0.05	25.63	0.23	144.28
1.9	0.30	121.10	8.18	98.15	0.05	-1.96	0.28	138.20
2.0	0.30	114.38	8.01	89.78	0.05	-7.84	0.28	135.20
2.5	0.21	68.24	7.54	51.45	0.04	-38.95	0.19	126.38
3.0	0.15	-47.90	7.51	11.84	0.03	-81.84	0.11	159.70
4.0	0.66	169.12	5.52	-78.67	0.02	135.07	0.26	144.46
5.0	0.96	114.66	2.62	-162.85	0.03	69.66	0.16	-134.63
6.0	0.90	85.78	0.78	134.59	0.04	39.96	0.44	-174.12
7.0	0.90	66.82	0.29	99.54	0.04	20.92	0.45	142.19
8.0	0.97	49.53	0.15	61.95	0.04	2.45	0.58	118.39
9.0	0.94	31.72	0.07	18.92	0.03	-23.65	0.69	89.18
10.0	0.96	16.48	0.02	-2.22	0.00	-27.52	0.68	32.18
11.0	0.96	7.02	0.03	70.89	0.02	72.90	0.85	-28.05
12.0	0.97	-0.97	0.04	37.99	0.04	32.78	0.66	-92.36
13.0	0.91	-10.74	0.03	8.76	0.04	0.04	0.57	-160.08
14.0	0.95	-16.10	0.01	-6.28	0.01	-30.22	0.55	139.91
15.0	0.98	-24.91	0.02	119.58	0.02	136.32	0.59	97.39
16.0	0.94	-41.02	0.05	107.64	0.05	111.77	0.65	67.01
17.0	0.96	-54.68	0.09	88.59	0.09	90.04	0.66	37.97
18.0	0.95	-63.44	0.15	61.31	0.15	61.66	0.70	5.63
19.0	0.88	-61.13	0.19	1.11	0.19	1.14	0.52	-29.99
20.0	0.92	-57.92	0.11	55.82	0.11	55.64	0.47	-2.21

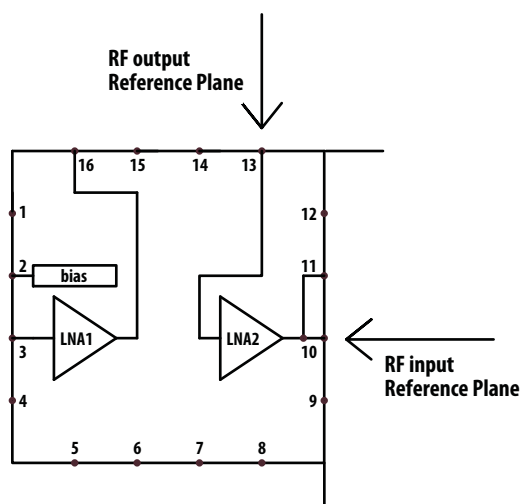
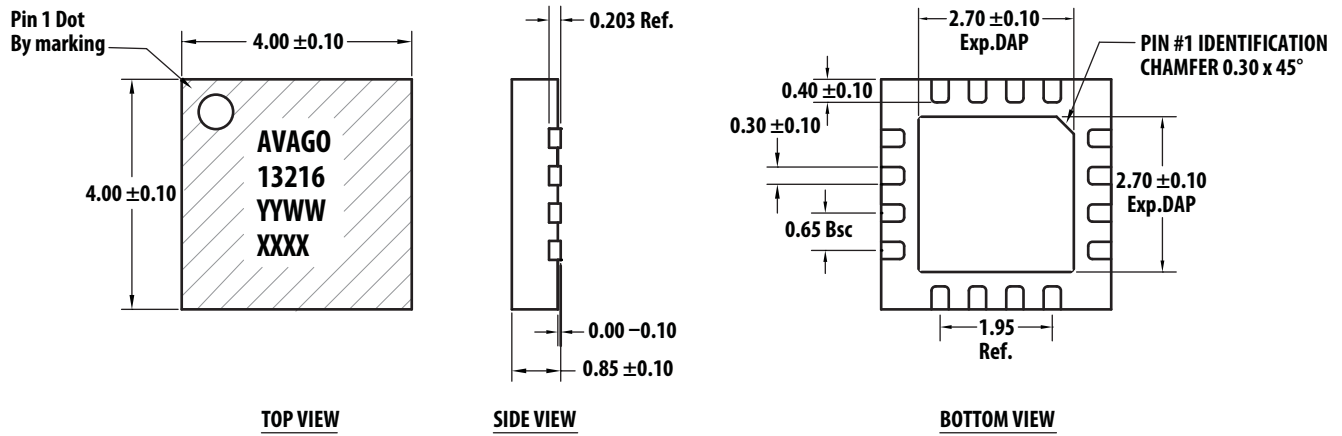

Figure 21.

Notes: Measurements are made on 10 mils Rogers R04350 TRL Board. Figure 21 shows the input and output reference plane for Q2.

Package Dimensions



PCB Land Patterns and Stencil Design

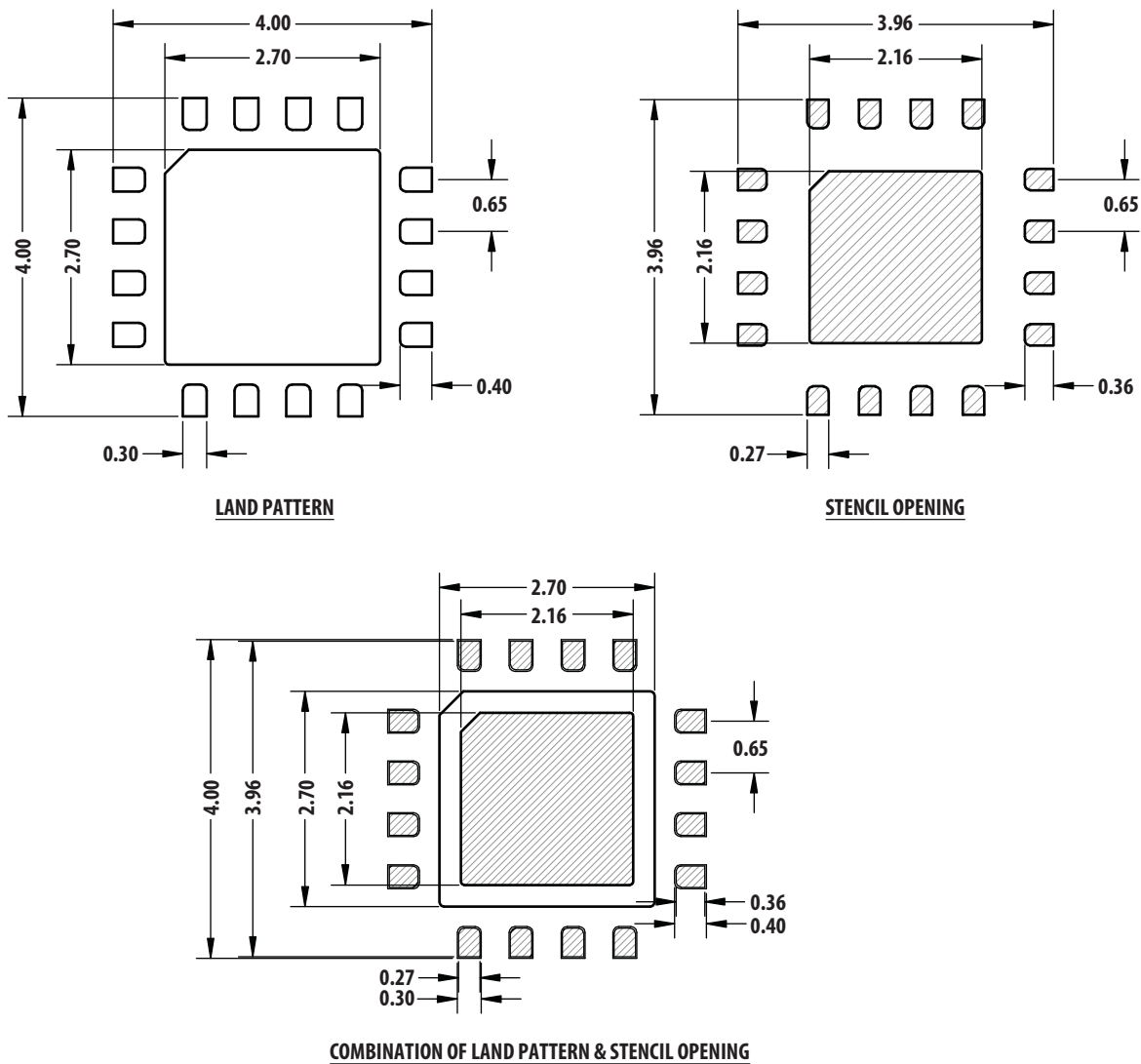

Notes:

1. All dimensions are in millimeters.
2. 4 mil stencil thickness recommended.

Device Orientation

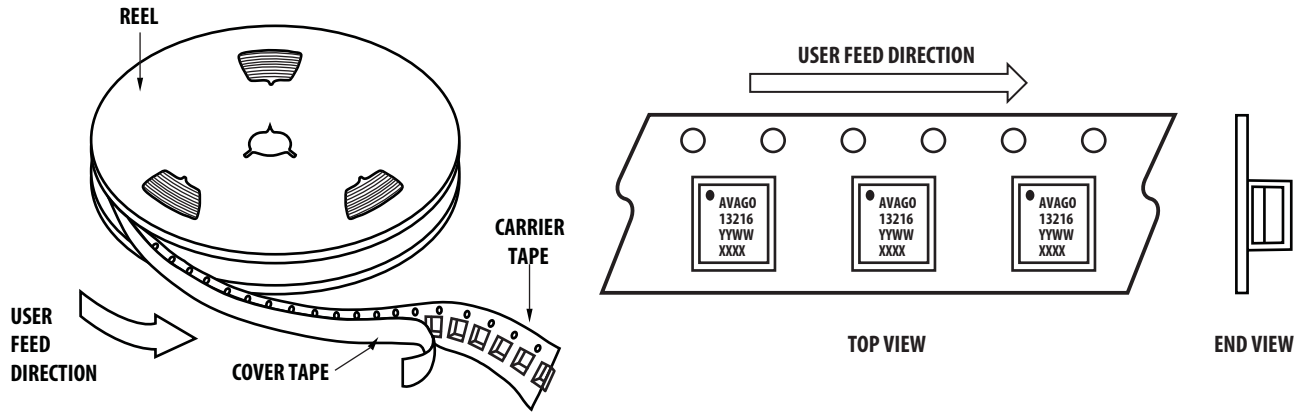

Tape Dimensions

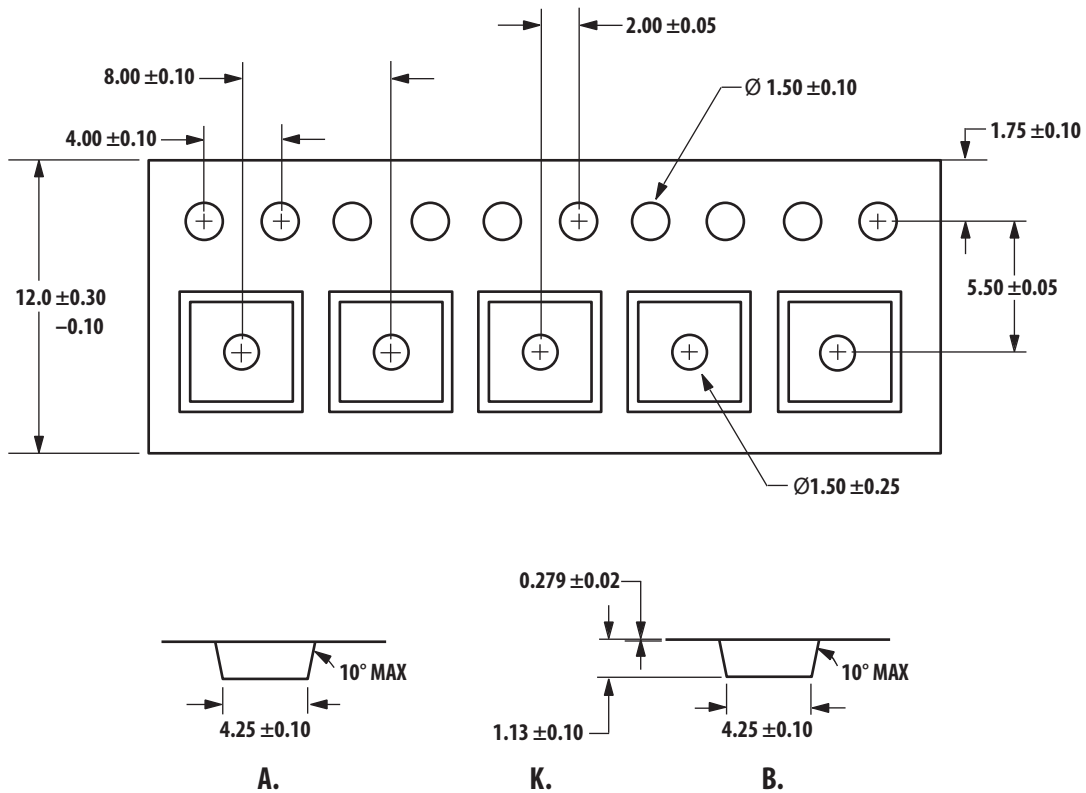

Part Number Ordering Information

Part Number	No. of Devices	Container
MGA-13216-TR1G	1000	7" Reel
MGA-13216-BLKG	100	antistatic bag

Reel Dimensions (7 inch reel)

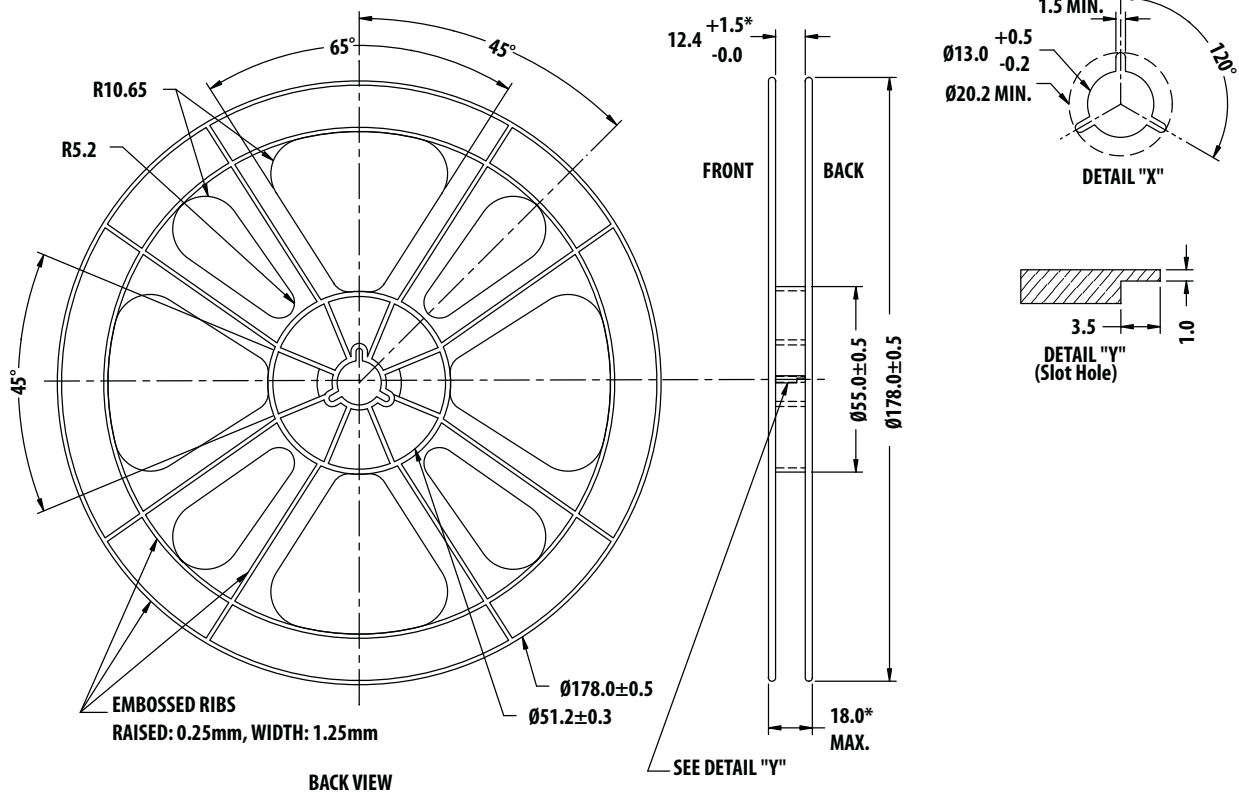
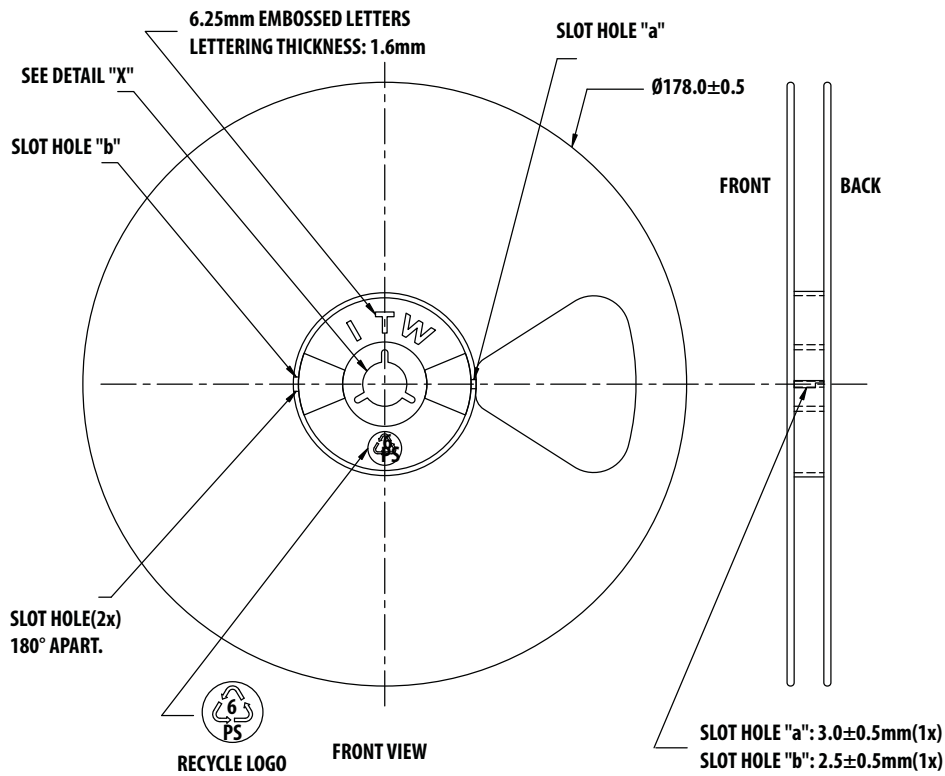

For product information and a complete list of distributors, please go to our web site: www.avagotech.com

Avago, Avago Technologies, and the A logo are trademarks of Avago Technologies in the United States and other countries.
Data subject to change. Copyright © 2005-2011 Avago Technologies. All rights reserved.
AV02-2878EN - May 3, 2011

