

LM6066

LCD Module User Manual

Shenzhen TOPWAY Technology Co., Ltd.

Rev.	Descriptions	Release Date
0.1	New release	2006-06-21

Table of Content

1. Basic Specifications	3
1.1 Display Specifications	3
1.2 Mechanical Specifications	3
1.3 Block Diagram	3
1.4 Terminal Functions	4
2. Absolute Maximum Ratings	5
3. Electrical Characteristics	5
3.1 DC Characteristics	5
3.2 LED Backlight Circuit Characteristics	5
3.3 AC Characteristics	6
4. Function Specifications	7
4.1 Adjusting the Display Contrast	7
4.2 Resetting the LCD module	7
4.3 Display Pixel Map	7
4.4 Control Data and Command	8
4.5 Register Table	8
4.6 Initialization Setting Example	11
5. Design and Handling Precaution	12

1. Basic Specifications

1.1 Display Specifications

- 1) LCD Display Mode : STN, Negative, Transmissive
- 2) Display Color : Display Data = "1" : Light Gray (*1)
: Display Data = "0" : Deep Blue (*2)
- 3) Viewing Angle : 6 H
- 4) Driving Method : 1/64 duty, 1/9 bias
- 5) Backlight : White LED backlight

Note:

*1. Color tone may slightly change by Temperature and Driving Condition.

*2. The Color is defined as the inactive / background color

1.2 Mechanical Specifications

- 1) Outline Dimension : 180.0 x 62.0 x 12.3MAX
see attached Outline Drawing for details

1.3 Block Diagram

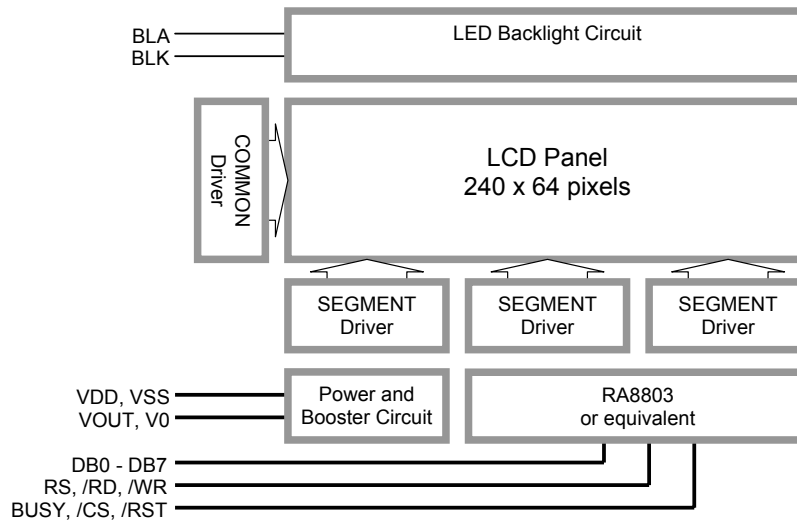

1.4 Terminal Functions

Pin No.	Pin Name	I/O	Descriptions
1	VOUT	Power	Power Booster Output for V0
2	V0	Input	LCD Contrast Reference Input
3	VSS	Power	0V Power Supply, GND
4	VDD	Power	Positive Power Supply
5	BUSY	Output	Controller busy signal, MCU should poll this signal before accessing the LCD module
6	NC	-	No connection (leave open)
7	/CS	Input	Chip Select Signal /CS=LOW: Data IO is enabled
8	RS	Input	Register Select RS=HIGH: data on DB0 to DB7 is display data RS=LOW: data on DB0 to DB7 is control data
9	/WR	Input	Write enable input, active LOW
10	/RD	Input	Read enable input, active LOW
11	DB0	I/O	8-bit bi-directional data bus
:	:		
18	DB7		
19	/RST	Input	Reset Signal: /RST = L, Reset the LCD Module /RST = H, Normal Running
20	NC	-	No connection (leave open)
21,23,25	BLA	Power	Positive Power Supply for LED backlight
22,24,26	BLK	Power	Negative Power Supply for LED backlight

Note: For enable BUSY output, the REG[A0] D0, D1, D2 or D3 should be set to hi.

Absolute Maximum Ratings

Items	Symbol	Min.	Max.	Unit	Condition
Supply Voltage	V_{DD}	0	+5.5	V	$V_{SS} = 0V$
Input Voltage	V_{IN}	$V_{SS}-0.3$	$V_{DD}+0.3$	V	$V_{SS} = 0V$
Operating Temperature	T_{OP}	-20	+70	°C	No Condensation
Storage Temperature	T_{ST}	-30	+80	°C	No Condensation

Cautions:

Any Stresses exceeding the Absolute Maximum Ratings may cause substantial damage to the device. Functional operation of this device at other conditions beyond those listed in the specification is not implied and prolonged exposure to extreme conditions may affect device reliability.

2. Electrical Characteristics

2.1 DC Characteristics

$V_{SS}=0V, V_{DD} =5.0V, T_{OP} =25^{\circ}C$

Items	Symbol	MIN.	TYP.	MAX.	Unit	Applicable Pin
Operating Voltage	V_{DD}	4.7	5.0	5.3	V	VDD
Input High Voltage	V_{IN}	0.8xVDD	-	VDD	V	DB0~DB7, /WR, /RD, /CS, RS, /RST
Input Low Voltage	V_{IN}	VSS	-	0.1xVDD	V	DB0~DB7, /WR, /RD, /CS, RS, /RST
Operating Current	I_{DD}	-	6.0	18.0	mA	VDD

2.2 LED Backlight Circuit Characteristics

$BLK=0V, I_{f_{BLA}}=165mA, T_{OP} =25^{\circ}C$

Items	Symbol	MIN.	TYP.	MAX.	Unit	Applicable Pin
Forward Voltage	$V_{f_{BLA}}$	-	5.0	-	V	BLA
Forward Current	$I_{f_{BLA}}$	-	165	200	mA	BLA

Cautions:

Exceeding the recommended driving current could cause substantial damage to the backlight and shorten its lifetime.

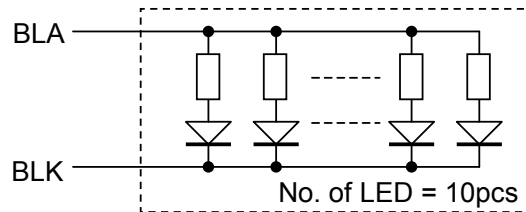

2.3 AC Characteristics

$V_{SS}=0V, V_{DD}=5.0V, T_{OP}=25^{\circ}C$

Item	Symbol	MIN.	TYP.	MAX.	Unit
Address Hold Time	tah8	13	-	-	Ns
Address Setup Time	taw8	79	-	-	Ns
System Cycle Time	tcyc8	1000	-	-	Ns
Strobe Pulse Width	tcc8	500	-	-	Ns
Data Setup Time	tds8	79	-	-	
Data Hold Time	tdh8	13	-	-	Ns
Data Access Time	tacc8	-	-	413	Ns
Output disable Time	toh8	13	-	-	Ns

Note: *1. Input signal rise/fall time should be less than 20ns

*2. System clock=8MHz

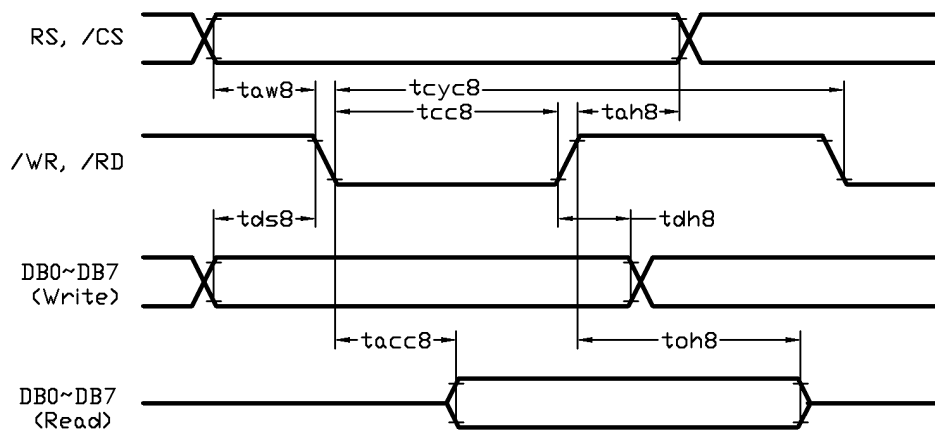

Bus Timing Diagram

2.3.1 Reset Timing

$V_{SS}=0V, V_{DD}=5.0V, T_{OP}=25^{\circ}C$

Item	Symbol	MIN.	TYP.	MAX.	Unit
Reset Time	trst	320	-	-	ms
Reset LOW pulse width	trsth	65	-	-	ms

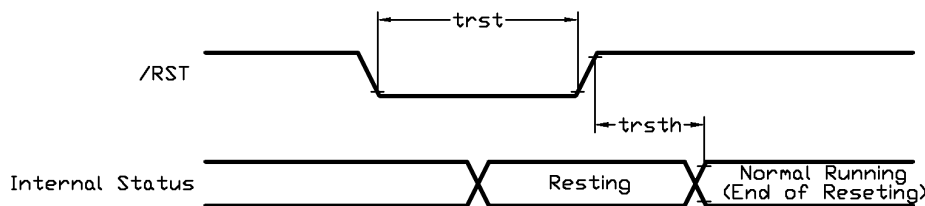

Reset Timing Diagram

3. Function Specifications

3.1 Adjusting the Display Contrast

A Variable-Resistor must be connected to the LCD module for providing a reference to V0. Adjusting the VR will result the change of LCD display contrast. The recommended value of VR is 25k to 50k

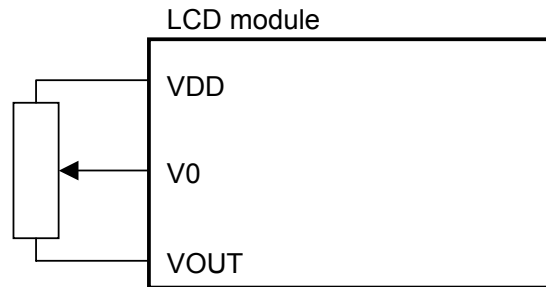

3.2 Resetting the LCD module

The LCD module should be initialized by using /RST terminal.

While turning on the VDD and VSS power supply, maintain /RST terminal at LOW level. After the power supply stabilized, release the reset terminal (/RST=HIGH)

3.3 Display Pixel Map

1,1 (D7)	2,1 (D6)	3,1 (D5)	4,1 (D4)	5,1 (D3)	---	---	236,1 (D4)	237,1 (D3)	238,1 (D2)	239,1 (D1)	240,1 (D0)
1,2 (D7)	2,2 (D6)	3,2 (D5)	4,2 (D4)	5,2 (D3)	---	---	236,2 (D4)	237,2 (D3)	238,2 (D2)	239,2 (D1)	240,2 (D0)
1,3 (D7)	2,3 (D6)	3,3 (D5)	4,3 (D4)	5,3 (D3)	---	---	236,3 (D4)	237,3 (D3)	238,3 (D2)	339,3 (D1)	240,3 (D0)
:	:	:	:	:	:	:	:	:	:	:	:
:	:	:	:	:	:	:	:	:	:	:	:
:	:	:	:	:	:	:	:	:	:	:	:
1,62 (D7)	2,62 (D6)	3,62 (D5)	4,62 (D4)	5,62 (D3)	---	---	236,62 (D4)	237,62 (D3)	238,62 (D2)	239,62 (D1)	240,62 (D0)
1,63 (D7)	2,63 (D6)	3,63 (D5)	4,63 (D4)	5,63 (D3)	---	---	236,63 (D4)	237,63 (D3)	238,63 (D2)	239,63 (D1)	240,63 (D0)
1,64 (D7)	2,64 (D6)	3,64 (D5)	4,64 (D4)	5,64 (D3)	---	---	236,64 (D4)	237,64 (D3)	238,64 (D2)	239,64 (D1)	240,64 (D0)

Pixel mapping (Top View)

Based on the top view of the LCD module, the 1, 1 (x, y) pixel is the upper-left pixel; the 240, 64 (x, y) pixel is the lower-right pixel.

Note:

*1. For the details of memory mapping please refer to RA8803 datasheet.

3.4 Control Data and Command

The LCD module setting is controlled by the internal Register Values. The Register Address and Register Value should be issued in sequence and they are addressed as Control Data.

A full command sequence should be as follow.

Steps	/RD	/WR	RS	Data (DB0~ DB7)
1 st	1	0	0	Register Address
2 nd	1	0	0	Register Value

3.5 Register Table Summary

Reg. Add	Reg. Name	R/W	D7	D6	D5	D4	D3	D2	D1	D0	Descriptions
00h	WLCR	R/W	PW1	PW0	SR	CG	DP	BK	DV		PW1~PW0 : Power Mode 11=Normal Mode; 00=Off Mode SR : Software Reset 1=reset all register (except DDRAM); 0=normal operation CG : Display mode selection 1=Character Mode; 0=Graphic Mode DP : Display on off control 1=normal display; 0=display off BK : Full screen blinking control 1=blinking (blink time is set by CBTR); 0=normal; DV : Full screen inverse control 1=normal; 0=inversed
01h	MISC	R/W	1	CKN	PLR			CKB1	CKB0		CKN : Clock output Control (not applicable) 1=enable; 0=disable PLR : Interrupt and Busy Polarity (not applicable) 1=active High; 0=active low CKB1~CKB0 : Clock Speed Selection 00=3MHz; 01=4MHz; 10=8MHz; 11=12MHz
02h	APSR	R/W			SP1	SP0	ORA	SRFS			SP1~SP0 : ROM/RAM reading speed 00=speed0; 01=speed1; 10=speed2; 11=speed3 ORA : Font ROM Readable 1=enable; 0=disable SRFS : Scrolling Reset for Start 1=enable; 0=disable
03h	ADSR	R/W					DADR	AUCM	AUSG	SGCM	DADR : Display RAM Order (byte) 1=reverse; 0=normal AUCM : Common Auto Scrolling 1=enable; 0=disable AUSG : Segment Auto Scrolling 1=enable; 0=disable Common or Segment Scrolling Selection 1=Segment Scrolling; 0=Common Scrolling
10h	WCCR	R/W	ARI	ALG	WDI	WBC	AIX	CP	CK	CSD	ARI : Auto-increase Cursor Position (in reading DDRAM operation) 1=enable; 0=disable ALG : Chinese/English char alignment 1=enable; 0=disable WDI : Store Current Data to DDRAM 1=directly; 0=invertly WBC : Set Bold font (char mode only) 1=bold; 0=normal AIX : Auto-increase Cursor Position (in writing DDRAM operation) 1=enable; 0=disable CP : Cursor display control 1=on; 0=off CK : Cursor blink control 1=blinking; 0=no blinking CSD : Set cursor width 1=auto adjust, 0=fix width
11h	DWLR	R/W	CR3	CR2	CR1	CR0	DY3	DY2	DY1	DY0	CR3~CR0 : Cursor Height DY3~DY0 : Line Distance

Register Table Summary (cont')

Reg. Add	Reg. Name	R/W	D7	D6	D5	D4	D3	D2	D1	D0	Descriptions
12h	MAMR	R/W	GIM	RM2	RM1	RM0	OP1	OP2	WM1	WM0	GIM : Graphic Mode Cursor Auto Shifting Direction 1=Horizontal then Vertical; 0=Vertical then Horizontal RM2~RM0 : Display Layer Selection 001=page1 only; 010=page2 only; 011=combine two layer; 000=gray scale mode 110=extended mode1, 111=extended mode2 OP1~OP2 : two layer mode setting 00=OR; 01=XOR; 10=NOR; 11=AND WM1~WM0 : Layer Read/Write Selection 00=page0; 01=page1; 10=page2; 11=page1 & page2 at the same time
20h	AWRR	R/W	--	--	X5	X4	X3	X2	X1	X0	X5~X0 : Active Window Right Register
21h	DWRR	R/W	--	--	A5	A4	A3	A2	A1	A0	A5~A0 : Display Window Right Register
30h	AWBR	R/W	Y7	Y6	Y5	Y4	Y3	Y2	Y1	Y0	Y7~Y0 : Active Window Bottom Register
31h	DWBR	R/W	B7	B6	B5	B4	B3	B2	B1	B0	B7~B0 : Display Window Bottom Register
40h	AWLR	R/W	--	--	SS5	SS4	SS3	SS2	SS1	SS0	SS5~SS0 : Active Window Left Register
41h	DWLR	R/W	--	--	C5	C4	C3	C2	C1	C0	C5~C0 : Display Window Left Register
50h	AWTR	R/W	SC7	SC6	SC5	SC4	SC3	SC2	SC1	SC0	SC7~SC0 : Active Window Top Register
51h	DWTR	R/W	D7	D6	D5	D4	D3	D2	D1	D0	D7~D0 : Display Window Top Register
60h	CPXR	R/W	--	--	RS5	RS4	RS3	RS2	RS1	RS0	RS5~RS0 : Cursor Poison X Register
61h	BGSG	R/W	--	--	DS5	DS4	DS3	DS2	DS1	DS0	DS5~DS0 : Segment Start Position of Scrolling Mode
70h	CPYR	R/W	RC7	RC6	RC5	RC4	RC3	RC2	RC1	RC0	RC7~RC0 : Cursor Position Y Register
71h	BGCM	R/W	CB7	CB6	CB5	CB4	CB3	CB2	CB1	CB0	CB7~CB0 : Common Start Position of Scrolling Mode
72h	EDCM	R/W	CD7	CD6	CD5	CD4	CD3	CD2	CD1	CD0	CD7~CD0 : Common Ending Position of Scrolling Mode
80h	BTMR	R/W	BT7	BT6	BT5	BT4	BT3	BT2	BT1	BT0	BT7~BT0 : Cursor Blink Time Register
81h	FRCA	R/W	0	0	0	1	1	1	0	1	Frame Rate Polarity Change at Common_A Register
90h	SCCR	R/W	CK7	CK6	CK5	CK4	CK3	CK2	CK1	CK0	CK7~CK0 : Shift Clock Control Register
91h	FRCB	R/W	--	--	--	--	--	--	--	--	Reserved
A0h	INTR	R/W	INK	INT	INX	INTY	MSK	MST	MSX	MSY	INK : Key Scan Interrupt Flag (read only) 1=detected; 0=not detected INT : Touch Panel detect (read only) 1=touched; 0=untouched INX : Cursor Column status (read only) 1=equal to INTX; 0=not equal to INTX INTY : Cursor Row status (read only) 1=equal to INTY; 0=not equal to INTY MSZ : Key Scan Interrupt output and BUSY output 1=enable key scan interrupt; 0=disable key scan interrupt MSA : Touch Panel interrupt output and BUSY output 1=enable; 0=disable MSX : INTX event interrupt output and BUSY output 1=enable; 0=disable MSY : INTY event interrupt output and BUSY output 1=enable; 0=disable (any bit of D0~D3 set to "1" could enable the busy signal output)

Register Table Summary (cont')

Reg. Add	Reg. Name	R/W	D7	D6	D5	D4	D3	D2	D1	D0	Descriptions
A1h <i>(not applicable)</i>	KSCR	R/W	KEN	KSZ	KDT1	KDT0	--	KF2	KF1	KF0	KEN : Key Scan Enable Bit 1=enable; 0=disable KSZ : Key Scan Matrix Selection 1=4x4; 0=8x8 KDT1~KDT0 : Key Scan Data Sampling Times 00=2xFRM; 01=4xFRM; 10=8xFRM; 11=16xFRM KF2~KF0 : Key Scan Frequency Selection 000= 2xFRM, 001=4xFRM; 010=8xFRM; 011=16xFRM 100= 32xFRM, 001=64xFRM; 010=128xFRM; 011=256xFRM
A2h <i>(not applicable)</i>	KSDR	R	KC7	KC6	KC5	KC4	KC3	KC2	KC1	KC0	KC7~KC0 : Key Scan Output
A3h <i>(not applicable)</i>	KSER	R	KR7	KR6	KR5	KR4	KR3	KR2	KR1	KR0	KR7~KR0 : Key Scan Data Input
B0h <i>(not applicable)</i>	INTX	R/W	--	--	IX5	IX4	IX3	IX2	IX1	IX0	IX5~IX0 : Interrupt Column Setup Register
B1h <i>(not applicable)</i>	INTY	R/W	IY7	IY6	IY5	IY4	IY3	IY2	IY1	IY0	IY7~IY0 : Interrupt Row Setup Register
C0h <i>(not applicable)</i>	TPCR	R/W	AZEN	AZOE	--	SCAN	AS3	AS2	AS1	AS0	AZEN : Touch Panel Function 1=enable; 0=disable AZOE : Touch Panel Data Output 1=enable; 0=disable SCAN : Touch Panel Scan 1=enable; 0=disable AS3~AS0 : Touch Panel Control Bits
C1h <i>(not applicable)</i>	TPSR	R/W	ARDY	ADET	1	1	AF1	FA0	--	--	ARDY : ADC Data Convert State 1=convert complete; 0=convert incomplete ADET : Touch Event Indicate 1=touched; 0=untouched
C8h <i>(not applicable)</i>	TPXR	R	TPX9	TPX8	TPX7	TPX6	TPX5	TPX4	TPX3	TPX2	TPX9~TPX2 : Touch Panel Segment data D9~D2
C9h <i>(not applicable)</i>	RPYR	R	TPY9	TPY8	TPY7	TPY6	TPY5	TPY4	TPY3	TPY2	TPY9~TPY2 : Touch Panel Common data D9~D2
CAh <i>(not applicable)</i>	TPZR	R	TPX1	TPX0	--	--	TPY1	TPY0	--	--	TPX1~TPX0 : Touch Panel Segment data D1~D0 TPY1~TPY0 : Touch Panel Common data D1~D0
D0h <i>(not applicable)</i>	LCCR	R/W	DZEN	--	--	DAC4	DAC3	DAC2	DAC1	DAC0	DZEN : LCD contrast control 1=disable; 0=enable DAC4~DAC0 : LCD Contrast Control Value
E0h	PNDR	R/W	FD7	FD6	FD5	FD4	FD3	FD2	FD1	FD0	FD7~FD0 : Pattern Data Register / Display Times of Gray Mode
F0h	FNCR	R/W	TNS	BNK	RM1	RM0	FDA	ASC	ABS1	ABS0	TNS : External Char ROM 1=enable; 0=disable BNK : ROM BANK Selection 1=Lower 256k ROM; 0=upper 256k ROM RM1~RM0 : Font ROM Translate 00=GB(256k); 01=BIG5(512k); 10=GB(512k) FDA : Fill Data to DDRAM 1=fill data to DDRAM enable; 0=no action; ASC : Font ROM range select 1=decode as ASCII; 0=auto ABS1~ABS0 : ASCII Block Selection 00=map to ASCII block 0; 01=map to ASCII block 1; 10=map to ASCII block 2; 11=map to ASCII block 3
F1h	FVHT	R/W	FH1	FH0	FV1	FV0	1	1	1	1	FH1~FH0 : Font Horizontal Size 00=1x; 01=2x; 10=3x; 11=4x FV1~FV0 : Font Vertical Size 00=1x; 01=2x; 10=3x; 11=4x

Note:

- *1. It is suggested to check the BUSY before sending the Control Data.
- *2. For the details, please refer to RA8803 Data sheet.

3.6 Initialization Setting Example

The following setting should be issue to LCD module after hardware reset.
(It is a basic example only; it could be adjusted if necessary.)

Register Add	Register Name	Value (binary)	Value (hex)	Note
00h	WLCR	1100 1101	CD	Power Mode = Normal Mode Software Reset = Normal Operation Display mode = Character Mode Display on off control = normal display Full screen blinking control = normal (no blinking) Full screen inverse = normal (no inverse)
10h	WCCR	0010 1001	29	Auto-increase Cursor Position (in reading DDRAM operation) = disable Chinese/English char alignment = disable Store Current Data to DDRAM = directly Set Bold font (char mode only) = normal Auto-increase Cursor Position (in writing DDRAM operation) = enable Cursor display control = off Cursor blink control = no blinking Set cursor width = auto adjust
11h	DWLR	0001 0000	10	Cursor Height = 1 Line Distance = 0
20h	AWRR	0001 0111	1D	Active Window Right Register = 1D
21h	DWRR	0001 0111	1D	Display Window Right Register = 1D
30h	AWBR	0111 1111	3F	Active Window Bottom Register = 3F
31h	DWBR	1000 0000	3F	Display Window Bottom Register = 3F
40h	AWLR	0000 0000	00	Active Window Left Register = 00
41h	DWLR	0000 0000	00	Display Window Left Register = 00
50h	AWTR	0000 0000	00	Active Window Top Register = 00
51h	DWTR	0000 0000	00	Display Window Top Register = 00
81h	FRCA	0100 0000	40	Frame Rate Polarity Change at Common_A Register
90h	SCCR	0001 0101	15	Shift Clock Control Register (set to ~69Hz, when system clock=3MHz)
A0h	INTR	0000 1000	08	Enable the BUSY output with Key Scan Interrupt output
F0h	FNCR	1010 0000	A0	External Char ROM = enable ROM BANK Selection = upper 256k ROM Font ROM Translate = GB Fill Data to DDRAM = no action Font ROM range select = auto ASCII Block Selection = map to ASCII block 0

Note:

Others un-mentioned registers are using its hardware reset default value.

4. Design and Handling Precaution

1. The LCD panel is made by glass. Any mechanical shock (eg. dropping from high place) will damage the LCD module.
2. Do not add excessive force on the surface of the display, which may cause the Display color change abnormally.
3. The polarizer on the LCD is easily get scratched. If possible, do not remove the LCD protective film until the last step of installation.
4. Never attempt to disassemble or rework the LCD module.
5. Only Clean the LCD with Isopropyl Alcohol or Ethyl Alcohol. Other solvents (eg. water) may damage the LCD.
6. When mounting the LCD module, make sure that it is free from twisting, warping and distortion.
7. Ensure to provide enough space (with cushion) between case and LCD panel to prevent external force adding on it, or it may cause damage to the LCD or degrade the display result.
8. Only hold the LCD module by its side. Never hold LCD module by add force on the heat seal or TAB.
9. Never add force to component of the LCD module. It may cause invisible damage or degrade of the reliability.
10. LCD module could be easily damaged by static electricity. Be careful to maintain an optimum anti-static work environment to protect the LCD module.
11. When peeling off the protective film from LCD, static charge may cause abnormal display pattern. It is normal and will resume to normal in a short while.
12. Take care and prevent get hurt by the LCD panel sharp edge.
13. Never operate the LCD module exceed the absolute maximum ratings.
14. Keep the signal line as short as possible to prevent noisy signal applying to LCD module.
15. Never apply signal to the LCD module without power supply.
16. IC chip (eg. TAB or COG) is sensitive to the light. Strong lighting environment could possibly cause malfunction. Light sealing structure casing is recommend.
17. LCD module reliability may be reduced by temperature shock.
18. When storing the LCD module, avoid exposure to the direct sunlight, high humidity, high temperature or low temperature. They may damage or degrade the LCD module