



Improved, Ultra Low Noise $\pm 1 g$ Dual Axis Accelerometer with Digital Outputs

MXD2020GL/HL MXD2020ML/NL

FEATURES

- Resolution better than 1 milli-g
- Dual axis accelerometer fabricated on a monolithic CMOS IC
- On chip mixed mode signal processing
- No moving parts
- 50,000 g shock survival rating
- 17 Hz bandwidth expandable to >160 Hz
- 3.0V to 5.25V single supply continuous operation
- Continuous self test
- Independent axis programmability (special order)
- Compensated for Sensitivity over temperature
- Ultra low initial Zero-g Offset

APPLICATIONS

- Automotive** – Vehicle Security/Vehicle stability control/
Headlight Angle Control/Tilt Sensing
- Security** – Gas Line/Elevator/Fatigue Sensing
- Information Appliances** – Computer Peripherals/PDA's/Mouse
Smart Pens/Cell Phones
- Gaming** – Joystick/RF Interface/Menu Selection/Tilt Sensing
- GPS** – electronic Compass tilt Correction
- Consumer** – LCD projectors, pedometers, blood pressure
Monitor, digital cameras

GENERAL DESCRIPTION

The MXD2020GL/HL/ML/NL is a low cost, dual axis accelerometer fabricated on a standard, submicron CMOS process. It is a complete sensing system with on-chip mixed mode signal processing. The MXD2020GL/HL/ML/NL measures acceleration with a full-scale range of $\pm 1 g$ and a sensitivity of 20%/g. It can measure both dynamic acceleration (e.g. vibration) and static acceleration (e.g. gravity). The MXD2020GL/HL/ML/NL design is based on heat convection and requires no solid proof mass. This eliminates stiction and particle problems associated with competitive devices and provides shock survival of 50,000 g, leading to significantly lower failure rate and lower loss due to handling during assembly.

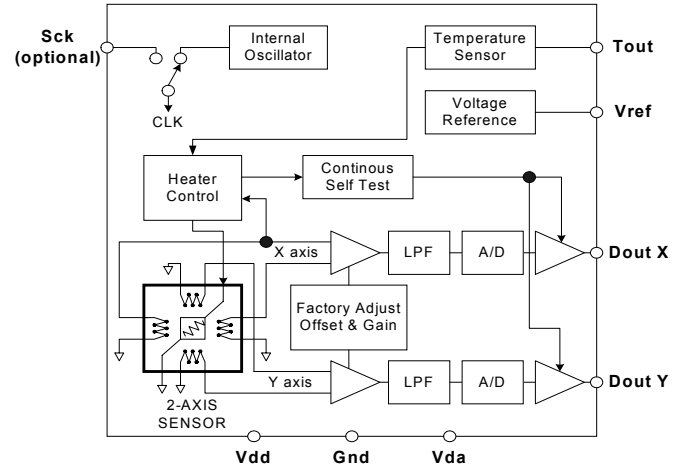

MXD2020GL/HL/ML/NL FUNCTIONAL BLOCK
DIAGRAM

The MXD2020GL/HL/ML/NL provides two digital outputs that are set to 50% duty cycle at zero g acceleration. The outputs are digital with duty cycles (ratio of pulse width to period) that are proportional to acceleration. The duty cycle outputs can be directly interfaced to a micro-processor.

The typical noise floor is $0.2 \text{ mg}/\sqrt{\text{Hz}}$ allowing signals below 1 milli-g to be resolved at 1 Hz bandwidth. The MXD2020GL/HL/ML/NL is packaged in a hermetically sealed LCC surface mount package (5 mm x 5 mm x 2 mm height) and is operational over a -40°C to 105°C (M/NL) and 0°C to 70°C (G/HL) temperature range.

Information furnished by MEMSIC is believed to be accurate and reliable. However, no responsibility is assumed by MEMSIC for its use, nor for any infringements of patents or other rights of third parties which may result from its use. No license is granted by implication or otherwise under any patent or patent rights of MEMSIC.

©MEMSIC, Inc.
800 Turnpike St., Suite 202, North Andover, MA 01845
Tel: 978.738.0900 Fax: 978.738.0196
www.memsic.com

MXD2020GL/HL/ML/NL SPECIFICATIONS (Measurements @ 25°C, Acceleration = 0 g unless otherwise noted; V_{DD}, V_{DA} = 5.0V unless otherwise specified)

Parameter	Conditions	MXD2020G/HL			MXD2020M/NL			Units
		Min	Typ	Max	Min	Typ	Max	
SENSOR INPUT	Each Axis							
Measurement Range ¹		±1.0			±1.0			g
Nonlinearity	Best fit straight line		0.5			0.5		% of FS
Alignment Error ²	X Sensor to Y Sensor		±1.0			±1.0		degrees
Transverse Sensitivity ³			±2.0			±2.0		%
SENSITIVITY	Each Axis							
Sensitivity, Digital Outputs at pins		19	20	21	19	20	21	% duty cycle/g
D _{OUTX} and D _{OUTY} ⁴ Change over Temperature		-10		+8	-25		+8	%
ZERO g BIAS LEVEL	Each Axis							
0 g Offset ⁴		-0.1	0.0	+0.1	-0.1	0.0	+0.1	g
0 g Duty Cycle ⁴		48	50	52	48	50	52	% duty cycle
0 g Offset over Temperature	Based on 20%/g		±1.5			±1.5		mg/°C
			±0.03			±0.03		%/°C
NOISE PERFORMANCE								
Noise Density, rms			0.2	0.4		0.2	0.4	mg/√Hz
FREQUENCY RESPONSE								
3dB Bandwidth		12	17		12	17		Hz
TEMPERATURE OUTPUT								
T _{out} Voltage		1.21	1.25	1.29	1.21	1.25	1.29	V
Sensitivity		4.6	5.0	5.4	4.6	5.0	5.4	mV/°K
VOLTAGE REFERENCE								
V _{Ref}	@3.0V-5.0V supply	2.4	2.5	2.65	2.4	2.5	2.65	V
Change over Temperature			0.1			0.1		mV/°C
Current Drive Capability	Source			100			100	μA
SELF TEST								
Continuous Voltage at D _{OUTX} , D _{OUTY} under Failure	@5.0V Supply, output rails to supply voltage		5.0			5.0		V
Continuous Voltage at D _{OUTX} , D _{OUTY} under Failure	@3.0V Supply, output rails to supply voltage		3.0			3.0		V
D_{OUTX} and D_{OUTY} OUTPUTS								
Normal Output Range	@5.0V Supply	0.1		4.9	0.1		4.9	V
	@3.0V Supply	0.1		2.9	0.1		2.9	V
Current	Source or sink, @ 3.0V-5.0V supply		100			100		μA
Rise/Fall Time	3.0 to 5.0V supply	90	100	110	90	100	110	nS
Turn-On Time	@5.0V Supply		100			100		mS
	@3.0V Supply		40			40		mS
POWER SUPPLY								
Operating Voltage Range		3.0		5.25	3.0		5.25	V
Supply Current	@ 5.0V	2.7	3.8	4.4	2.7	3.8	4.4	mA
Supply Current ⁴	@ 3.0V	3.2	4.7	5.4	3.2	4.7	5.4	mA
TEMPERATURE RANGE								
Operating Range		0		+70	-40		+105	°C

NOTES

- ¹ Guaranteed by measurement of initial offset and sensitivity.
- ² Alignment error is specified as the angle between the true and indicated axis of sensitivity.
- ³ Transverse sensitivity is the algebraic sum of the alignment and the inherent sensitivity errors.
- ⁴ The device operates over a 3.0V to 5.25V supply range. Please note that sensitivity and zero g bias level will be slightly different at 3.0V operation. For devices to be operated at 3.0V in production, they can be trimmed at the factory specifically for this lower supply voltage operation, in which case the sensitivity and zero g bias

level specifications on this page will be met. Please contact the factory for specially trimmed devices for low supply voltage operation.

ABSOLUTE MAXIMUM RATINGS*

Supply Voltage (V_{DD} , V_{DA})-0.5 to +7.0V
 Storage Temperature-65°C to +150°C
 Acceleration50,000 g

*Stresses above those listed under Absolute Maximum Ratings may cause permanent damage to the device. This is a stress rating only; the functional operation of the device at these or any other conditions above those indicated in the operational sections of this specification is not implied. Exposure to absolute maximum rating conditions for extended periods may affect device reliability.

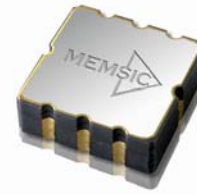

Pin Description: LCC-8 Package

Pin	Name	Description
1	T_{OUT}	Temperature (Analog Voltage)
2	D_{OUTY}	Y-Axis Acceleration Digital Signal
3	Gnd	Ground
4	V_{DA}	Analog Supply Voltage
5	D_{OUTX}	X-Axis Acceleration Digital Signal
6	V_{ref}	2.5V Reference
7	Sck	Optional External Clock
8	V_{DD}	Digital Supply Voltage

Ordering Guide

Model	Package Style	Digital Output	Temperature Range
MXD2020GL	LCC - 8	100 Hz	0 to 70°C
MXD2020HL	LCC - 8	400Hz	0 to 70°C
MXD2020ML	LCC - 8	100 Hz	-40 to 105°
MXD2020NL	LCC - 8	400 Hz	-40 to 105°

All parts are shipped in tape and reel packaging.

Caution: ESD (electrostatic discharge) sensitive device.

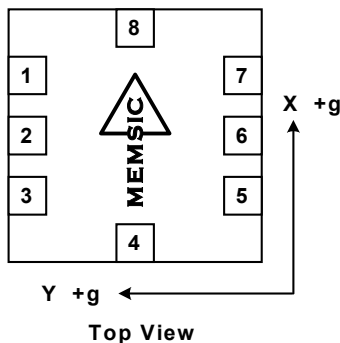

Note: The MEMSIC logo's arrow indicates the +X sensing direction of the device. The +Y sensing direction is rotated 90° away from the +X direction following the right-hand rule.

THEORY OF OPERATION

The MEMSIC device is a complete dual-axis acceleration measurement system fabricated on a monolithic CMOS IC process. The device operation is based on heat transfer by natural convection and operates like other accelerometers having a proof mass. The stationary element, or 'proof mass', in the MEMSIC sensor is a gas.

A single heat source, centered in the silicon chip is suspended across a cavity. Equally spaced aluminum/polysilicon thermopiles (groups of thermocouples) are located equidistantly on all four sides of the heat source (dual axis). Under zero acceleration, a temperature gradient is symmetrical about the heat source, so that the temperature is the same at all four thermopiles, causing them to output the same voltage.

Acceleration in any direction will disturb the temperature profile, due to free convection heat transfer, causing it to be asymmetrical. The temperature, and hence voltage output of the four thermopiles will then be different. The differential voltage at the thermopile outputs is directly proportional to the acceleration. There are two identical acceleration signal paths on the accelerometer, one to measure acceleration in the x-axis and one to measure acceleration in the y-axis. Please visit the MEMSIC website at www.memsic.com for a picture/graphic description of the free convection heat transfer principle.

MXD2020GL/HL/ML/NL PIN DESCRIPTIONS

V_{DD} – This is the supply input for the digital circuits and the sensor heater in the accelerometer. The DC voltage should be between 3.0 and 5.25 volts. Refer to the section on PCB layout and fabrication suggestions for guidance on external parts and connections recommended.

V_{DA} – This is the power supply input for the analog amplifiers in the accelerometer. V_{DA} should always be connected to V_{DD}. Refer to the section on PCB layout and fabrication suggestions for guidance on external parts and connections recommended.

Gnd – This is the ground pin for the accelerometer.

D_{OUTX} – This pin is the digital output of the x-axis acceleration sensor. It is factory programmable to 100 Hz or 400 Hz. The user should ensure the load impedance is sufficiently high as to not source/sink >100µA typical. While the sensitivity of this axis has been programmed at the factory to be the same as the sensitivity for the y-axis, the accelerometer can be programmed for non-equal sensitivities on the x- and y-axes. Contact the factory for additional information.

D_{OUTY} – This pin is the digital output of the y-axis acceleration sensor. It is factory programmable to 100 Hz or 400 Hz. The user should ensure the load impedance is sufficiently high as to not source/sink >100µA typical. While the sensitivity of this axis has been programmed at the factory to be the same as the sensitivity for the x-axis, the accelerometer can be programmed for non-equal sensitivities on the x- and y-axes. Contact the factory for additional information.

T_{OUT} – This pin is the buffered output of the temperature sensor. The analog voltage at T_{OUT} is an indication of the die temperature. This voltage is useful as a differential measurement of temperature from ambient and not as an absolute measurement of temperature.

Sck – The standard product is delivered with an internal clock option (800kHz). **This pin should be grounded when operating with the internal clock.** An external clock option can be special ordered from the factory allowing the user to input a clock signal between 400kHz And 1.6MHz

V_{ref} – A reference voltage is available from this pin. It is set at 2.50V typical and has 100µA of drive capability.

DISCUSSION OF TILT APPLICATIONS AND RESOLUTION

Tilt Applications: One of the most popular applications of the MEMSIC accelerometer product line is in tilt/inclination measurement. An accelerometer uses the force of gravity as an input to determine the inclination angle of an object.

A MEMSIC accelerometer is most sensitive to changes in position, or tilt, when the accelerometer’s sensitive axis is perpendicular to the force of gravity, or parallel to the Earth’s surface. Similarly, when the accelerometer’s axis is parallel to the force of gravity (perpendicular to the Earth’s surface), it is least sensitive to changes in tilt.

Table 1 and Figure 2 help illustrate the output changes in the X- and Y-axes as the unit is tilted from +90° to 0°. Notice that when one axis has a small change in output per degree of tilt (in mg), the second axis has a large change in output per degree of tilt. The complementary nature of these two signals permits low cost accurate tilt sensing to be achieved with the MEMSIC device (reference application note AN-00MX-007).

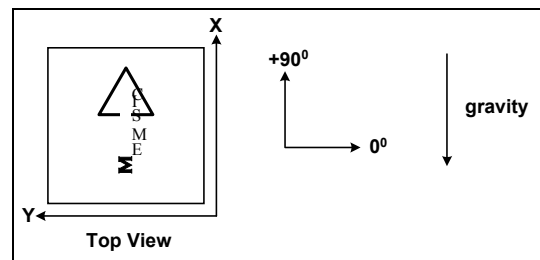

Figure 2: Accelerometer Position Relative to Gravity

X-Axis Orientation To Earth’s Surface (deg.)	X-Axis		Y-Axis	
	X Output (g)	Change per deg. of tilt (mg)	Y Output (g)	Change per deg. of tilt (mg)
90	1.000	0.15	0.000	17.45
85	0.996	1.37	0.087	17.37
80	0.985	2.88	0.174	17.16
70	0.940	5.86	0.342	16.35
60	0.866	8.59	0.500	15.04
45	0.707	12.23	0.707	12.23
30	0.500	15.04	0.866	8.59
20	0.342	16.35	0.940	5.86
10	0.174	17.16	0.985	2.88
5	0.087	17.37	0.996	1.37
0	0.000	17.45	1.000	0.15

Table 1: Changes in Tilt for X- and Y-Axes

Resolution: The accelerometer resolution is limited by noise. The output noise will vary with the measurement bandwidth. With the reduction of the bandwidth, by applying an external low pass filter, the output noise drops. Reduction of bandwidth will improve the signal to noise ratio and the resolution. The output noise scales directly with the square root of the measurement bandwidth. The maximum amplitude of the noise, its peak-to-peak value, approximately defines the worst case resolution of the measurement. With a simple RC low pass filter, the rms noise is calculated as follows:

$$\text{Noise (mg rms)} = \text{Noise(mg}/\sqrt{\text{Hz}}) * \sqrt{(\text{Bandwidth(Hz)} * 1.6)}$$

The peak-to-peak noise is approximately equal to 6.6 times the rms value (for an average uncertainty of 0.1%).

DIGITAL INTERFACE

The MXD2020GL/HL/ML/NL is easily interfaced with low cost microcontrollers. For the digital output accelerometer, one digital input port is required to read one accelerometer output. For the analog output accelerometer, many low cost microcontrollers are available today that feature integrated A/D (analog to digital converters) with resolutions ranging from 8 to 12 bits.

In many applications the microcontroller provides an effective approach for the temperature compensation of the sensitivity and the zero g offset. Specific code set, reference designs, and applications notes are available from the factory. The following parameters must be considered in a digital interface:

Resolution: smallest detectable change in input acceleration
Bandwidth: detectable accelerations in a given period of time

Acquisition Time: the duration of the measurement of the acceleration signal

DUTY CYCLE DEFINITION

The MXD2020GL/HL/ML/NL has two PWM duty cycle outputs (x,y). The acceleration is proportional to the ratio T1/T2. The zero g output is set to 50% duty cycle and the sensitivity scale factor is set to 20% duty cycle change per g. These nominal values are affected by the initial tolerance of the device including zero g offset error and sensitivity error. This device is offered from the factory programmed to either a 10ms period (100 Hz) or a 2.5ms period (400Hz).

T1 Length of the “on” portion of the cycle.
T2 (Period) Length of the total cycle.
Duty Cycle Ratio of the “On” time (T1) of the cycle to the total cycle (T2). Defined as T1/T2.

Pulse width Time period of the “on” pulse. Defined as T1.

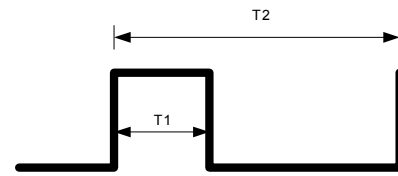

$$A (g) = (T1/T2 - 0.5)/20\%$$

0g = 50% Duty Cycle
T2= 2.5ms or 10ms (factory programmable)

Figure 3: Typical output Duty Cycle

CHOOSING T2 AND COUNTER FREQUENCY DESIGN TRADE-OFFS

The noise level is one determinant of accelerometer resolution. The second relates to the measurement resolution of the counter when decoding the duty cycle output. The actual resolution of the acceleration signal is limited by the time resolution of the counting devices used to decode the duty cycle. The faster the counter clock, the higher the resolution of the duty cycle and the shorter the T2 period can be for a given resolution. Table 2 shows some of the trade-offs. It is important to note that this is the resolution due to the microprocessors’ counter. It is probable that the accelerometer’s noise floor may set the lower limit on the resolution.

T2 (ms)	MEMSIC Sample Rate	Counter-Clock Rate (MHz)	Counts Per T2 Cycle	Counts per g	Resolution (mg)
2.5	400	2.0	5000	1000	1.0
2.5	400	1.0	2500	500	2.0
2.5	400	0.5	1250	250	4.0
10.0	100	2.0	20000	4000	0.25
10.0	100	1.0	10000	2000	0.5
10.0	100	0.5	5000	1000	1.0

Table 2: Trade-Offs Between Microcontroller Counter Rate and T2 Period.

USING THE ACCELEROMETER IN VERY LOW POWER APPLICATIONS (BATTERY OPERATION)

In applications with power limitations, power cycling can be used to extend the battery operating life. One important consideration when power cycling is that the accelerometer turn on time limits the frequency bandwidth of the accelerations to be measured. For example, operating at 3.0V the turn on time is 40mS. To double the operating time, a particular application may cycle power ON for 40mS, then OFF for 40mS, resulting in a measurement period of 80mS, or a frequency of 12.5Hz. With a frequency of measurements of 12.5Hz, accelerations changes as high as 6.25Hz can be detected. Power cycling can be used effectively in many inclinometry applications, where inclination changes can be slow and infrequent.

CONVERTING THE DIGITAL OUTPUT TO AN ANALOG OUTPUT

The PWM output can be easily converted into an analog output by integration. A simple RC filter can do the conversion. Note that the impedance of the circuit following the integrator must be much higher than the impedance of the RC filter. Reference figure 4 for an example.

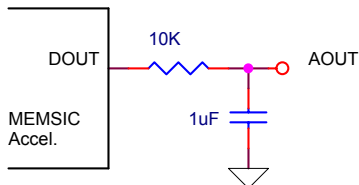

Figure 4: Converting the digital output to an analog voltage

POWER SUPPLY NOISE REJECTION

Two capacitors and a resistor are recommended for best rejection of power supply noise (reference Figure 5 below). The capacitors should be located as close as possible to the device supply pins (V_{DA} , V_{DD}). The capacitor lead length should be as short as possible, and surface mount capacitors are preferred. For typical applications, capacitors C1 and C2 can be ceramic 0.1 μF , and the resistor R can be 10 Ω . In 5V applications where power consumption is not a concern, maximum supply noise rejection can be obtained by significantly increasing the values of C1, C2 and R. For example, $C1 = C2 = 0.47 \mu\text{F}$ and $R = 270 \Omega$ will virtually eliminate power supply noise effects.

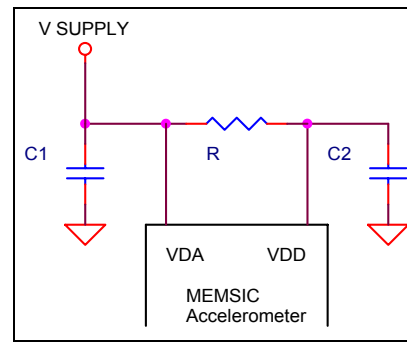

Figure 5: Power Supply Noise Rejection

PCB LAYOUT AND FABRICATION SUGGESTIONS

1. The Sck pin should be grounded to minimize noise.
2. Liberal use of ceramic bypass capacitors is recommended.
3. Robust low inductance ground wiring should be used.
4. Care should be taken to ensure there is “thermal symmetry” on the PCB immediately surrounding the MEMSIC device and that there is no significant heat source nearby.
5. A metal ground plane should be added directly beneath the MEMSIC device. The size of the plane should be similar to the MEMSIC device’s footprint and be as thick as possible.
6. Vias can be added symmetrically around the ground plane. Vias increase thermal isolation of the device from the rest of the PCB.

LCC-8 PACKAGE DRAWING

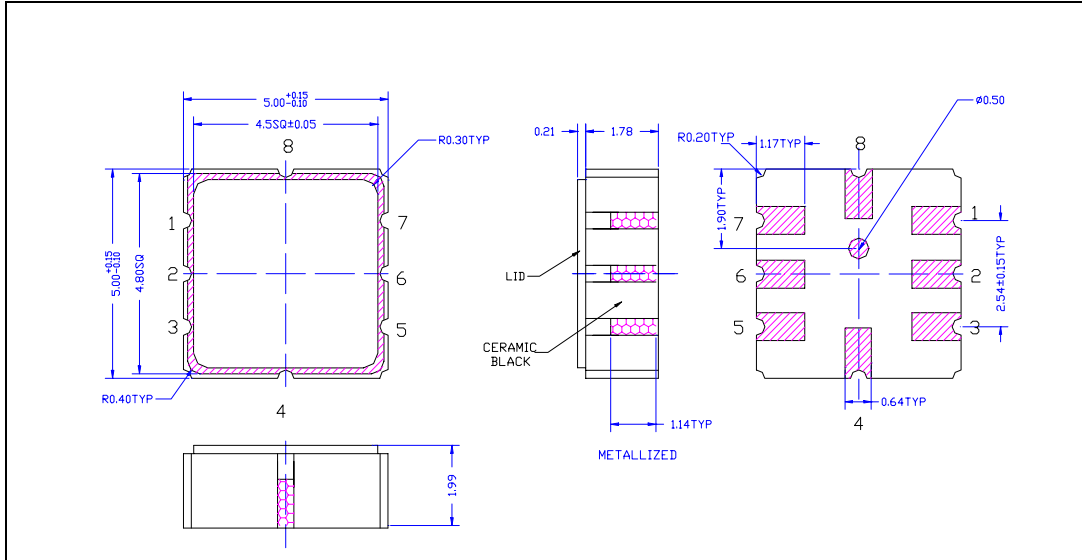

Fig 6: Hermetically Sealed Package Outline