



MXD202 (DIGITAL)

Low Cost, 2.0g, Dual Axis Accelerometer with Digital Outputs

General Description

The MXD202 is a very low cost dual-axis acceleration sensor on a monolithic IC. With no moving parts, the device is extremely reliable and is manufactured on a submicron CMOS process enabling small geometries and small die size, resulting in low overall cost and high functionality. The MXD202 is primarily designed for applications requiring high performance and where overall system cost is a driving factor in component selection. The MXD202 measures acceleration with a full-scale range of up to $\pm 2.0g$ and produces a PWM digital signal output. Sensor is shipped with a duty cycle period of 10 milli-Seconds (100 Hz). Special order sensors are available with a duty cycle period of 2.5 milli-Seconds (400 Hz). Typical noise floor is .01% Duty Cycle/Hz, allowing signals below 1.0 milli-g to be resolved. Frequency response extends to 40 Hz. The frequency response can be extended to 160 Hz with the implementation of a simple external circuit.

The MXD202 is a dc accelerometer with the capability to measure both ac acceleration, (typical of vibration) or dc accelerations, (such as inertial force or constant, gravity-induced accelerations).

The MXD202 offers digital output signals which duty cycles (ratio of pulse width to period) are proportional to the acceleration in each of the axes of sensitivity. The outputs can be measured directly with a microprocessor counter, eliminating the need for A/D converter or glue logic. The output duty cycle is programmable over a wide range of sensitivity. MXD202 offers a calibrated temperature sensor output with a positive temperature coefficient of 5.0 mV/°C. This device can be temperature compensated easily. The change in sensitivity over the temperature range -40°C to 125°C is predictable and follows the physical gas laws. The following equation can be used to predict the sensitivity at any given temperature: $S_{IN} \times (T_{IN})^{2.67} = S_{FIN} \times (T_{FIN})^{2.67}$ (Temperature in °K) See Application Note (AN-00MX-001).

The MXD202 is available in a metal can (TO-100) or a surface mount (LCC); both are hermetic and are specified over the temperature range -40°C to 125°C.

Applications

- **Automotive** - Vehicle Security/Active Suspension/ABS/HED Angle Control
- **Security** - Gas Line/Elevator/Fatigue Sensing
- **Office Automation Equipment** - Computer Peripherals/Disk Drives/PDA's/Mouse Smart Pens/Cell Phones/Printer Head Acceleration Sensor
- **Gaming** - Joystick/RF Interface/Menu Selection
- **White Goods** - Spin Control/Cooktop Vibration

Block Diagram of MX20XX

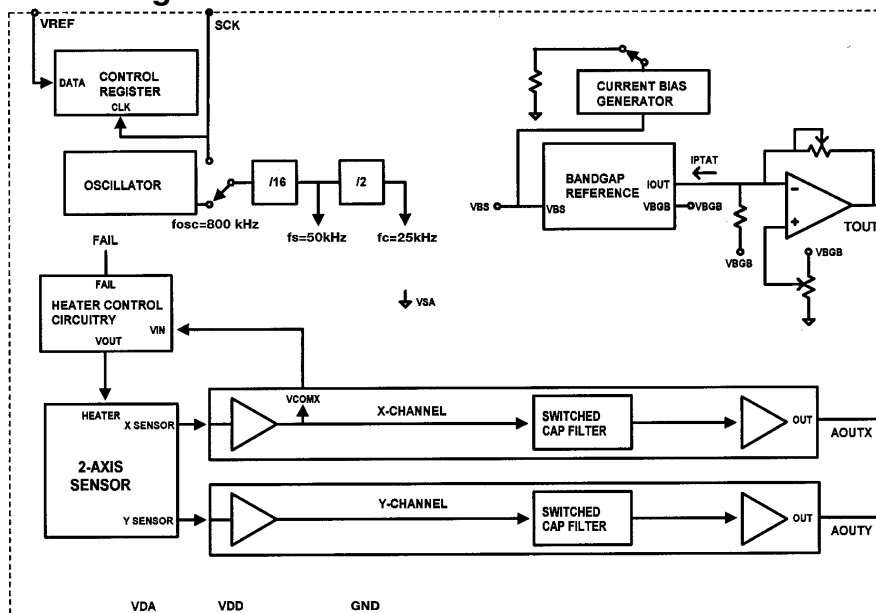

Features

- Dual axis acceleration outputs
- Digital outputs
- 1.0 mg Resolution in 1Hz bandwidth
- 40 Hz Bandwidth expandable to 160 Hz
- Quiescent Supply Voltage: 3.5 mA
- 0g output 50% duty cycle
- 50,000g shock survival
- 2.70V to 5.25V Single Supply
- On-chip mixed signal processing
- Continuous sensors self test
- Temperature sensor output (Tout) 5mV/°K
- Packaged in 8 pin LCC SMD or 10 pin TO-100 THRU-HOLE
- Hermetically sealed packaging
- Reference voltage (VREF) 2.50V

Information furnished by MEMSIC is believed to be accurate and reliable. However, no responsibility is assumed by MEMSIC for its use, nor for any infringements of patents or other rights of third parties which may result from its use. No license is granted by implications or otherwise under any patent or patent rights of MEMSIC.

Technical information.
Subject to change without notice.

MXD202 DIGITAL Data Sheet K 8/1/01

©MEMSIC, Inc. 2000.
100 Burtt Road, Andover, MA 01810
Tel: 978.623.8188 • Fax: 978.623.9945
www.memsic.com



Data Sheet

MXD202

Page 2 of 8

MXD202 SPECIFICATIONS Digital Electrical Characteristics

Measurements @ 25°C Acceleration = 0g unless otherwise noted
VDD, VDA = 5.0V unless otherwise specified

Parameter	Conditions	MEMSIC MXD202			Units
		Min	Typ	Max	
SENSOR Measurement Range ¹ Nonlinearity Alignment Error ²	Each axis	+/- 2.0			g % of FS degrees
	Best Fit Straight Line		2 +/- 1.0	+/- 2.5	
SENSITIVITY Output in Duty Cycle per g Temperature Changes ⁸	Each axis		10		% Duty Cycle /g
	Delta from 25°C per formula $S_{IN} X (T_{IN})^{2.67} = S_{FIN} X (T_{FIN})^{2.67}$				
Cross-Axis Sensitivity ³	X sensor to Y sensor		+/- 2		%
ZERO g BIAS LEVEL	Each axis	48	50	52	% Duty Cycle
0g Offset vs. Temperature ⁴			2.0		mg/°C
NOISE PERFORMANCE Noise Density ⁵ % Duty Cycle	@ +25°C		0.010	0.011	% Duty Cycle /√Hz
FREQUENCY RESPONSE 3 dB Bandwidth 3 dB Bandwidth ⁷			40		Hz Hz
			160		
Tout Voltage Temp sensor sensitivity	25°C	1.23	1.25	1.27 5	V mV/°K
V REFERENCE ⁹	25°C	2.4	2.5	2.6	V
SELF TEST Voltage Delta at outputs @5V Supply @2.7V Supply	Continuous, Output rails with failure			5.0 2.7	V V
X, Y OUTPUTS Rise/Fall Time	Digital signal of 100Hz	90	100	110	nsec
POWER SUPPLY Operating Voltage Range Specified Performance Quiescent Supply Current @ 5V Quiescent Supply Current @ 2.7V Turn-On Time ⁶		2.7		5.25	V
			3.0	3.5	mA
			4.0	4.5	mA
			200	400	ms
TEMPERATURE RANGE Operating Range		-40		125	°C

NOTES

- ¹Guarantee by measurements of initial offset and sensitivity.
- ²Alignment error is specified as the angle between the true and indicated axis of sensitivity.
- ³Cross-axis sensitivity is the algebraic sum of the alignment and the inherent sensitivity errors.
- ⁴Specification refers to the maximum change in parameter from its initial value at 25°C to its worst case value at T_{min} to T_{max} of the specified temperature range.
- ⁵Noise density (% Duty Cycle/√Hz) is the average noise at any frequency in the bandwidth of the device.
- ⁶The voltage is required to ramp full scale before making a measurement.
- ⁷**Note: Frequency compensating circuit will achieve 160 Hz operations.**
- ⁸Defined as the output change from ambient to maximum temperature or minimum. Output change expressed in % change of duty cycle.
- ⁹For more details refer to Application Note (AN-00MX-001).
- All min and max specifications are subject to change without notification.

Information furnished by MEMSIC is believed to be accurate and reliable. However, no responsibility is assumed by MEMSIC for its use, nor for any infringements of patents or other rights of third parties which may result from its use. No license is granted by implications or otherwise under any patent or patent rights of MEMSIC.

Technical information.
Subject to change without notice.

MXD202 DIGITAL Data Sheet K 8/1/01

©MEMSIC, Inc. 2000.
100 Burt Road, Andover, MA 01810
Tel: 978.623.8188 • Fax: 978.623.9945
www.memsic.com



Data Sheet

MXD202

Page 3 of 8

ABSOLUTE MAXIMUM RATINGS*

Symbol	Parameter	Rating	Units
VDD	Supply Voltage to Ground Potential	-0.5 to 7.0	Volts
T _{STG}	Storage Temperature	-65 to +150	Deg C
	Acceleration	50,000	g

*Stresses above those listed under "Absolute Maximum Ratings" may cause permanent damage to the device. These are stress ratings only; the functional operation of this device at these or any other conditions above those indicated in the operational sections of this specification is not implied. Exposure to absolute maximum rating conditions for extended periods may affect device reliability.

PACKAGE CHARACTERISTICS

Package	ThetaJA	ThetaJC	Device Weight
TO-100	150°C/W	25°C/W	0.04 oz
LCC-8	110°C/W	22°C/W	0.02 oz

ORDERING GUIDE

Model	Package Style
MXD202AC	TO-100 Metal Can
MXD202AL	LCC-8 SMD *

* LCC parts are shipped in tape and reel packaging.

NOTE

Drops onto hard surfaces can cause shocks of greater than 50,000g and exceed the absolute maximum rating of the device. Care should be exercised in handling to avoid damage.

CAUTION

ESD (electrostatic discharge) sensitive device.

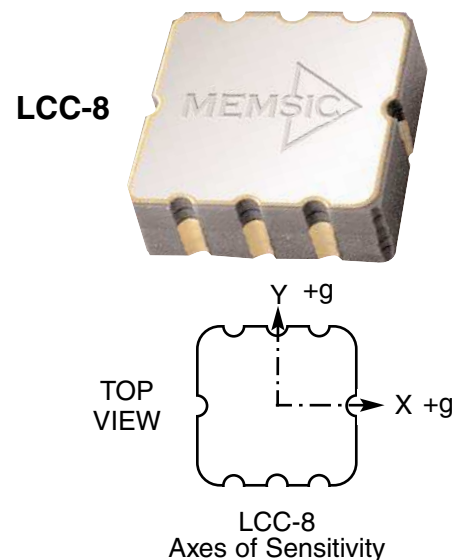
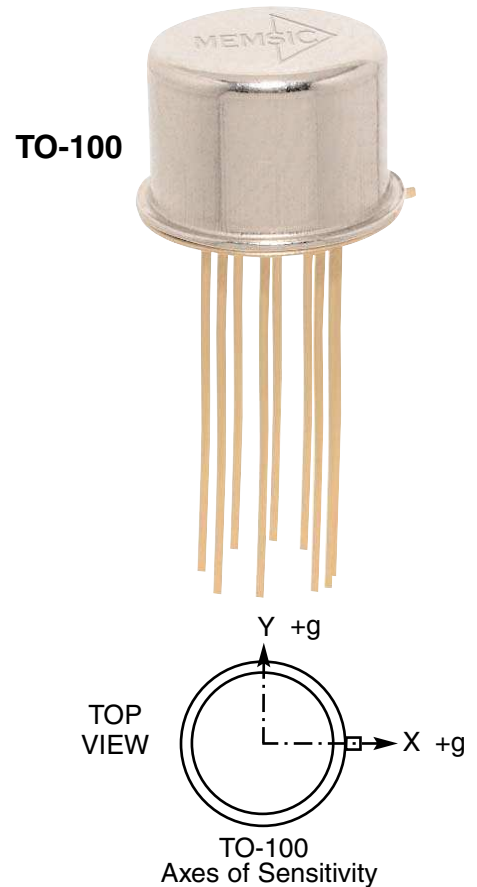

MXD202 DIGITAL Data Sheet K 8/1/01

©MEMSIC, Inc. 2000.
100 Burt Road, Andover, MA 01810
Tel: 978.623.8188 • Fax: 978.623.9945
www.memsic.com

Pin Function Descriptions TOP-100 and LCC-8

PIN DESCRIPTION: TO-100 Package

Pin	Name	Description
1	VDD	Digital Supply Voltage
2	TOUT	Temperature
3	AOUTY	Acceleration Signal
4	GND	Ground
5	n/c	no connection
6	VDA	Analog Supply Voltage
7	AOUTX	Acceleration Signal
8	VREF	2.50V Reference Voltage
* 9	SCK	Serial Clock
10	n/c	no connection

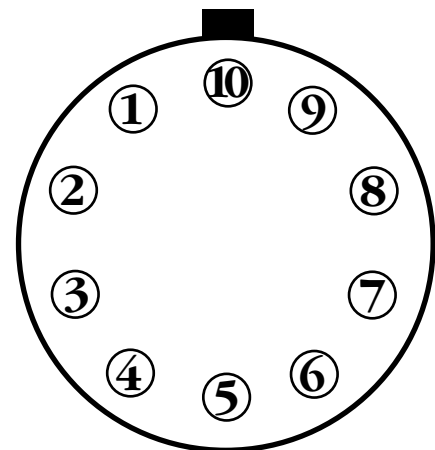

Top View

PIN DESCRIPTION: LCC-8 Package

Pin	Name	Description
1	TOUT	Temperature
2	AOUTY	Acceleration Signal
3	GND	Ground
4	VDA	Analog Supply Voltage
5	AOUTX	Acceleration Signal
6	VREF	2.50V Reference Voltage
* 7	SCK	Serial Clock
8	VDD	Digital Supply Voltage

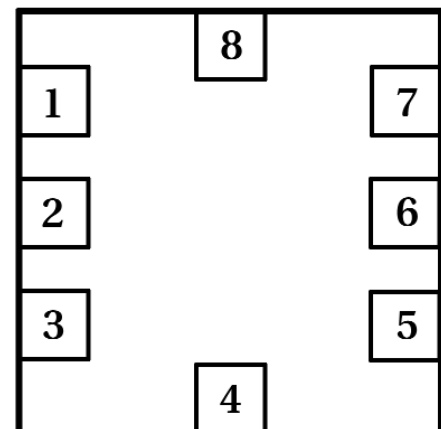

Top View

* Optional external clock factory programmed per customer request



Pin Definition

VDD - This is the digital power supply input for the MX20XX. The DC voltage should be between 2.70 and 5.25 volts.

VDA - This is the analog power supply input for the MX20XX. VDA should always be connected to VDD.

GND - This is the ground pin for the MX20XX.

AOUTX - This pin is the output of the x-acceleration sensor.

AOUTY - This pin is the output of the y-acceleration sensor.

TOUT - This pin is the buffered output of the temperature sensor. The voltage at TOUT is an indication of the die temperature. This voltage can be measured and used to compensate out the temperature dependence of accelerometer sensitivity.

SCK - Standard product is delivered with an Internal Clock option. Ground this pin when operating with the Internal Clock. The External Clock must be ordered special from the factory.

VREF - A reference voltage is output from this pin.



Data Sheet

MXD202

Page 6 of 8

Package Outline LCC-8 mm (in)

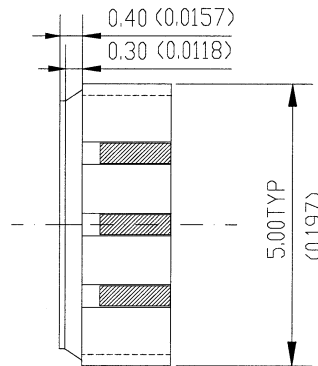
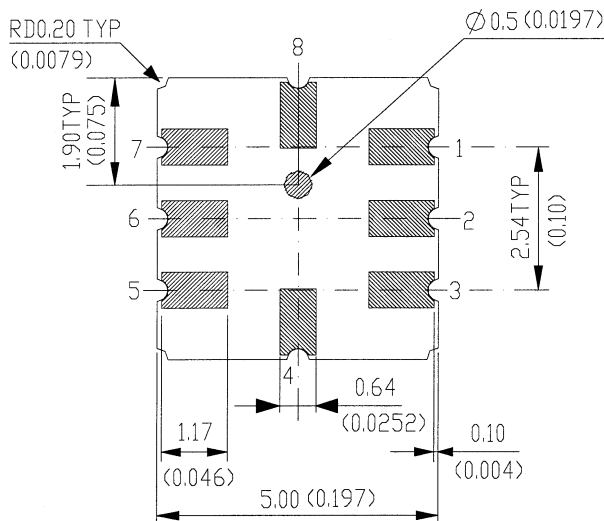
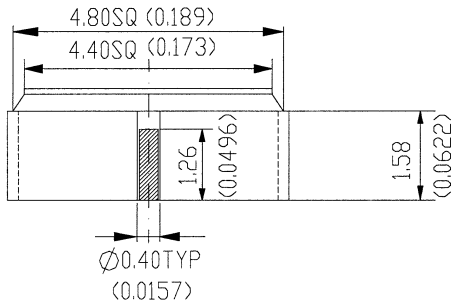
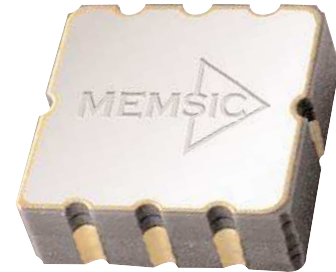

Information furnished by MEMSIC is believed to be accurate and reliable. However, no responsibility is assumed by MEMSIC for its use, nor for any infringements of patents or other rights of third parties which may result from its use. No license is granted by implications or otherwise under any patent or patent rights of MEMSIC.

Preliminary technical information.
Subject to change without notice.

MXD202 DIGITAL Data Sheet K 8/1/01

©MEMSIC, Inc. 2000.
100 Burt Road, Andover, MA 01810
Tel: 978.623.8188 • Fax: 978.623.9945
www.memsic.com



Data Sheet

MXD202

Page 7 of 8

Package Outline T0-100 mm (in)

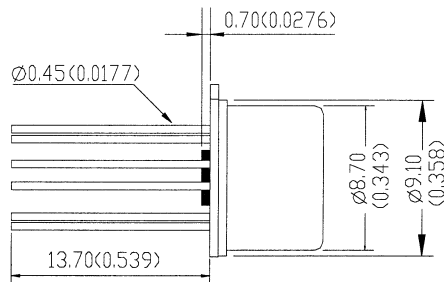
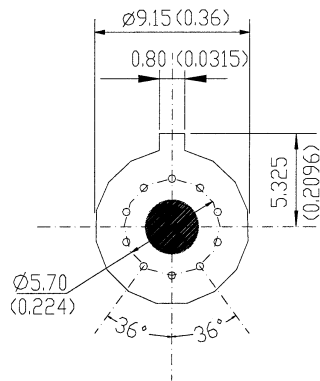
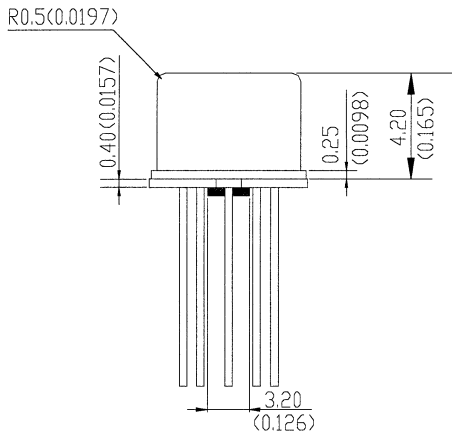

Information furnished by MEMSIC is believed to be accurate and reliable. However, no responsibility is assumed by MEMSIC for its use, nor for any infringements of patents or other rights of third parties which may result from its use. No license is granted by implications or otherwise under any patent or patent rights of MEMSIC.

Preliminary technical information.
Subject to change without notice.

MXD202 DIGITAL Data Sheet K 8/1/01

©MEMSIC, Inc. 2000.
100 Burt Road, Andover, MA 01810
Tel: 978.623.8188 • Fax: 978.623.9945
www.memsic.com

Printed Circuit Board Layout and Fabrication Requirements

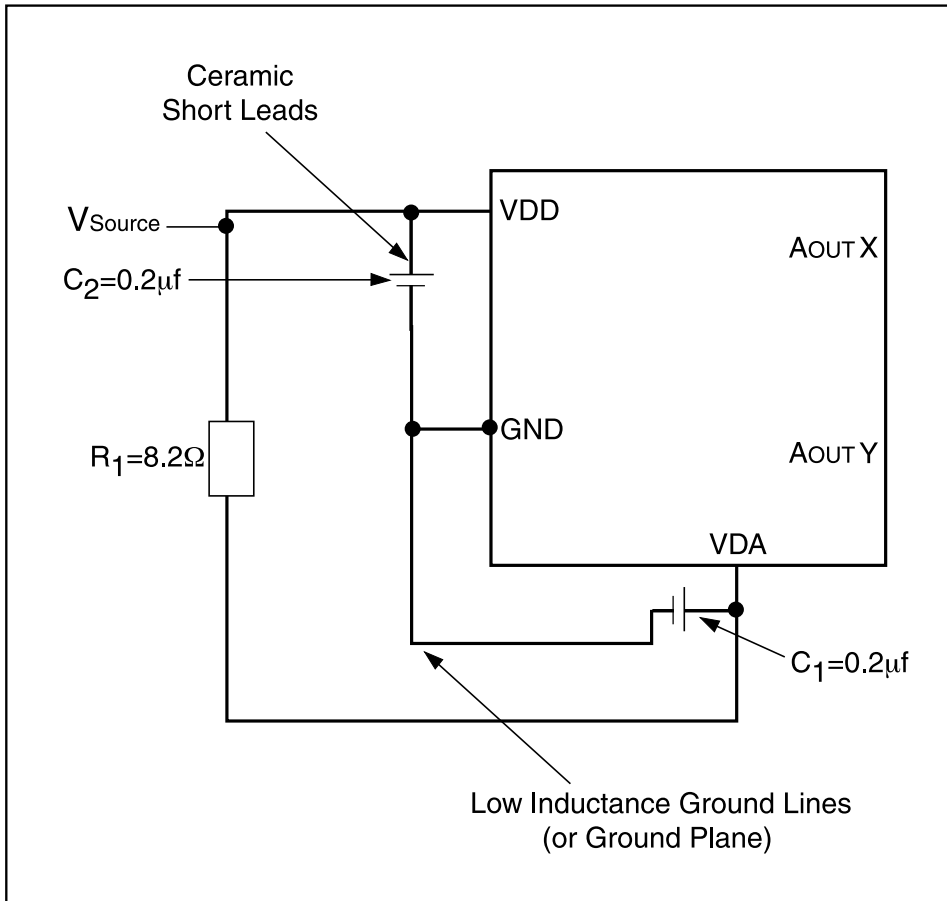

NOTES

1. Use robust low inductance ground wiring
2. Liberal use of ceramic bypass capacitors
3. The Capacitors should be located as close as possible to the device supply pins (VDA, VDD).
4. The capacitor lead length should be as short as possible. Surface mount capacitors are preferred.

Information furnished by MEMSIC is believed to be accurate and reliable. However, no responsibility is assumed by MEMSIC for its use, nor for any infringements of patents or other rights of third parties which may result from its use. No license is granted by implications or otherwise under any patent or patent rights of MEMSIC.

Technical information.
Subject to change without notice.

MXD202 DIGITAL Data Sheet K 8/1/01

©MEMSIC, Inc. 2000.
100 Burt Road, Andover, MA 01810
Tel: 978.623.8188 • Fax: 978.623.9945
www.memsic.com