

FEATURES

- two outputs, adjustable from 0 to 1100 mVp-p into 75 Ω loads
- nominal 600 ps rise and fall times
- accepts SMPTE and standard ECL input levels
- operates from a single +5 or -5 volt supply
- on-chip DC restoration for low jitter
- 170 mW power dissipation
- interfaces with **GENLINX™ GS9002, GS9004A, GS9005A and GS9015A**

APPLICATIONS

- SMPTE 259M Serial Digital Systems (4:2:2 & 4fsc)
- Other Serial Digital Video Interfaces - 360 Mb/s
- General purpose high speed driver applications

PIN CONNECTIONS

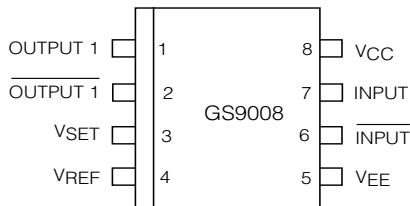

ORDERING INFORMATION

Part Number	Package Type	Temperature Range
GS9008 - CKA	8 Pin SOIC	0° to 70°C

DEVICE DESCRIPTION

The **GENLINX™** GS9008 is a bipolar integrated circuit designed to drive two 75 Ω co-axial cables at data rates exceeding 400 Mb/s. It directly interfaces with other **GENLINX™** devices and can also be used as a general purpose high speed cable driver.

While there are no plans to discontinue the GS9008, Gennum has developed a successor product with improved features and performance called the GS9028. The GS9028 is recommended for new designs.

The differential inputs are AC-coupled and internally DC-restored which allows correct passage of pathological check codes associated with the serial digital standards. Even though the inputs are AC coupled, static protection diodes at each input restrict the DC differential so that if the driving source uses the opposite polarity power supply, external DC blocking capacitors must be used.

Correctly terminated output signal levels are adjustable from as low as 0 mV to as high as 1100 mV with little change in other performance parameters. Performance is guaranteed for output levels between 600 mV and 1000 mV. The gain of the output stages is varied by adjusting the V_{SET} voltage with respect to an internal band gap reference voltage V_{REF} .

The GS9008 is packaged in an 8 pin SOIC, and operates from a single +5 or -5 volt supply consuming typically only 170 mW of power.

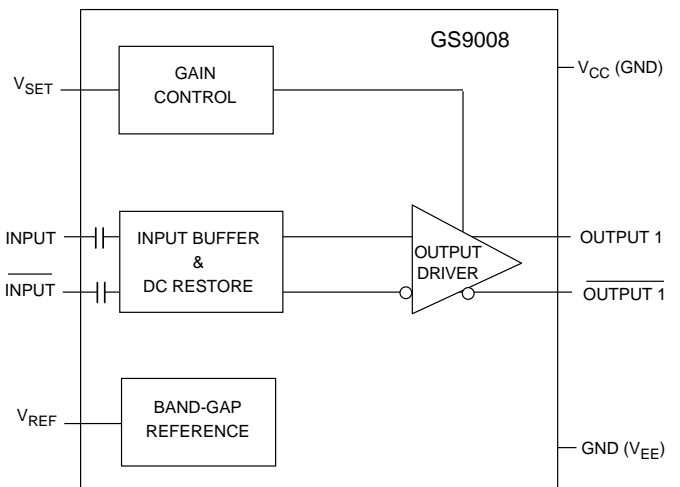

Patent No. 5,426,389.

FUNCTIONAL BLOCK DIAGRAM

ABSOLUTE MAXIMUM RATINGS

PARAMETER	VALUE
Supply Voltage (V_S)	5.5 V
Input Voltage Range (any input)	$V_S - 0.5$ V
Power Dissipation	300 mW
Operating Temperature Range	$0^\circ\text{C} \leq T_A \leq 70^\circ\text{C}$
Storage Temperature Range	$-65^\circ\text{C} \leq T_S \leq 150^\circ\text{C}$
Lead Temperature (soldering, 10 sec)	260°C

GS9008 CABLE DRIVER - DC ELECTRICAL CHARACTERISTICS

Conditions: $V_S = 5\text{V}$, $T_A = 0^\circ\text{C}$ to 70°C , $R_L = 150\ \Omega$ to GND and $144\ \Omega$ AC coupled unless otherwise shown

PARAMETER	SYMBOL	CONDITIONS	MIN	TYP	MAX	UNITS	
Supply Voltage	V_S		4.5	5.0	5.5	volts	
Power Consumption	P_D	2 x 150 Ω Loads DC	-	170	190	mW	
Supply Current	I_{S1}	1% Accuracy, $T_A = 25^\circ\text{C}$ $V_{SET} = (0.667) V_{REF}$	-	62	67	mA	
Supply Current	I_{S2}	DC No Loads, $T_A = 25^\circ\text{C}$	-	16	20	mA	
Reference Voltage	V_{REF}	10 k Ω to ground	-	1.2	-	volts	

GS9008 CABLE DRIVER - AC ELECTRICAL CHARACTERISTICS

Conditions: $V_S = 5\text{V}$, $T_A = 0^\circ\text{C}$ to 70°C , $R_L = 150\ \Omega$ to GND and $144\ \Omega$ AC coupled unless otherwise shown

PARAMETER	SYMBOL	CONDITIONS	MIN	TYP	MAX	UNITS	NOTES
Input Signal Amplitude	V_{IN}		700	800	1000	mVp-p	
Input Signal Rise/Fall Times	t_R, t_F		-	-	750	ps	
Output Amplitudes across 75 Ω Load (See Note 1)	V_{OUT}	$V_{SET} = (0.5) V_{REF}$	540	600	660	mVp-p	Notes 1 & 2
		$V_{SET} = (0.667) V_{REF}$	720	800	880	mVp-p	Notes 1 & 2
		$V_{SET} = (0.833) V_{REF}$	900	1000	1100	mVp-p	Notes 1 & 2
Output Amplitude Temperature Coefficient (See Note 2)	T_C	$V_{SET} = (0.5) V_{REF}$	-	25	100	ppm/ $^\circ\text{C}$	
		$V_{SET} = (0.667) V_{REF}$	-	-12	80	ppm/ $^\circ\text{C}$	
		$V_{SET} = (0.833) V_{REF}$	-	-45	80	ppm/ $^\circ\text{C}$	
Output Rise/Fall Times (20% to 80%)	t_R, t_F	$V_{SET} = (0.5) V_{REF}$	400	630	800	ps	
		$V_{SET} = (0.667) V_{REF}$	400	575	800	ps	
		$V_{SET} = (0.833) V_{REF}$	400	530	800	ps	
Output Overshoot		$t_R = t_F = 600$ ps	-	0	-	%	See Fig. 3
Jitter	t_J	at 270 Mb/s	-	-	± 25	ps	
Propagation Delay	t_P		-	1	-	ns	

NOTE 1. V_{OUT} is measured across a correctly terminated load, back matched to the device. The peak to peak voltage of the device itself is $2 \times V_{OUT}$.

2. V_{OUT} is proportional to V_{SET} and V_{SET} may be an external low impedance, high stability supply. In this case the amplitude temperature coefficient will not be guaranteed.

INPUT / OUTPUT CIRCUITS

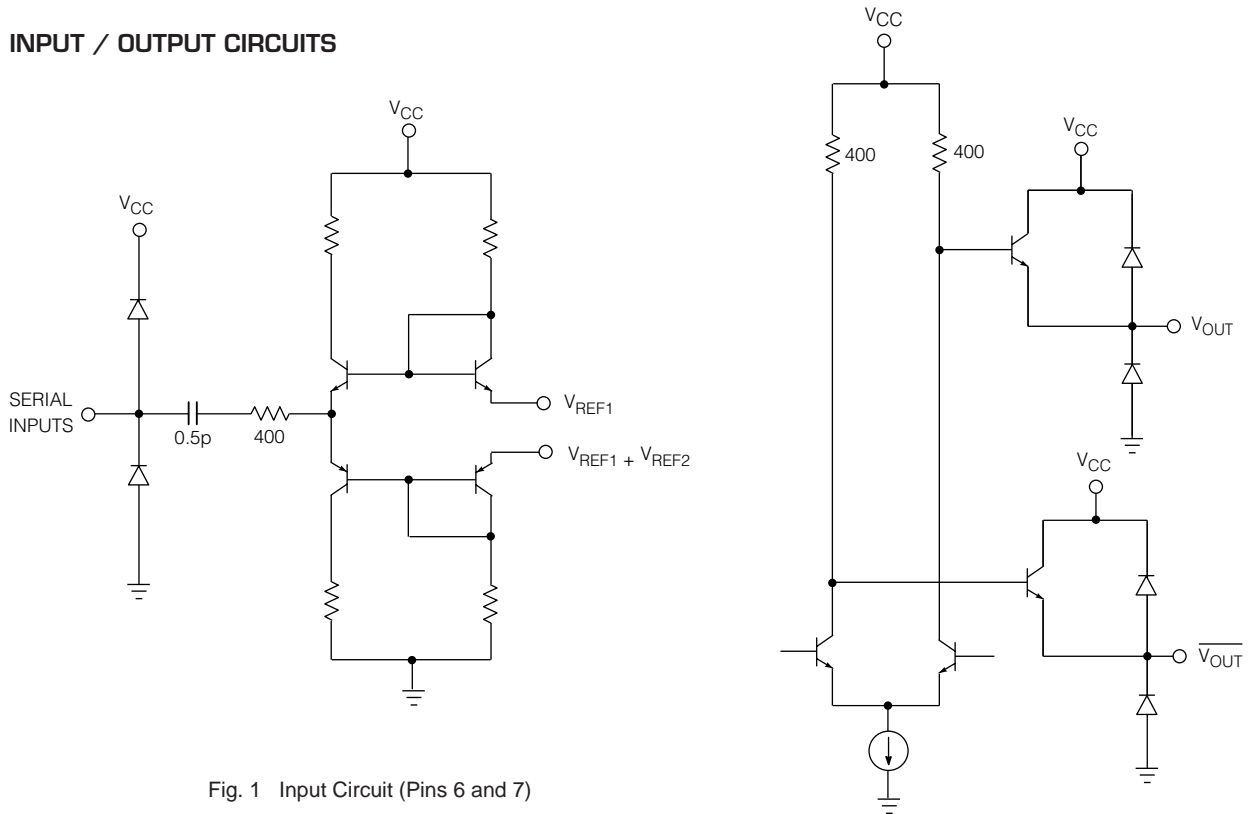

Fig. 1 Input Circuit (Pins 6 and 7)

Fig. 2 Output Circuit (Pins 1 and 2)

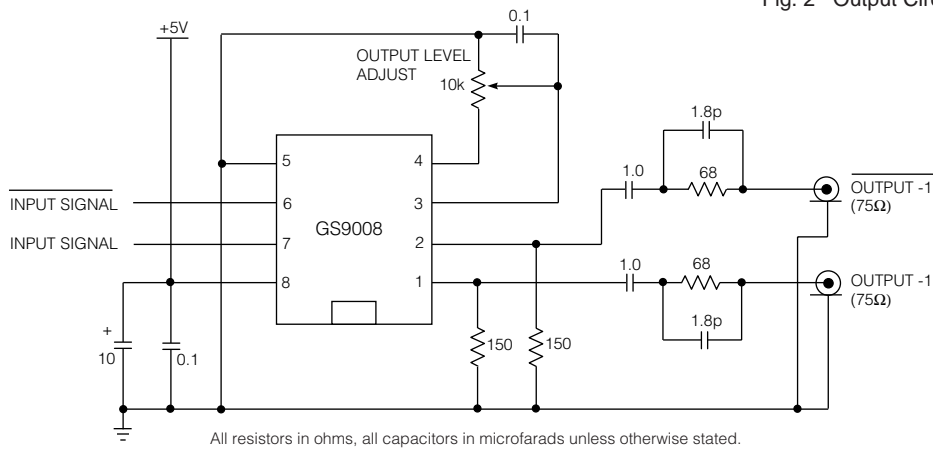

Fig. 3 Typical Application Circuit

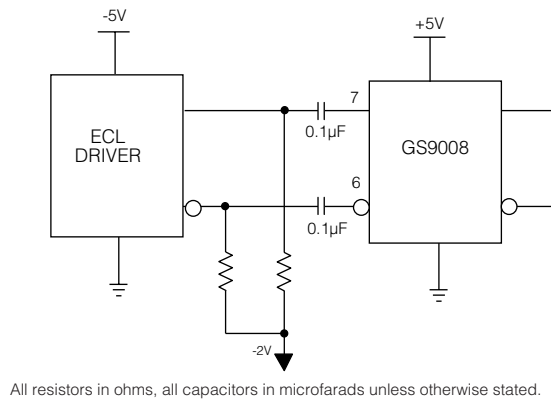

Fig. 4 Split Supply Interfacing

CAUTION
ELECTROSTATIC
SENSITIVE DEVICES
DO NOT OPEN PACKAGES OR HANDLE
EXCEPT AT A STATIC-FREE WORKSTATION



DOCUMENT IDENTIFICATION: DATA SHEET

The product is in production. Gennum reserves the right to make changes at any time to improve reliability, function or design, in order to provide the best product possible.

REVISION NOTES:

New information added to Device Description

GENNUM CORPORATION

MAILING ADDRESS:

P.O. Box 489, Str. A, Burlington, Ontario, Canada L7R 3Y3
Tel. +1 (905) 632-2996 Fax +1 (905) 632-2814

SHIPPING ADDRESS:

970 Fraser Drive, Burlington, Ontario, Canada L7L 5P5

GENNUM JAPAN CORPORATION

C-101, Miyamae Village, 2-10-42 Miyamae, Sugunami-ku, Tokyo 168-0081, Japan

Tel. +81 (3) 3334-7700 Fax: +81 (3) 3247-8839

GENNUM UK LIMITED

Centaur House, Ancells Business Park, Ancells Road, Fleet, Hampshire, UK GU13 8UJ

Tel. +44 (1252) 761 039 Fax +44 (1252) 761 114

Gennum Corporation assumes no responsibility for the use of any circuits described herein and makes no representations that they are free from patent infringement.

© Copyright March 1993 Gennum Corporation. All rights reserved.

Printed in Canada.