

Ultra small size high selectivity type ceramic filter for communication use.

FEATURES

- Ultra small size
- 6.3 mm profile
- Broad bandwidth
- RoHS Compliant (Note 7 exemption)
- 6 elements

OPERATING CONDITIONS/ELECTRICAL CHARACTERISTICS

PART NUMBER	CENTER FREQUENCY (KHz)	INSERTION LOSS (dB) MAX.	PASS BAND RIPPLE (dB) MAX.	6 dB BANDWIDTH (KHz) MIN.	50 dB BANDWIDTH (dB) MAX.	STOP BAND ATT. ±100KHZ (dB) MIN.	INPUT / OUTPUT IMPEDANCE (Ω)
LTM450BW	450 ±2.0	4	2	±15	±30	45	1500
LTM450CW	450 ±2.0	4	2	±12.5	±24	45	1500
LTM450DW	450 ±1.5	4	2	±10	±20	45	1500
LTM450EW	450 ±1.5	6	2	±7.5	±15	45	1500
LTM450FW	450 ±1.5	6	2	±6	±12.5	45	2000
LTM450GW	450 ±1.5	6	2	±4.5	±10	45	2000
LTM450HW	450 ±1.0	6	2	±3	±9	55	2000
LTM450IW	450 ±1.0	6	2	±2	±7.5	55	2000
LTM450HTW	450 ±1.0	6	2	±3	±9	60	2000
LTM450ITW	450 ±1.0	6	2	±2	±7.5	60	2000

PACKAGE DIMENSIONS (mm)

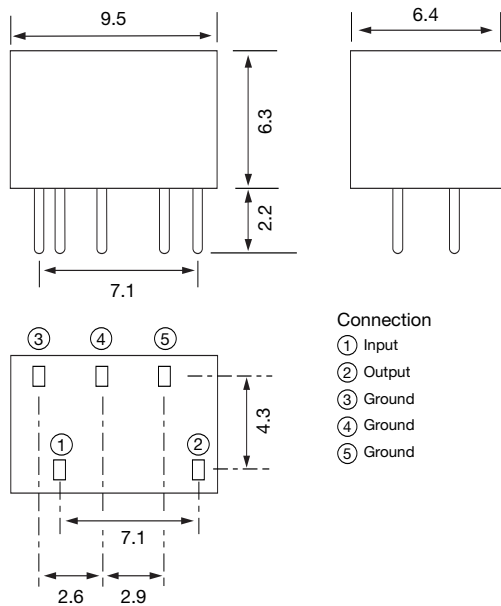

Figure 1) LTM450W – Front, Side and Bottom views

Note: To avoid potential problems, connect the output to an IF amplifier through a DC cut capacitor.
Avoid applying a direct current to output end of the ceramic filters (between ⑤ and ②③④).

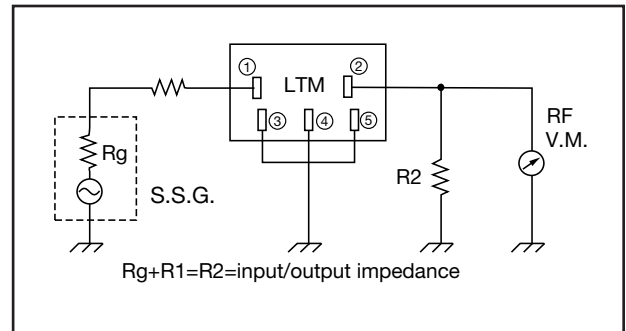

Figure 2) LTM450W – Measuring Circuit

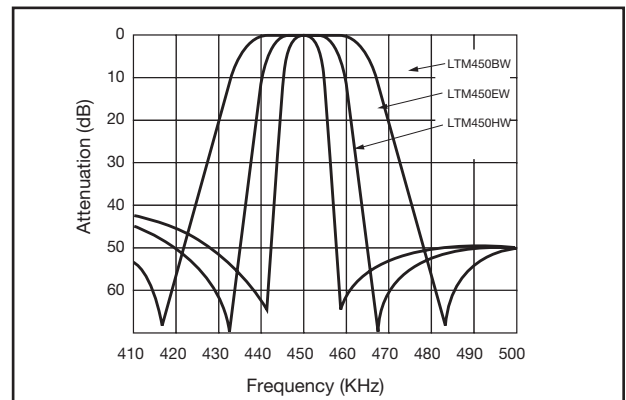

Figure 3) LTM450W – Characteristics