

Ultra small size high selectivity type ceramic filter for communication use.

## FEATURES

- Ultra small size
- 6.3 mm profile
- Broad bandwidth
- RoHS Compliant (Note 7 exemption)
- 6 elements

## OPERATING CONDITIONS/ELECTRICAL CHARACTERISTICS

PART NUMBER	CENTER FREQUENCY (KHz)	INSERTION LOSS (dB) MAX.	PASS BAND RIPPLE (dB) MAX.	6 dB BANDWIDTH (KHz) MIN.	50 dB BANDWIDTH (dB) MAX.	STOP BAND ATT. ±100KHZ (dB) MIN.	INPUT / OUTPUT IMPEDANCE (Ω)
LTM455BW	455 ±2.0	4	2	±15	±30	45	1500
LTM455CW	455 ±2.0	4	2	±12.5	±24	45	1500
LTM455DW	455 ±1.5	4	2	±10	±20	45	1500
LTM455EW	455 ±1.5	6	2	±7.5	±15	45	1500
LTM455FW	455 ±1.5	6	2	±6	±12.5	45	2000
LTM455GW	455 ±1.5	6	2	±4.5	±10	45	2000
LTM455HW	455 ±1.0	6	2	±3	±9	45	2000
LTM455IW	455 ±1.0	6	2	±2	±7.5	45	2000
LTM455HTW	455 ±1.0	6	2	±3	±9	60	2000
LTM455ITW	455 ±1.0	6	2	±2	±7.5	60	2000

## PACKAGE DIMENSIONS (mm)

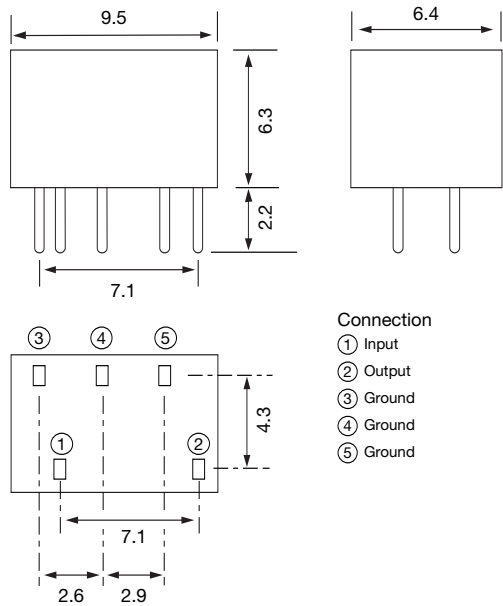

Figure 1) LTM455W – Front, Side and Bottom views

- Connection
- ① Input
  - ② Output
  - ③ Ground
  - ④ Ground
  - ⑤ Ground

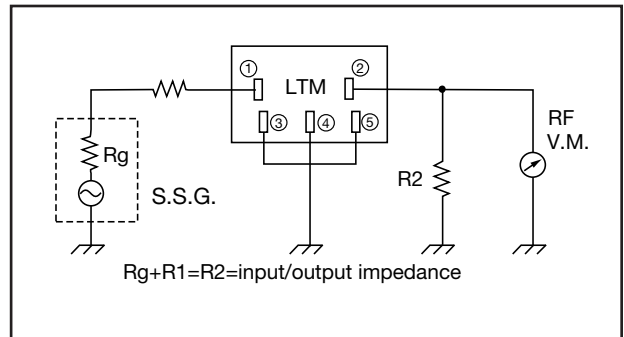

Figure 2) LTM455W – Measuring Circuit

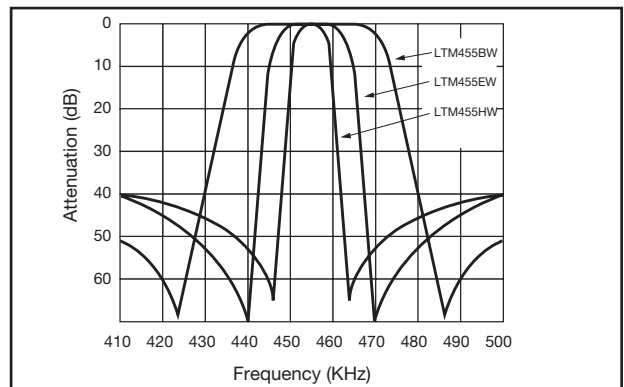

Figure 3) LTM455W – Characteristics

Note: To avoid potential problems, connect the output to an IF amplifier through a DC cut capacitor.  
Avoid applying a direct current to output end of the ceramic filters (between ⑤ and ②③④).