

FEATURES

Wide V_{CC} operation voltage : 2.4V ~ 5.5V

Very low power consumption :

$V_{CC} = 3.0V$	Operation current : 30mA (Max.) at 55ns 2mA (Max.) at 1MHz
	Standby current : 0.25uA (Typ.) at 25°C
$V_{CC} = 5.0V$	Operation current : 70mA (Max.) at 55ns 10mA (Max.) at 1MHz
	Standby current : 1.5uA (Typ.) at 25°C

High speed access time :

-55	55ns (Max.) at $V_{CC}=3.0\text{--}5.5V$
-70	70ns (Max.) at $V_{CC}=2.7\text{--}5.5V$

Automatic power down when chip is deselected

Easy expansion with \overline{CE} and \overline{OE} options

Three state outputs and TTL compatible

Fully static operation

Data retention supply voltage as low as 1.5V

DESCRIPTION

The BS62LV4006 is a high performance, very low power CMOS Static Random Access Memory organized as 524,288 by 8 bits and operates from a wide range of 2.4V to 5.5V supply voltage.

Advanced CMOS technology and circuit techniques provide both high speed and low power features with typical CMOS standby current of 0.25uA at 3.0V/25°C and maximum access time of 55ns at 3.0V/85°C.

Easy memory expansion is provided by an active LOW chip enable (\overline{CE}), and active LOW output enable (\overline{OE}) and three-state output drivers.

The BS62LV4006 has an automatic power down feature, reducing the power consumption significantly when chip is deselected.

The BS62LV4006 is available in DICE form, JEDEC standard 32 pin 450mil Plastic SOP, 600mil Plastic DIP, 400 mil TSOP II, 8mmx13.4mm STSOP and 8mmx20mm TSOP package.

POWER CONSUMPTION

PRODUCT FAMILY	OPERATING TEMPERATURE	POWER DISSIPATION								PKG TYPE
		STANDBY ($I_{CCSBY, Max}$)		Operating ($I_{CC, Max}$)						
		$V_{CC}=5.0V$	$V_{CC}=3.0V$	$V_{CC}=5V$			$V_{CC}=3V$			
				1MHz	10MHz	f_{Max}	1MHz	10MHz	f_{Max}	
BS62LV4006DC	Commercial +0°C to +70°C	10uA	2.0uA	9mA	43mA	68mA	1.5mA	18mA	29mA	DICE
BS62LV4006EC										TSOP II-32
BS62LV4006HC										BGA-36-0608
BS62LV4006PC										PDIP-32
BS62LV4006SC										SOP-32
BS62LV4006STC										STSOP-32
BS62LV4006TC	TSOP-32									
BS62LV4006EI	Industrial -40°C to +85°C	20uA	4.0uA	10mA	45mA	70mA	2mA	20mA	30mA	TSOP II-32
BS62LV4006HI										BGA-36-0608
BS62LV4006PI										PDIP-32
BS62LV4006SI										SOP-32
BS62LV4006STI										STSOP-32
BS62LV4006TI										TSOP-32

PIN CONFIGURATIONS

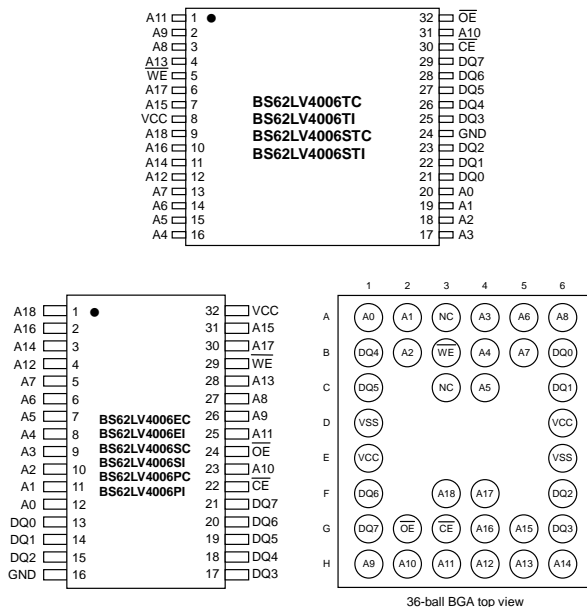

BLOCK DIAGRAM

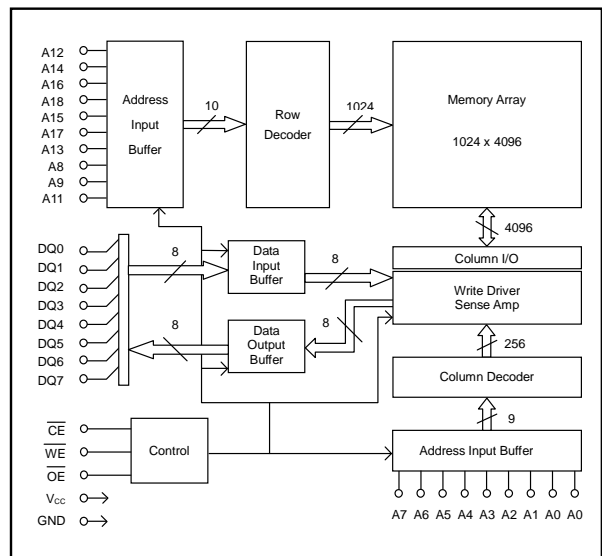

Brilliance Semiconductor, Inc. reserves the right to change products and specifications without notice.

n PIN DESCRIPTIONS

Name	Function
A0-A18 Address Input	These 19 address inputs select one of the 524,288 x 8-bit in the RAM
$\overline{\text{CE}}$ Chip Enable Input	$\overline{\text{CE}}$ is active LOW. Chip enable must be active when data read from or write to the device. If chip enable is not active, the device is deselected and is in standby power mode. The DQ pins will be in the high impedance state when the device is deselected.
$\overline{\text{WE}}$ Write Enable Input	The write enable input is active LOW and controls read and write operations. With the chip selected, when $\overline{\text{WE}}$ is HIGH and $\overline{\text{OE}}$ is LOW, output data will be present on the DQ pins; when $\overline{\text{WE}}$ is LOW, the data present on the DQ pins will be written into the selected memory location.
$\overline{\text{OE}}$ Output Enable Input	The output enable input is active LOW. If the output enable is active while the chip is selected and the write enable is inactive, data will be present on the DQ pins and they will be enabled. The DQ pins will be in the high impedance state when $\overline{\text{OE}}$ is inactive.
DQ0-DQ7 Data Input/Output Ports	There 8 bi-directional ports are used to read data from or write data into the RAM.
V_{CC}	Power Supply
GND	Ground

n TRUTH TABLE

MODE	$\overline{\text{CE}}$	$\overline{\text{WE}}$	$\overline{\text{OE}}$	I/O OPERATION	V _{CC} CURRENT
Not selected (Power Down)	H	X	X	High Z	I _{CCSB} , I _{CCSB1}
Output Disabled	L	H	H	High Z	I _{CC}
Read	L	H	L	D _{OUT}	I _{CC}
Write	L	L	X	D _{IN}	I _{CC}

n ABSOLUTE MAXIMUM RATINGS ⁽¹⁾

SYMBOL	PARAMETER	RATING	UNITS
V _{TERM}	Terminal Voltage with Respect to GND	-0.5 ⁽²⁾ to 7.0	V
T _{BIAS}	Temperature Under Bias	-40 to +125	°C
T _{STG}	Storage Temperature	-60 to +150	°C
P _T	Power Dissipation	1.0	W
I _{OUT}	DC Output Current	20	mA

1. Stresses greater than those listed under ABSOLUTE MAXIMUM RATINGS may cause permanent damage to the device. This is a stress rating only and functional operation of the device at these or any other conditions above those indicated in the operational sections of this specification is not implied. Exposure to absolute maximum rating conditions for extended periods may affect reliability.
2. -2.0V in case of AC pulse width less than 30 ns.

n OPERATING RANGE

RANG	AMBIENT TEMPERATURE	V _{CC}
Commercial	0°C to +70°C	2.4V ~ 5.5V
Industrial	-40°C to +85°C	2.4V ~ 5.5V

n CAPACITANCE ⁽¹⁾ (T_A = 25°C, f = 1.0MHz)

SYMBOL	PARAMETER	CONDITIONS	MAX.	UNITS
C _{IN}	Input Capacitance	V _{IN} = 0V	6	pF
C _{IO}	Input/Output Capacitance	V _{IO} = 0V	8	pF

1. This parameter is guaranteed and not 100% tested.

n DC ELECTRICAL CHARACTERISTICS (T_A = -40°C to +85°C)

PARAMETER NAME	PARAMETER	TEST CONDITIONS	MIN.	TYP. ⁽¹⁾	MAX.	UNITS
V _{CC}	Power Supply		2.4	--	5.5	V
V _{IL}	Input Low Voltage		-0.5 ⁽²⁾	--	0.8	V
V _{IH}	Input High Voltage		2.2	--	V _{CC} +0.3 ⁽³⁾	V
I _{IL}	Input Leakage Current	V _{CC} = Max, V _{IN} = 0V to V _{CC}	--	--	1	UA
I _{LO}	Output Leakage Current	V _{CC} = Max, $\overline{CE} = V_{IH}$, or $\overline{OE} = V_{IH}$, V _{I/O} = 0V to V _{CC}	--	--	1	UA
V _{OL}	Output Low Voltage	V _{CC} = Max, I _{OL} = 2.0mA	--	--	0.4	V
V _{OH}	Output High Voltage	V _{CC} = Min, I _{OH} = -1.0mA	2.4	--	--	V
I _{CC} ⁽⁵⁾	Operating Power Supply Current	$\overline{CE} = V_{IL}$, I _{DD} = 0mA, f = F _{MAX} ⁽⁴⁾	--	--	30 70	mA
I _{CC1}	Operating Power Supply Current	$\overline{CE} = V_{IL}$, I _{DD} = 0mA, f = 1MHz	--	--	2 10	mA
I _{CCSB}	Standby Current – TTL	$\overline{CE} = V_{IH}$, I _{DD} = 0mA	--	--	0.5 1.0	mA
I _{CCSB1} ⁽⁶⁾	Standby Current – CMOS	$\overline{CE} \geq V_{CC}-0.2V$, V _{IN} $\geq V_{CC}-0.2V$ or V _{IN} $\leq 0.2V$	--	0.25 1.5	4.0 20	uA

1. Typical characteristics are at T_A=25°C and not 100% tested.
2. Undershoot: -1.0V in case of pulse width less than 20 ns.
3. Overshoot: V_{CC}+1.0V in case of pulse width less than 20 ns.

4. F_{MAX}=1/t_{RC}.
5. I_{CC}(MAX.) is 29mA/68mA at V_{CC}=3.0V/5.0V and T_A=70°C.
6. I_{CCSB1}(MAX.) is 2.0uA/10uA at V_{CC}=3.0V/5.0V and T_A=70°C.

n DATA RETENTION CHARACTERISTICS (T_A = -40°C to +85°C)

SYMBOL	PARAMETER	TEST CONDITIONS	MIN.	TYP. ⁽¹⁾	MAX.	UNITS
V _{DR}	V _{CC} for Data Retention	$\overline{CE} \geq V_{CC}-0.2V$, V _{IN} $\geq V_{CC}-0.2V$ or V _{IN} $\leq 0.2V$	1.5	--	--	V
I _{CCDR} ⁽³⁾	Data Retention Current	$\overline{CE} \geq V_{CC}-0.2V$, V _{IN} $\geq V_{CC}-0.2V$ or V _{IN} $\leq 0.2V$	--	0.1	1.5	uA
t _{CDR}	Chip Deselect to Data Retention Time	See Retention Waveform	0	--	--	ns
t _R	Operation Recovery Time		t _{RC} ⁽²⁾	--	--	ns

1. V_{CC}=1.5V, T_A=25°C and not 100% tested.
2. t_{RC} = Read Cycle Time.
3. I_{CCDR}(MAX.) is 1.0uA at T_A=70°C.

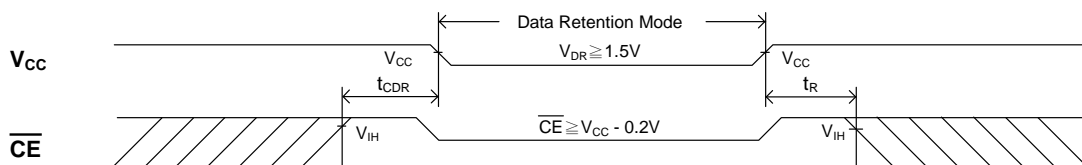
n LOW V_{CC} DATA RETENTION WAVEFORM (1) (\overline{CE} Controlled)

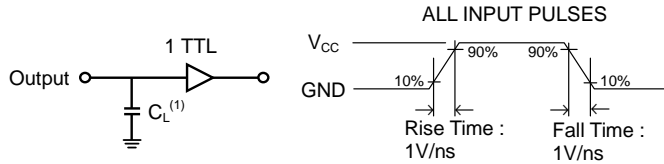

n AC TEST CONDITIONS
 (Test Load and Input/Output Reference)

Input Pulse Levels	$V_{CC} / 0V$
Input Rise and Fall Times	1V/ns
Input and Output Timing Reference Level	0.5V _{CC}
Output Load	$t_{CLZ}, t_{OLZ}, t_{CHZ}, t_{OHZ}, t_{WHZ}$
	Others

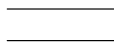
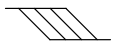
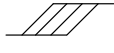

1. Including jig and scope capacitance.

n KEY TO SWITCHING WAVEFORMS

WAVEFORM	INPUTS	OUTPUTS
	MUST BE STEADY	MUST BE STEADY
	MAY CHANGE FROM "H" TO "L"	WILL BE CHANGE FROM "H" TO "L"
	MAY CHANGE FROM "L" TO "H"	WILL BE CHANGE FROM "L" TO "H"
	DON'T CARE ANY CHANGE PERMITTED	CHANGE : STATE UNKNOWN
	DOES NOT APPLY	CENTER LINE IS HIGH IMPEDANCE "OFF" STATE

n AC ELECTRICAL CHARACTERISTICS (T_A = -40°C to +85°C)
READ CYCLE

JEDEC PARAMETER NAME	PARAMETER NAME	DESCRIPTION	CYCLE TIME : 55ns (V _{CC} = 3.0-5.5V)			CYCLE TIME : 70ns (V _{CC} = 2.7-5.5V)			UNITS
			MIN.	TYP.	MAX.	MIN.	TYP.	MAX.	
t _{AVAX}	t _{RC}	Read Cycle Time	55	--	--	70	--	--	ns
t _{AVQX}	t _{AA}	Address Access Time	--	--	55	--	--	70	ns
t _{E1LQV}	t _{ACS}	Chip Select Access Time	--	--	55	--	--	70	ns
t _{GLQV}	t _{OE}	Output Enable to Output Valid	--	--	30	--	--	35	ns
t _{E1LQX}	t _{CLZ}	Chip Select to Output Low Z	10	--	--	10	--	--	ns
t _{GLQX}	t _{OLZ}	Output Enable to Output Low Z	5	--	--	5	--	--	ns
t _{E1HQZ}	t _{CHZ}	Chip Select to Output High Z	--	--	30	--	--	35	ns
t _{GHQZ}	t _{OHZ}	Output Enable to Output High Z	--	--	25	--	--	30	ns
t _{AVQX}	t _{OH}	Data Hold from Address Change	10	--	--	10	--	--	ns

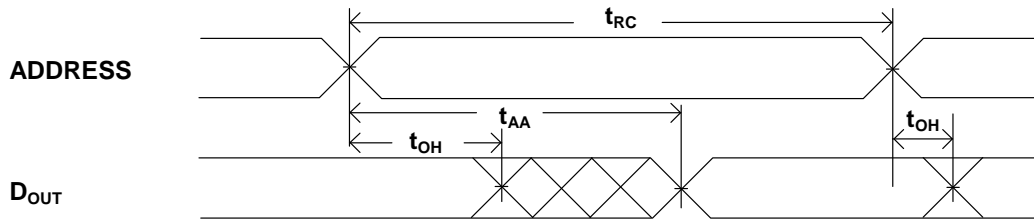
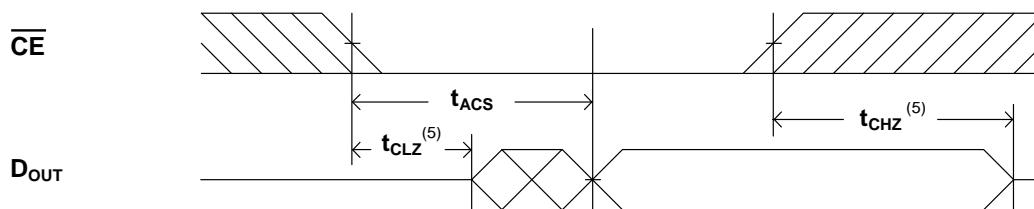
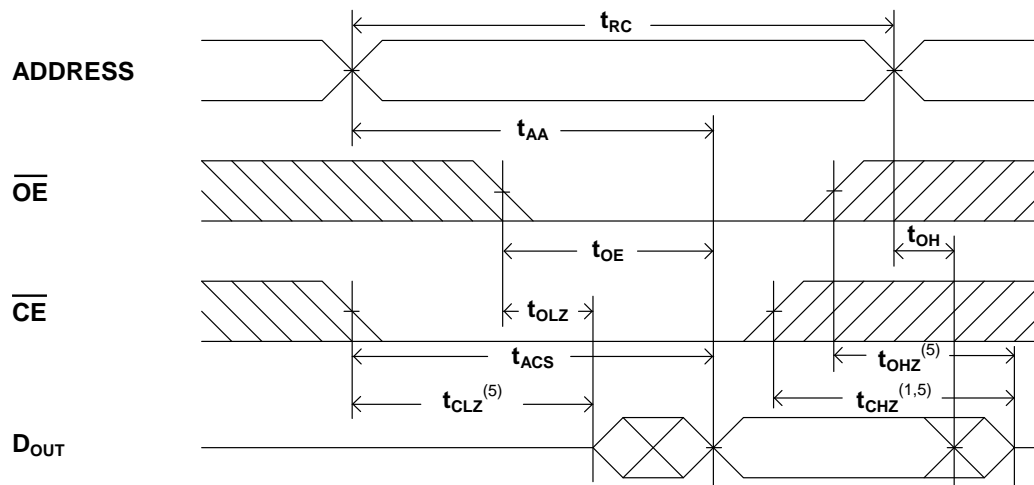
n SWITCHING WAVEFORMS (READ CYCLE)
READ CYCLE 1 ^(1,2,4)

READ CYCLE 2 ^(1,3,4)

READ CYCLE 3 ^(1,4)

NOTES:

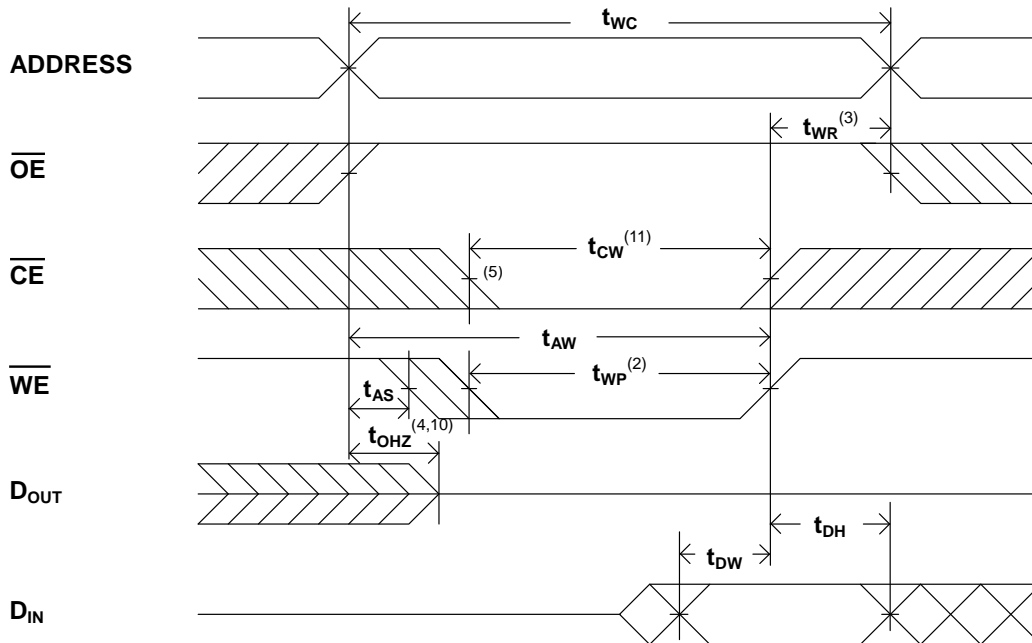
1. \overline{WE} is high in read Cycle.
2. Device is continuously selected when $\overline{CE} = V_{IL}$.
3. Address valid prior to or coincident with \overline{CE} transition low.
4. $OE = V_{IL}$.
5. Transition is measured $\pm 500mV$ from steady state with $C_L = 5pF$.
The parameter is guaranteed but not 100% tested.

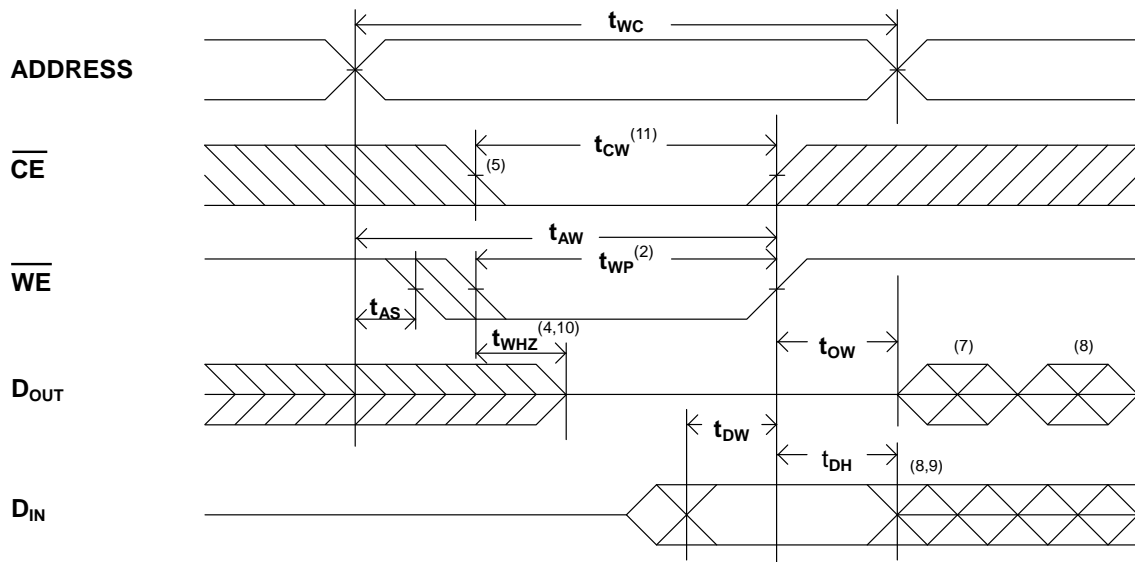
n AC ELECTRICAL CHARACTERISTICS (T_A = -40°C to +85°C)
WRITE CYCLE

JEDEC PARAMETER NAME	PARAMETER NAME	DESCRIPTION	CYCLE TIME : 55ns (V _{CC} = 3.0~5.5V)			CYCLE TIME : 70ns (V _{CC} = 2.7~5.5V)			UNITS
			MIN.	TYP.	MAX.	MIN.	TYP.	MAX.	
t _{AVAX}	t _{wc}	Write Cycle Time	55	--	--	70	--	--	ns
t _{E1LWH}	t _{cw}	Chip Select to End of Write	55	--	--	70	--	--	ns
t _{AVWL}	t _{AS}	Address Set up Time	0	--	--	0	--	--	ns
t _{AVWH}	t _{AW}	Address Valid to End of Write	55	--	--	70	--	--	ns
t _{WLWH}	t _{WP}	Write Pulse Width	30	--	--	35	--	--	ns
t _{WHAX}	t _{WR}	Write Recovery Time (\overline{CE} , \overline{WE})	0	--	--	0	--	--	ns
t _{WLQZ}	t _{WHZ}	Write to Output High Z	--	--	25	--	--	30	ns
t _{DVWH}	t _{DW}	Data to Write Time Overlap	25	--	--	30	--	--	ns
t _{WHDX}	t _{DH}	Data Hold from Write Time	0	--	--	0	--	--	ns
t _{GHQZ}	t _{OHZ}	Output Disable to Output in High Z	--	--	25	--	--	30	ns
t _{WHQX}	t _{OW}	End of Write to Output Active	5	--	--	5	--	--	ns

n SWITCHING WAVEFORMS (WRITE CYCLE)
WRITE CYCLE 1 ⁽¹⁾

WRITE CYCLE 2 ^(1,6)

NOTES:

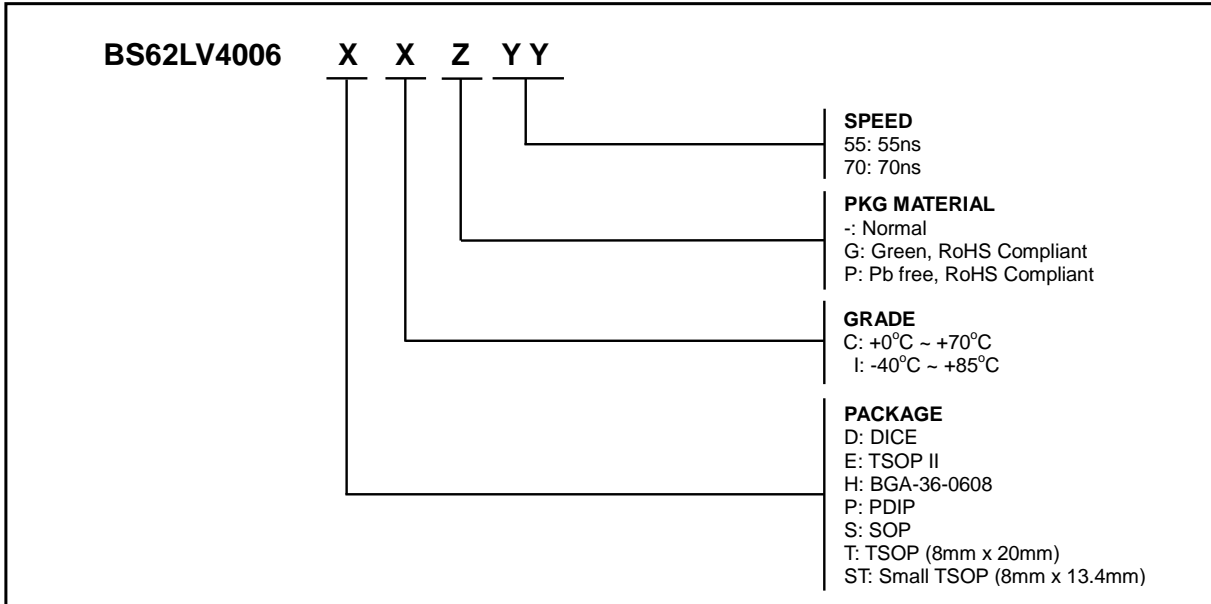
1. \overline{WE} must be high during address transitions.
2. The internal write time of the memory is defined by the overlap of \overline{CE} and \overline{WE} low. All signals must be active to initiate a write and any one signal can terminate a write by going inactive. The data input setup and hold timing should be referenced to the second transition edge of the signal that terminates the write.
3. t_{WR} is measured from the earlier of \overline{CE} or \overline{WE} going high at the end of write cycle.
4. During this period, DQ pins are in the output state so that the input signals of opposite phase to the outputs must not be applied.
5. If the \overline{CE} low transition occurs simultaneously with the \overline{WE} low transitions or after the \overline{WE} transition, output remain in a high impedance state.
6. \overline{OE} is continuously low ($\overline{OE} = V_{IL}$).
7. D_{OUT} is the same phase of write data of this write cycle.
8. D_{OUT} is the read data of next address.
9. If \overline{CE} is low during this period, DQ pins are in the output state. Then the data input signals of opposite phase to the outputs must not be applied to them.
10. Transition is measured $\pm 500\text{mV}$ from steady state with $C_L = 5\text{pF}$.
The parameter is guaranteed but not 100% tested.
11. t_{CW} is measured from the later of \overline{CE} going low to the end of write.

n ORDERING INFORMATION

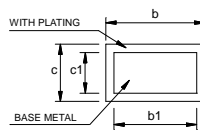
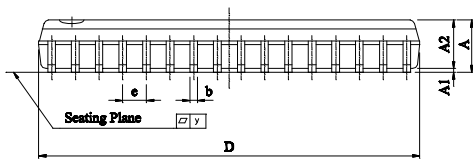
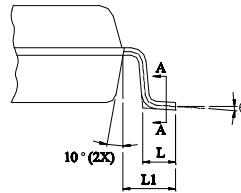
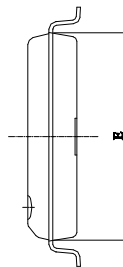
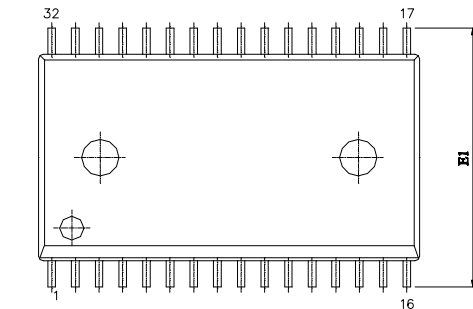
Note:

BSI (Brilliance Semiconductor Inc.) assumes no responsibility for the application or use of any product or circuit described herein. BSI does not authorize its products for use as critical components in any application in which the failure of the BSI product may be expected to result in significant injury or death, including life-support systems and critical medical instruments.

n PACKAGE DIMENSIONS

SECTION A-A

SYMBOL	UNIT	INCH	MM
A		0.111±0.007	2.821±0.176
A1		0.009±0.005	0.229±0.127
A2		0.1055±0.0055	2.680±0.140
b		0.014 ~ 0.020	0.35 ~ 0.50
b1		0.014 ~ 0.018	0.35 ~ 0.46
c		0.006 ~ 0.012	0.15 ~ 0.32
c1		0.006 ~ 0.011	0.15 ~ 0.28
D		0.805±0.005	20.447±0.127
E		0.445±0.005	11.303±0.127
E1		0.555±0.012	14.097±0.305
e		0.050±0.006	1.270±0.152
L		0.033±0.010	0.834±0.25
L1		0.055±0.008	1.397±0.203
y		0.004 Max.	0.1 Max.
θ		0° ~ 10°	0° ~ 10°

SOP -32

n PACKAGE DIMENSIONS (continued)

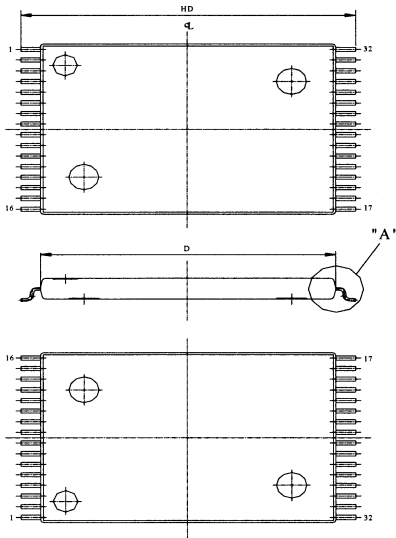

STSOP - 32

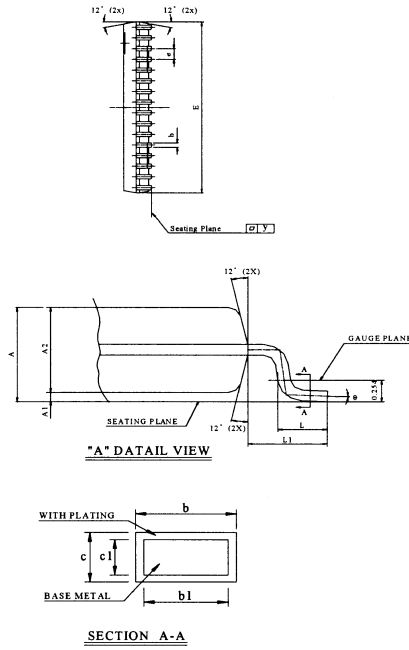

UNIT SYMBOL	INCH	MM
A	0.0433± 0.004	1.10± 0.10
A1	0.004± 0.002	0.10± 0.05
A2	0.039± 0.002	1.00± 0.05
b	0.009± 0.002	0.22± 0.05
b1	0.008± 0.001	0.20± 0.03
c	0.004 ~ 0.008	0.10 ~ 0.21
c1	0.004 ~ 0.006	0.10 ~ 0.16
D	0.465± 0.004	11.80± 0.10
E	0.315± 0.004	8.00± 0.10
e	0.020± 0.004	0.50± 0.10
HD	0.528± 0.008	13.40± 0.20
L	0.0197 ^{+0.008} / _{-0.004}	0.50 ^{+0.2} / _{-0.1}
L1	0.0315± 0.004	0.80± 0.10
y	0.004 Max.	0.1 Max.
θ	0° ~ 8°	0° ~ 8°

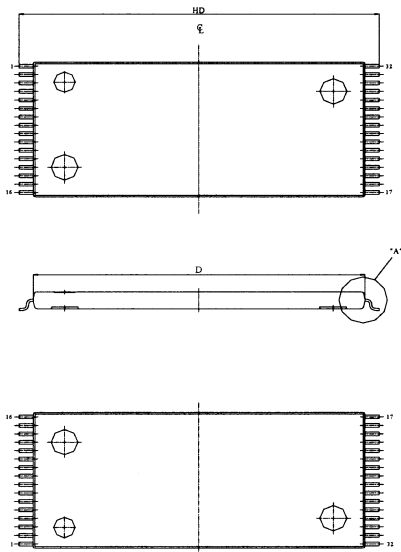

TSOP - 32

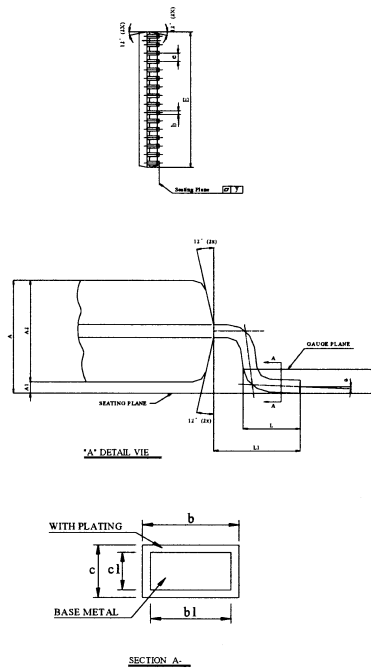

UNIT SYMBOL	INCH	MM
A	0.0433± 0.004	1.10± 0.10
A1	0.004± 0.002	0.10± 0.05
A2	0.039± 0.002	1.00± 0.05
b	0.009± 0.002	0.22± 0.05
b1	0.008± 0.001	0.20± 0.03
c	0.004 ~ 0.008	0.10 ~ 0.21
c1	0.004 ~ 0.006	0.10 ~ 0.16
D	0.724± 0.004	18.40± 0.10
E	0.315± 0.004	8.00± 0.10
e	0.020± 0.004	0.50± 0.10
HD	0.787± 0.008	20.00± 0.20
L	0.0197 ^{+0.008} / _{-0.004}	0.50 ^{+0.2} / _{-0.1}
L1	0.0315± 0.004	0.80± 0.10
y	0.004 Max.	0.1 Max.
θ	0° ~ 8°	0° ~ 8°

n PACKAGE DIMENSIONS (continued)

UNIT SYMBOL	INCH(BASE)	MM(REF)
A1	0.010(MIN)	0.254(MIN)
A2	0.154±0.005	3.912±0.127
B	0.018±0.005	0.457±0.127
B1	0.050±0.005	1.270±0.127
c	0.010±0.004	0.254±0.102
D	1.650±0.005	41.910±0.127
E	0.600±0.010	15.240±0.254
E1	0.544±0.004	13.818±0.102
e	0.100(TYP)	2.540(TYP)
eB	0.650±0.020	16.510±0.508
L	0.130±0.010	3.302±0.254
S	0.075±0.010	1.905±0.254
Q1	0.070±0.005	1.778±0.127

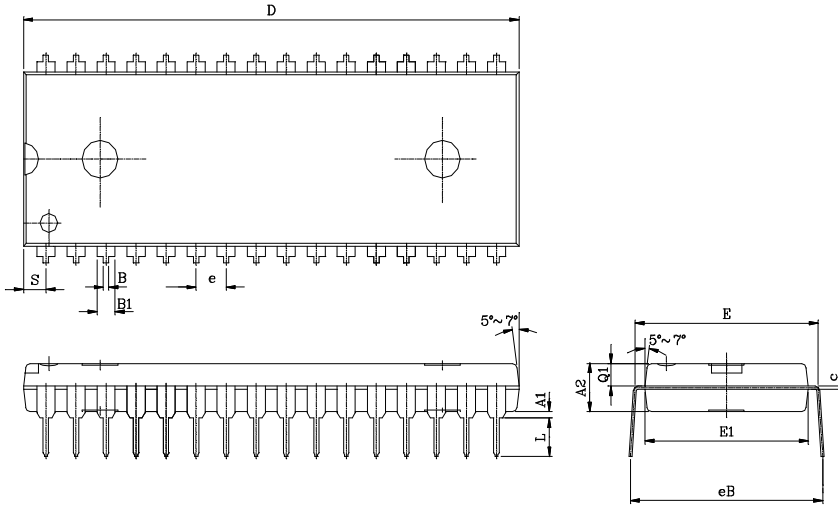
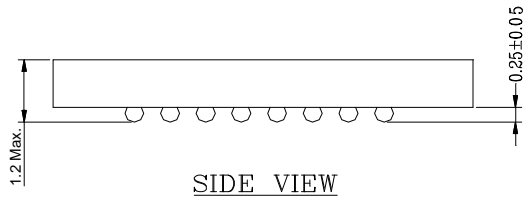
PDIP - 32

- NOTES
- 1: CONTROLLING DIMENSIONS ARE IN MILLIMETERS.
 - 2: PIN#1 DOT MARKING BY LASER OR PAD PRINT.
 - 3: SYMBOL "N" IS THE NUMBER OF SOLDER BALLS.

BALL PITCH e = 0.75				
D	E	N	D1	E1
8.0	6.0	48	5.25	3.75

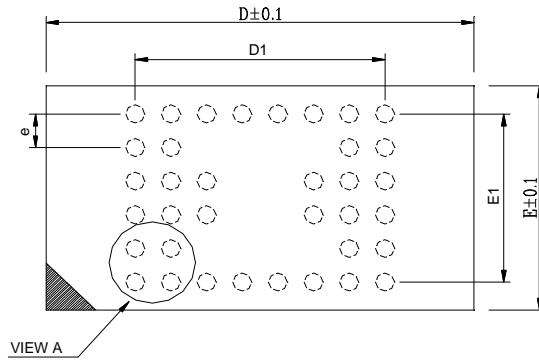
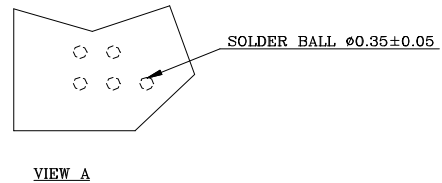
TOP VIEW
36 mini-BGA (6 x 8mm)

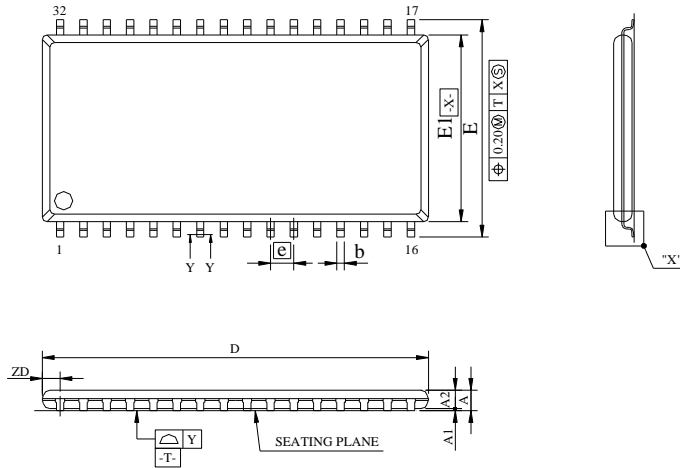
n PACKAGE DIMENSIONS (continued)

SYMBOL	DIMENSION (MM)			DIMENSION (INCH)		
	MIN.	NOM.	MAX.	MIN.	NOM.	MAX.
A			1.20			0.047
A1	0.05	0.10	0.15	0.002	0.004	0.006
A2	0.95	1.00	1.05	0.037	0.039	0.042
b	0.30		0.52	0.012		0.020
b1	0.30	0.40	0.45	0.012	0.016	0.018
c	0.12		0.21	0.005		0.008
c1	0.10	0.127	0.16	0.004	0.005	0.006
D	20.82	20.95	21.08	0.820	0.825	0.830
E	11.56	11.76	11.96	0.455	0.463	0.471
E1	10.03	10.16	10.29	0.394	0.400	0.405
E	1.27 BASIC			0.050 BASIC		
L	0.40	0.50	0.60	0.016	0.020	0.024
L1	0.25 BASIC			0.010 BASIC		
L2	0.8 REF			0.031 REF		
R	0.12		0.25	0.005		0.010
R1	0.12			0.005		
ZD	0.95 REF			0.037 REF		
Y			0.10			0.004

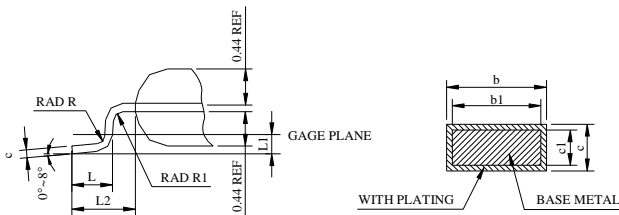

DETAIL "X"

SECTION Y-Y

TSOP II - 32

NOTE:

1. CONTROLLING DIMENSION : MILLIMETERS.
2. REFERENCE DOCUMENT : JEDEC MS-024
3. DIMENSION D DOES NOT INCLUDE MOLD PROTRUSION. MOLD PROTRUSION SHALL NOT EXCEED 0.15(0.006") PER SIDE. DIMENSION E1 DOES NOT INCLUDE INTERLEAD PROTRUSION. INTERLEAD PROTRUSION SHALL NOT EXCEED 0.25(0.01") PER SIDE.
4. DIMENSION b DOES NOT INCLUDE DAMBAR PROTRUSIONS/INTRUSION. ALLOWABLE DAMBAR PROTRUSION SHALL NOT CAUSE THE LEAD TO BE WIDER THAN THE MAX b DIMENSION BY MORE THAN 0.13mm. DAMBAR INTRUSION SHALL NOT CAUSE THE LEAD TO BE NARROWER THAN THE MIN b DIMENSION BY MORE THAN 0.07mm.

n Revision History

<u>Revision No.</u>	<u>History</u>	<u>Draft Date</u>	<u>Remark</u>
1.2	To add Icc1 characteristic parameter To improve Iccsb1 spec. I-grade from 60uA to 20uA at 5.0V 10uA to 4.0uA at 3.0V C-grade from 30uA to 10uA at 5.0V 5.0uA to 2.0uA at 3.0V	Jan. 13, 2006	
1.3	To Add 400 mil TSOP II package type	March 20, 2006	
1.4	Change I-grade operation temperature range - from -25°C to -40°C	May. 25, 2006	