



Very Low Power/Voltage CMOS SRAM 128K X 8 bit

BS62LV1023

FEATURES

- Vcc operation voltage : 2.4V ~ 3.6V
- Very low power consumption :
 - Vcc = 3.0V C-grade : 20mA (Max.) operating current
 - I-grade : 25mA (Max.) operating current
 - 0.02uA (Typ.) CMOS standby current
- High speed access time :
 - 70 70ns (Max.) at Vcc = 3.0V
- Automatic power down when chip is deselected
- Three state outputs and TTL compatible
- Fully static operation
- Data retention supply voltage as low as 1.5V
- Easy expansion with CE2, CE1, and OE options

DESCRIPTION

The BS62LV1023 is a high performance, very low power CMOS Static Random Access Memory organized as 131,072 words by 8 bits and operates from a wide range of 2.4V to 3.6V supply voltage. Advanced CMOS technology and circuit techniques provide both high speed and low power features with a typical CMOS standby current of 0.02uA and maximum access time of 70ns in 3V operation. Easy memory expansion is provided by an active LOW chip enable (CE1), an active HIGH chip enable (CE2), and active LOW output enable (OE) and three-state output drivers. The BS62LV1023 has an automatic power down feature, reducing the power consumption significantly when chip is deselected. The BS62LV1023 is available in DICE form, JEDEC standard 32 pin 450mil Plastic SOP, 300mil Plastic SOJ, 600mil Plastic DIP, 8mmx13.4mm STSOP and 8mmx20mm TSOP.

PRODUCT FAMILY

PRODUCT FAMILY	OPERATING TEMPERATURE	Vcc RANGE	SPEED (ns)	POWER DISSIPATION		PKG TYPE
				STANDBY (IccSB1, Max)	Operating (Icc, Max)	
				Vcc=3.0V	Vcc=3.0V	
BS62LV1023SC	+0 °C to +70 °C	2.4V ~ 3.6V	70	1.0uA	20mA	SOP-32
BS62LV1023TC						TSOP-32
BS62LV1023STC						STSOP-32
BS62LV1023PC						PDIP-32
BS62LV1023JC						SOJ-32
BS62LV1023DC						DICE
BS62LV1023SI	-40 °C to +85 °C	2.4V ~ 3.6V	70	1.5uA	25mA	SOP-32
BS62LV1023TI						TSOP-32
BS62LV1023STI						STSOP-32
BS62LV1023PI						PDIP-32
BS62LV1023JI						SOJ-32
BS62LV1023DI						DICE

PIN CONFIGURATIONS

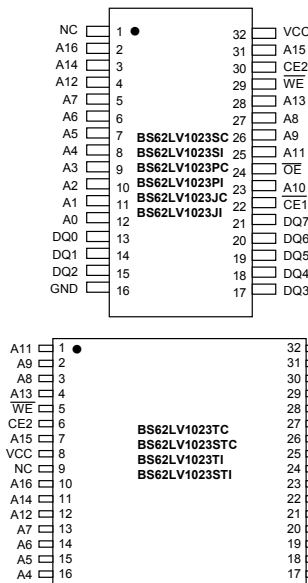

BLOCK DIAGRAM

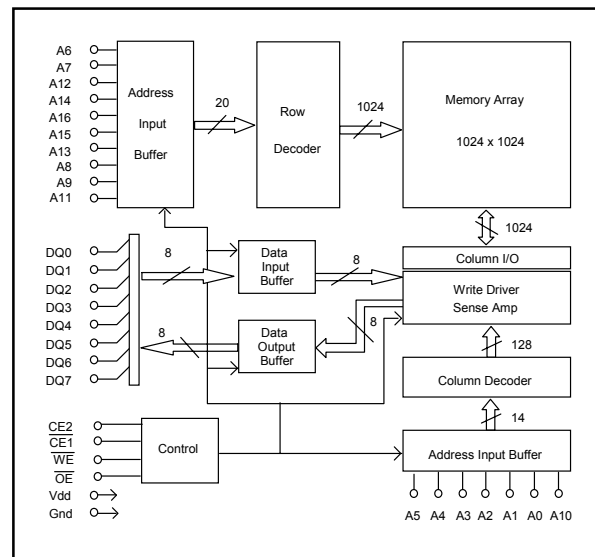

Brilliance Semiconductor Inc. reserves the right to modify document contents without notice.

■ PIN DESCRIPTIONS

Name	Function
A0-A16 Address Input	These 17 address inputs select one of the 131,072 x 8-bit words in the RAM
CE1 Chip Enable 1 Input CE2 Chip Enable 2 Input	$\overline{CE1}$ is active LOW and CE2 is active HIGH. Both chip enables must be active when data read from or write to the device. If either chip enable is not active, the device is deselected and is in a standby power mode. The DQ pins will be in the high impedance state when the device is deselected.
\overline{WE} Write Enable Input	The write enable input is active LOW and controls read and write operations. With the chip selected, when \overline{WE} is HIGH and \overline{OE} is LOW, output data will be present on the DQ pins; when \overline{WE} is LOW, the data present on the DQ pins will be written into the selected memory location.
\overline{OE} Output Enable Input	The output enable input is active LOW. If the output enable is active while the chip is selected and the write enable is inactive, data will be present on the DQ pins and they will be enabled. The DQ pins will be in the high impedance state when \overline{OE} is inactive.
DQ0-DQ7 Data Input/Output Ports	These 8 bi-directional ports are used to read data from or write data into the RAM.
Vcc	Power Supply
Gnd	Ground

■ TRUTH TABLE

MODE	\overline{WE}	$\overline{CE1}$	CE2	\overline{OE}	I/O OPERATION	Vcc CURRENT
Not selected (Power Down)	X	H	X	X	High Z	I_{CCSB}, I_{CCSB1}
	X	X	L	X		
Output Disabled	H	L	H	H	High Z	I_{CC}
Read	H	L	H	L	D OUT	I_{CC}
Write	L	L	H	X	D IN	I_{CC}

■ ABSOLUTE MAXIMUM RATINGS⁽¹⁾

SYMBOL	PARAMETER	RATING	UNITS
V TERM	Terminal Voltage with Respect to GND	-0.5 to Vcc+0.5	V
T BIAS	Temperature Under Bias	-40 to +125	°C
T STG	Storage Temperature	-60 to +150	°C
P T	Power Dissipation	1.0	W
I OUT	DC Output Current	20	mA

1. Stresses greater than those listed under ABSOLUTE MAXIMUM RATINGS may cause permanent damage to the device. This is a stress rating only and functional operation of the device at these or any other conditions above those indicated in the operational sections of this specification is not implied. Exposure to absolute maximum rating conditions for extended periods may affect reliability.

■ OPERATING RANGE

RANGE	AMBIENT TEMPERATURE	Vcc
Commercial	0 °C to +70 °C	2.4V ~ 3.6V
Industrial	-40 °C to +85 °C	2.4V ~ 3.6V

■ CAPACITANCE ⁽¹⁾ (TA = 25°C, f = 1.0 MHz)

SYMBOL	PARAMETER	CONDITIONS	MAX.	UNIT
CIN	Input Capacitance	VIN=0V	6	pF
CDQ	Input/Output Capacitance	VII/O=0V	8	pF

1. This parameter is guaranteed and not tested.

DC ELECTRICAL CHARACTERISTICS (TA = 0°C to + 70°C)

PARAMETER NAME	PARAMETER	TEST CONDITIONS	MIN.	TYP. ⁽¹⁾	MAX.	UNITS
V _{IL}	Guaranteed Input Low Voltage ⁽²⁾	V _{CC} =3.0V	-0.5	--	0.8	V
V _{IH}	Guaranteed Input High Voltage ⁽²⁾	V _{CC} =3.0V	2.0	--	V _{CC} +0.2	V
I _{IL}	Input Leakage Current	V _{CC} = Max, V _{IN} = 0V to V _{CC}	--	--	1	µA
I _{OL}	Output Leakage Current	V _{CC} = Max, $\overline{CE1} = V_{IH}$, CE2 = V _{IL} or $\overline{OE} = V_{IH}$, V _{IO} = 0V to V _{CC}	--	--	1	µA
V _{OL}	Output Low Voltage	V _{CC} = Max, I _{OL} = 2mA	--	--	0.4	V
V _{OH}	Output High Voltage	V _{CC} = Min, I _{OH} = -1mA	2.4	--	--	V
I _{CC}	Operating Power Supply Current	$\overline{CE1} = V_{IL}$, or CE2 = V _{IH} , I _{DD} = 0mA, F = Fmax ⁽³⁾	--	--	20	mA
I _{CCSB}	Standby Current-TTL	$\overline{CE1} = V_{IH}$, or CE2 = V _{IL} , I _{DD} = 0mA, F = Fmax ⁽³⁾	--	--	1	mA
I _{CCSB1}	Standby Current-CMOS	$\overline{CE1} \geq V_{CC} - 0.2V$, CE2 $\leq 0.2V$, V _{IN} $\geq V_{CC} - 0.2V$ or V _{IN} $\leq 0.2V$	--	0.02	1.0	µA

1. Typical characteristics are at TA = 25°C.

2. These are absolute values with respect to device ground and all overshoots due to system or tester noise are included.

3. Fmax = 1/t_{RC}.

DATA RETENTION CHARACTERISTICS (TA = 0°C to + 70°C)

SYMBOL	PARAMETER	TEST CONDITIONS	MIN.	TYP. ⁽¹⁾	MAX.	UNITS
V _{DR}	V _{CC} for Data Retention	$\overline{CE1} \geq V_{CC} - 0.2V$, CE2 $\leq 0.2V$, V _{IN} $\geq V_{CC} - 0.2V$ or V _{IN} $\leq 0.2V$	1.5	--	--	V
I _{CCDR}	Data Retention Current	$\overline{CE1} \geq V_{CC} - 0.2V$, CE2 $\leq 0.2V$, V _{IN} $\geq V_{CC} - 0.2V$ or V _{IN} $\leq 0.2V$	--	0.02	0.3	µA
t _{CDR}	Chip Deselect to Data Retention Time	See Retention Waveform	0	--	--	ns
t _R	Operation Recovery Time		T _{RC} ⁽²⁾	--	--	ns

1. V_{CC} = 1.5V, T_A = + 25°C



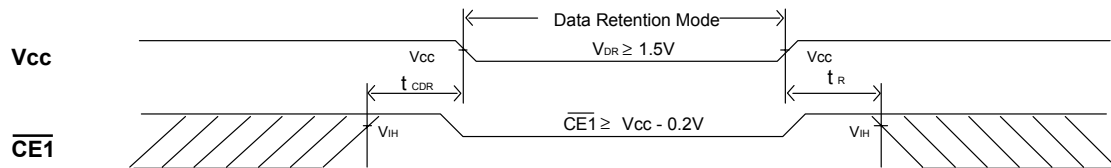
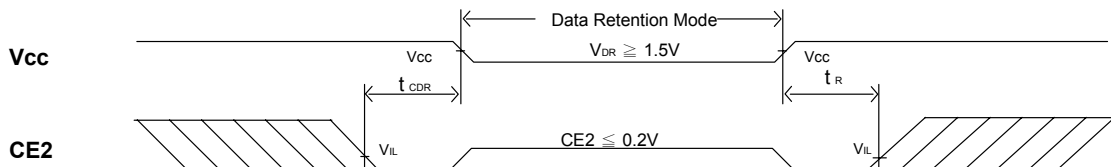

2. t_{RC} = Read Cycle Time

LOW V_{CC} DATA RETENTION WAVEFORM (1) ($\overline{CE1}$ Controlled)

LOW V_{CC} DATA RETENTION WAVEFORM (2) (CE2 Controlled)

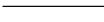
■ AC TEST CONDITIONS

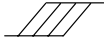
Input Pulse Levels	V _{cc} /0V
Input Rise and Fall Times	5ns
Input and Output Timing Reference Level	0.5V _{cc}

■ KEY TO SWITCHING WAVEFORMS

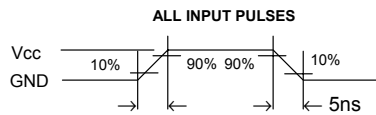
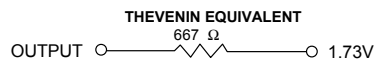
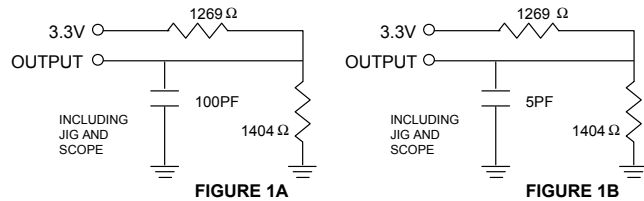
WAVEFORM	INPUTS	OUTPUTS
	MUST BE STEADY	MUST BE STEADY
	MAY CHANGE FROM H TO L	WILL BE CHANGE FROM H TO L
	MAY CHANGE FROM L TO H	WILL BE CHANGE FROM L TO H
	DON'T CARE: ANY CHANGE PERMITTED	CHANGE: STATE UNKNOWN
	DOES NOT APPLY	CENTER LINE IS HIGH IMPEDANCE "OFF" STATE

■ AC TEST LOADS AND WAVEFORMS

FIGURE 2
■ AC ELECTRICAL CHARACTERISTICS (TA = 0°C to + 70°C, V_{cc}=3.0V)
READ CYCLE

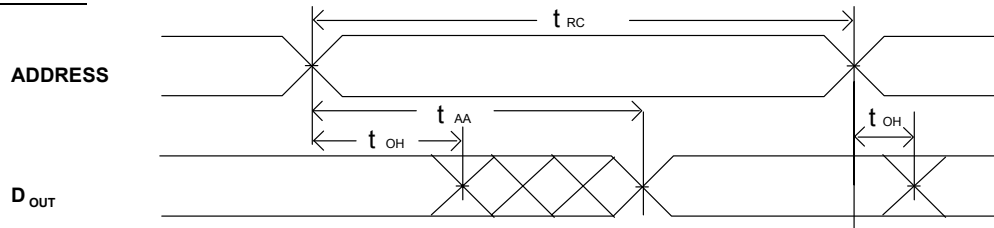
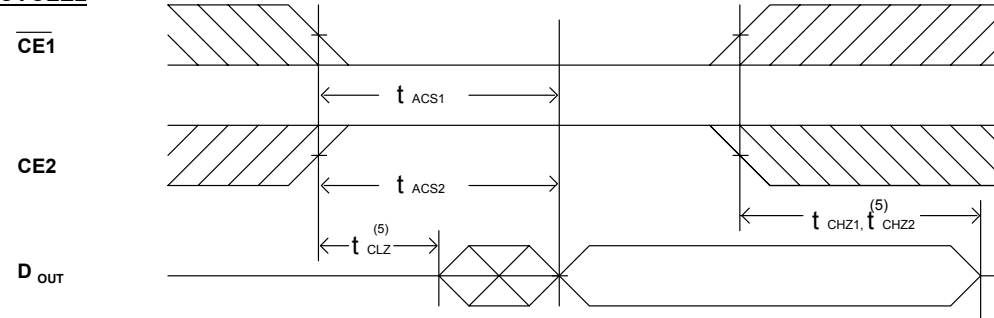
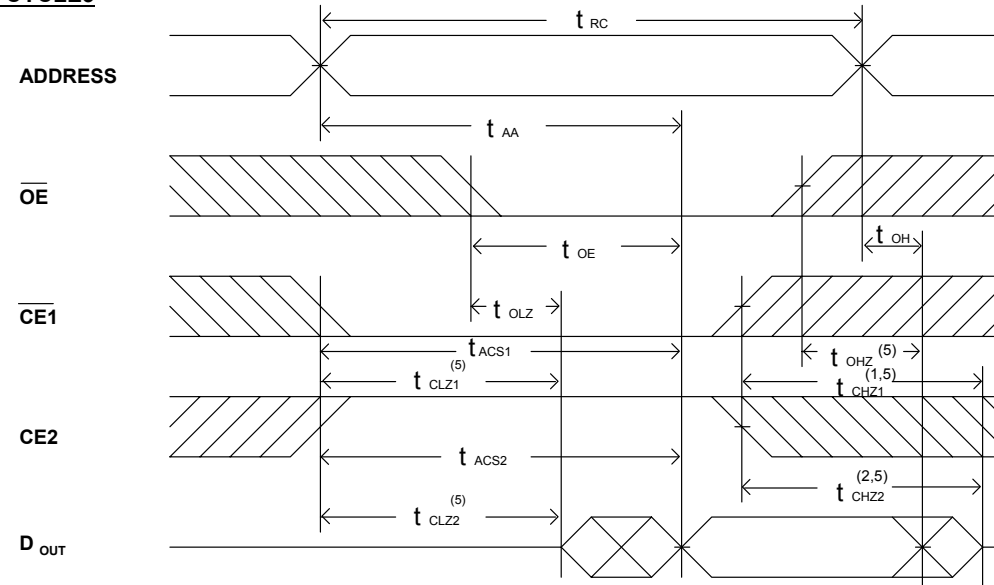
JEDEC PARAMETER NAME	PARAMETER NAME	DESCRIPTION	BS62LV1023-70			UNIT
			MIN.	TYP.	MAX.	
t _{AVAX}	t _{RC}	Read Cycle Time	70	--	--	ns
t _{AVQV}	t _{AA}	Address Access Time	--	--	70	ns
t _{E1LQV}	t _{ACS1}	Chip Select Access Time (CE1)	--	--	70	ns
t _{E2HOV}	t _{ACS2}	Chip Select Access Time (CE2)	--	--	70	ns
t _{GLQV}	t _{OE}	Output Enable to Output Valid	--	--	50	ns
t _{E1LQX}	t _{CLZ1}	Chip Select to Output Low Z (CE1)	10	--	--	ns
t _{E2HOX}	t _{CLZ2}	Chip Select to Output Low Z (CE2)	10	--	--	ns
t _{GLQX}	t _{OLZ}	Output Enable to Output in Low Z	10	--	--	ns
t _{E1HQZ}	t _{CHZ1}	Chip Deselect to Output in High Z (CE1)	0	--	40	ns
t _{E2HQZ}	t _{CHZ2}	Chip Deselect to Output in High Z (CE2)	0	--	40	ns
t _{GHQZ}	t _{OHZ}	Output Disable to Output in High Z	0	--	35	ns
t _{AXOX}	t _{OH}	Output Disable to Output Address Change	10	--	--	ns

SWITCHING WAVEFORMS (READ CYCLE)
READ CYCLE1 (1,2,4)

READ CYCLE2 (1,3,4)

READ CYCLE3 (1,4)

NOTES:

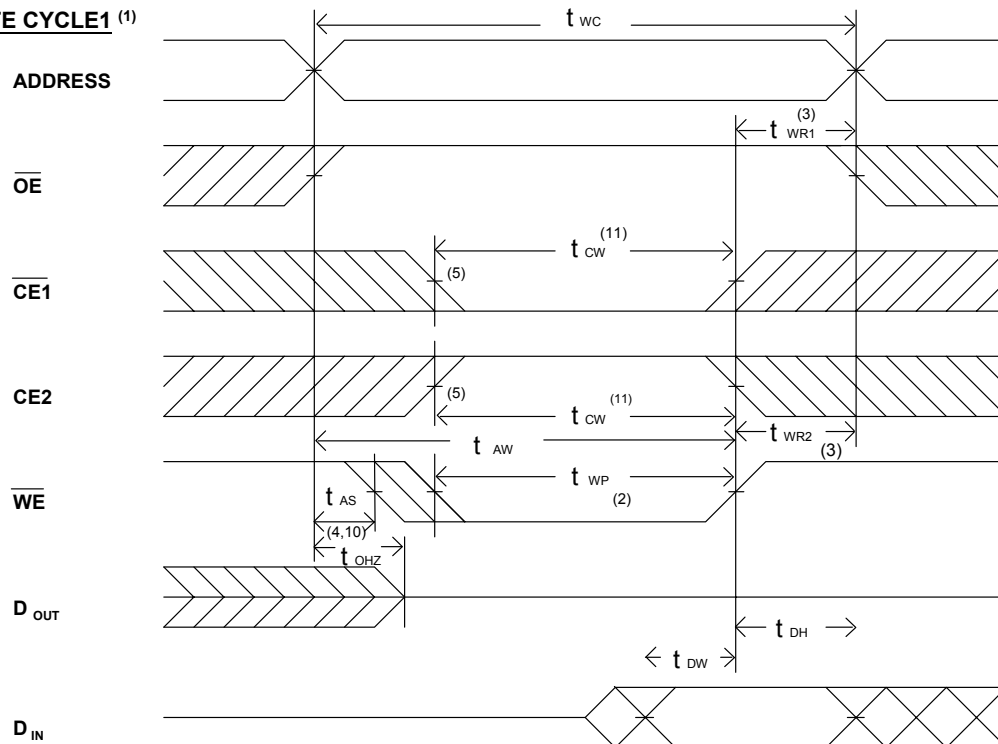
1. \overline{WE} is high in read Cycle.
2. Device is continuously selected when $\overline{CE1} = V_{IL}$ and $CE2 = V_{IH}$.
3. Address valid prior to or coincident with $\overline{CE1}$ transition low and/or $CE2$ transition high.
4. $\overline{OE} = V_{IL}$.
5. Transition is measured $\pm 500mV$ from steady state with $C_L = 5pF$ as shown in Figure 1B. The parameter is guaranteed but not 100% tested.

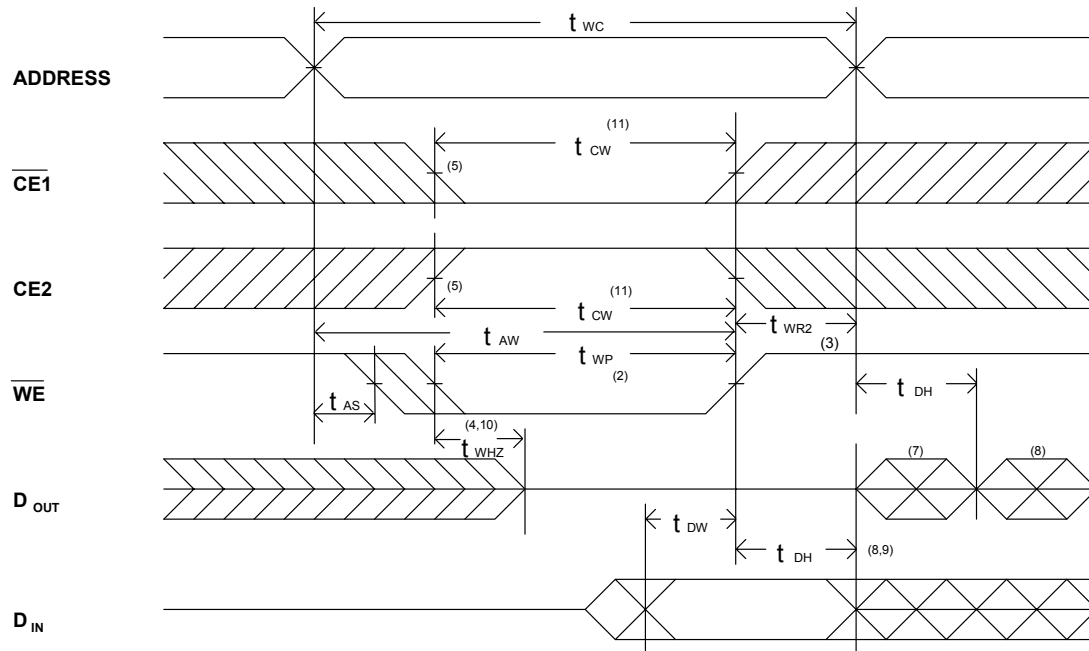
■ AC ELECTRICAL CHARACTERISTICS (TA = 0°C to + 70°C, Vcc=3.0V)
WRITE CYCLE

JEDEC PARAMETER NAME	PARAMETER NAME	DESCRIPTION	BS62LV1023-70			UNIT
			MIN.	TYP.	MAX.	
t_{AVAX}	t_{WC}	Write Cycle Time	70	--	--	ns
t_{E1LWH}	t_{CW}	Chip Select to End of Write	70	--	--	ns
t_{AVWL}	t_{AS}	Address Set up Time	0	--	--	ns
t_{AVWH}	t_{AW}	Address Valid to End of Write	70	--	--	ns
t_{WLWH}	t_{WP}	Write Pulse Width	50	--	--	ns
t_{WHAX}	t_{WR1}	Write Recovery Time ($\overline{CE1}$, \overline{WE})	0	--	--	ns
t_{E2LAX}	t_{WR2}	Write Recovery Time (CE2)	0	--	--	ns
t_{WLOZ}	t_{WHZ}	Write to Output in High Z	0	--	30	ns
t_{DVWH}	t_{DW}	Data to Write Time Overlap	30	--	--	ns
t_{WHDX}	t_{DH}	Data Hold from Write Time	0	--	--	ns
t_{GHOZ}	t_{OHZ}	Output Disable to Output in High Z	0	--	30	ns
t_{WHQX}	t_{OW}	End of Write to Output Active	5	--	--	ns

WRITE CYCLE1⁽¹⁾

WRITE CYCLE2 (1,6)

NOTES:

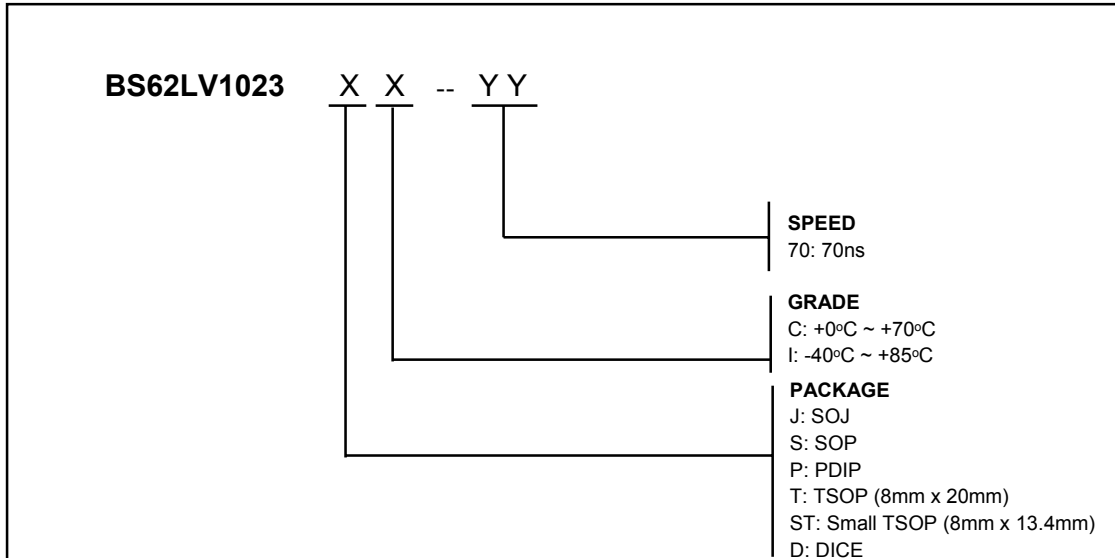
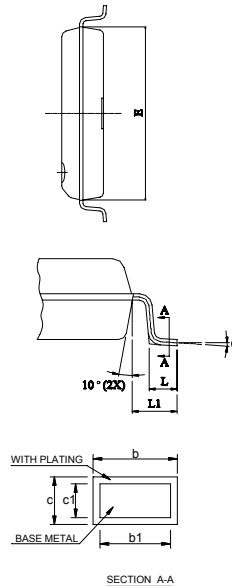
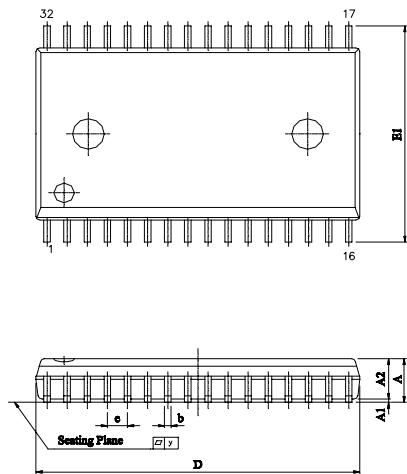
1. \overline{WE} must be high during address transitions.
2. The internal write time of the memory is defined by the overlap of $\overline{CE1}$ and CE2 active and \overline{WE} low. All signals must be active to initiate a write and any one signal can terminate a write by going inactive. The data input setup and hold timing should be referenced to the second transition edge of the signal that terminates the write.
3. t_{WR} is measured from the earlier of $\overline{CE1}$ or \overline{WE} going high or CE2 going low at the end of write cycle.
4. During this period, DQ pins are in the output state so that the input signals of opposite phase to the outputs must not be applied.
5. If the $\overline{CE1}$ low transition or the CE2 high transition occurs simultaneously with the \overline{WE} low transitions or after the \overline{WE} transition, output remain in a high impedance state.
6. \overline{OE} is continuously low ($\overline{OE} = V_{IL}$).
7. D_{OUT} is the same phase of write data of this write cycle.
8. D_{OUT} is the read data of next address.
9. If $\overline{CE1}$ is low and CE2 is high during this period, DQ pins are in the output state. Then the data input signals of opposite phase to the outputs must not be applied to them.
10. Transition is measured $\pm 500\text{mV}$ from steady state with $C_L = 5\text{pF}$ as shown in Figure 1B. The parameter is guaranteed but not 100% tested.
11. t_{CW} is measured from the later of $\overline{CE1}$ going low or CE2 going high to the end of write.

ORDERING INFORMATION

PACKAGE DIMENSIONS

SYMBOL	UNIT	INCH	MM
A		0.111±0.007	2.821±0.176
A1		0.009±0.005	0.229±0.127
A2		0.1055±0.0055	2.680±0.140
b		0.014 ~ 0.020	0.35 ~ 0.50
b1		0.014 ~ 0.018	0.35 ~ 0.46
c		0.006 ~ 0.012	0.15 ~ 0.32
c1		0.006 ~ 0.011	0.15 ~ 0.28
D		0.805±0.005	20.447±0.127
E		0.445±0.005	11.303±0.127
E1		0.555±0.012	14.097±0.305
e		0.050±0.006	1.270±0.152
L		0.033±0.010	0.834±0.25
L1		0.055±0.008	1.397±0.203
y		0.004 Max.	0.1 Max.
θ		0° ~ 10°	0° ~ 10°

SOP -32

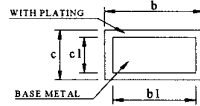
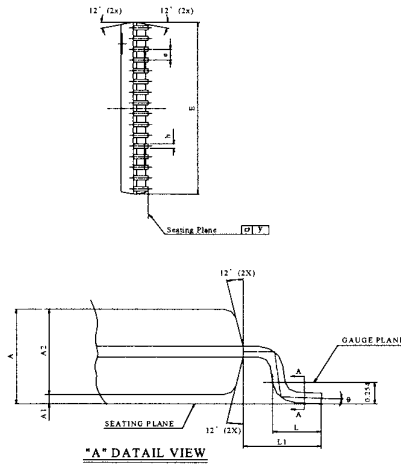
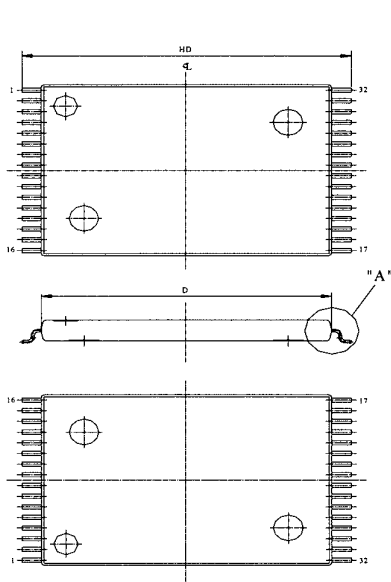
■ PACKAGE DIMENSIONS (continued)



SECTION A-A

UNIT	INCH	MM
A	0.0433± 0.004	1.10± 0.10
A1	0.004± 0.002	0.10± 0.05
A2	0.039± 0.002	1.00± 0.05
b	0.009± 0.002	0.22± 0.05
b1	0.008± 0.001	0.20± 0.03
c	0.004 ~ 0.008	0.10 ~ 0.21
c1	0.004 ~ 0.006	0.10 ~ 0.16
D	0.465± 0.004	11.80± 0.10
E	0.315± 0.004	8.00± 0.10
e	0.020± 0.004	0.50± 0.10
HD	0.528± 0.008	13.40± 0.20
L	0.0197 ^{+0.008} / _{-0.004}	0.50 ^{+0.2} / _{-0.1}
L1	0.0315± 0.004	0.80± 0.10
y	0.004 Max.	0.1 Max.
θ	0° ~ 8°	0° ~ 8°

STSOP - 32

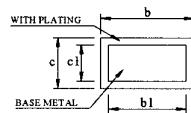
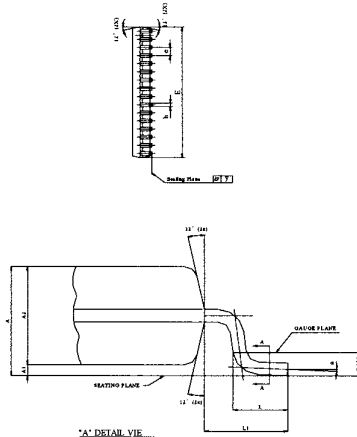
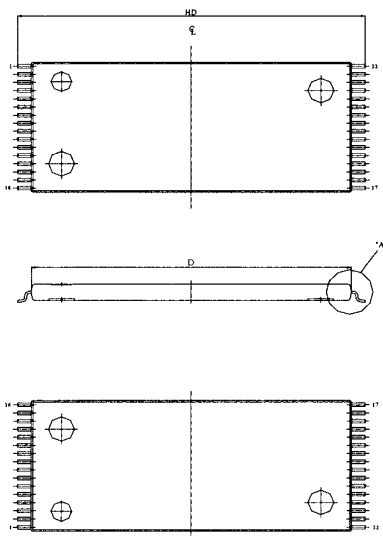

SECTION A-A

UNIT	INCH	MM
A	0.0433± 0.004	1.10± 0.10
A1	0.004± 0.002	0.10± 0.05
A2	0.039± 0.002	1.00± 0.05
b	0.009± 0.002	0.22± 0.05
b1	0.008± 0.001	0.20± 0.03
c	0.004 ~ 0.008	0.10 ~ 0.21
c1	0.004 ~ 0.006	0.10 ~ 0.16
D	0.724± 0.004	18.40± 0.10
E	0.315± 0.004	8.00± 0.10
e	0.020± 0.004	0.50± 0.10
HD	0.787± 0.008	20.00± 0.20
L	0.0197 ^{+0.008} / _{-0.004}	0.50 ^{+0.2} / _{-0.1}
L1	0.0315± 0.004	0.80± 0.10
y	0.004 Max.	0.1 Max.
θ	0° ~ 8°	0° ~ 8°

TSOP - 32

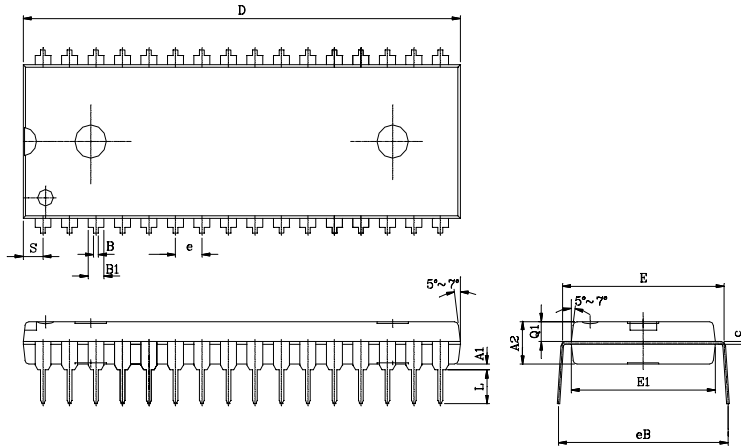
■ PACKAGE DIMENSIONS (continued)

UNIT SYMBOL	INCH(BASE)	MM(REF)
A1	0.010(MIN)	0.254(MIN)
A2	0.154±0.005	3.912±0.127
B	0.018±0.005	0.457±0.127
B1	0.050±0.005	1.270±0.127
c	0.010±0.004	0.254±0.102
D	1.650±0.005	41.910±0.127
E	0.600±0.010	15.240±0.254
E1	0.544±0.004	13.818±0.102
e	0.100(TYP)	2.540(TYP)
eB	0.650±0.020	16.510±0.508
L	0.130±0.010	3.302±0.254
S	0.075±0.010	1.905±0.254
Q1	0.070±0.005	1.778±0.127

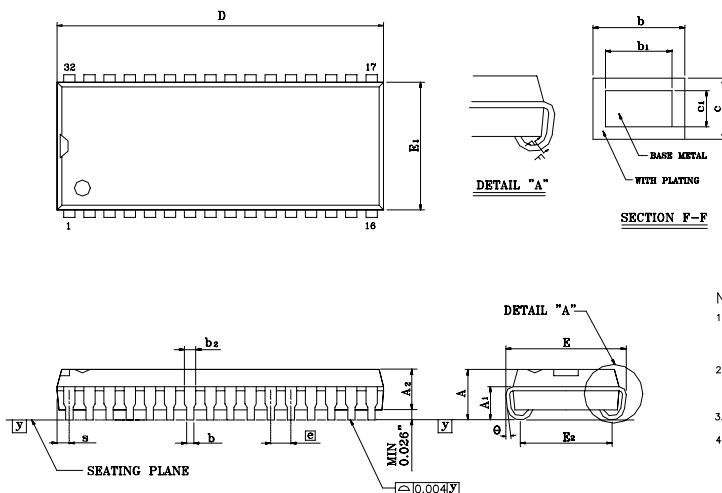
PDIP - 32

Symbol	Dimension in inch			Dimension in mm		
	Min	Nom	Max	Min	Nom	Max
A	0.128	0.132	0.140	3.25	3.35	3.56
A ₁	0.082	—	—	2.08	—	—
A ₂	0.095	0.100	0.105	2.41	2.54	2.67
b	0.016	0.018	0.020	0.41	0.46	0.51
b ₂	0.026	0.028	0.032	0.66	0.71	0.81
c	0.006	0.008	0.012	0.15	0.20	0.30
D	0.820	0.825	0.830	20.83	20.96	21.08
E	0.330	0.335	0.340	8.39	8.51	8.63
E ₁	0.295	0.300	0.305	7.49	7.62	7.75
E ₂	0.260	0.267	0.274	6.61	6.78	6.96
⊖	—	0.050	—	—	1.27	—
S	—	—	0.048	—	—	1.22
γ	—	—	0.004	—	—	0.10
⊖	-5°	2°	6°	-5°	2°	6°

Note:

- DIMENSION D DOES NOT INCLUDE MOLD FLASH, THE BAR BURRS, AND GATE BURRS, BUT MOLD MISMATCH IS INCLUDED. MOLD FLASH, THE BAR BURRS, AND GATE BURRS SHALL NOT EXCEED .006" PER END. DIMENSION E₁ DOES NOT INCLUDE INTERLEAD FLASH. INTERLEAD FLASH SHALL NOT EXCEED .010" PER SIDE.
- DIMENSIONS D AND E₁ ARE DETERMINED AT THE OUTERMOST EXTREMES OF THE PLASTIC BODY EXCLUSIVE OF MOLD FLASH, THE BAR BURRS, GATE BURRS AND INTERLEAD FLASH, BUT INCLUDING ANY MISMATCH BETWEEN THE TOP AND BOTTOM OF THE PLASTIC BODY.
- DIMENSION S INCLUDES MOLD PROTRUSION, MISMATCH AND SUPPORTING BAR BURRS.
- DIMENSION b₂ DOES NOT INCLUDE DAMBAR PROTRUSION OR INTRUSION. THE DAMBAR PROTRUSION(S) SHALL NOT CAUSE THE b₂ DIMENSION TO BE GREATER THAN .037" THE DAMBAR INTRUSION(S) SHALL NOT CAUSE THE b₂ DIMENSION TO BE SMALLER THAN .025"

SOJ - 32

REVISION HISTORY

Revision	Description	Date	Note
2.2	2001 Data Sheet release	Apr. 15, 2001	