

## Features

- Operating voltage: 5V~12V
- Drives two N-Channel MOSFETs
- Simple single-loop control design
  - Voltage-mode PWM control
- Fast transient response
  - High-bandwidth error amplifier
  - Full 0% to 100% duty ratio
- Excellent output voltage regulation
  - $\pm 1\%$  over line voltage and temperature
- 5 bit digital-to-analog output voltage selection
  - Wide range -1.3V to 3.5V
  - 0.1V binary steps from 2.1V to 3.5V
  - 0.05V binary steps from 1.3V to 2.05V
- Power-good output voltage monitor
- Over-voltage and over-current sensing element, uses MOSFET's  $r_{DS(ON)}$
- Small converter size
  - Constant frequency operation
  - 200kHz free-running oscillator programmable from 50kHz to over 1MHz

## Applications

- Power supply for Pentium<sup>TM</sup>, Pentium<sup>TM</sup> Pro, PowerPC<sup>TM</sup> and Alpha<sup>TM</sup> Microprocessors
- High-power 5V to 3.xVDC-DC regulators
- Low-voltage distributed power supplies

## General Description

The HT82P604B provides complete control and protection for a DC-DC converter optimized for high performance microprocessor applications. It is designed to drive two N-Channel MOSFETs in a synchronous-rectified buck topology. The HT82P604B integrates all of the control, output adjustment, monitoring and protection functions into a single package.

The output voltage of the converter is easily adjusted and precisely regulated. The HT82P604B includes a 5-input digital-to-analog converter (DAC) that adjusts the output voltage from 2.1V to 3.5V in 0.1V increments and from 1.3V to 2.05V in 0.05V steps. The precision reference and voltage-mode regulator hold the selected output voltage to within  $\pm 1\%$  over temperature and line voltage variations.

The HT82P604B provides simple, single feedback loop, voltage-mode control with fast tran-

sient response. It includes a 200kHz free-running triangle-wave oscillator that is adjustable from below 50kHz to over 1MHz. The error amplifier features a 15MHz gain-bandwidth product and 6V/ms slew rate which enables high converter bandwidth for fast transient performance. The resulting PWM duty ratio ranges from 0% to 100%.

The HT82P604B monitors the output voltage with a window comparator that tracks the DAC output and issues a Power Good signal when the output is within  $\pm 10\%$ . The HT82P604B protects against over-current conditions by inhibiting PWM operation. Built-in over-voltage protection triggers an external SCR to crowbar the input supply. The HT82P604B monitors the current by using the  $r_{DS(ON)}$  of the upper MOSFET which eliminates the need for a current sensing resistor.

Pin Assignment

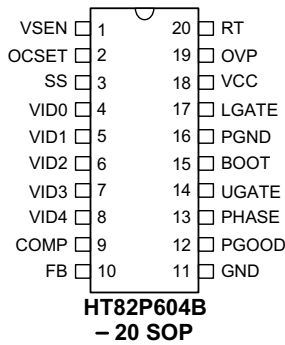

Pin Description

Pin No.	Pin Name	I/O	Description
1	VSEN	I	This pin is connected to the converters output voltage. The PGOOD and OVP comparator circuits use this signal to report output voltage status and for overvoltage protection.
2	OCSET	I	Connect a resistor ( $R_{OCSET}$ ) from this pin to the drain of the upper MOSFET. $R_{OCSET}$ , an internal 200mA current source ( $I_{OCS}$ ), and the upper MOSFET on-resistance ( $r_{DS(ON)}$ ) set the converter over-current (OC) trip point. $I_{PEAK} = \frac{I_{OCS} \times R_{OCSET}}{r_{DS(ON)}}$ An over-current trip cycles the soft-start function.
3	SS	O	Connect a capacitor from this pin to ground. This capacitor, along with an internal 10µA current source, sets the soft-start interval of the converter.
4~8	VID0~4	I	VID0-4 are the input pins to the 5-bit DAC. The states of these five pins program the internal voltage reference (DACOUT). The level of DACOUT sets the converter output voltage. It also sets the PGOOD and OVP thresholds. Table 1 specifies DACOUT for the 32 combinations of DAC inputs.
9, 10	COMP, FB	I	COMP and FB are the available external pins of the error amplifier. The FB pin is the inverting input of the error amplifier and the COMP pin is the error amplifier output. These pins are used to compensate the voltage-control feedback loop of the converter.
11	GND	P	Signal ground for the IC. All voltage levels are measured with respect to this pin.

Pin No.	Pin Name	I/O	Description
12	PGOOD	O	PGOOD is an open collector output used to indicate the status of the converter output voltage. This pin is pulled low when the converter output is not within $\pm 10\%$ of the DACOUT reference voltage. Exception to this behavior is the '11111' VID pin combination which disables the converter; in this case, PGOOD asserts a high level.
13	PHASE	O	Connect the PHASE pin to the upper MOSFET source. This pin is used to monitor the voltage drop across the MOSFET for over-current protection. This pin also provides the return path for the upper gate drive.
14	UGATE	O	Connect UGATE to the upper MOSFET gate. This pin provides the gate drive for the upper MOSFET.
15	BOOT	I	This pin provides bias voltage to the upper MOSFET driver. A bootstrap circuit may be used to create a BOOT voltage suitable to drive a standard N-Channel MOSFET.
16	PGND	P	This is the power ground connection. Tie the lower MOSFET source to this pin.
17	LGATE	O	Connect LGATE to the lower MOSFET gate. This pin provides the gate drive for the lower MOSFET.
18	VCC	P	Provide a 12V bias supply for the chip to this pin.
19	OVP	O	The OVP pin can be used to drive an external SCR in the event of an overvoltage condition.
20	RT	I	<p>This pin provides oscillator switching frequency adjustment. By placing a resistor (<math>R_T</math>) from this pin to GND, the nominal 200kHz switching frequency is increased.</p> $F_S \approx 200\text{kHz} + \frac{5 \times 10^6}{R_T (\text{k}\Omega)} (R_T \text{ to GND})$ <p>Conversely, connecting a pull-up resistor (<math>R_T</math>) from this pin to VCC reduces the switching frequency.</p> $F_S \approx 200\text{kHz} + \frac{4 \times 10^7}{R_T (\text{k}\Omega)} (R_T \text{ to 12V})$

### Absolute Maximum Ratings

Supply Voltage ..... +15V      Storage Temperature .....  $-50^\circ\text{C}$  to  $125^\circ\text{C}$   
 Input Voltage ..... GND-0.3 to  $V_{CC}+0.3\text{V}$       Operating Temperature .....  $-20^\circ\text{C}$  to  $75^\circ\text{C}$

Note: These are stress ratings only. Stresses exceeding the range specified under "Absolute Maximum Ratings" may cause substantial damage to the device. Functional operation of this device at other conditions beyond those listed in the specification is not implied and prolonged exposure to extreme conditions may affect device reliability.

**Electrical Characteristics**

Symbol	Parameter	Test Conditions		Min.	Typ.	Max.	Unit
		V <sub>CC</sub>	Conditions				
<b>V<sub>CC</sub> Supply Current</b>							
I <sub>CC</sub>	Nominal Supply	12V	Ugate and Lgate Open	—	5	—	mA
<b>Power-On Reset</b>							
	Rising V <sub>CC</sub> Threshold	12V	V <sub>OCSET</sub> =4.5V	—	—	10.4	V
	Falling V <sub>CC</sub> Threshold	12V	V <sub>OCSET</sub> =4.5V	8.2	—	—	V
	Rising V <sub>OCSET</sub> Threshold	12V		—	1.26	—	V
<b>Oscillator</b>							
	Free Running Frequency	12V	RT=Open	185	200	215	kHz
	Total Variation	12V	6kΩ<RT to GND<200kΩ	-15	—	+15	%
ΔV <sub>OSC</sub>	Ramp Amplitude	12V	RT=Open	—	1.9	—	V <sub>P-P</sub>
<b>Reference and DAC</b>							
	DACOUT Voltage Accuracy	12V		-1.0	—	+1.0	%
<b>ERROR Amplifier</b>							
	DC Gain	12V		—	88	—	dB
GBW	Gain-Bandwidth Product	12V		—	15	—	MHz
SR	Slew Rate	12V	COMP=10pF	—	6	—	V/μs
<b>Gate Drivers</b>							
I <sub>UGATE</sub>	Upper Gate Source	12V	V <sub>BOOT</sub> -V <sub>PHASE</sub> =12V, V <sub>UGATE</sub> =6V	350	500	—	mA
R <sub>UGATE</sub>	Upper Gate Sink	12V	I <sub>LGATE</sub> =0.3A	—	5.5	10	Ω
I <sub>LGATE</sub>	Lower Gate Source	12V	V <sub>CC</sub> =12V, V <sub>LGATE</sub> =6V	300	450	—	mA
R <sub>LGATE</sub>	Lower Gate Sink	12V	I <sub>LGATE</sub> =0.3V	—	3.5	6.5	Ω
<b>Protection</b>							
	Over-Voltage Trip (V <sub>SEN</sub> /DACOUT)	12V		—	115	120	%
I <sub>OCSET</sub>	OCSET Current Source	12V	V <sub>OCSET</sub> =4.5V <sub>DC</sub>	170	200	230	μA
I <sub>OVP</sub>	OVP Sourcing Current	12V	V <sub>SEN</sub> =5.5, V <sub>OVP</sub> =0V	60	—	—	mA
I <sub>SS</sub>	Soft Start Current	12V		—	10	—	μA
<b>Power Good</b>							
	Upper Threshold (V <sub>SEN</sub> /DACOUT)	12V	V <sub>SEN</sub> Rising	106	—	111	%

Symbol	Parameter	Test Conditions		Min.	Typ.	Max.	Unit
		V <sub>CC</sub>	Conditions				
	Lower Threshold (V <sub>SEN</sub> /DACOUT)	12V	V <sub>SEN</sub> Falling	89	—	94	%
	Hysteresis (V <sub>SEN</sub> /DACOUT)	12V	Upper and Lower Threshold	—	2	—	%
V <sub>PGOOD</sub>	PGOOD Voltage Low	12V	I <sub>PGOOD</sub> =-5mA	—	0.5	—	V

## Functional Description

### Output voltage program

The output voltage of a HT82P604B converter is programmed to discrete levels between 1.3V and 3.5V. The voltage identification (VID) pins program an internal voltage reference (DACOUT) with a 5-bit digital-to-analog converter (DAC). The level of DACOUT also sets the PGOOD and OVP thresholds. Table 1 specifies the DACOUT voltage for the 32 combinations of open or short connections on the VID pins. The output voltage should not be adjusted while the converter is delivering power. Remove input power before changing the output voltage. Adjusting the output voltage during operation could toggle the PGOOD signal and exercise the overvoltage protection.

Pin Name					Nominal Output Voltage Dacout
VID4	VID3	VID2	VID1	VID0	
0	1	1	1	1	1.30
0	1	1	1	0	1.35
0	1	1	0	1	1.40
0	1	1	0	0	1.45
0	1	0	1	1	1.50
0	1	0	1	0	1.55
0	1	0	0	1	1.60
0	1	0	0	0	1.65
0	0	1	1	1	1.70
0	0	1	1	0	1.75
0	0	1	0	1	1.80

Pin Name					Nominal Output Voltage Dacout
VID4	VID3	VID2	VID1	VID0	
0	0	1	0	0	1.85
0	0	0	1	1	1.90
0	0	0	1	0	1.95
0	0	0	0	1	2.00
0	0	0	0	0	2.05
1	1	1	1	1	0
1	1	1	1	0	2.1
1	1	1	0	1	2.2
1	1	1	0	0	2.3
1	1	0	1	1	2.4
1	1	0	1	0	2.5
1	1	0	0	1	2.6
1	1	0	0	0	2.7
1	0	1	1	1	2.8
1	0	1	1	0	2.9
1	0	1	0	1	3.0
1	0	1	0	0	3.1
1	0	0	1	1	3.2
1	0	0	1	0	3.3
1	0	0	0	1	3.4
1	0	0	0	0	3.5

Note: 0=connected to GND or VSS, 1=OPEN

Table 1 Output voltage program

Application Circuits

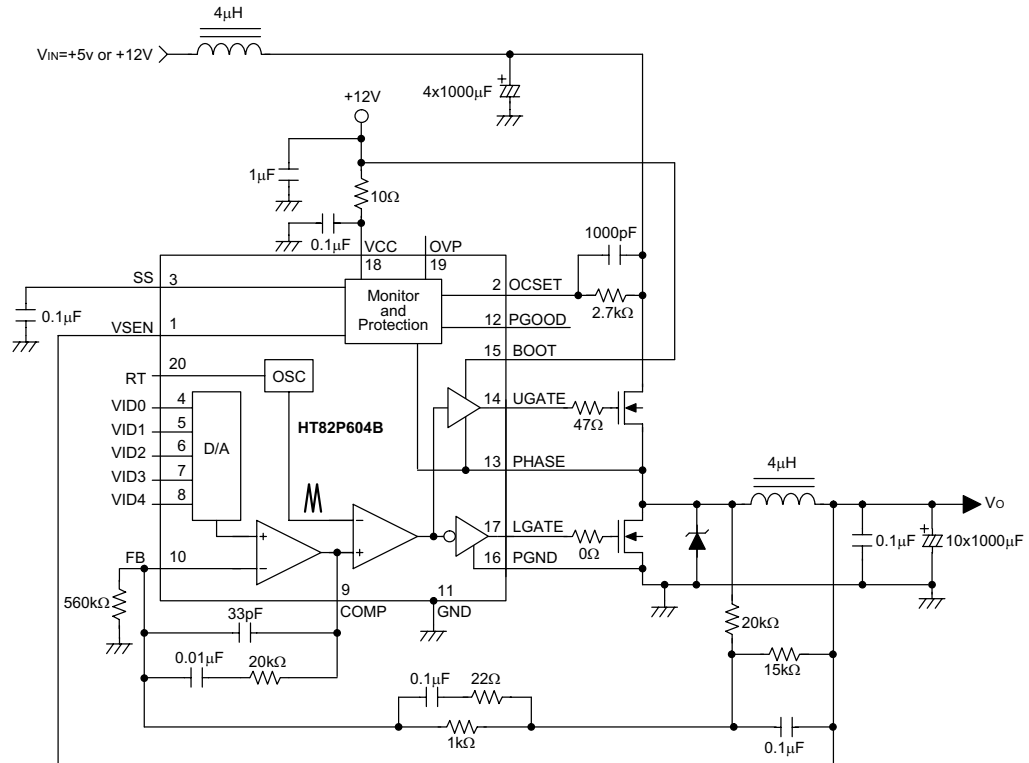

**Holtek Semiconductor Inc. (Headquarters)**

No.3 Creation Rd. II, Science-based Industrial Park, Hsinchu, Taiwan, R.O.C.  
Tel: 886-3-563-1999  
Fax: 886-3-563-1189

**Holtek Semiconductor Inc. (Taipei Office)**

5F, No.576, Sec.7 Chung Hsiao E. Rd., Taipei, Taiwan, R.O.C.  
Tel: 886-2-2782-9635  
Fax: 886-2-2782-9636  
Fax: 886-2-2782-7128 (International sales hotline)

**Holtek Semiconductor (Hong Kong) Ltd.**

RM.711, Tower 2, Cheung Sha Wan Plaza, 833 Cheung Sha Wan Rd., Kowloon, Hong Kong  
Tel: 852-2-745-8288  
Fax: 852-2-742-8657

Copyright © 2000 by HOLTEK SEMICONDUCTOR INC.

The information appearing in this Data Sheet is believed to be accurate at the time of publication. However, Holtek assumes no responsibility arising from the use of the specifications described. The applications mentioned herein are used solely for the purpose of illustration and Holtek makes no warranty or representation that such applications will be suitable without further modification, nor recommends the use of its products for application that may present a risk to human life due to malfunction or otherwise. Holtek reserves the right to alter its products without prior notification. For the most up-to-date information, please visit our web site at <http://www.holtek.com.tw>.