

Feature

- Microsoft Intelli mouse compatible
- IBM PS/2 mouse and Microsoft serial mouse compatible
- Support rolling buttons in serial and PS/2 mouse mode
- Supports three buttons (RB, Ro, LB) and three axis (X, Y, Z) inputs
- Fit Plug and Play com port device specification
- Z axis can support two kinds of scroller input (optomechanical and mechanical)
- 2MHz operating frequency with external resonator
- 18-pin DIP package

General Description

The HT82M33A is a Plug and Play 2-in-1 (Serial and PS/2) 3D mouse controller. It is compatible with Microsoft Intelli mouse. The Z axis can

support two kinds of scroller input, namely; optomechanical and mechanical.

Pin Assignment

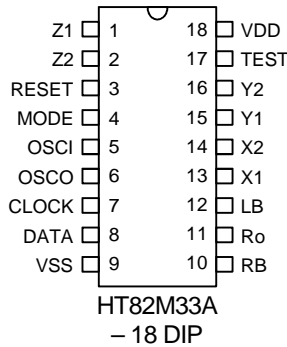

Pin Description

Pin No.	Pin Name	I/O	Description
1,2	Z1, Z2	I	“Zaxis input”: Supports two kinds of scroller input, optomechanical and mechanical
3	RESET	I	“Reset input”: Resets internal circuit by input low, normal is connected to high by internal pull-high resistor (120k Ω).
4	MODE	I	“MS or PS/2 mode selection”: Low for PS/2 mouse, high for MS mouse. The MS PnP mouse ID code sure will appear when this pin rise from low to high. Normal is connected to low by internal pull-low resistor (60k Ω). The mode input transition voltage is 2.0V.
5	OSCI	I	“Oscillator in”: Connect to 2MHz crystal or resonator
6	OSCO	O	“Oscillator out”: Connect to 2MHz crystal or resonator
7	CLOCK	I/O	“CLOCK I/O”: PS/2 mouse CLOCK line. NMOS open drain output with 7.5k Ω pull-high resistor.
8	DATA	I/O	“DATA/RXD I/O” PS/2 mouse DATA line or MS mouse $\overline{\text{RXD}}$ output. NMOS open drain output with 7.5k Ω pull-high resistor.
9	VSS	I	Negative power pin
10~12	RB, Ro, LB	I	“Right Button”: Normal pull-high (45k Ω), press connect to low. “Rolling Button” : Normal pull-high (45k Ω), press connect to low. “Left Button”: Normal pull-high (45k Ω), press connect to low.
13~16	X1, X2, Y1, Y2	I	“X/Y axis input”: Auto level detecting input. Any signal over 0.6V V_{PP} is acceptable but the $+V_P$ cannot be over 2.5V
17	TEST	I	“IC test pin”: with built-in pull-low resistor. In normal operation this is connected to VSS or floating. While the pin is connected to VDD, this will provide the H/W test. The chip will accord the state of the RB pin, to switch the X1/Y1 and X2/Y2 via the PIN Ro and LB output.
18	VDD	I	Positive power pin.

Absolute Maximum Ratings

Supply Voltage-0.3V to 6.5V Storage Temperature -50°C to 125°C
 Input Voltage..... V_{SS} -0.3V to V_{DD} +0.3V Operating Temperature..... -25°C to 70°C

Note: These are stress ratings only. Stresses exceeding the range specified under “Absolute Maximum Ratings” may cause substantial damage to the device. Functional operation of this device at other conditions beyond those listed in the specification is not implied and prolonged exposure to extreme conditions may affect device reliability.

D.C. Characteristics

Ta=25°C

Symbol	Parameter	Test Conditions		Min.	Typ.	Max.	Unit
		V _{DD}	Conditions				
V _{DD}	Operating Voltage	—	—	4.5	5.0	5.5	V
I _{SD}	Standby Voltage	5V	RESET=0V, no load	—	—	1.5	mA
I _{DD}	Operating Current	5V	Freq=2MHz, RESET=5V, no load	—	2.2	3	mA
V _{IL}	Input Low Voltage (RB, Ro, LB, TEST)	5V	—	0	—	1.5	V
V _{IH}	Input High Voltage (RB, Ro, LB, TEST)	5V	—	3.5	—	5.0	V
V _{IL1}	Input Low Voltage (Z1, Z2)	5V	—	0	—	1.0	V
V _{IH1}	Input High Voltage (Z1, Z2)	5V	—	1.2	—	5.0	V
V _{IL2}	Input Low Voltage (CLOCK, DATA)	5V	—	0	—	1.2	V
V _{IH2}	Input High Voltage (CLOCK, DATA)	5V	—	2.1	—	5.0	V
V _{IL3}	Input Low Voltage (RESET)	5V	—	0	—	1.8	V
V _{IH3}	Input High Voltage (RESET)	5V	—	3.3	—	5.0	V
I _{OL}	Output Sink Current (CLOCK, DATA)	5V	V _{IL} =0.5V	6	—	—	mA
I _{OH}	Output Source Current (CLOCK, DATA)	5V	V _{IH} =4.5V	—	2	—	mA
R _L	Pull-low Resistor (Z1, Z2)	5V	V _{IH} =5V, V _{SS} =0V	—	600	—	kΩ
R _{L1}	Pull-low Resistor (TEST)	5V	V _{IH} =5V, V _{SS} =0V	10	17	30	kΩ
R _{L2}	Pull-low Resistor (RB, Ro, LB)	5V	V _{IH} =5V, V _{SS} =0V	33	45	56	kΩ
R _{L3}	Pull-low Resistor (MODE)	5V	V _{IH} =5V, V _{SS} =0V	48	60	72	kΩ
R _H	Pull-high Resistor (CLOCK, DATA)	5V	V _{IL} =0V	5	7.5	10	kΩ
R _{H1}	Pull-high Resistor (RESET)	5V	V _{IL} =0V	100	125	150	kΩ

A.C. Characteristics

Ta=25°C

Symbol	Parameter	Test Conditions		Min.	Typ.	Max.	Unit
		VDD	Conditions				
f _P	X,Y Input Frequency	5V	—	—	—	8.2	kHz
f _N	X,Y Operating Frequency	5V	—	—	—	8	kHz
t _{KD}	Key Debounce	5V	—	—	52	—	ms
t _{MS}	Transmission Time	5V	Serial mouse mode	—	33	—	ms
t _S	Start Bit Time	5V	Serial mouse mode	—	0.85	—	ms
t _D	Data Bit Time	5V	Serial mouse mode	—	0.82	—	ms
t _P	Stop Bit Time	5V	Serial mouse mode	—	0.82	—	ms
t _{RD}	ID Code Delay	5V	Serial mouse mode	—	15	—	ms
t _R	Rising Edge Crossed Width	5V	—	50	—	—	μs
t _F	Falling Edge Crossed Width	5V	—	50	—	—	μs
t _{RESET}	Reset Low Pulse Width	5V	—	1	—	—	μs
F _{OSC}	System Clock	5V	Crystal Oscillator	—	2.0	—	MHz

Functional Description

Serial mouse

- Data format of 3D Serial mouse
1200 bps, N, 7, 1, single direction

Bit No.	6	5	4	3	2	1	0
1st word	1	L	R	Y7	Y6	X7	X6
2nd word	0	X5	X4	X3	X2	X1	X0
3rd word	0	Y5	Y4	Y3	Y2	Y1	Y0
4th word	0	0	Ro	Z3	Z2	Z1	Z0

Notes: X7~X0: $-128 < X < 127$, (2's complement)

Y7~Y0: $-128 < Y < 127$, (2's complement)

Z3~Z0: $-8 < Z < 7$, (2's complement)

Button status: 1=pressed, 0=released

- Win 95 Plug and Play ID fields

For compatibility with the old serial mouse drivers, all mouse-compatible pointing devices must restrict themselves to a 6-bit character set, for all fields except the mouse ID. Therefore, all old-mouse-compatible strings are limited to values of 0x00 to 0x3f; character strings are ASCII codes from 0x20 to 0x5f, offset by subtracting 0x20.

Microsoft mode

Field Name	Size	Field Data	Description
Old Mouse ID	1	4D	Identifies a mouse for old Microsoft mode drivers
Compatible with Microsoft Intelli mouse	5	5A, 40, 00, 00, 00	"Z@"
Begin PnP	1	08	"(" indicates PnP IDs will follow
PnP Rev	2	01, 24	Identifiers PnP version 1.0
EISA ID	3	28, 34, 2B	"HTK" (A mouse company)
Product ID	4	10, 10, 10, 11	"0001" (Unique product identifier)
Extended	1	3C	"\"
Class Name	6	3C, 2D, 2F, 35, 33, 25	"\MOUSE" fits a defined Windows 95 class name
Driver ID	8	3C, 30, 2E, 30, 10, 26, 10, 21	"\PNP0F0A" fits a defined Windows 95 Microsoft mouse compatible ID
Checksum	2	19, 10	Checksum of all characters from begin PnP to End PnP, exclusive of the checksum characters themselves.
End PnP	1	09	") indicates PnP IDs complete

- Encourage the Plug and Play mouse ID

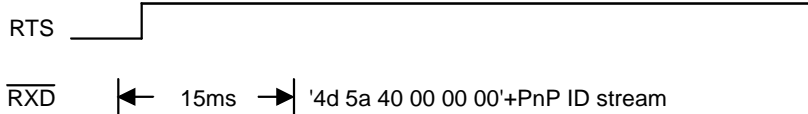

PS/2 mouse

- PS/2 status byte bit

7:RESERVED
 6: 0=STREAM MODE, 1= REMOTE MODE
 5: 0=DISABLED, 1=ENABLED
 4: 0=SCALING 1:1, 1= SCALING 2:1
 3: 1=WRAP MODE, 0=STREAM or REMOTE (different from IBM spec.)
 2: 1= LEFT BUTTON PRESSED
 1: 1= MIDDLE BUTTON PRESSED
 0: 1= RIGHT BUTTON PRESSED

- Standard PS/2 data format

Variable rps, O, 8, 1, bidirectional, synchronous

Bit No.	7	6	5	4	3	2	1	0
1st word	YV	XV	YS	XS	1	M	R	L
2nd word	X7	X6	X5	X4	X3	X2	X1	X0
3rd word	Y7	Y6	Y5	Y4	Y3	Y2	Y1	Y0

- Data format for 3D PS/2

Variable rps, O, 8, 1, bidirectional, synchronous

Bit No.	7	6	5	4	3	2	1	0
1st word	YV	XV	YS	XS	1	Ro	R	L
2nd word	X7	X6	X5	X4	X3	X2	X1	X0
3rd word	Y7	Y6	Y5	Y4	Y3	Y2	Y1	Y0
4th word	Z7	Z6	Z5	Z4	Z3	Z2	Z1	Z0

The x/y data report is 9-bit 2's complement
 The z data report is 8-bit 2's complement
 X move right is positive, move left is negative
 Y move up is positive, move down is negative
 Z rolling toward user is positive, else is negative
 Button status : 1=pressed, 0=released

- Mouse mode changes between Standard and 3D PS/2 mode

Sending the commands in the following sequence will set the mouse to 3D PS/2 mode.

Command	Response From Mouse
F3h	FAh
C8h	FAh
F3h	FAh
64h	FAh
F3h	FAh
50h	FAh
F2h	FAh, 03h

* Any time the PC sends a reset "FFh" command to the mouse, it will reset the mouse to Standard PS/2 mode.

* After power on reset is initiated, the mouse is set to Standard PS/2 mode.

Timing Diagrams

X,Y,Z input

- X,Y Axis Photo-coupler crossed width

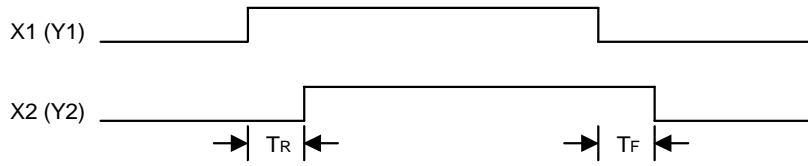

- Z Axis counting

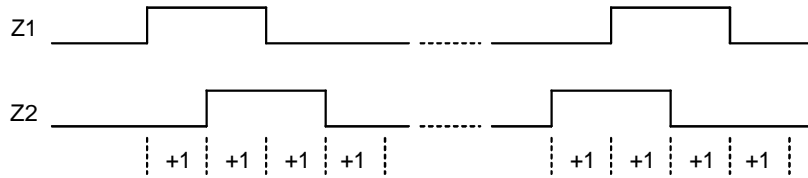

Serial mouse

- Word structure

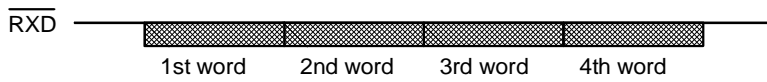

- Key output

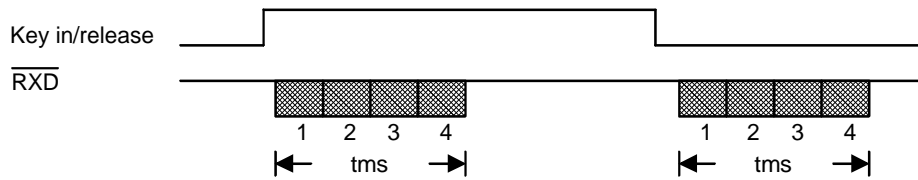

- Bit structure

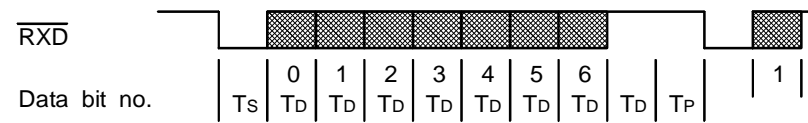

• Encourage the Plug and Play ID

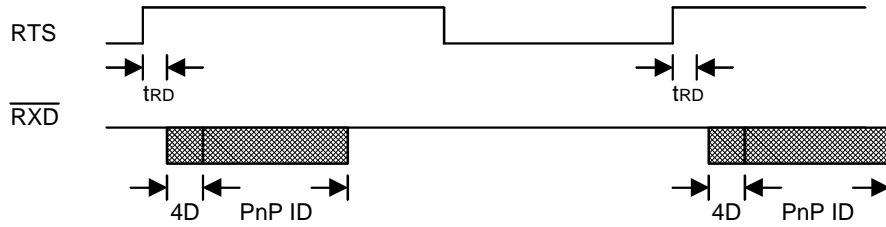

• PnP COM Enumerator timing

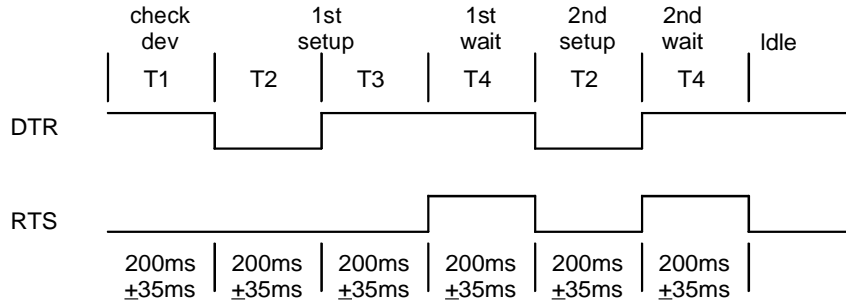

- T1: Interval to hold DTR high while waiting for DSR
- T2: Interval for external device to power down or detect the port state
- T3: DTR-RTS enumerator signature delay
- T4: Maximum interval to wait for DSR and/or first received character
- T5: PnP COM ID per/character timeout 200ms (not shown)
- T6: PnP COM ID EndPnP timeout 2.2 seconds (not shown)
- T7: Disconnect verification timeout 5 seconds (not shown)

PS/2 mouse

• Data output

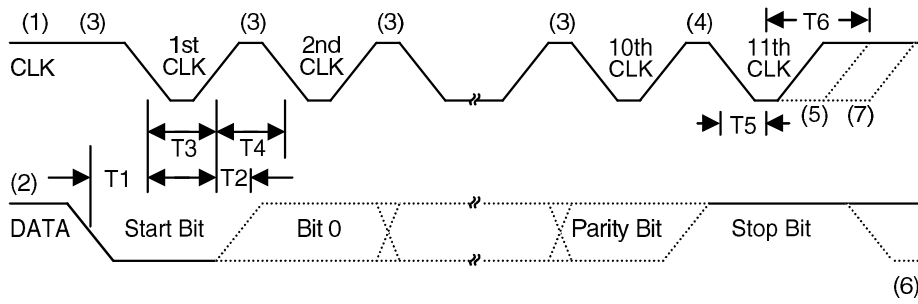

Timing Parameter	Min./Max.
T1 DATA transition to the falling edge of CLOCK	5/25 μ sec
T2 Rising edge of CLOCK to DATA transition	5/T4-5 μ sec
T3 Duration of CLOCK inactive	30/50 μ sec
T4 Duration of CLOCK active	30/50 μ sec
T5 Minimum time to MOUSE inhibit after clock 11	>0 μ sec
T6 Maximum time to MOUSE inhibit after clock 11 to ensure MOUSE does not start another transmission	<50 μ sec

• Data input

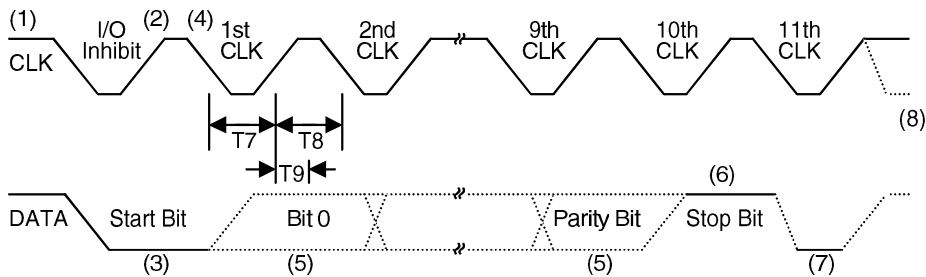

Timing Parameter	Min./Max.
T7 Duration of CLOCK low	30/50 μ sec
T8 Duration of CLOCK high	30/50 μ sec
T9 Time from low to high CLOCK transition to time when MOUSE samples DATA line	5/25 μ sec

Application Circuits

HT82M33A 3D 2 in1 mouse (This application circuit is for reference only)

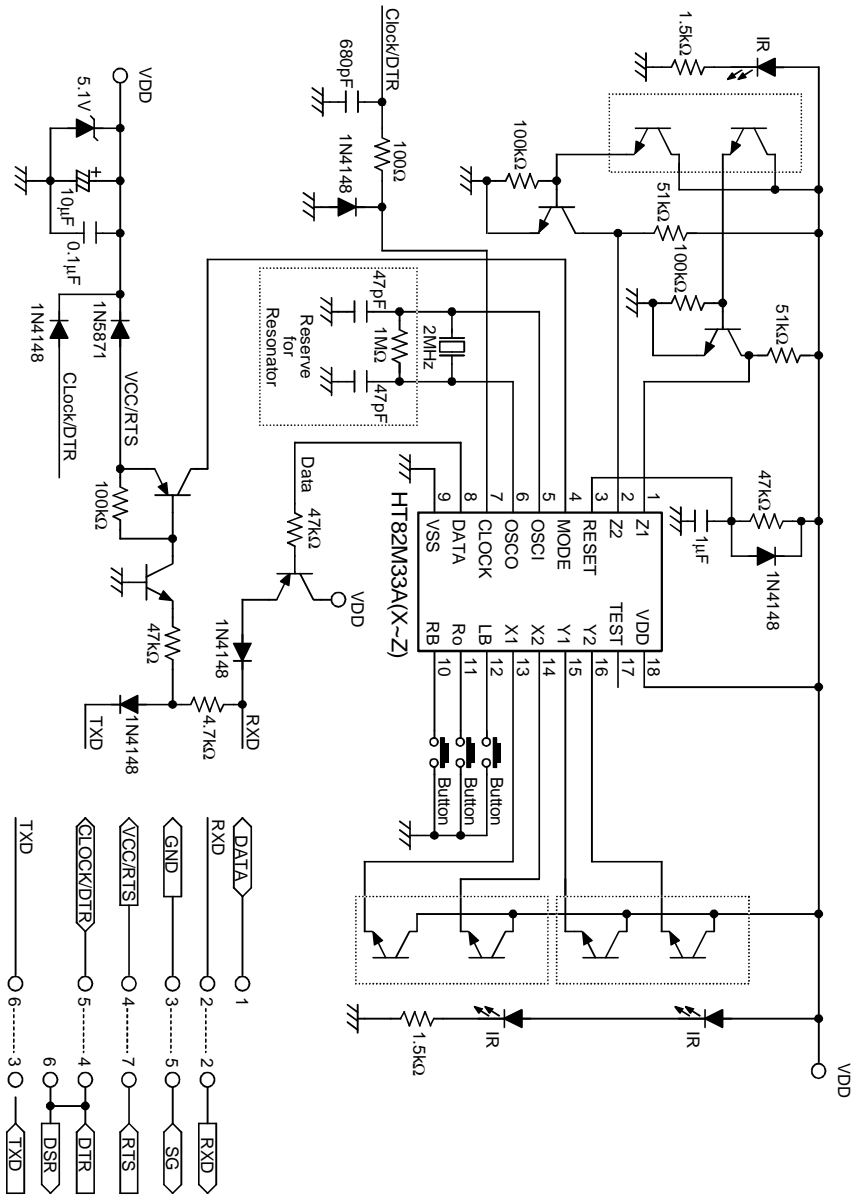

Notes: CLOCK & DATA is internal pull-high 10kΩ.
 OSCO & OSCI are build in R & C.
 Z1 & Z2 is internal pull-low 250kΩ.

HT82M33A 3D 2 in1 mouse (This application circuit is for reference only)

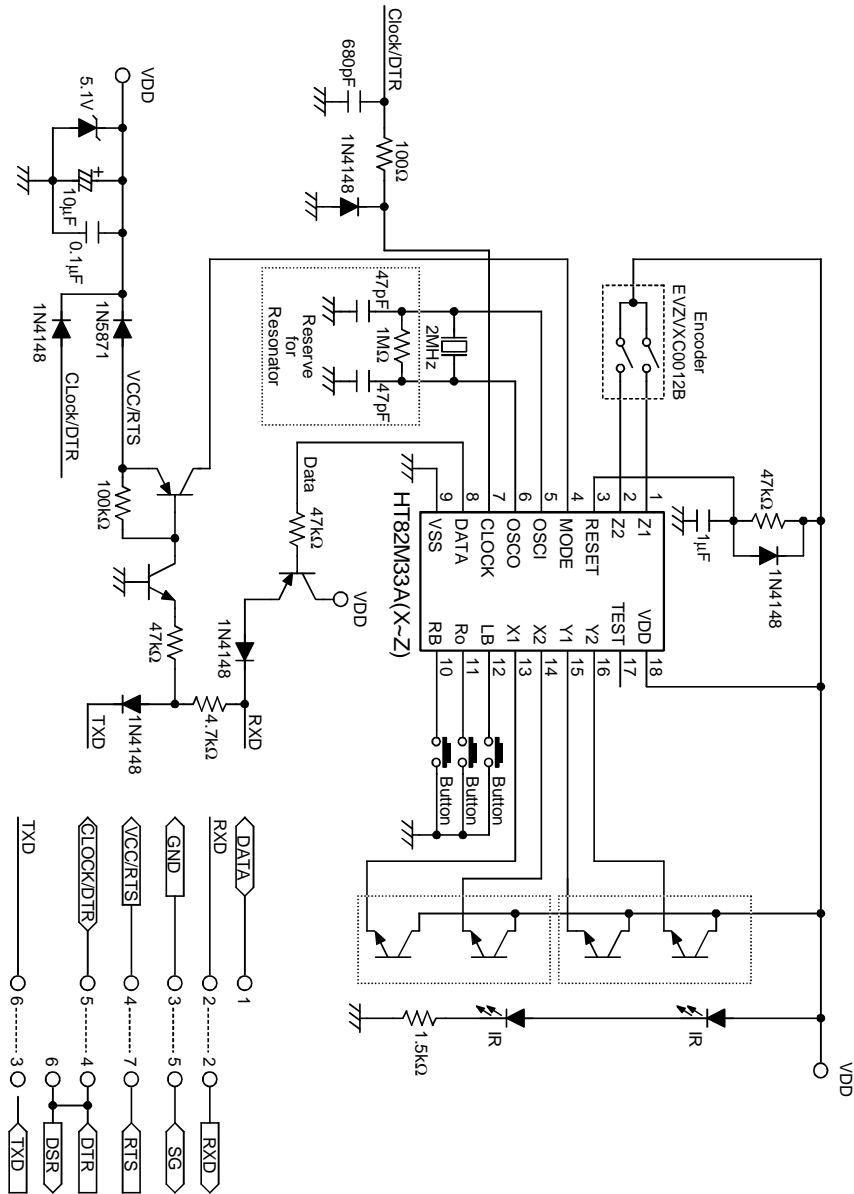

Notes: CLOCK & DATA is internal pull-high 10kΩ.
 OSCO & OSCO are build in R & C.
 Z1 & Z2 is internal pull-low 250kΩ.

HT82M33A 3D PS2 mouse (This application circuit is for reference only)

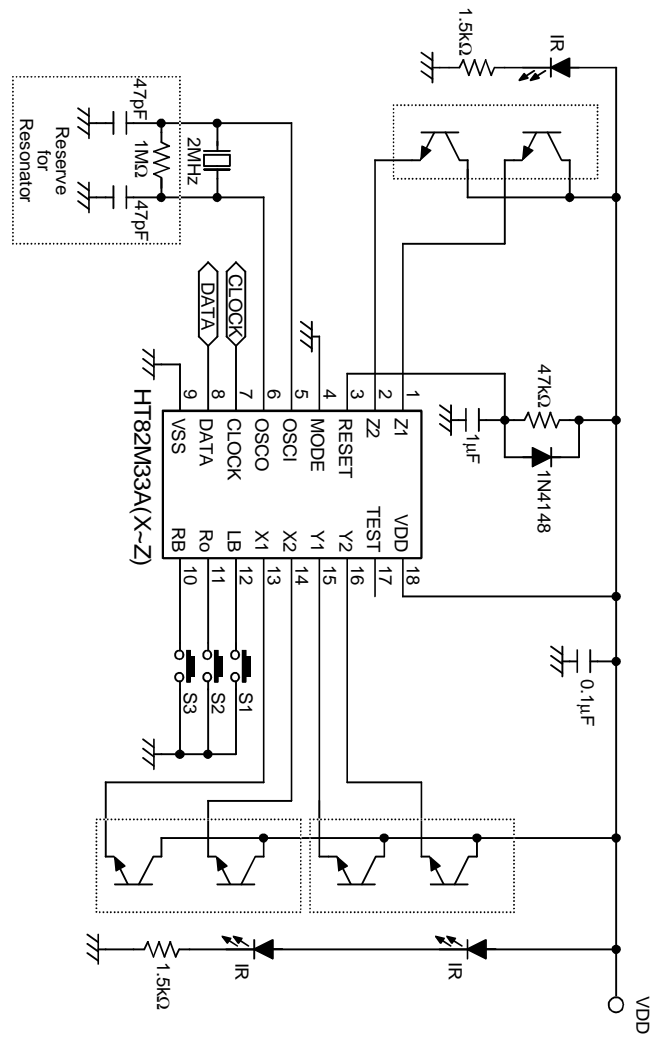

HT82M33A 3D PS2 mouse (This application circuit is for reference only)

