

Unipolar Driver ICs

SLA7020M SLA7021M WITH MOSFETs

■ Ratings

| Absolute maximum ratings | Motor supply Voltage | FET output breakdown voltage | Control voltage | TTL input voltage | Reference voltage | Output current | Power dissipation | Channel temperature | Storage temperature |
|--------------------------|----------------------|------------------------------|-----------------|-------------------|-------------------|----------------|-------------------|---------------------|---------------------|
| | (V) | (V) | (V) | (V) | (V) | (A) | (W) | (°C) | (°C) |
| Type No. | V _{CC} | V _{DS} | V _S | V _{IN} | V _{REF} | I _O | P _D | T _{ch} | T _{stg} |
| SLA7020M | 46 | 100 | 32 | 7 | 2 | 1.5 | 4.5 (No Fin) | 150 | -40 to +150 |
| SLA7021M | | | | | | 3 | | | |

■ Characteristics (1) DC Characteristics

| Electrical characteristics | Control current (mA) | | | Control voltage (V) | | | FET turn-on voltage (V) | | | FET drain leak current (mA) | | | TTL input current (μA) | | | TTL input current (mA) | | | TTL input voltage (OUT) (V) | | | TTL input voltage (V) | | | TTL input voltage (OUT) (V) | | | TTL input voltage (V) | | | | |
|----------------------------|----------------------|-----|-----|---------------------|-----|-----|--|-----|------|---|-----|-----|--|-----|-----|--|-----|------|-----------------------------|-----|-----|-------------------------|-----|-----|-----------------------------|-----|-----|-----------------------|-----|-----|--|-----|
| | V _S = 30V | | | | | | (7020M) I _D = 1A, V _S = 14V (7021M) I _D = 3A, V _S = 14V | | | V _{DSS} = 100V V _S = 30V | | | V _{IH} = 2.4V V _S = 30V | | | V _{IL} = 0.4V V _S = 30V | | | I _D = 1A | | | V _{DSS} = 100V | | | V _{DSS} = 100V | | | I _D = 1A | | | | |
| | I _S | | | V _S | | | V _{DS} | | | I _{DSS} | | | I _{IH} | | | I _{IL} | | | V _{IH} | | | V _{IL} | | | V _{IH} | | | V _{IL} | | | | |
| Type No. | min | typ | max | min | typ | max | min | typ | max | min | typ | max | min | typ | max | min | typ | max | min | typ | max | min | typ | max | min | typ | max | min | typ | max | | |
| SLA7020M | | | | | | | | | 0.6 | | | 4 | | | 40 | | | -0.8 | 2.0 | | | | | 0.8 | 2.0 | | | | | | | 0.8 |
| SLA7021M | 5.5 | 10 | 15 | 10 | 19 | 30 | | | 0.85 | | | | | | | | | | | | | | | | | | | | | | | |

(2) AC Characteristics

| Electrical characteristics | FET diode forward voltage (V) | | | Switching time (μs) | | | | | | | | | | | |
|----------------------------|--|-----|-----|---|-----|-----|------------------|-----|-----|----------------|-----|-----|-----|-----|-----|
| | (7020M) I _{SD} = 1A (7021M) I _{SD} = 3A | | | V _S = 24V I _D = 1A | | | | | | | | | | | |
| | V _{SD} | | | T _r | | | T _{stg} | | | T _f | | | | | |
| Type No. | min | typ | max | min | typ | max | min | typ | max | min | typ | max | min | typ | max |
| SLA7020M | | | 1.1 | | | | | | | | | | | | 0.1 |
| SLA7021M | | | 2.3 | | 0.5 | | | 0.7 | | | | | | | |

SLA7020M and SLA7021M

■ Block diagram

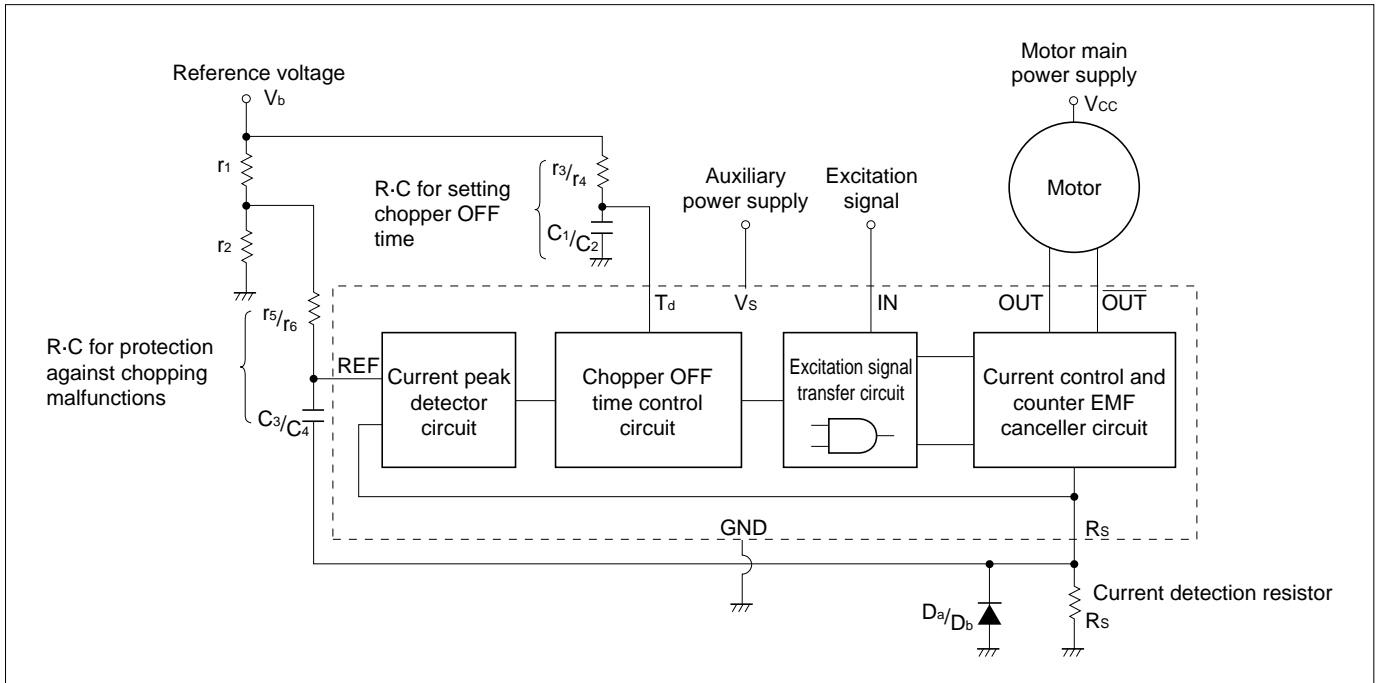

■ Internal circuit diagram (enclosed with chain line)

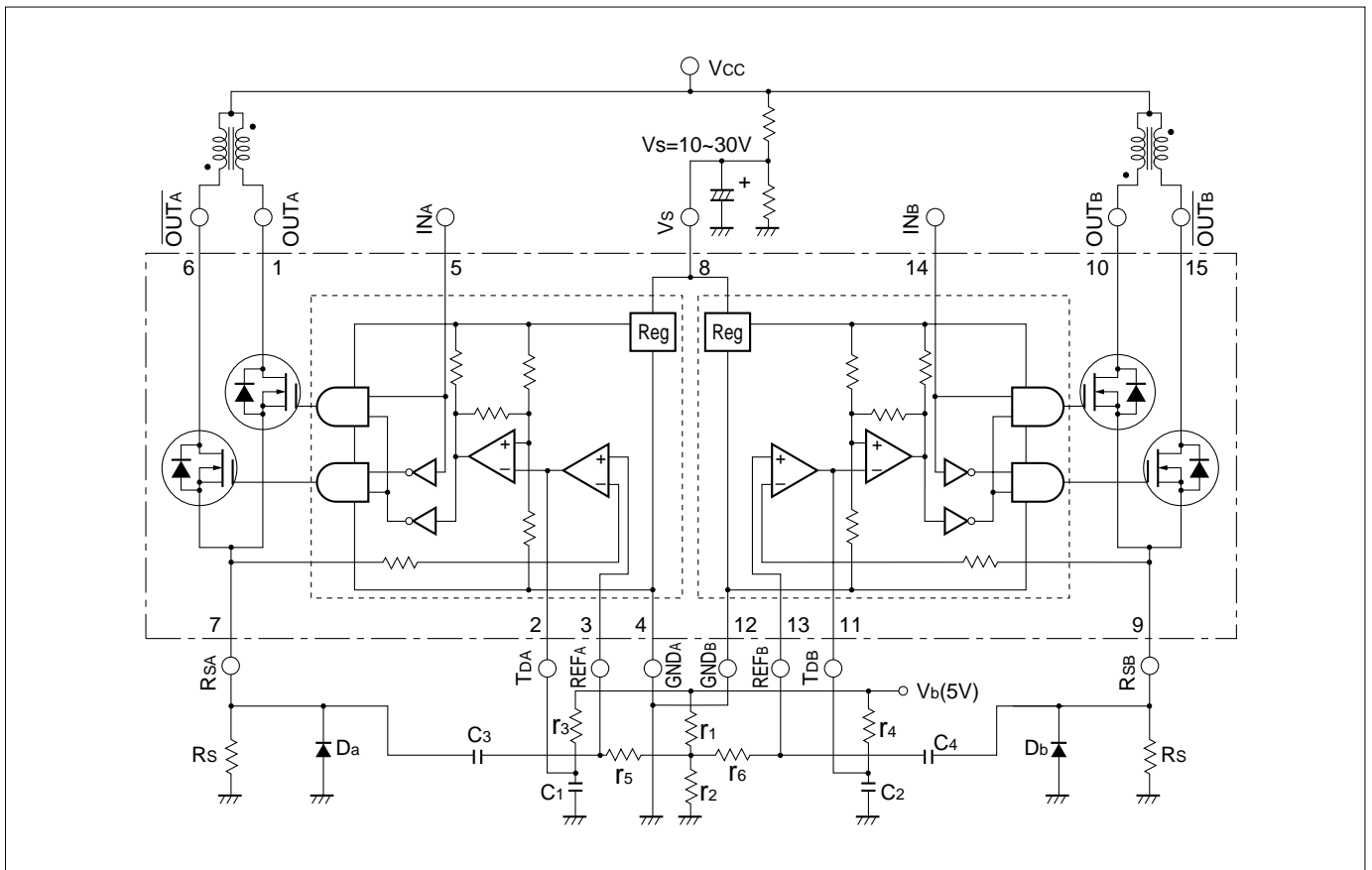

SLA7020M and SLA7021M

■ Diagram of standard external circuit (Recommended circuit constants)

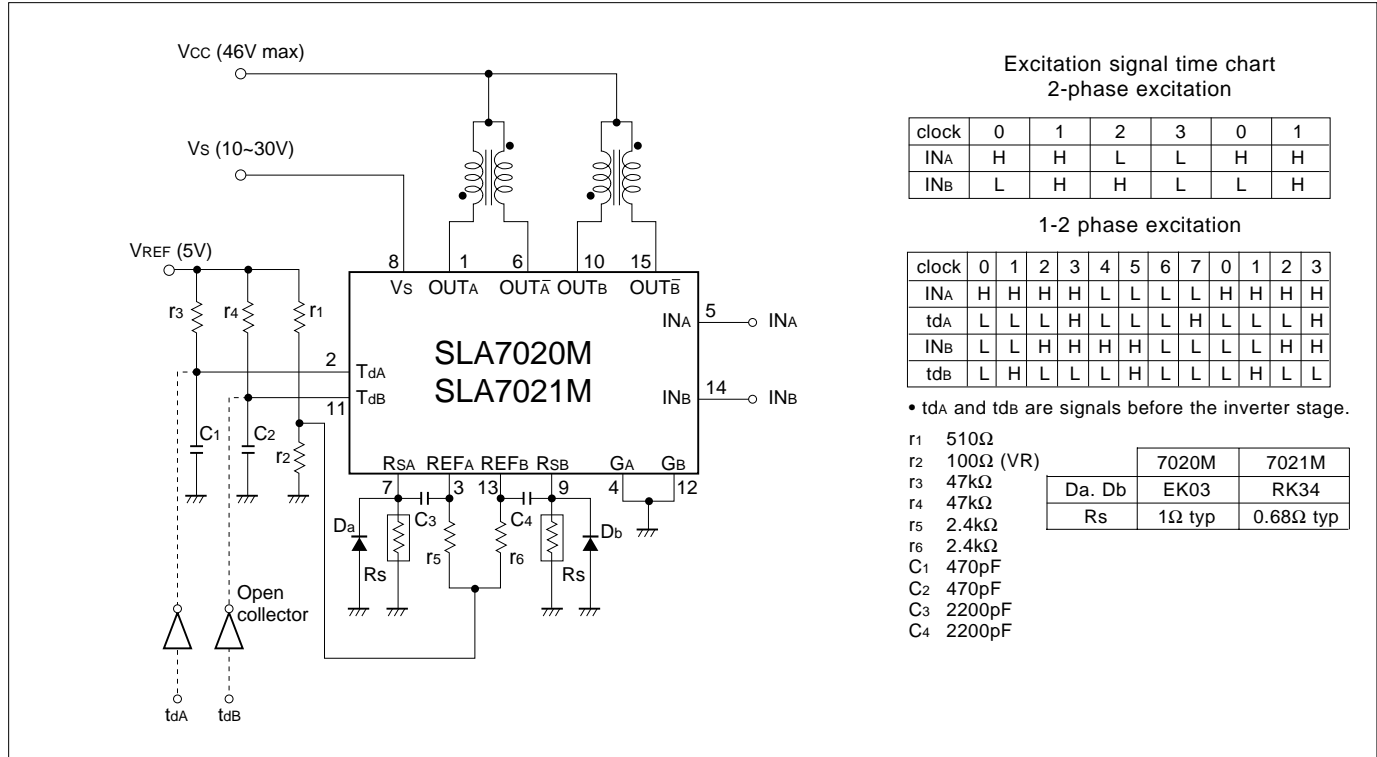

■ External dimensions

(Unit: mm)

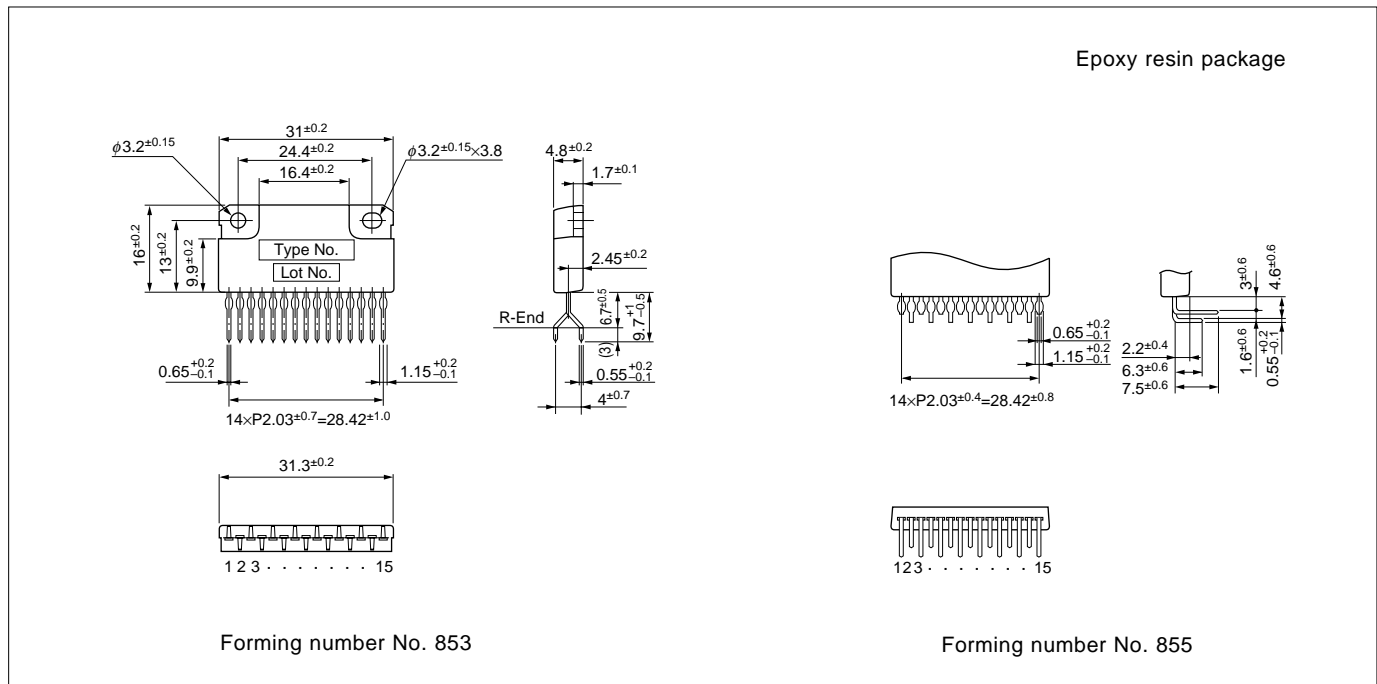

Application Note

■ Determining the output current

Fig. 1 shows the waveform of the output current (motor coil current). The method of determining the peak value (I_o) of the output current based on this waveform is shown below.

<Parameters for determining the output current I_o >

- V_b : Reference supply voltage
- r_1, r_2 : Voltage-divider resistors for the reference supply voltage
- R_s : Current detection resistor

(1) Normal rotation mode

I_o is determined as follows when current flows at the maximum level during motor rotation. See Fig. 2, 3 and 4.

$$I_o \doteq \frac{r_2}{r_1+r_2} \cdot \frac{V_b}{R_s} \dots\dots\dots \textcircled{1}$$

(2) Power down mode

The circuits in Fig. 5, 6 and 7 (r_x and T_r) are added in order to decrease the coil current. I_o is then determined as follows.

$$I_{OPD} \doteq \frac{1}{1 + \frac{r_1(r_2+r_x)}{r_2 \cdot r_x}} \cdot \frac{V_b}{R_s} \dots\dots\dots \textcircled{2}$$

To determine r_x , equation ② can be modified to obtain equation ③.

$$r_x \doteq \frac{1}{\frac{1}{r_1} \left(\frac{V_b}{R_s \cdot I_{OPD}} - 1 \right) - \frac{1}{r_2}} \dots\dots\dots \textcircled{3}$$

Fig. 3 Circuit for fixing the coil current

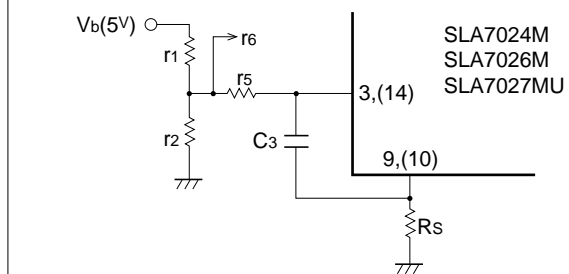

Fig. 4 Circuit for fixing the coil current

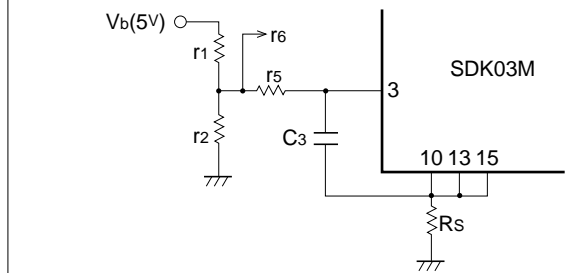

Fig. 5 Circuit for fixing the coil current

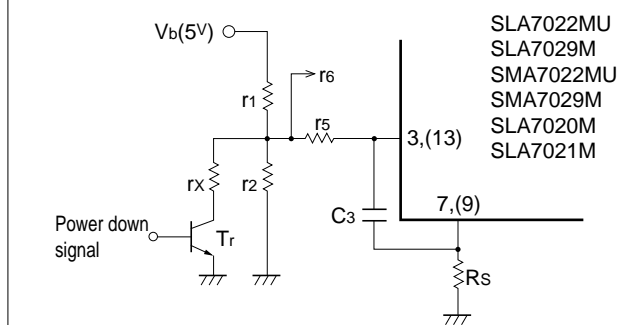

Fig. 1 Waveform of coil current (Phase A excitation ON)

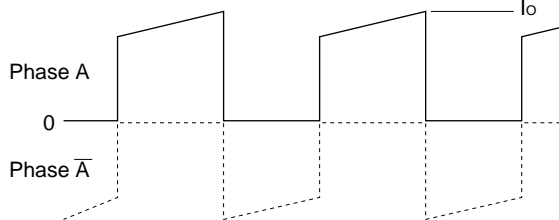
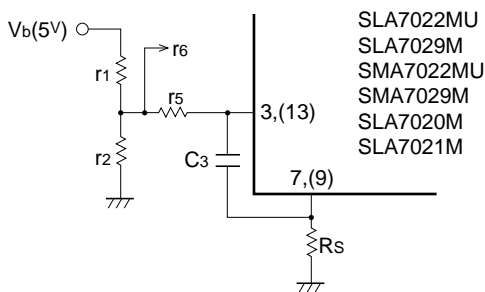

Fig. 2 Circuit for fixing the coil current



SLA7024M, SLA7026M, SLA7027MU, SLA7022MU, SLA7029M, SMA7022MU, SMA7029M, SLA7020M, SLA7021M and SDK03M

Application Note

Fig. 6 Circuit for fixing the coil current

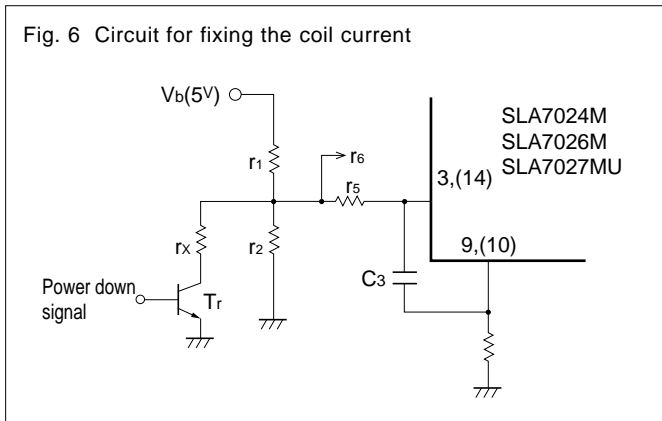

Fig. 7 Circuit for fixing the coil current

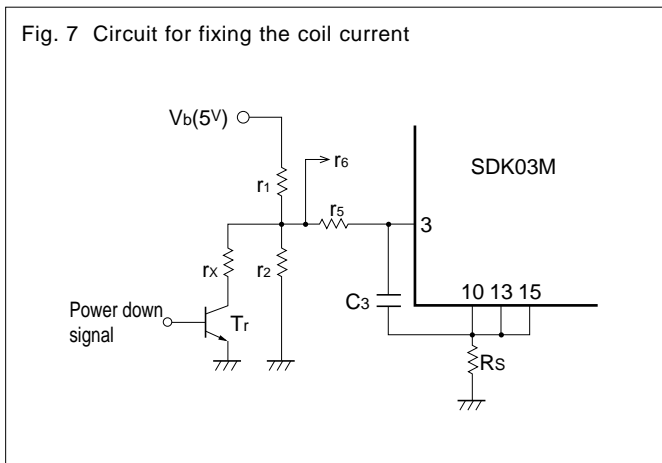

Fig. 8 and 9 show the graphs of equations ① and ②, respectively.

Fig. 8 Output current I_o vs. Current detection resistor R_s

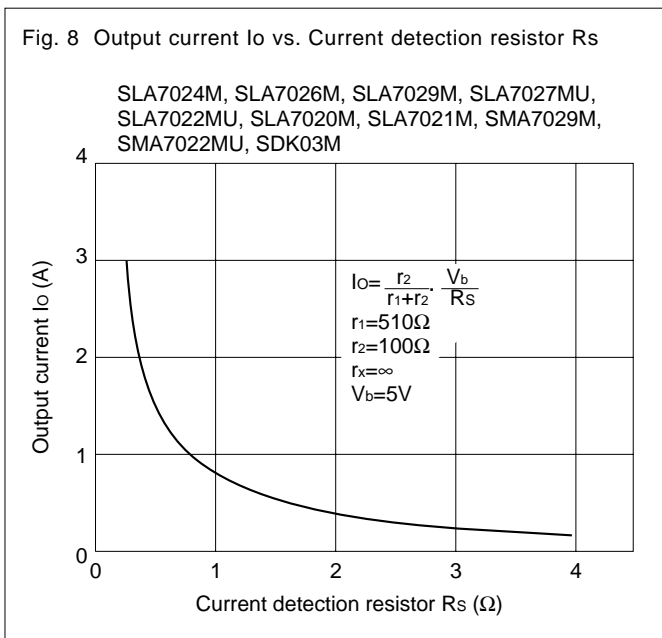
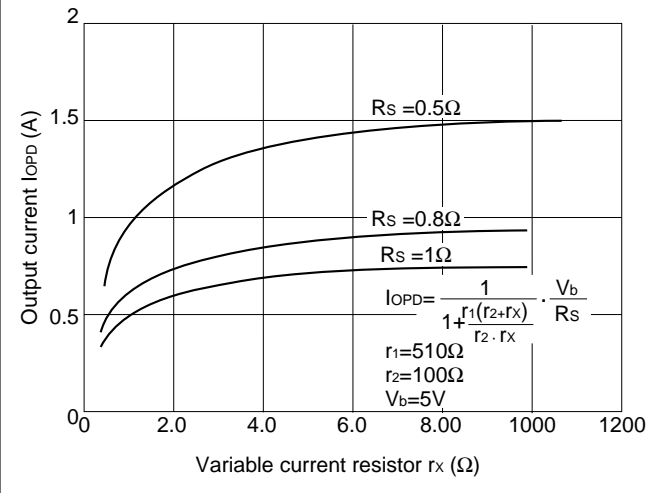

Fig. 9 Output current I_{OPD} vs. Variable current resistor r_x

SLA7024M, SLA7026M, SLA7029M, SLA7027MU, SLA7022MU, SLA7020M, SLA7021M, SMA7029M, SMA7022MU, SDK03M



NOTE:

Ringing noise is produced in the current detection resistor R_s when the MOSFET is switched ON and OFF through chopping. This noise is also generated in feedback signals from R_s which may therefore causes the comparator to malfunction.

To prevent chopping malfunctions, $r_5(r_6)$ and $C_3(C_4)$ are added in order to act as noise filter.

However, when the values of these constants are increased, the response from R_s to the comparator becomes slow. Hence, the value of the output current I_o is higher to some extent than the computed value.

SLA7024M, SLA7026M, SLA7027MU, SLA7022MU, SLA7029M, SMA7022MU, SMA7029M, SLA7020M, SLA7021M and SDK03M

Application Note

Determining the chopper frequency

Determining T_{OFF} : SLA7000M series, SMA7000M series and SDK03M are self-excited choppers. The chopping OFF time T_{OFF} is fixed by r_3/C_1 and r_4/C_2 connected to terminal Td.

T_{OFF} can be computed through the following formula:

$$T_{OFF} \doteq -r_3 \cdot C_1 \ln \left(1 - \frac{2}{V_b}\right) = -r_4 \cdot C_2 \ln \left(1 - \frac{2}{V_b}\right)$$

The circuit constants and the T_{OFF} value shown below are recommended.

$$\begin{aligned} T_{OFF} &= 12 \mu\text{s} \\ r_3 &= 47 \text{ K}\Omega \\ C_1 &= 500 \text{ pF} \\ V_b &= 5 \text{ V} \end{aligned}$$

Fig. 10 Chopper frequency vs. Motor coil resistance

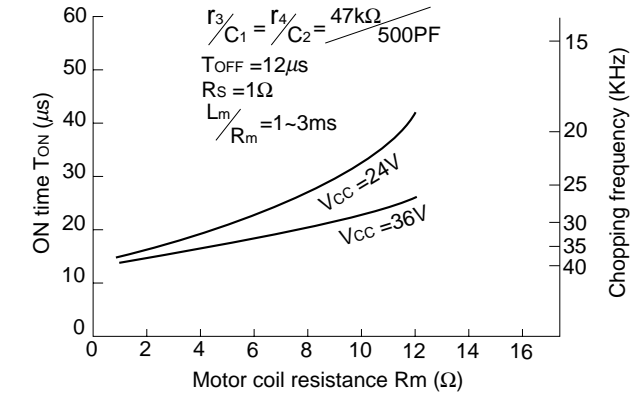

Thermal design

An outline on the method of computing heat dissipation is shown below.

- Obtain the P_H that corresponds to the motor coil current I_o from Fig. 11 "Heat dissipation per phase P_H vs. Output current I_o ".
- The power dissipation P_{diss} is obtained through the following formula.
 - SLA7000M and SMA7000M series
2-phase excitation : $P_{diss} \doteq 2P_H + 0.015 \times V_s$ (W)
1-2 phase excitation : $P_{diss} \doteq \frac{3}{2}P_H + 0.015 \times V_s$ (W)
 - SDK03M
2-phase excitation : $P_{diss} \doteq P_H + 0.015 \times V_s$ (W)
1-2 phase excitation : $P_{diss} \doteq \frac{3}{4}P_H + 0.015 \times V_s$ (W)
- Obtain the temperature rise that corresponds to the computed P_{diss} from Fig. 12 "Temperature rise curve."

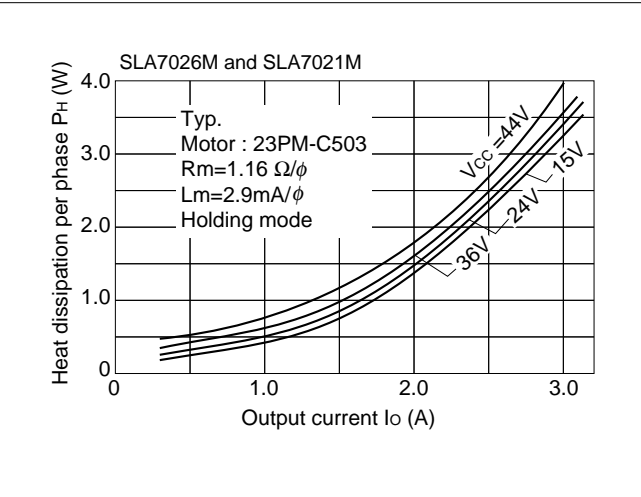
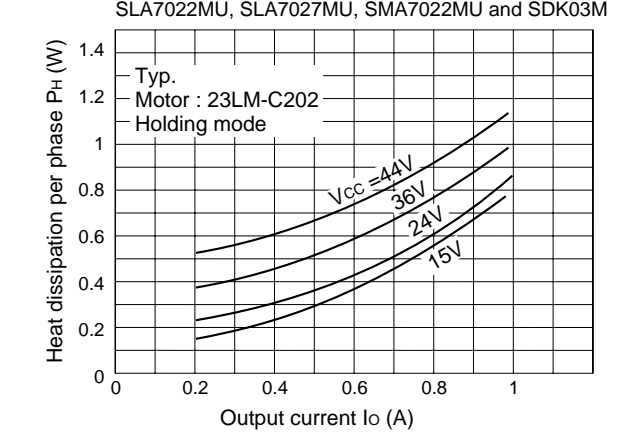
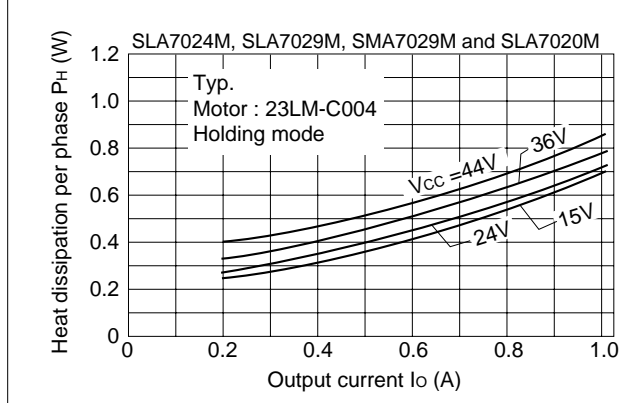

Fig. 11 Heat dissipation per phase P_H vs. Output current I_o



SLA7024M, SLA7026M, SLA7027MU, SLA7022MU, SLA7029M, SMA7022MU, SMA7029M, SLA7020M, SLA7021M and SDK03M

Application Note

Fig. 12 Temperature rise curve

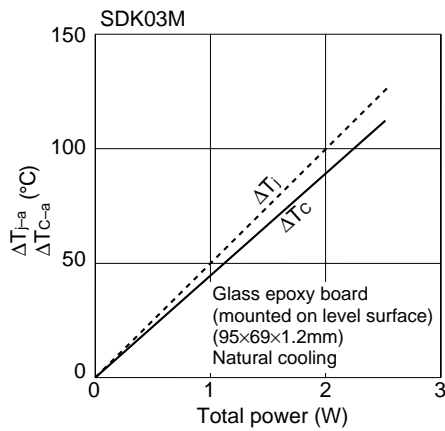
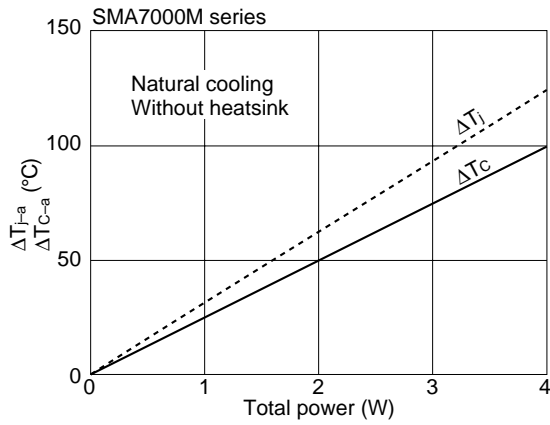
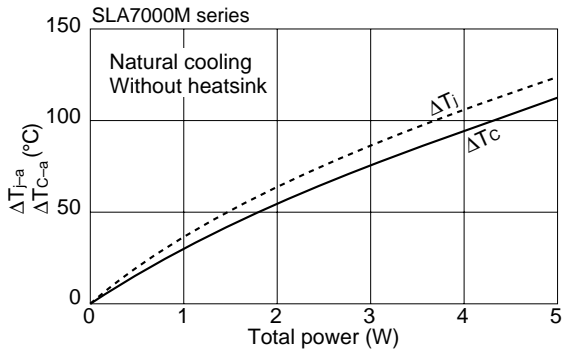

Comparison of losses

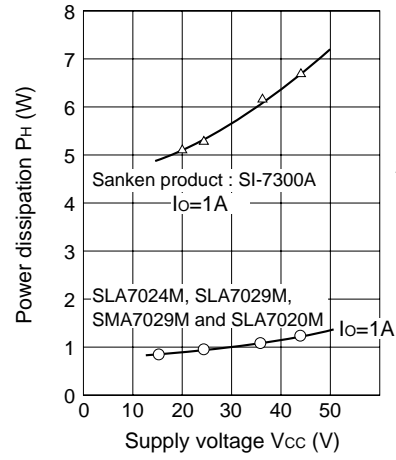

Motor : 23LM-C202
 I_o : Output current
2-phase excitation,
holding mode

SLA7024M, SLA7026M, SLA7027MU, SLA7022MU, SLA7029M, SMA7022MU, SMA7029M, SLA7020M, SLA7021M and SDK03M

Application Note

Heat dissipation characteristics

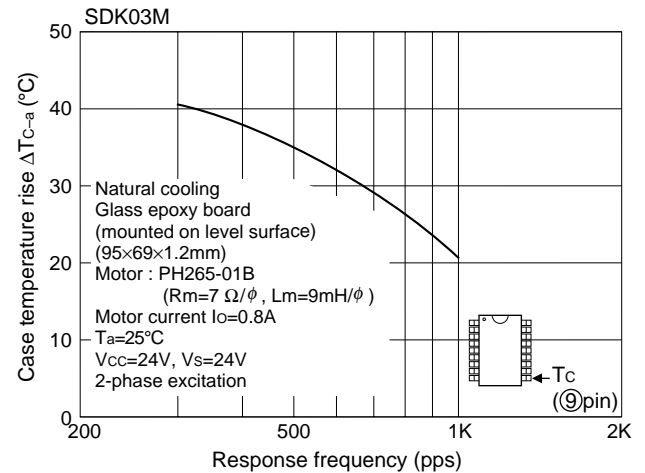
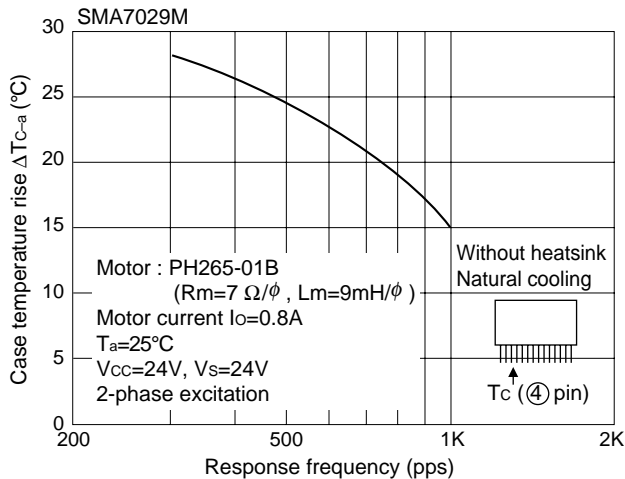
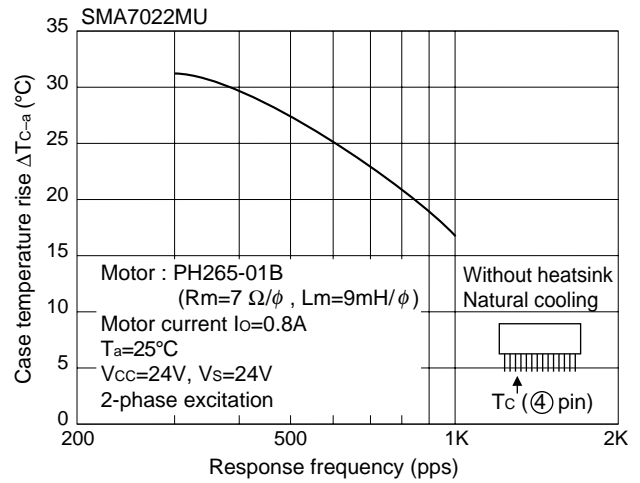
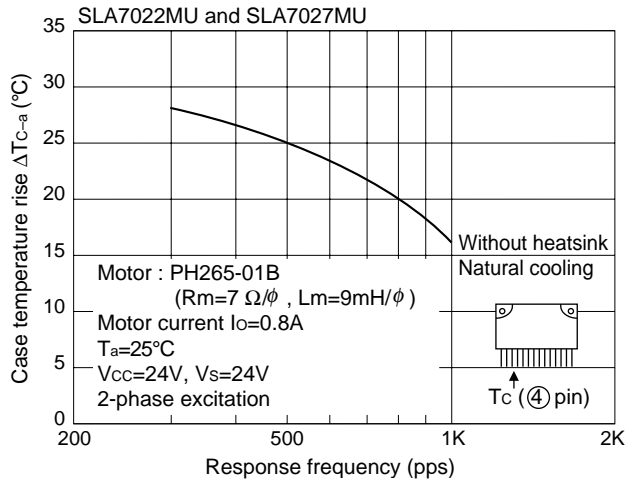
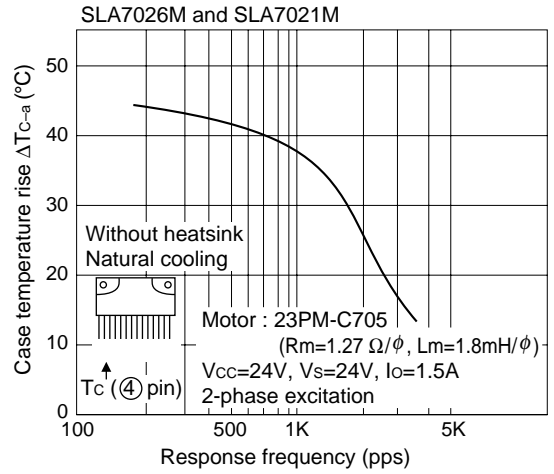
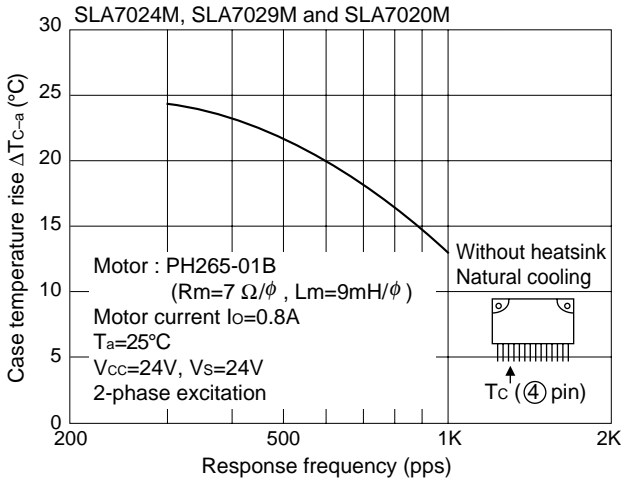

SLA7024M, SLA7026M, SLA7027MU, SLA7022MU, SLA7029M, SMA7022MU, SMA7029M, SLA7020M, SLA7021M and SDK03M

Application Note

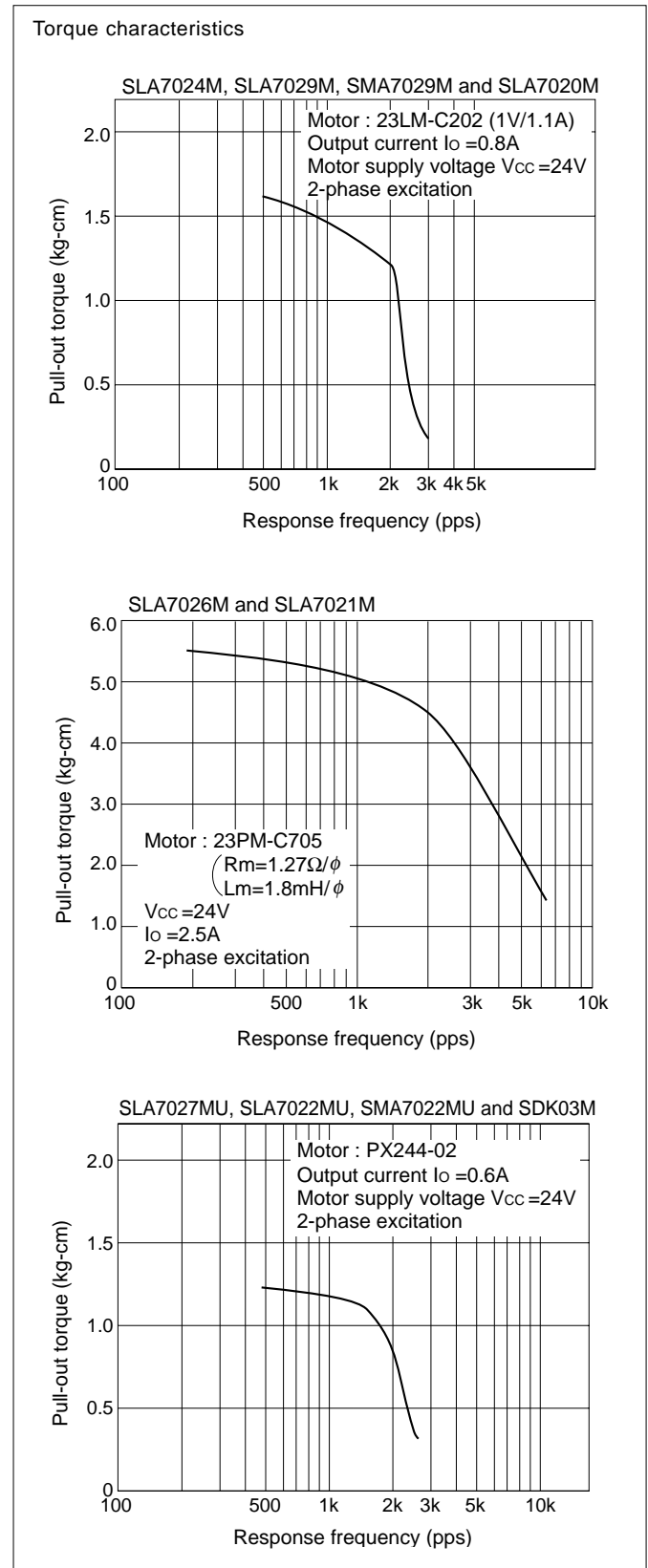
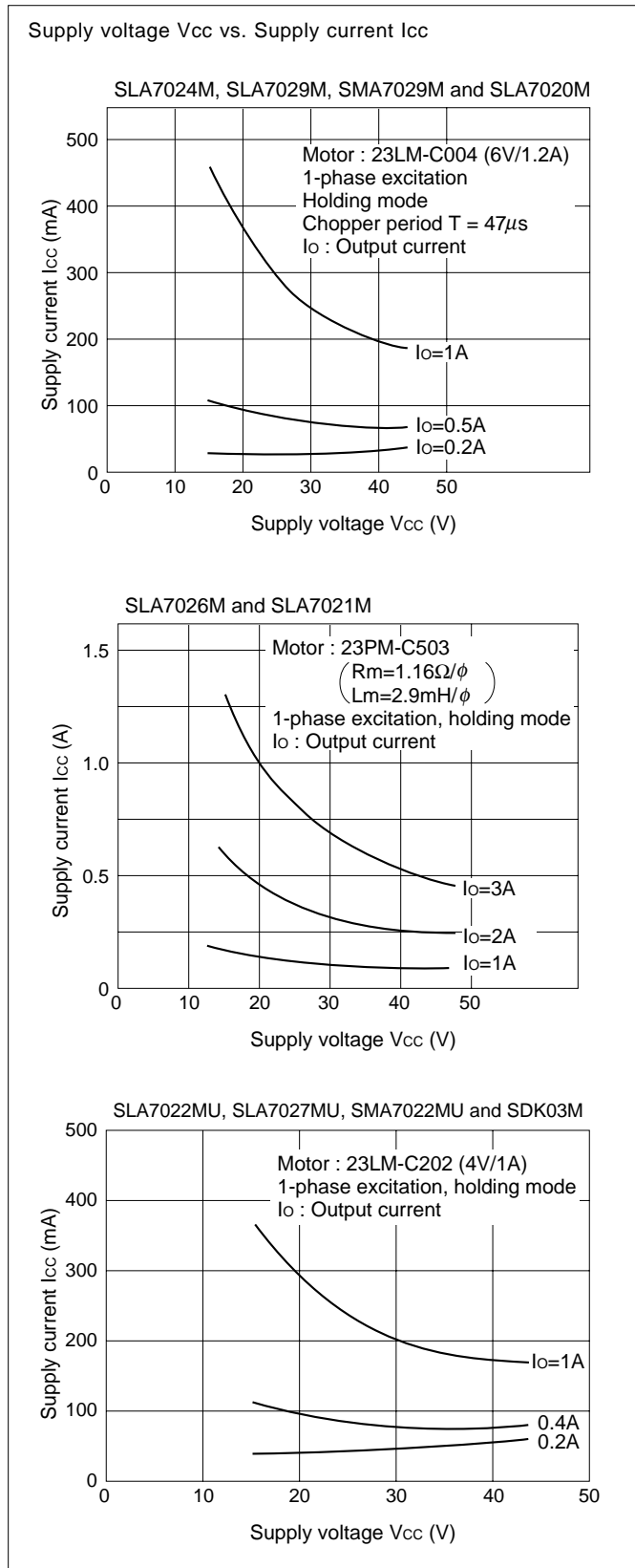

SLA7024M, SLA7026M, SLA7027MU, SLA7022MU, SLA7029M, SMA7022MU, SMA7029M, SLA7020M, SLA7021M and SDK03M

Application Note

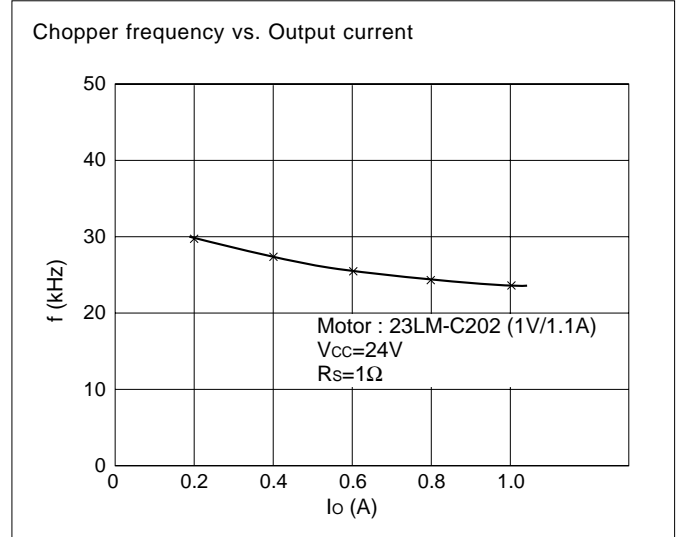
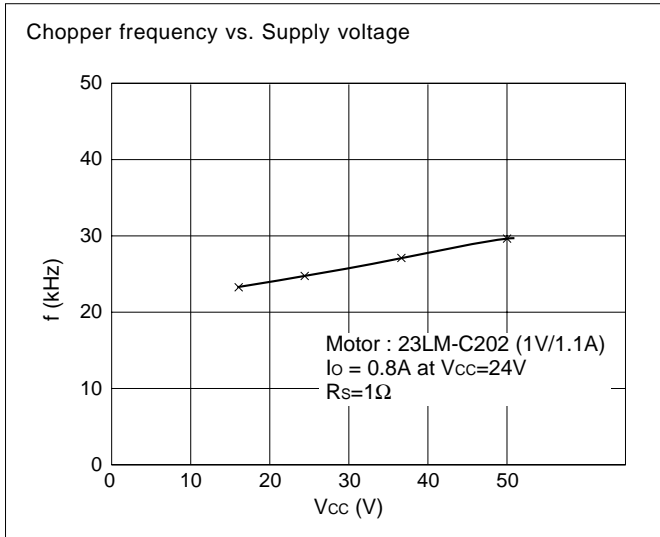

NOTE

Either active high or active low excitation input signals can be used for SLA7024M, SLA7026M, SLA7027MU and SDK03M. However, take note of the output that corresponds to a specified input as shown in the table below.

- SLA7024M, SLA7026M and SLA7027MU

Active High

| Input | Output |
|--------------------------|---------------------------|
| IN _A (6 pin) | OUT _A (1 pin) |
| IN _A (5 pin) | OUT _A (8 pin) |
| IN _B (17 pin) | OUT _B (11 pin) |
| IN _B (16 pin) | OUT _B (18 pin) |

Active Low

| Input | Output |
|--------------------------|---------------------------|
| IN _A (6 pin) | OUT _A (8 pin) |
| IN _A (5 pin) | OUT _A (1 pin) |
| IN _B (17 pin) | OUT _B (18 pin) |
| IN _B (16 pin) | OUT _B (11 pin) |

- SDK03M

Active High

| Input | Output |
|-------------------------|------------------------------|
| IN ₁ (6 pin) | OUT ₁ (1, 16 pin) |
| IN ₂ (5 pin) | OUT ₂ (8, 9 pin) |

Active Low

| Input | Output |
|-------------------------|------------------------------|
| IN ₁ (6 pin) | OUT ₁ (8, 9 pin) |
| IN ₂ (5 pin) | OUT ₂ (1, 16 pin) |