

#### FEATURES

- Pre-trimmed VCA & RMS detector
- Wide supply voltage range: 4.5V~16V
- Low supply current: 1.6 mA typ. (5V)
- Wide dynamic range: 118 dB as compander

#### APPLICATIONS

- Companding noise reduction
  - Wireless microphones
  - Wireless instrument packs
  - Wireless in-ear monitors
- Battery operated dynamics processors
  - Compressors
  - Limiters
  - AGCs
  - De-essers

#### Description

The THAT4315 is a single-chip Analog Engine® optimized for low-voltage, low-power operation. Incorporating a high-performance voltage-controlled amplifier (VCA) and RMS-level sensor, the surface mount part is aimed at battery-operated audio applications such as wireless microphones, wireless instruments and in-ear monitors. The 4315 operates from a single supply voltage down to +4.5Vdc, drawing only 1.6mA.

This IC also works at supply voltages up to 16Vdc, making it useful in line-operated products as well. The VCA is pre-trimmed at wafer stage to deliver low distortion without further adjustment.

The part was developed specifically for use as a companding noise reduction system, drawing from THAT's long history and experience with dbx® technology for noise reduction. However, with 11 active pins, the part is extremely flexible and can be configured for a wide range of applications including single and multi-band compressors, limiters, AGCs, de-essers, etc.

What really sets the 4315 apart is the transparent sound of its Blackmer™ VCA coupled with its accurate true-RMS level detector. The IC is useful in battery-powered mixers, compressor/limiters, ENG devices and other portable audio products.

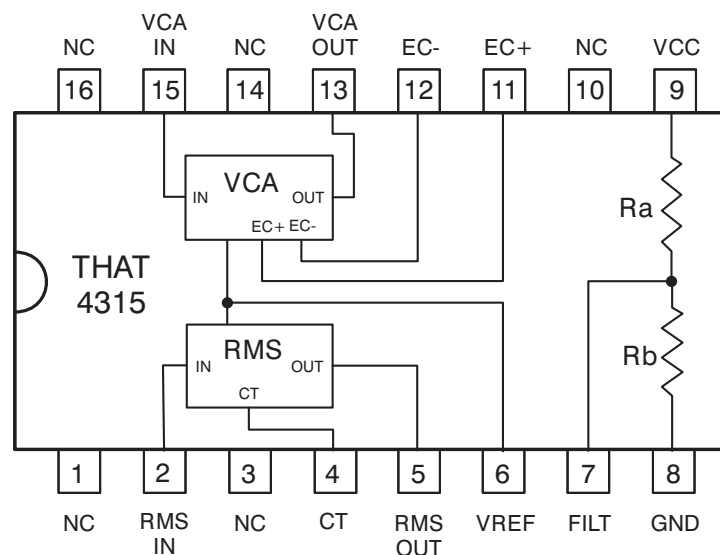

Figure 1. THAT4315 equivalent block diagram

**SPECIFICATIONS****Absolute Maximum Ratings<sup>1</sup>**

|  |                |   |                |
|--|----------------|---|----------------|
| Positive Supply Voltage ( $V_{CC}$ )     | +18V           | Power Dissipation ( $P_D$ ) at $T_A=85^\circ\text{C}$ | 400mW          |
| Supply Current ( $I_{CC}$ )              | 30mA           | Input Voltage   | Supply Voltage |
| Operating Temperature Range ( $T_{OP}$ ) | -40 to +85 °C  | Storage Temperature Range ( $T_{ST}$ )                | -40 to +125 °C |
| Junction Temperature ( $T_J$ )           | -40 to +125 °C | Lead Temperature Range (Soldering, 10 sec)            | 300 °C         |
| Output Short-Circuit Duration            | 30 sec         |   |                |

**Electrical Characteristics<sup>2</sup>**

| Parameter   | Symbol                       | Conditions  | Min  | Typ     | Max  | Units                       |
|---|------------------------------|---|------|---------|------|-----------------------------|
| <b>Power Supply</b>   |                              |   |      |         |      |                             |
| Positive Supply Voltage   | $V_{CC}$                     | Referenced to GND   | +4.5 | -       | +16  | V                           |
| Supply Current  | $I_{CC}$                     | No Signal   |      |         |      |                             |
|   |                              | $V_{CC}=+5\text{ V}$  |      | 1.6     | 2.5  | mA                          |
|   |                              | $V_{CC}=+15\text{ V}$   |      | 2.3     | 3.5  | mA                          |
| <b>Voltage Controlled Amplifier (VCA)</b>                       |                              |   |      |         |      |                             |
| Max. I/O Signal Current   | $i_{IN(VCA)} + i_{OUT(VCA)}$ | $V_{CC} = +5\text{ V}$  |      | 500     |      | $\mu\text{A}_{\text{peak}}$ |
|   |                              | $V_{CC} = +15\text{ V}$   |      | 1       |      | $\text{mA}_{\text{peak}}$   |
| VCA Gain Range  |                              |   | -50  |         | +50  | dB                          |
| Gain at 0V Control  | $G_0$                        | $E_{C+} = E_{C-} = 0\text{V}$   | -1.0 | 0       | +1.0 | dB                          |
| Gain-Control Constant   | $E_{C+}/\text{Gain (dB)}$    | -40 dB to +40 dB  | -    | 6.0     | -    | mV/dB                       |
| Gain-Control Tempco   | $\Delta E_C/\Delta T_{CHIP}$ | Ref $T_{CHIP}=27^\circ\text{C}$   | -    | +0.33   | -    | %/°C                        |
| Output Offset Voltage Change <sup>3</sup> $\Delta V_{OFF(OUT)}$ |                              | $R_{OUT} = 20\text{ k}\Omega$   |      |         |      |                             |
|   |                              | 0 dB gain   | -    | 1       | 15   | mV                          |
|   |                              | +15 dB gain   | -    | 3       | 30   | mV                          |
|   |                              | +30 dB gain   | -    | 10      | 50   | mV                          |
| Output Noise  | $e_{N(OUT)}$                 | 0 dB gain<br>22Hz~22kHz, $R_{IN}=R_{OUT}=20\text{ k}\Omega$                     | -    | -98     | -95  | dBV                         |
| Total Harmonic Distortion                                       | THD                          | $V_{IN} = -5\text{dBV}$ , 1kHz, $E_{C+} = E_{C-} = 0\text{V}$                   |      | 0.07    | 0.15 | %                           |
| <b>RMS level detector</b>                                       |                              |   |      |         |      |                             |
| Output Voltage at Reference                                     | $i_{IN} e_{O(0)}$            | $i_{IN} = 7.5\ \mu\text{A RMS}$   | -9   | 0       | +9   | mV                          |
| Output Error at Input Extremes                                  | $e_{O(RMS)error}$            | $i_{IN} = 200\text{ nA RMS}$  |      | 1       | 3    | dB                          |
|   |                              | $i_{IN} = 200\ \mu\text{A RMS}$   |      | 1       | 3    | dB                          |
| Scale Factor Match to VCA                                       |                              | -20 dB < VCA gain < +20 dB<br>$1\ \mu\text{A} < i_{IN(RMS)} < 100\ \mu\text{A}$ | .95  | 1       | 1.05 | -                           |
| Rectifier Balance   |                              | $\pm 7.5\ \mu\text{A DC}_{IN}$  |      | $\pm 1$ |      | dB                          |

1. If the devices are subjected to stress above the Absolute Maximum Ratings, permanent damage may result. Sustained operation at or near the Absolute Maximum Ratings conditions is not recommended. In particular, like all semiconductor devices, device reliability declines as operating temperature increases.

2. Unless otherwise noted,  $T_A=25^\circ\text{C}$ ,  $V_{CC}=+5\text{V}$ ,  $V_{EE}=0\text{ V}$ .

3. Reference is to output offset with -80dB VCA gain.

| <b>Electrical Characteristics (con't)<sup>2</sup></b>             |                                       |   |          |                               |          |                     |
|---|---------------------------------------|---|----------|-------------------------------|----------|---------------------|
| Parameter   | Symbol                                | Conditions  | Min      | Typ                           | Max      | Units               |
| Timing Current  | $I_T$                                 |   | -        | 7.5                           | -        | $\mu\text{A}$       |
| Filtering Time Constant   | $\tau$                                | $T_{\text{CHIP}} = 27\text{ }^\circ\text{C}$  |          | $3467 \times C_{\text{TIME}}$ |          | s                   |
| Output Tempco   | $\Delta E_O / \Delta T_{\text{CHIP}}$ | Ref $T_{\text{CHIP}} = 27\text{ }^\circ\text{C}$  | -        | +0.33                         | -        | %/ $^\circ\text{C}$ |
| Load Resistance   | $R_L$                                 | $-250\text{mV} < V_{\text{OUTRMS}} < +250\text{mV}$ , re:Vref                                   | 2        |                               |          | $\text{k}\Omega$    |
| Capacitive Load   | $C_L$                                 |   |          |                               | 150      | pf                  |
| <b>Vcc/2 Reference Divider</b>                                    |                                       |   |          |                               |          |                     |
| Reference Voltage   | $V_{\text{REF}}$                      | No Signal, No load on pin 7,<br>$V_{\text{CC}} = +5\text{ V}$<br>$V_{\text{CC}} = +15\text{ V}$ | 2.4<br>- | 2.5<br>$V_{\text{CC}}/2$      | 2.6<br>- | V<br>V              |
| Voltage Divider Impedance   | $R_A, R_B$                            |   | -        | 20                            | -        | $\text{k}\Omega$    |
| <b>Performance as a Comander (through an encode-decode cycle)</b> |                                       |   |          |                               |          |                     |
| Dynamic Range   |                                       | (Max signal level) - (No Signal Output Noise)   |          | 120                           |          | dB                  |
| Distortion  | THD                                   | $f = 1\text{ kHz}$  |          | 0.15                          |          | %                   |
| Frequency response  | -20 dB re: Max Signal                 | 20 Hz ~ 20 kHz  |          | $\pm 1.5$                     |          | dB                  |

| <b>Package Characteristics</b> |                      |                                       |     |   |     |                           |
|--------------------------------|----------------------|---------------------------------------|-----|---|-----|---------------------------|
| Parameter                      | Symbol               | Conditions                            | Min | Typ   | Max | Units                     |
| <b>Surface Mount Package</b>   |                      |                                       |     |   |     |                           |
| Type                           |                      | See page 12 for pinout and dimensions |     | 16 Pin QSOP                                 |     |                           |
| Thermal Resistance             | $\theta_{\text{JC}}$ | SO package in ambient                 |     | TBD   |     | $^\circ\text{C}/\text{W}$ |
| Thermal Resistance             | $\theta_{\text{JA}}$ | SO package soldered to board          |     | TBD   |     | $^\circ\text{C}/\text{W}$ |
| Soldering Reflow Profile       |                      |                                       |     | JEDEC JESD22-A113-D (250 $^\circ\text{C}$ ) |     |                           |

## **Theory of Operation**

The THAT 4315 Dynamics Processor combines THAT Corporation's proven Voltage-Controlled Amplifier (VCA) and an RMS-Level Detector in a package optimized for low cost circuits. The part is integrated using a proprietary, fully complementary, dielectric-isolation process. This process produces very high-quality bipolar transistors (both NPNs and PNPs) with unusually low collector-substrate capacitances. The 4315 takes advantage of these devices to deliver wide bandwidth and excellent audio performance while consuming very low current and operating over a wide range of power supply voltages.

For details of the theory of operation of the VCA and RMS Detector building blocks, the interested

reader is referred to THAT Corporation's data sheets on the 2180-Series VCAs and the 2252 RMS Level Detector. Theory of the interconnection of exponentially-controlled VCAs and log-responding level detectors is covered in THAT Corporation's application note AN101A, *The Mathematics of Log-Based Dynamic Processors*.

### **The VCA — in Brief**

The VCA in THAT 4315 is based on THAT Corporation's highly successful complementary log-antilog gain cell topology — The Blackmer VCA™ — as used in THAT 2180-Series IC VCAs. VCA symmetry is trimmed during wafer probe for minimum distortion. No external adjustment is allowed.

Input signals are currents in the VCA's IN pin. This pin is a virtual ground with dc level approximately equal to  $V_{REF}$ , so in normal operation an input voltage is converted to input current via an appropriately sized resistor. Because the currents associated with dc offsets present at the input pin and any dc offset in preceding stages will be modulated by gain changes (thereby becoming audible as thumps), the input pin is normally ac-coupled.

The VCA output signal is also a current, inverted with respect to the input current. In normal operation, the output current is converted to a voltage via external op-amp, where the ratio of the conversion is determined by the feedback resistor connected between op-amp's output and its inverting input. The signal path through the VCA and op-amp is noninverting.

The gain of the VCA is controlled by the voltage applied between EC+ and EC-. Note that any unused control port should be connected to the Vref generator. The gain (in decibels) is proportional to (EC+ - EC-). The constant of proportionality is 6.0 mV/dB for the voltage at EC+ (relative to EC-), but note that neither EC+ or EC- should vary more than  $\pm 0.5$  V from  $V_{REF}$ .

The VCA's noise performance varies with gain in a predictable way, but due to the way internal bias currents vary with gain, noise at the output is not strictly the product of a static input noise times the voltage gain commanded. At large attenuation, the noise floor of  $\sim -109$  dBV is limited by the input noise of the output op-amp and its feedback resistor. At 0 dB gain, the noise floor is  $\sim -98$  dBV as specified. In the vicinity of 0 dB gain, the noise increases more slowly than the gain: approximately 5 dB noise increase for every 10 dB gain increase. Finally, as gain approaches 30 dB, output noise begins to increase directly with gain.

While the 4315's VCA circuitry is very similar to that of the THAT 2180 Series VCAs, there are several important differences, as follows:

1. Supply current for the VCA depends on  $V_{CC}$ . At +5 V  $V_{CC}$ , approximately 500  $\mu$ A is available for the sum of input and output signal currents. This increases to about 1 mA at +15 V  $V_{CC}$ . (Compare this to  $\sim 1.8$  mA for a 2180 Series VCA when biased as recommended. This is appropriate given the lower supply voltage for the 4315.)

2. A SYM control port (similar to that on the 2180 VCA) exists, but is driven from an internally trimmed current generator.

3. The control-voltage constant is approximately 6.0 mV/dB, due primarily to the lower internal operating temperature of the 4315 compared to that of the 2180 Series (and the 4301).

4. The OTA used for the VCA's internal opamp in the 4315 uses less emitter degeneration resistance in its output than that of the 2180 VCA. This requires that the source impedance at the VCA's input (which is a summing junction) must be under 5 k $\Omega$  at frequencies over 1 MHz. See the applications section for an alternative on how to address this issue.

## The RMS Detector — in Brief

The 4315's detector computes RMS level by rectifying input current signals, converting the rectified current to a logarithmic voltage, and applying that voltage to a log-domain filter. The output signal is a dc voltage proportional to the decibel-level of the RMS value of the input signal current. Some ac component (at twice the input frequency) remains superimposed on the dc output. The ac signal is attenuated by a log-domain filter, which constitutes a single-pole rolloff with cutoff determined by an external capacitor.

As in the VCA, input signals are currents to the RMS<sub>IN</sub> pin. This input is a virtual ground with dc level equal to  $V_{REF}$ , so a resistor, R24 in Figure 2, is normally used to convert input voltages to the desired current. The level detector is capable of accurately resolving signals well below 10 mV (with a 5 k $\Omega$  input resistor). However, if the detector is to accurately track such low-level signals, ac coupling is required. Note also that small, low-voltage electrolytic capacitors used for this purpose may create significant leakage if they support half the supply voltage, as is the case when the source is dc-referenced to ground. To ensure good detector tracking to low levels, a high quality electrolytic may be required for input coupling.

The log-domain filter cutoff frequency is usually placed well below the frequency range of interest. For an audio-band detector, a typical value would be 5 Hz, or a 32 ms time constant ( $\tau$ ). The filter's time constant is determined by an external timing capacitor attached to the CT pin, and an internal current source ( $I_T$ ) connected to CT. The current source is internally fixed at 7.5  $\mu$ A. The resulting time constant in seconds is approximately equal to 3467 times the value of the timing capacitor. Note that, as a result of the mathematics of RMS detection, the attack and release time constants are fixed in their relationship to each other.

The RMS detector is capable of driving large spikes of current into  $C_{TIME}$ , particularly when the audio signal input to the RMS detector increases suddenly. This current is drawn from  $V_{CC}$  (pin 9), fed through  $C_{TIME}$  at pin 4, and returns to the power supply through the ground end of  $C_{TIME}$ . If not handled properly through layout and bypassing, these currents can mix with the audio with unpredictable and undesirable results. As noted in the Applications section, local bypassing from the  $V_{CC}$  pin to the ground end of  $C_{TIME}$  is strongly recommended in order to keep these currents out of the ground structure of the device.

The dc output of the detector is scaled with the same constant of proportionality as the VCA gain control: 6.0 mV/dB. The detector's 0 dB reference ( $i_{in0}$ , the input current which causes the detector's output to equal  $V_{REF}$ ), is trimmed during wafer probe to approximately equal 7.5  $\mu$ A. The RMS detector output stage is capable of sinking or sourcing 125  $\mu$ A. It is also capable of driving up to 150 pF of capacitance.

Frequency response of the detector extends across the audio band for a wide range of input signal levels. Note, however, that it does fall off at high frequencies at low signal levels.

Differences between the 4315's RMS Level Detector circuitry and that of the THAT 2252 RMS Detector include the following.

1. The rectifier in the 4315 RMS Detector is internally balanced by design, and cannot be balanced via an external control. The 4315 will typically balance positive and negative halves of the input signal within 10 %, but in extreme cases the mismatch may reach +40, -30 % ( $\pm 3$  dB). However, even such extreme-sounding mismatches will not significantly increase ripple-induced distortion in dynamics processors over that caused by signal ripple alone.

2. The time constant of the 4315's RMS detector is determined by the combination of an external capacitor (connected to the  $C_T$  pin) and an internal current source. The internal current source is set to about 7.5  $\mu$ A. A resistor is not normally connected directly to the  $C_T$  pin on the 4315.

3. The 0 dB reference point, or level match, is also set to approximately 7.5  $\mu$ A. However, as in the 2252, the level match will be affected by any additional currents drawn from the  $C_T$  pin.

## $V_{CC}/2$ Reference Buffer

For single-supply applications, the 4315 requires a center-tap to provide a synthetic "ground" reference for its circuitry. The 4315 contains a built-in resistive divider (at pins 7, 8 and 9), but unlike the THAT4320, this voltage is unbuffered. Note that the center tap of the resistive divider is brought out to filter the voltage, thereby minimizing noise in the divider. A large electrolytic capacitor (typically 22  $\mu$ F or greater) is used for this purpose. In cases where users expect to dump significant current onto  $V_{REF}$ , the user should add an op-amp to provide a low-impedance source at approximately half  $V_{CC}$ .

Connecting the positive control port,  $E_{c+}$ , directly to the unbuffered  $V_{CC}/2$  reference can result in shifts of up to  $\pm 900$  mV in the reference voltage due to DC currents flowing in or out of this pin as a result of the internal VCA symmetry trim. In such cases, buffering of the  $V_{CC}/2$  reference voltage is recommended. As an alternative, a lower impedance external voltage divider can be substituted (2 k $\Omega$  resistors will limit any variation in  $V_{CC}/2$  to less than 100 mV).

Any signal currents should return to the real circuit ground (GND);  $V_{REF}$  should be connected only to relatively high impedance loads (e.g., the positive input of opamps). Where significant currents (signal or otherwise) must be delivered at the  $V_{REF}$  dc level, an opamp should be used to buffer the  $V_{REF}$  line itself.

Another approach to power supply arrangements is to operate the 4315 from symmetrical split supplies (e.g.  $\pm 5$  V and ground). In such cases, the center-tap of the resistive divider (pin 7) should be grounded. This will force  $V_{REF}$  to ground within the offset of the  $V_{CC}/2$  buffer.

## Noise Reduction (Compander) Configurations

A primary use of the 4315 is for noise reduction systems, particularly within battery-operated devices. In these applications, one 4315 is configured for use as a compressor to condition audio signals before feeding them into a noisy channel. A second 4315, configured as an expander, is located at the receiver end of the noisy channel. The compressor increases gain in the presence of low-level audio signals, and reduces its gain in the presence of high-level audio signals. The expander works in opposite, complementary fashion to restore the origi-

nal signal levels present at the input of the compressor.

During low-level audio passages, the compressor increases signal levels, bringing them up above the noise floor of the noisy channel. At the receiving end, the expander reduces the signal back to its original level, in the process attenuating the channel noise.

During high-level audio passages, the compressor decreases signal levels, reducing them to fit within the headroom limits of the noisy channel. The expander increases the signal back to its original level. While the channel noise may be increased by this action, in a well-designed compander, the noise floor will be masked by the high-level signal.

The 4315 was designed to facilitate the design of

a wide variety of companding noise reduction systems. The RMS detector responds accurately over a wide range of levels; the VCA responds accurately to a wide range of gain commands; the detector output and the VCA control input are fully configurable. All these features mean that the 4315 will support a wide range of compander designs (and more), including simple 2:1 wide range (level-independent) systems, level-dependent systems with thresholds and varying compression slopes, systems including noise gating and/or limiting, and systems with varying degrees of pre-emphasis and filtering in both the signal and detector paths. Furthermore, much of this can be accomplished by extensively conditioning the control voltage sidechain rather than the audio signal itself. The audio signal can pass through as little as one VCA and one opamp, and still support multiple ratios, thresholds, and time constants.

## Applications

The 4315 provides the basic building blocks suitable for a wide variety of dynamics processing applications. Chief among these are wireless companding systems. For this datasheet, we show the part in a simple 2:1 companding noise reduction system that performs as well or better than any analog companding solution on the market today. Many other configurations of the 4315 are possible, but are not shown here. THAT intends to publish additional circuits in forthcoming applications notes. Please check with THAT's applications engineering department to see if your application has been covered yet, and for personalized assistance with specific designs.

### The mathematics of log based companding systems

Using the principles described in AN101A, [The Mathematics of Log Based Dynamics Processors](#), we can state that for Figure 2,

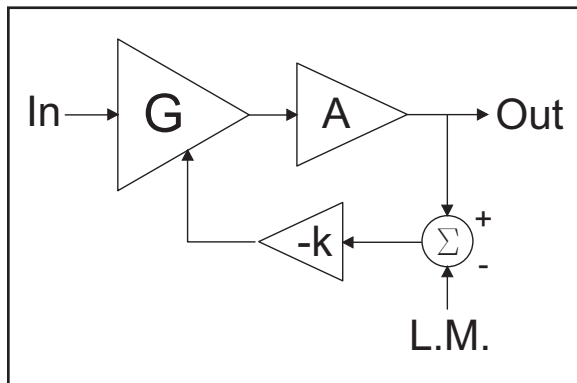

Figure 2. Feedback compressor.

$$Out = In + G + A$$

Where  $G$  is the VCA's control port gain in dB, and  $A$  is any static gain or attenuation (in dB) applied to the signal. We can also state that:

$$G = k(L.M. - Out)$$

Where  $L.M.$  is the zero dB reference point (often referred to as level match point) of the detector, and  $k$  is the gain of the sidechain. Substituting the second equation into the first,

$$Out = In + k(L.M. - Out) + A, \text{ Or}$$

$$Out = In + k \cdot L.M. - k \cdot Out + A, \text{ Or}$$

$$Out = \frac{In + k \cdot L.M. + A}{(1+k)}$$

For the decoder shown in Figure 3, we can state that:

$$Out = In + A + G, \text{ And that:}$$

$$G = k(In - L.M.), \text{ Thus:}$$

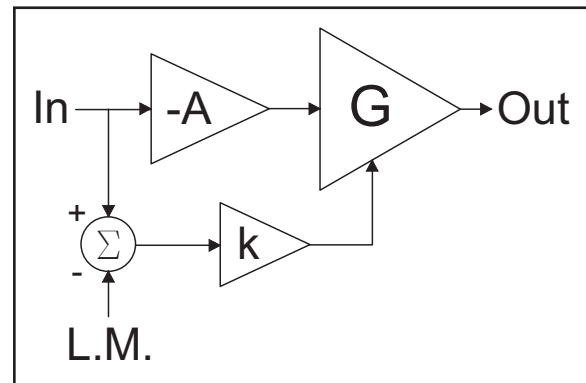

Figure 3. Feedforward expander.



$$Out = In(1 + k) + (-A) - k \cdot L.M.$$

Note that for the decoder, A will have the opposite polarity of A in the Encoder

Using these methods, it can also be shown that both the compression ratio (C.R.) of a feedback compressor and the expansion ratio for a feedforward expander is

$$E.R. = C.R. = 1 + k$$

where k is the absolute value of the gain of the side chain.

### The encoder

Figure 4 shows a simple 2:1 encoder or feedback compressor. The encoder in a wireless companding system is located in the transmitter and generally operates from a battery supply. The static gain of this circuit is 1, or zero dB, and a 5 kΩ resistor along with a 220 pF capacitor comprise the compensation network is required to keep the VCA's input amplifier stable for all gains. Since the RMS detector output is tied directly to the VCA's EC-, the compression ratio will be 2:1. Note that the use of the negative-sense control port, EC-, makes this circuit a compressor. The RMS detector timing capacitor is set for a release rate of -125 dB per second by using a value of 10 uF.

As described in the Theory of Operation section "The RMS Detector - In Brief", the RMS detector is capable of driving large spikes of current into the averaging capacitor C<sub>TIME</sub>. To prevent these currents from upsetting circuit grounds, it is necessary to bypass VCC to a point very near the grounded end of the C<sub>TIME</sub> with a capacitor equal to or greater than the value of C<sub>TIME</sub>. The grounded ends of these two capacitors should be connected together before being tied to the rest of the ground system. Doing so will ensure that the current spikes flow within the local loop consisting of the two capacitors, and stay out of the ground system. This requirement applies to the decoder and other applications of the THAT4315 as well.

The output of the RMS detector is zero volts when the RMS input current is equal to the timing current (internally set to ~7.5 mA). A low-frequency voltage level of -28.5 dBV was chosen as the desired zero dB reference. The RMS detector's input resistance can be calculated as:

$$R_{RMS\ in} = \frac{10^{-\frac{28.5}{20}}}{7.5\mu A} \cong 5k\Omega$$

This value also applies to the decoder.

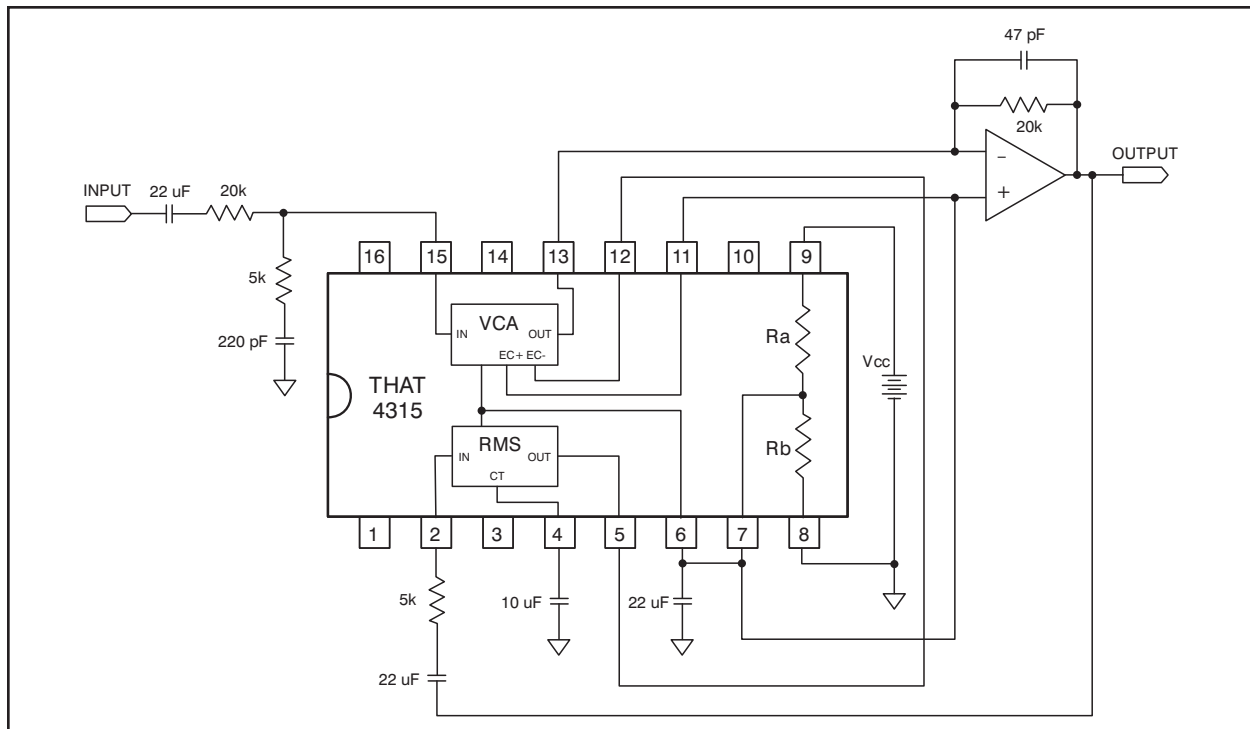

Figure 4. 4315 Typical Application Circuit - 2:1 Compressor

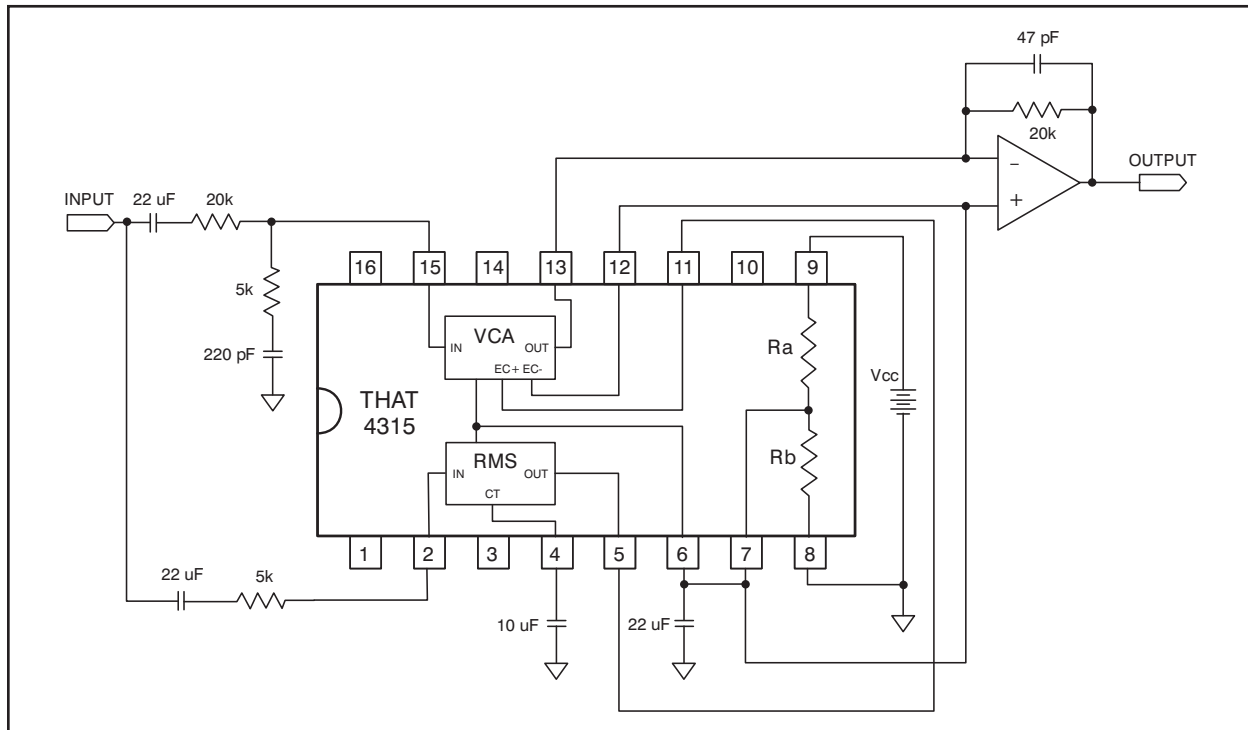

Figure 5. 4315 Typical Application Circuit - 1:2 Expander

## The decoder

Figure 5 shows the THAT4315 configured as a 2:1 expander, an arrangement intended to complement the encoder in Figure 4. This circuit is optimized for low-voltage operation, as might be the case for a decoder in an in-ear monitoring system which will run from battery power.

This circuit also uses a static gain of zero dB. Since the VCA is not stable unless it sees a high frequency source impedance of 5 kΩ or less, another compensation network is provided to maintain stability.

In this instance, the RMS detector output is connected to EC+; This reverses the polarity of the control signal relative to the encoder, and makes this circuit a 2:1 expander.

## System Performance

Table 1 shows the transfer characteristics of this companding system. The Columns labeled Encoder VCA Gain, Encoder Out, Decoder VCA Gain, and Decoder Out use the equations derived previously in the section titled “The Mathematics of Log Based Companding Systems”. The values in the column labeled RMS In are derived using the equation:

$$I_{RMS In} = \frac{10^{\frac{Encoder Out}{20}}}{R_{RMS In}}$$

One can see that the required gain range is  $\pm 41$  dB, which is easily within the capabilities of the 4315 VCA. The range of RMS input currents is easily accommodated at the high end, but accuracy may be slightly compromised at the lowest input levels, below -100 dBV.

## Hi-fi Compander

While the previous circuits perform adequately in some applications, a few minor changes can result in substantially improved overall performance. The following compander implementation adds

| Encoder In | Encode VCA Gain | Encoder Out/ Decoder In | $I_{RMS In}$ | Decoder VCA Gain | Decoder Out |
|------------|-----------------|-------------------------|--------------|------------------|-------------|
| (dBV)      | (ln dB)         | (dBV)                   | (mA)         | (ln dB)          | (dBV)       |
| -0         | -14             | -14                     | 0.0773       | 14               | -0          |
| -10        | -9              | -19                     | 0.0435       | 9                | -10         |
| -20        | -4              | -24                     | 0.0244       | 4                | -20         |
| -30        | 1               | -29                     | 0.0137       | -1               | -30         |
| -40        | 6               | -34                     | 0.0077       | -6               | -40         |
| -50        | 11              | -39                     | 0.0043       | -11              | -50         |
| -60        | 16              | -44                     | 0.0024       | -16              | -60         |
| -70        | 21              | -49                     | 0.0014       | -21              | -70         |
| -80        | 26              | -54                     | 0.0008       | -26              | -80         |
| -90        | 31              | -59                     | 0.0004       | -31              | -90         |
| -100       | 36              | -64                     | 0.0002       | -36              | -100        |
| -110       | 41              | -69                     | 0.0001       | -41              | -110        |

Table 1. 2:1 compander transfer characteristics



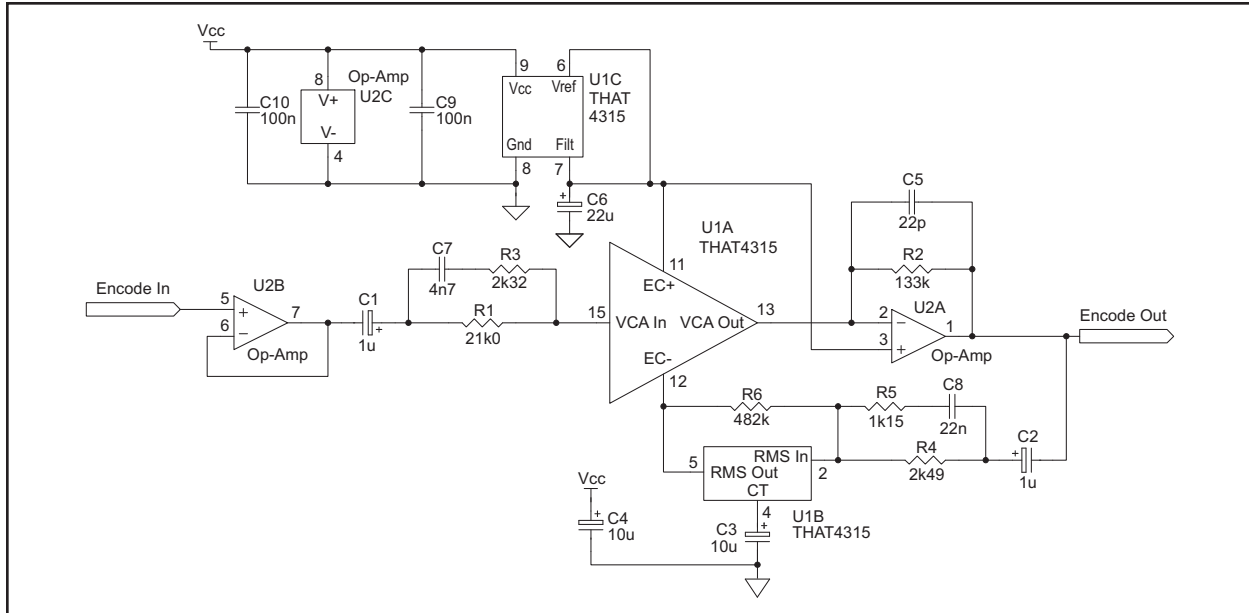

Figure 6. HiFi 2:1 encoder circuit

pre/de-emphasis to the signal path. Pre-emphasis helps overcome the “aqua” characteristics of the FM RF channel by raising the level of the higher frequency portion of the signal while it is in the transmission channel. The de-emphasis in the decoder brings the frequency response of the signal back to flat while simultaneously lowering the noise floor of the channel.

RMS pre-emphasis is added to both detectors. This helps the system respond to impulse signals that are accentuated by the signal pre-emphasis, and result in a superior swept sine response.

Additionally, a means to “floor out” the RMS detector is demonstrated. This helps improve low level tracking in situations where one detector performs substantially better than specified.

### Encoder

The encoder shown in Figure 6 implements all of the aforementioned improvements. In the signal path, there is a static gain at low frequencies of 16 dB;

$$A_V = \frac{133k\Omega}{21k\Omega} \approx 6.3$$

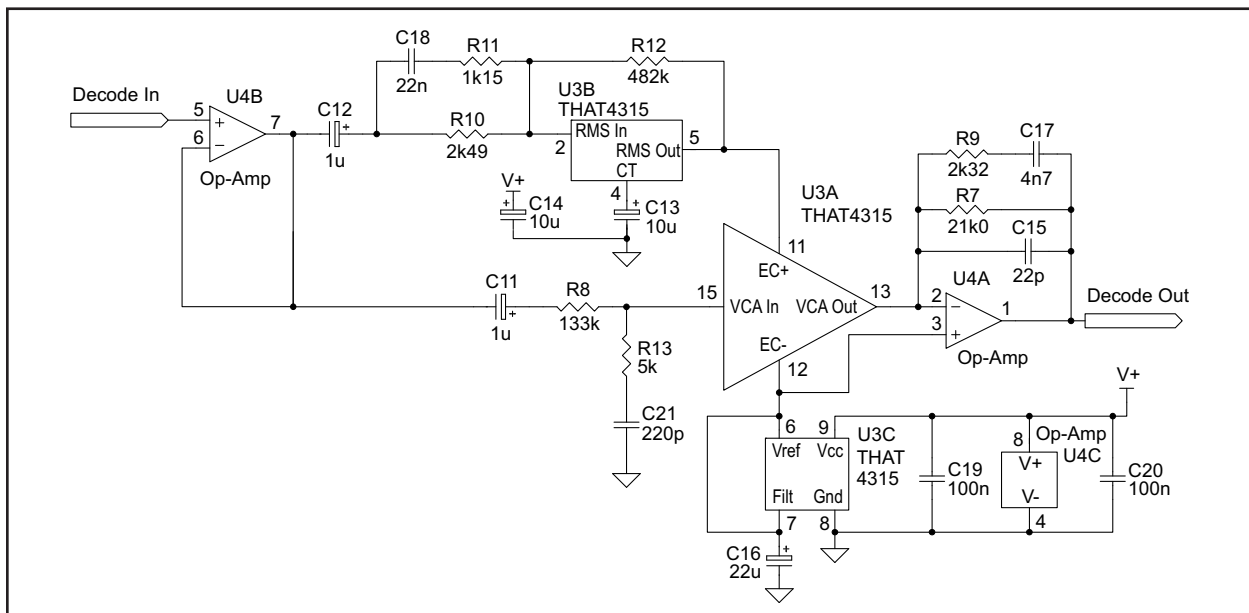

Figure 7. HiFi 2:1 Decoder circuit

| Encoder In | Encoder VCA Gain | Encoder Out/ Decoder In | $I_{RMS}$ In | Decoder VCA Gain | Decoder Out |
|------------|------------------|-------------------------|--------------|------------------|-------------|
| (dBV)      | (ln dB)          | (dBV)                   | (mA)         | (ln dB)          | (dBV)       |
| -0         | -25              | -9                      | 0.1375       | 25               | -0          |
| -10        | -20              | -14                     | 0.0773       | 20               | -10         |
| -20        | -15              | -19                     | 0.0435       | 15               | -20         |
| -30        | -10              | -24                     | 0.0244       | 10               | -30         |
| -40        | -5               | -29                     | 0.0137       | 5                | -40         |
| -50        | 0                | -34                     | 0.0077       | 0                | -50         |
| -60        | 5                | -39                     | 0.0043       | -5               | -60         |
| -70        | 10               | -44                     | 0.0024       | -10              | -70         |
| -80        | 15               | -49                     | 0.0014       | -15              | -80         |
| -90        | 20               | -54                     | 0.0008       | -20              | -90         |
| -100       | 25               | -59                     | 0.0004       | -25              | -100        |
| -110       | 30               | -64                     | 0.0002       | -30              | -110        |

Table 2. Hi-fi comander transfer characteristics

At 20 kHz, the gain is;

$$A = \frac{133k\Omega}{21k\Omega \parallel 232k\Omega} \cong 63.7$$

Or 36 dB, which means there is nominally 20 dB of signal pre-emphasis at 20 kHz. Note additionally that this added pre-emphasis also compensates the input to the VCA, so additional components are not required to implement this feature. The input to this network is buffered by U2B, and while this is not strictly necessary, the network must be driven from a low source impedance to ensure proper tracking between the encoder pre-emphasis and the

decoder de-emphasis. If this network is driven from an unbuffered source, then the network should be adjusted to take into account the impedance of that source.

There is 10 dB of RMS pre-emphasis for the detectors in both the encoder and the decoder. The center frequency of this pre-emphasis circuit is aligned with the center frequency of the signal path pre-emphasis when evaluated on a logarithmic frequency scale.

R6 in the encoder and R12 in the decoder are used to “floor out” the detectors at low levels. There are a few reasons why a designer might choose to do this. There is some variability in the low-level performance of these detectors, and some will occasionally perform substantially better than typical, and this can result in mis-tracking at low levels. A more common problem is that there is some additional filtering seen by the decoder RMS detector; This is usually is caused by band limiting in the RF detector’s signal path. As a result, 2 detectors in the system see a different noise floor, and this can result in mis-tracking.

The values of R6 and R12 were chose to cause the detector to stop responding to input signals that are 27 dB below level match. The value is determined by

$$R_{floor} = \frac{(27\text{ dB} \cdot \frac{6\text{mV}}{\text{dB}})}{7.5\mu\text{A} \cdot 10^{\frac{-27}{20}}}$$

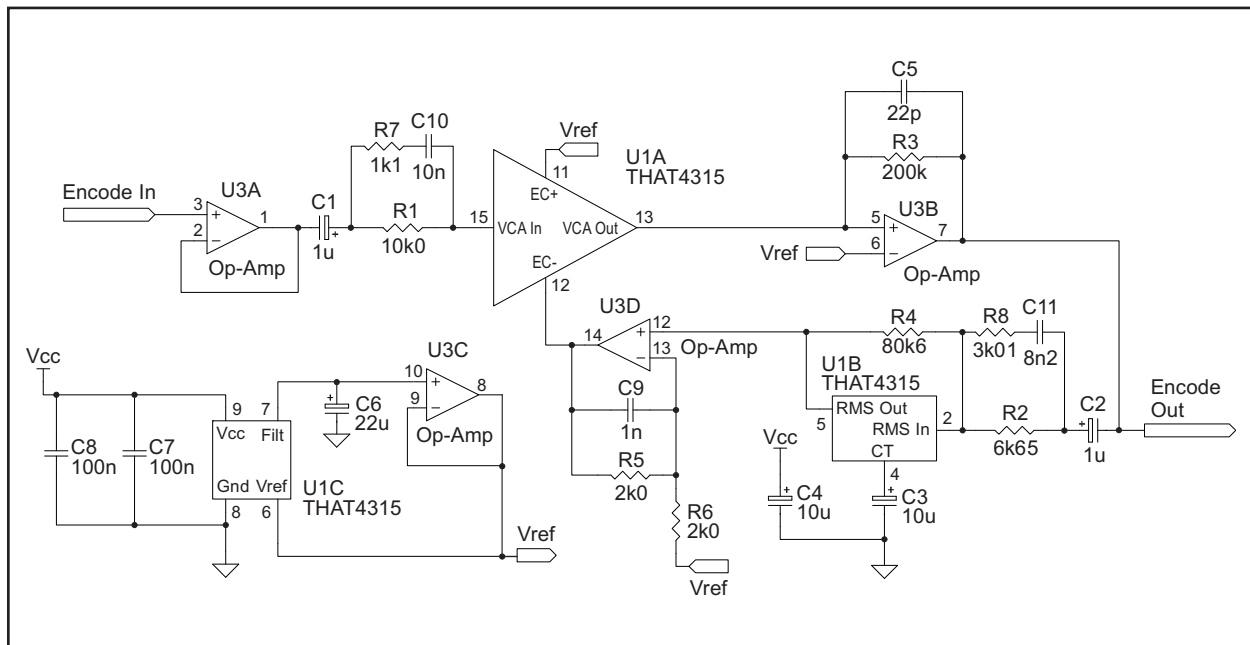

Figure 8. 3:1 Encoder circuit

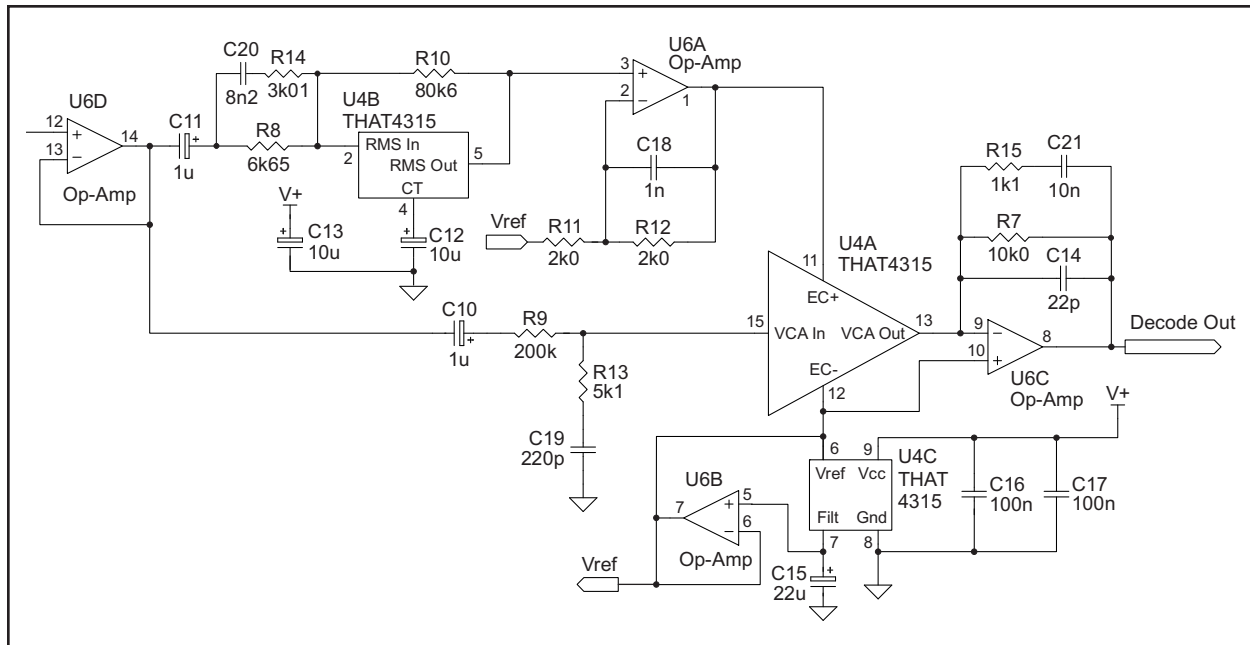

Figure 9. 3:1 Decoder circuit

Table 2 shows the transfer characteristics of this companding system. As before, the columns labeled Encoder VCA Gain, Encoder Out, Decoder VCA Gain, and Decoder Out use the equations derived previously in the section titled “The Mathematics of Log Based Companding Systems”. The values in the column labeled RMS In are derived using the equation:

$$I_{RMS In} = \frac{10 \frac{Encoder Out}{20}}{R_{RMS In}}$$

This table does not show the effect of R6 and R12, since this sort of break point behavior is difficult to model in a spreadsheet. However, it can readily be modeled in SPICE.

| Encoder In (dBV) | Encoder VCA Gain (ln dB) | Encoder Out/Decoder In (dBV) | $I_{RMS In}$ (mA) | Decoder VCA Gain (ln dB) | Decoder Out (dBV) |
|------------------|--------------------------|------------------------------|-------------------|--------------------------|-------------------|
| -0               | -35                      | -9                           | 0.1472            | 35                       | -0                |
| -10              | -28                      | -12                          | 0.1003            | 28                       | -10               |
| -20              | -21                      | -15                          | 0.0683            | 21                       | -20               |
| -30              | -15                      | -19                          | 0.0466            | 15                       | -30               |
| -40              | -8                       | -22                          | 0.0317            | 8                        | -40               |
| -50              | -1                       | -25                          | 0.0216            | 1                        | -50               |
| -60              | 5                        | -29                          | 0.0147            | -5                       | -60               |
| -70              | 12                       | -32                          | 0.0100            | -12                      | -70               |
| -80              | 19                       | -35                          | 0.0068            | -19                      | -80               |
| -90              | 25                       | -39                          | 0.0047            | -25                      | -90               |
| -100             | 32                       | -42                          | 0.0032            | -32                      | -100              |
| -110             | 39                       | -45                          | 0.0022            | -39                      | -110              |

Table 3. 3:1 compander transfer characteristics

You'll note that the VCA gain ranges that vary  $\pm 30$  dB are well within specification, as is the RMS detector input current. A maximum decoder output level of -9 dBV ( $0.5 V_{PEAK}$ ) was chosen in the event the user decides to use a diode clipper at the output of the VCA for over-modulation protection.

### 3:1 Compander

The configuration of THAT Corporation's “Analog Engine® ICs” allows compression/expansion ratios of other than 2:1, and this feature can be particularly advantageous in situations where RF bandwidth is at a premium. The circuits in Figures 8 and 9 demonstrate a basic 3:1 companding system. The topology of this system is reminiscent of the previous example.

The encoder shown in Figure 8 has a static gain of 26 dB;

$$A_V = \frac{200k\Omega}{10k\Omega} \cong 20$$

R4 in the encoder and R10 in the decoder are used to “floor out” the detectors at low levels for the reasons mentioned previously.

The values of R4 and R10 were chosen to cause the detector to stop responding to input signals that are 16 dB below level match. The value is determined by

$$R_{floor} = \frac{(16dB \cdot \frac{6mV}{dB})}{(7.5\mu A \cdot 10^{\frac{-16}{20}})} \cong 80.6k\Omega$$

Table 3 shows the transfer characteristics of this companding system. As before, the columns labeled

| Pin Name          | Pin Number |
|-------------------|------------|
| No Connection     | 1          |
| RMS IN            | 2          |
| No Connection     | 3          |
| C <sub>TIME</sub> | 4          |
| RMS OUT           | 5          |
| V <sub>REF</sub>  | 6          |
| FILTER            | 7          |
| GND               | 8          |
| V <sub>CC</sub>   | 9          |
| No Connection     | 10         |
| EC+               | 11         |
| EC-               | 12         |
| VCA OUT           | 13         |
| No Connection     | 14         |
| VCA IN            | 15         |
| No Connection     | 16         |

Table 4. THAT 4315 pin assignments

Encoder VCA Gain, Encoder Out, Decoder VCA Gain, and Decoder Out use the equations derived previously in the section titled “The Mathematics of Log Based Companding Systems”, and the values in the column labeled RMS In are derived using the equation:

$$RMS_{In} = \frac{10^{\frac{Encoder\ Out}{20}}}{R_{RMS\ In}}$$

Again, this table does not show the effect of R4 and R10, since this sort of break point behavior is difficult to model in a spreadsheet.

You'll note that the VCA gain ranges that vary  $\pm 39$  dB are still well within specification, as is the RMS detector input current, which now varies over an even smaller range. A maximum decoder output level of -9 dBV was retained in the event the user decides to use a diode clipper at the output of the VCA for over-modulation protection.

## Other Dynamics Processor Configurations

The same distinguishing features that make the 4315 so applicable to companding noise reduction systems also qualify it for application to dynamics processors of all types. This is even more so when the application must run from battery power. The 4315 is versatile enough to be used as the heart of a compressor, expander, noise gate, AGC, de-esser, frequency-sensitive compressor, and many other dynamics processors. It is beyond the scope of this data sheet to provide specific advice about any of these functional classes. We refer the interested

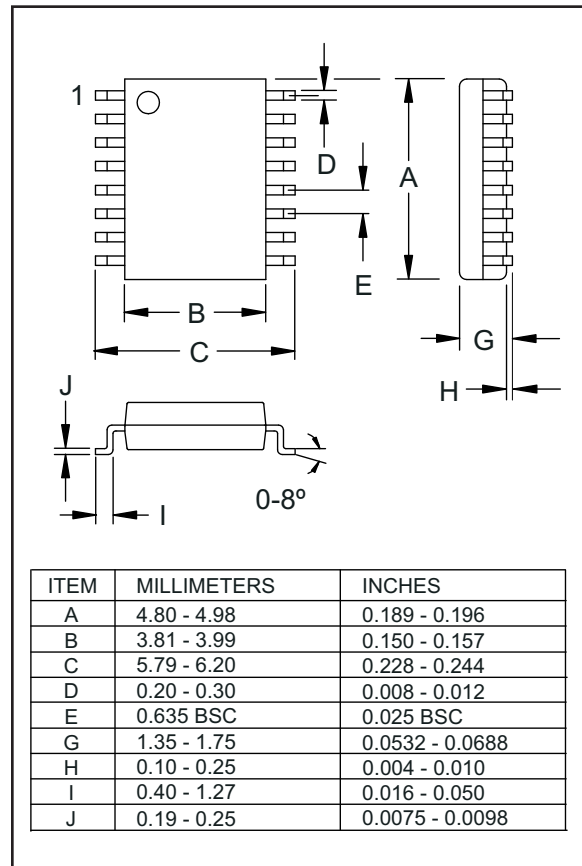

Figure 10. QSOP-16 surface mount package drawing

reader to THAT's applications notebooks volumes 1 and 2, which contain many circuits based on THAT's other VCAs and RMS level detectors, but are largely applicable to the 4315 with only minor variations. Of course, look for more applications information aimed specifically at the 4315 in the future.

## Where to go from here

The design of compander systems and dynamics processors is a very intricate art: witness the proliferation of first analog, then digital companding systems, and the many different dynamics processors available in the market today. In the applications section of this data sheet, we offer a few examples of companders as a starting point only. THAT Corporation's applications engineering department is ready to assist customers with suggestions for tailoring and extending these basic circuits to meet specific needs.

## Package Information

The THAT 4315 is available in a 16-pin QSOP package as shown in Figure 10.