

VFM Step-up DC/DC Converter

General Description

The RT9261B Series are VFM Step-up DC/DC converter ICs with ultra low supply current by CMOS process and suitable for use with battery-powered instruments.

The RT9261B IC consists of an oscillator, a VFM control circuit, a driver transistor (LX switch), a reference voltage unit, an error amplifier, resistors for voltage detection, and a LX switch protection circuit. A low ripple and high efficiency step-up DC/DC converter can be constructed with the RT9261B IC and only three external components.

The CE pin enables the circuit to set the standby supply current at a maximum of 0.5 μ A.

Ordering Information

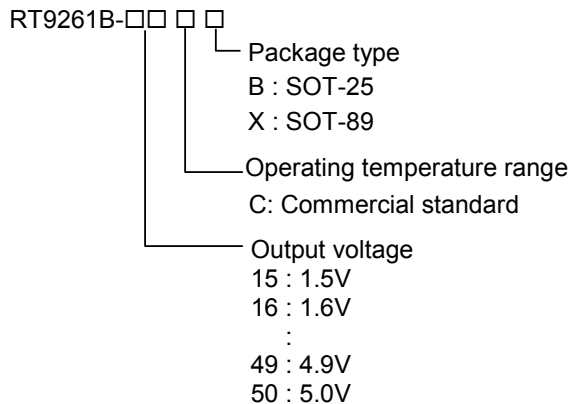

Features

- Minimal Number of External Components (Only an Inductor, a Diode, and a Capacitor)
- Ultra Low Input Current (6.5 μ A at Switch Off)
- Capable of Supplying 50mA Output Current with Internal Switch
- \pm 2% Output Voltage Accuracy
- Low Ripple and Low Noise
- Low Start-up Voltage, 0.8V at 1mA
- 80% Efficiency with Low Cost Inductor
- +50 ppm/ $^{\circ}$ C Low Temperature-Drift
- SOT-89 and SOT-25 Small Packages

Applications

- Power source for battery-powered equipment
- Power source for cameras, camcorders, VCRs, PDAs, pagers, electronic data banks, and hand-held communication equipment
- Power source for appliances, which require higher voltage than that of batteries used in the appliances

Pin Configurations

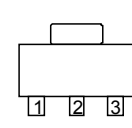
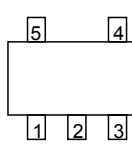
Part Number	Pin Configurations
RT9261B-□□CX (Plastic SOT-89)	<p>TOP VIEW</p>  <p>1. GND 2. VOUT (TAB) 3. LX</p>
RT9261B-□□CB (Plastic SOT-25)	<p>TOP VIEW</p>  <p>1. CE 2. VOUT 3. NC 4. GND 5. LX</p>

Typical Application Circuit

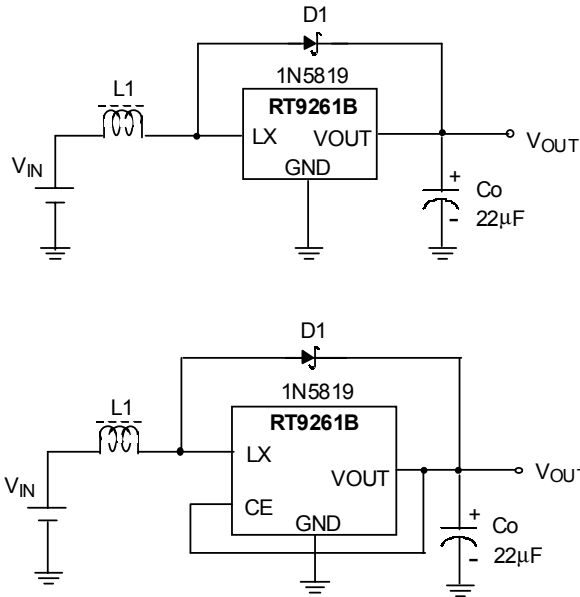

* L1 ranges from 27µH to 120µH

Pin Description

Pin No.		Pin Name	Pin Function
-xxCX	-xxCB		
1	4	GND	Ground
2	2	VOUT	Output Voltage
3	5	LX	Pin for Switching
--	1	CE	Chip Enable (Active High)
--	3	NC	No Connection

Function Block Diagram

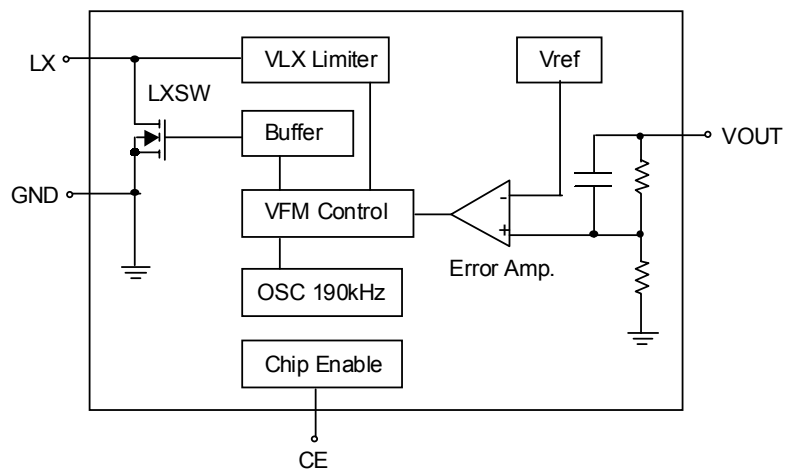

Absolute Maximum Ratings

- Output Voltage ----- 8V
- LX Pin Voltage ----- 8V
- CE Pin Voltage⁽¹⁾ ----- -0.3 to V_{OUT} +0.3V
- LX Pin Output Current ----- 400mA
- Power Dissipation, P_D @ T_A = 25°C
 - SOT-89 ----- 0.5W
 - SOT-25 ----- 0.25W
- Package Thermal Resistance
 - SOT-89, θ_{JC} ----- 100°C/W
 - SOT-89, θ_{JA} ----- 300°C/W
 - SOT-25, θ_{JA} ----- 250°C/W
- Operating Temperature Range ----- -20 to +85°C
- Storage Temperature Range ----- -65°C to 150°C
- Lead Temperature (Soldering, 10 sec.) ----- 260°C

Notes: (1) Applicable to RT9261B-xxCB

Electrical Characteristics (Refer to Fig. 1)

Parameter		Symbol	Test Conditions	Min	Typ	Max	Units
Output Voltage Accuracy		ΔV _{OUT}		-2	--	+2	%
Input Voltage		V _{IN}		--	--	7	V
Start-up Voltage		V _{ST}	I _{OUT} = 1mA, V _{IN} : 0 → 2V	--	0.8	1	V
Hold-on Voltage		V _{HO}	I _{OUT} = 1mA, V _{IN} : 2 → 0V	0.7	--	--	V
Input Current 1	V _{OUT} ≤ 3.5V ⁽¹⁾		To be measured at V _{IN} in continuous switching	--	24	36	μA
	3.5V < V _{OUT} ≤ 5V ⁽²⁾			--	36	45	
Input Current 2 ⁽¹⁾⁽²⁾			To be measured at V _{OUT} in switch off condition	--	6.5	10	μA
Input Current 3	V _{OUT} ≤ 3.5V ⁽¹⁾		To be measured at V _{IN} in no load (guaranteed by I ₁ and I ₂)	--	18	36	μA
	3.5V < V _{OUT} ≤ 5V ⁽²⁾			--	20	45	
LX Switching Current	V _{OUT} ≤ 3.5V ⁽¹⁾	I _{SWITCHING}	V _{LX} = 0.4V	120	--	--	mA
	3.5V < V _{OUT} ≤ 5V ⁽²⁾			160	--	--	
LX Leakage Current		I _{LEAKAGE}	V _{LX} = 6V	--	--	0.5	μA
Maximum Oscillator Frequency		F _{MAX}		140	190	240	KHz
Oscillator Duty Cycle		D _{OSC}	On (V _{LX} "L") side	65	75	85	%
Efficiency				--	80	--	%
V _{LX} Voltage Limit			LX switch on	0.65	0.8	1.0	V

Notes:

(1) V_{IN} = 1.8V, V_{SS} = 0V, I_{OUT} = 1mA, T_{opt} = 25°C, and External Circuit of Typical Application

(2) V_{IN} = 3V, V_{SS} = 0V, I_{OUT} = 1mA, T_{opt} = 25°C, and External Circuit of Typical Application

Electrical Characteristics (Refer to Fig. 2)

Parameter	Symbol	Test Conditions	Min	Typ	Max	Units
Output Voltage Accuracy	ΔV_{OUT}		-2	--	+2	%
Input Voltage	V_{IN}		--	--	7	V
Start-up Voltage	V_{ST}	$I_{OUT} = 1mA, V_{IN}: 0 \rightarrow 2V$	--	0.8	1	V
Hold-on Voltage	V_{HO}	$I_{OUT} = 1mA, V_{IN}: 2 \rightarrow 0V$	0.7	--	--	V
Efficiency			--	80	--	%
Input Current 1	$V_{OUT} \leq 3.5V^{(1)}$	To be measured at V_{IN} in continuous switching	--	24	36	μA
	$3.5V < V_{OUT} \leq 5V^{(2)}$		--	36	45	
Input Current 2 ^{(1) (2)}		To be measured at V_{OUT} in switch off condition	--	6.5	10	μA
Input Current 3	$V_{OUT} \leq 3.5V^{(1)}$	To be measured at V_{IN} in no load (guaranteed by I_1 and I_2)	--	18	36	μA
	$3.5V < V_{OUT} \leq 5V^{(2)}$		--	20	45	
LX Switching Current	$V_{OUT} \leq 3.5V^{(1)}$	$I_{SWITCHING}$ $V_{LX} = 0.4V$	120	--	--	mA
	$3.5V < V_{OUT} \leq 5V^{(2)}$		160	--	--	
LX Leakage Current	$I_{LEAKAGE}$	$V_{LX} = 6V$	--	--	0.5	μA
CE "H" Level		$V_{IN} = V_{OUT} * 0.9$	$0.4 \times V_{OUT}$	--	--	V
CE "L" Level		$V_{IN} = V_{OUT} * 0.9$	--	--	0.2	V
CE "H" Input Current		$CE = V_{OUT}$	--	--	0.5	μA
CE "L" Input Current		$CE = 0V$	-0.5	--	--	μA
Maximum Oscillator Frequency	F_{MAX}		140	190	240	KHz
Oscillator Duty Cycle	D_{OSC}	On (V_{LX} "L" side)	65	75	85	%
V_{LX} Voltage Limit		LX switch on	0.65	0.8	1.0	V

Notes:

(1) $V_{IN} = 1.8V, V_{SS} = 0V, I_{OUT} = 1mA, T_{opt} = 25^{\circ}C$, and External Circuit of Typical Application

(2) $V_{IN} = 3V, V_{SS} = 0V, I_{OUT} = 1mA, T_{opt} = 25^{\circ}C$, and External Circuit of Typical Application

Typical Operating Characteristics

Start-up/Hold-on Voltage vs. Output Current

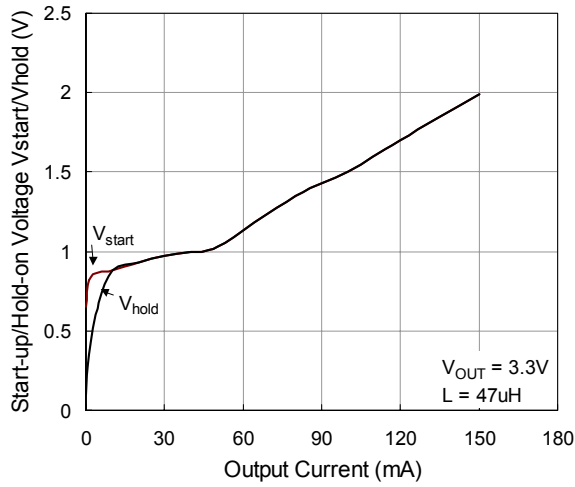

Output Voltage vs. Output Current

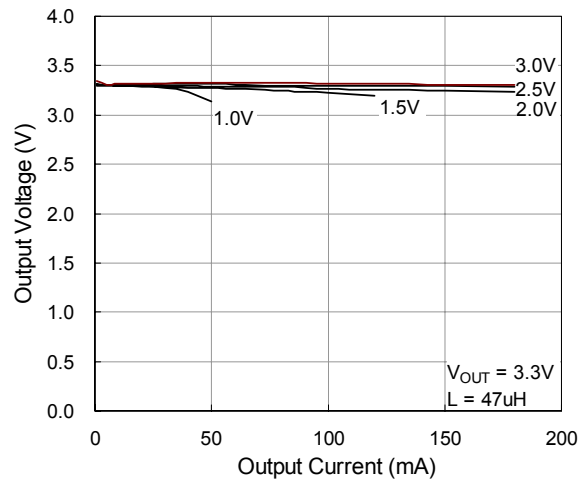

Output Current vs. Ripple Voltage

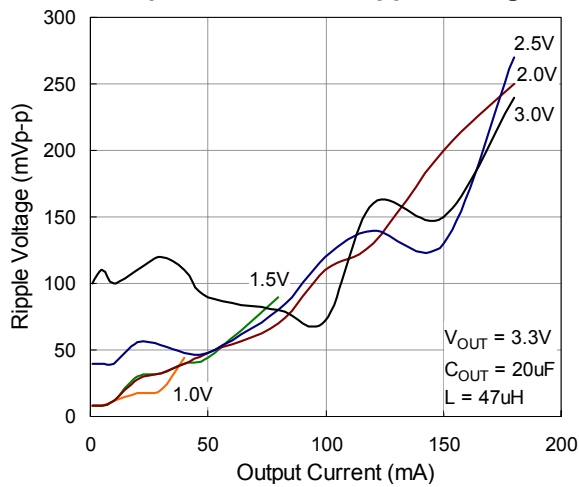

Output Current vs. Ripple Voltage

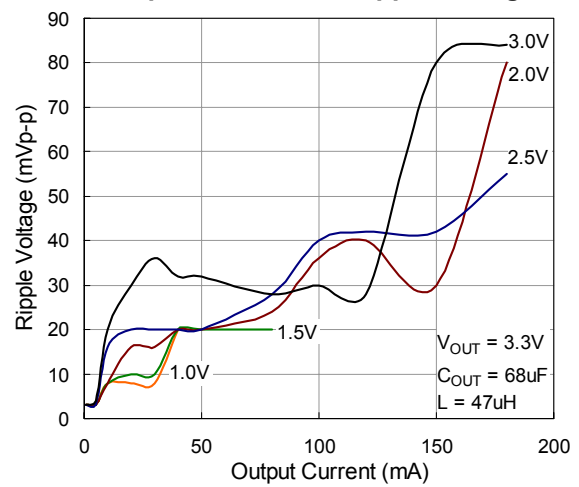

Output Current vs. Ripple Voltage

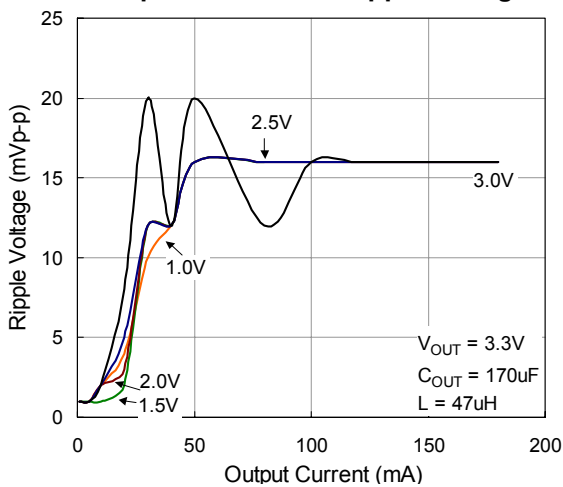

Efficiency vs. output Current

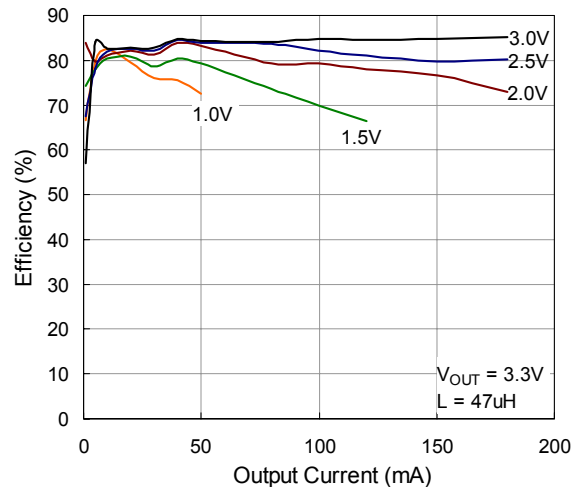

Start-up/Hold-on Voltage vs. Output Current

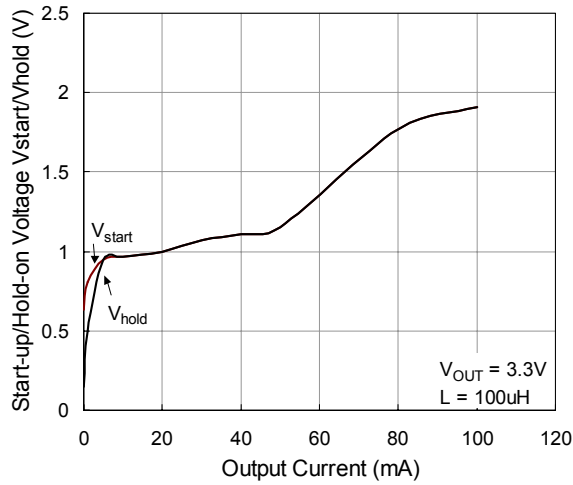

Output Voltage vs. Output Current

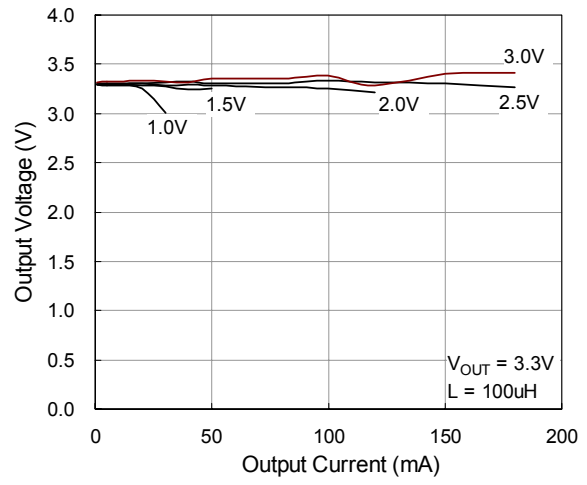

Output Current vs. Ripple Voltage

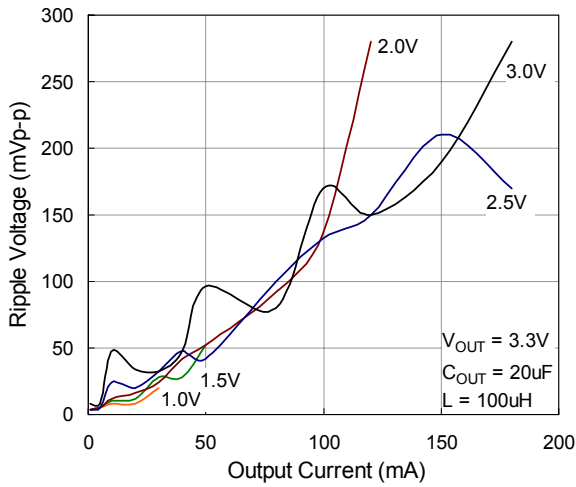

Output Current vs. Ripple Voltage

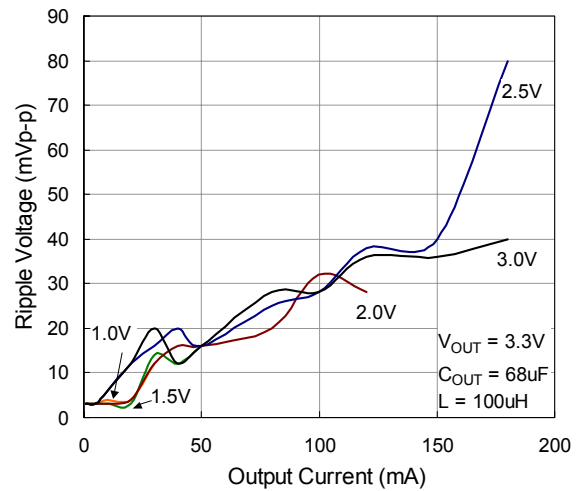

Output Current vs. Ripple Voltage

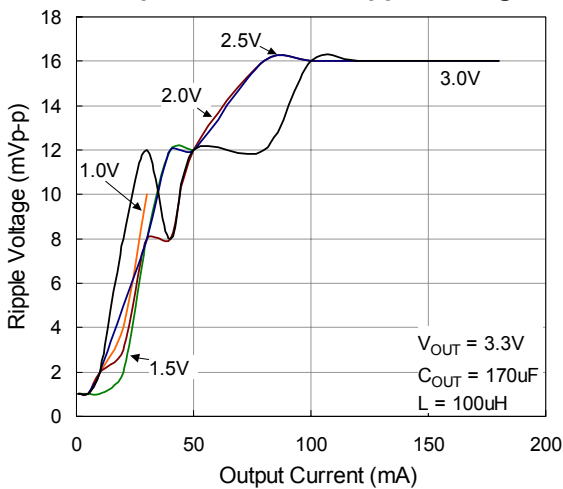

Efficiency vs. output Current

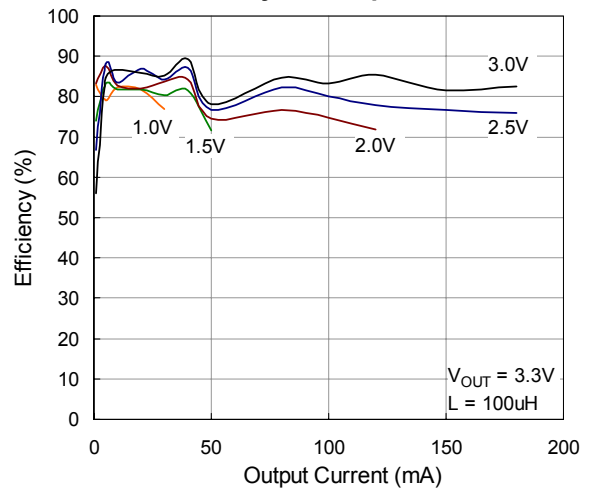

Package Information

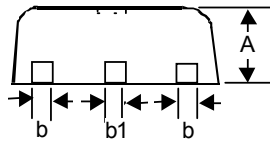
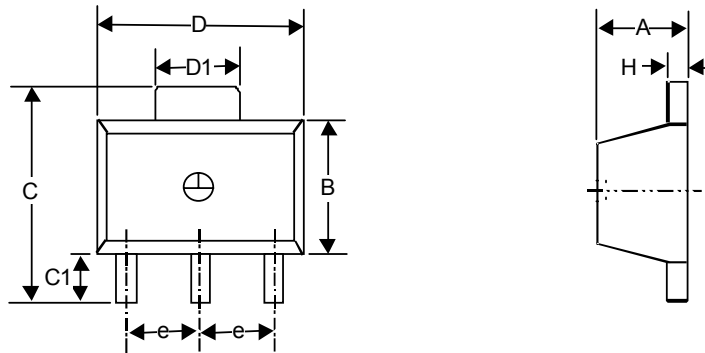

Symbol	Dimensions In Millimeters		Dimensions In Inches	
	Min	Max	Min	Max
A	1.397	1.600	0.055	0.063
b	0.356	0.483	0.014	0.019
B	2.388	2.591	0.094	0.102
b1	0.406	0.533	0.016	0.021
C	--	4.242	--	0.167
C1	0.787	1.194	0.031	0.047
D	4.394	4.597	0.173	0.181
D1	1.397	1.753	0.055	0.069
e	1.448	1.549	0.057	0.061
H	0.381	0.432	0.015	0.017

3-Lead SOT-89 Surface Mount

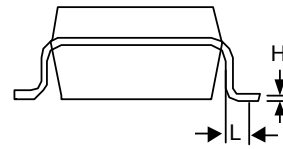
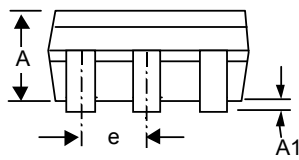
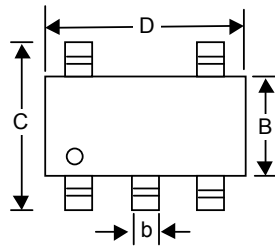

Symbol	Dimensions In Millimeters		Dimensions In Inches	
	Min	Max	Min	Max
A	0.889	1.295	0.035	0.051
A1	0.000	0.152	0.000	0.006
B	1.397	1.803	0.055	0.071
b	0.356	0.559	0.014	0.022
C	2.591	2.997	0.102	0.118
D	2.692	3.099	0.106	0.122
e	0.838	1.041	0.033	0.041
H	0.102	0.254	0.004	0.010
L	0.356	0.610	0.014	0.024

SOT-25 Surface Mount Package

RICHTEK TECHNOLOGY CORP.

Headquarter

6F, No. 35, Hsintai Road, Chupei City

Hsinchu, Taiwan, R.O.C.

Tel: (8863)5510047 Fax: (8863)5537749

RICHTEK TECHNOLOGY CORP.

Taipei Office (Marketing)

8F-1, No. 137, Lane 235, Paochiao Road, Hsintien City

Taipei County, Taiwan, R.O.C.

Tel: (8862)89191466 Fax: (8862)89191465

Email: marketing@richtek-ic.com.tw