

FEATURES

- Contains All The Active Components For A PCM Repeater Or Long Haul Line Receiver
- Low Voltage Operation (5.1V)
- Low Power Consumption (8.75mA Max)
- 2Mbps Operation Capability
- Dual Matched ALBO Ports
- Internal Adjustable Phase Shift Circuitry
- Extracted Clock Output
- Internal Shunt Regulator
- Temperature Independent Current Biasing

APPLICATIONS

- T1 PCM Repeater/Receiver
- T148C PCM Repeater/Receiver
- European 2.048Mbps PCM Repeater/Receiver
- Digital Multiplexers, CSUs, Switching Equipment
- ISDN Compatible Equipment: Fax Machines, Computers etc.

GENERAL DESCRIPTION

The XR-T56L22 is a very low power monolithic repeater/receiver IC designed for PCM carrier systems operating between 1.544Mbps and 2.37Mbps. The IC provides all the active circuitry required to implement one side of a PCM repeater. The XR-T56L22 features on-chip

adjustable phase shifting, an extracted clock output and an on-board shunt regulator. The very low power consumption of the device makes it ideal for long haul "tandem" repeater applications.

ORDERING INFORMATION

Part No.	Package	Operating Temperature Range
XR-T56L22AP	18 Lead 300 Mil PDIP	-40°C to +85°C
XR-T56L22AN	18 Lead 300 Mil CDIP	-40°C to +85°C
XR-T56L22AD	18 Lead 300 Mil Jedec SOIC	-40°C to +85°C

BLOCK DIAGRAM

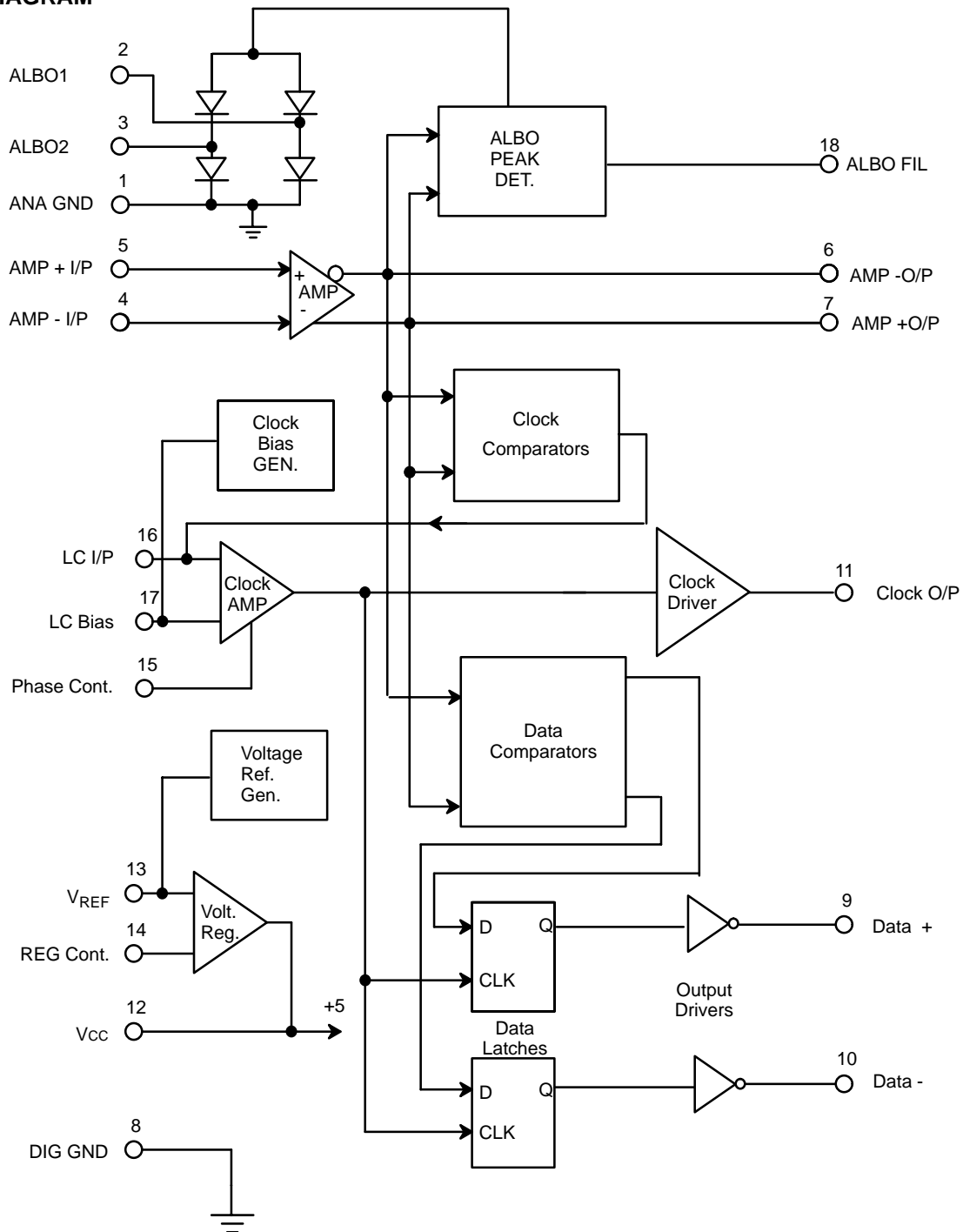
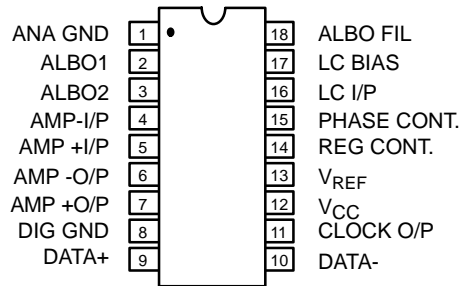
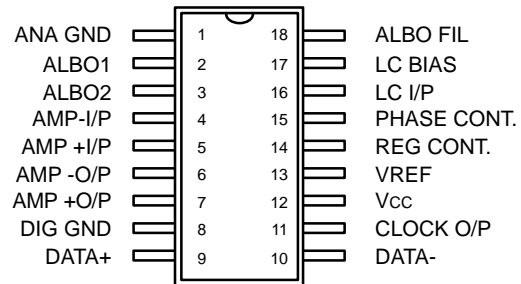

Figure 1. XT-T56L22 Block Diagram

PIN CONFIGURATION



18 Lead PDIP, CDIP (0.300")



18 Lead SOIC (Jedec. 0.300")

PIN DESCRIPTION

Pin #	Symbol	Description
1	ANA GND	Ground for Analog Sections of IC and Substrate.
2	ALBO 1	ALBO PORT 1 Output. Port impedance varies between 25W and 20kW proportional to input signal level.
3	ALBO 2	ALBO PORT 2 Output. Similar to pin 2.
4	AMP - I/P	Inverting Input of Signal Preamp $R_{IN} > 20k\Omega$.
5	AMP + I/P	Non-Inverting Input of Signal Preamp. $R_{IN} > 20k\Omega$.
6	AMP - O/P	Inverting Output of Signal Pre-amp. $R_{out} < 200\Omega$. DC level typically 3.2V.
7	AMP + O/P	Non-inverting Output of Signal Pre-amp. Similar to pin 6.
8	DIG GND	Ground for Digital Portion of IC.
9	DATA+	Positive Data Driver Output (Open Collector). $V_{OL} < 0.95V$ @ $I_{OUT} = 32mA$.
10	DATA-	Negative Data Driver Output (Open Collector). $V_{OL} < 0.95V$ @ $I_{OUT} = 32mA$.
11	CLOCK O/P	Phase Shifted Clock Output (Open Collector). Decouple to GND with 0.1mF if not required. With $R_{pull-up} = 1K$, $V_{OL} < 1.1V$ @ $I_{OUT} = 4mA$.
12	VCC	Input Pin of Shunt Regulator and Supply Pin for IC. For voltage feed applications the regulator must be disabled and a 5V + 5% supply connected. For line feed a current of 48-120mA is required. $I_{CC} < 8.75mA$ @ R_{ON} , ALBO = 25W typical.
13	VREF	Output Voltage of Internal Reference of Shunt Regulator. For parallel operation of regulators should be tied to pin 13 of 2nd T56L22 device. V_{REF} approxi-mately $V_{CC}/2$. Decouple to GND with 0.1mF.
14	REG CONT	Input Voltage of Shunt Regulator Amp. To inhibit regulator, pin should be tied to ground. For line feed operation decouple to GND with 0.1mF. For parallel operation of regulators tie pin 14 of 2nd T56L22 device. V_{REG} approximately V_{REF} .
15	PHASE CONT	Phase Shift Adjust Input. A resistor to GND from the pin allows adjustment of phase shift from 90S to approximately 05. R_P typical 1.8K to 1K. V_{phase} typical 340mV.
16	LC I/P	Clock Amplifier Input. Pulsed with current from clock comparator. Connect LC tank between 16, 17 for clock recovery. $I_{ckon} = -110mA$ typical.
17	LC BIAS	Clock Amplifier Reference Voltage. $V_{LC} = 3.6V$ typical.
18	ALBO FIL	Control Pin for ALBO Ports. Voltage developed across a capacitor on this pin defines ALBO on impedance $V_{ALBO} = 1.5V$ typical.

ELECTRICAL CHARACTERISTICS

Test Conditions: TA = -40°C to +85°C, VCC = 5.1V ± 5% unless otherwise specified - refer to test circuit (Figure 6).

Parameter	Pin	Min.	Typ.	Max.	Unit	Conditions
General						
Supply Voltage	12	4.85		5.35	V	Pin 12, 13 to V _{CC} ¹
Supply Current	12		7	8.75	mA	
Data Output Leakage Current	9, 10			100	μA	V _{pull-up} = 8V
ALBO Port Off Voltage	2, 3			0.1	V	V _{CC} = 5.35 V ¹
Amplifier Pin Voltage	4, 5	2.7	3.2	3.7	V	
Amplifier Pin Voltage	6, 7					
Amplifier						
Input Impedance	4, 5	40			KΩ	
Input Offset Voltage	4, 5	-10		10	mV	R _S = 8.2K ²
Input Bias Current	4, 5			5	μA	R _S = 8.2K ²
Input Offset Current	4, 5	-1		1	mV	R _S = 8.2K ²
Output Offset Voltage	6, 7	-50		50	Ω	R _S = 8.2K ²
Common Mode Rejection Ratio	4, 5, 6, 7	40			dB	
Output Volage Swing	6, 7	1.9			V	
Clock Amplifier						
Input Offset Voltage	17, 16	0.5		6	mV	R _S = 10K ³
Input Bias Current	17, 16			5	μA	⁴
AC Gain		40			dB	
-3db bandwidth		10			MHz	
Delay			35		ns	
ALBO						
ALBO Filter Resistance	18-1	31		57	KΩ	
ALBO Impedance Match	2, 3			10	%	
On Current	1	1.3		2.4	mA	
Drive Current	18	0.4		1.4	mA	
Maximum On Impedance	2, 3-1			25	Ω	⁵
Minimum Off Impedance	2, 3-1	20			KΩ	⁵

Notes

¹ Internal regulator disabled.

² Source Resistance.

³ R_S = Wou4d3 43wiw5qnd3 PIN 16 positive with respect to Pin 17

⁴ Pin 16 = Pin 17 = 3.6V

⁵ f_{test} = 1MHz

Specifications are subject to change without notice

ELECTRICAL CHARACTERISTICS (CON'T)

Parameter	Pin	Min.	Typ.	Max.	Unit	Conditions
Threshold Voltages						
ALBO Threshold +Ve	7, 6	1.4		1.6	V	1, 2
ALBO Threshold -Ve	7, 6	1.4		1.6	V	1, 2
ALBO Threshold Difference		-3		3	%	3
Clock Drive on Current + Ve		80		140	μA	4
Clock Drive on Current -Ve		80		140	μA	4
Clock Drive Difference		-3		3	%	3
Clock Threshold +Ve	7, 6	69		79	%	5
Clock Threshold -Ve	7, 6	69		79	%	5
Clock Threshold Difference		-3		3	%	3
Data Threshold +Ve	7, 6	41		50	%	3
Data Threshold -Ve	7, 6	41		50	%	5
Data Threshold Difference		-3		3	%	3
Data Output Stages						
Output Pulse Rise Time + Ve (Tr)	9			40	nS	10%-90% ⁶
Output Pulse Rise -Time-Ve(Tr)	10			40	nS	10%-90% ⁶
Output Pulse Fall Time+Ve(Tf)	9			40	nS	10%-90% ⁶
Output Pulse Fall Time -Ve (Tf)	10			40	nS	10%-90% ⁶
Output Pulse Width +Ve (Tw)	9	224		264	nS	at 50%
Output Pulse Width -Ve (Tw)	10	224		264	nS	at 50%
Output Pulse Width Difference (dT _w)		-12		12	nS	at 50%
Output Voltage (low) (VOL)	9, 10	0.6		0.95	V	6
Output Voltage Difference (VOL)	9, 10	-0.15		0.15	V	6

Notes

¹ Pk/pk voltage at Pins 6 and 7 of a 1MHz sine wave derived through amplifier and measured differentially.

² Pk/pk voltage at Pins 6 and 7 adjusted for a current increase of 2mA at pin 1.

³ Calculation only: percentage difference = $[\text{higher value}/\text{lower value}] - 1 \times 100\%$.

⁴ $V_6 - V_7$ adjusted to ALBO threshold voltage (Pin 16 = 3.6V)

⁵ Figure taken as a percentage of ALBO threshold.

⁶ Using a 130Ω pull up resistor between 9, 10 and VCC and 15pF capacitance to GND.

Specifications are subject to change without notice

ELECTRICAL CHARACTERISTICS (CONT'D)

Parameter	Pin	Min.	Typ.	Max.	Unit	Conditions
Clock Output Stage						
Output Pulse Rise Time (Tr)	11			40	ns	¹
Output Pulse Fall Time (Tf)	11			40	ns	
Output Pulse Width (Tw)	11	224		264	ns	
Shunt Regulator						
Output Voltage	12	4.85	5.1	5.35	V	Pin 13, 14 floating
Voltage Regulation Over Temp.	12		-0.02		%/°C	Pin 13, 14 floating
Load Regulation	12			0.027	%/mA	1mA to 100mA load

Note

¹ Using a 2K pull up resistor between 11 and VCC and 15pF capacitance to GND.

ABSOLUTE MAXIMUM RATINGS

Storage Temperature	-65°C to 150°C	Supply Voltage Surge (10ms)	25V
Operating Temperature	-40°C to 85°C	Data Output Voltage (pin 9, 10)	12V
Supply Voltage	-0.5 to 7V		

SYSTEM DESCRIPTION

With reference to the functional block diagram, the basic operation of the XR-T56L22 may be described as follows: The received bipolar signal, is applied to a linear amplifier and automatic equalizer. These circuits provide the necessary amount of gain and phase equalization to recover the transmitted data, and band limit the signal, to optimize repeater performance for near-end crosstalk produced by other systems operating within the same cable bundle.

The preamplifier output signals which are balanced and of opposite phase, are applied to the clock extraction and pulse regenerator circuits. Here they are rectified and then applied to a high Q resonant circuit which extracts the 1.544/2.048 Mbps frequency component from the received signal. This signal is then sliced and fed to an adjustable phase shift circuit. A second slicer is used to

control the time at which the output signals from the preamplifier are sampled by the pulse regenerator circuits. The phase shifted clock signal is made available as an output from the circuit for interface applications. The clock phase adjustment is performed with a single pin using an external resistor. Adjustment of the position of the clock sampling edge by the phase shift circuit allows performance of the pulse regenerator to be optimized. The pulse regenerator performs the sampling and data slicing to regenerate the appropriate output pulse. These pulses are applied to an external output transformer to create the bipolar signal that drives the next section of twisted pair.

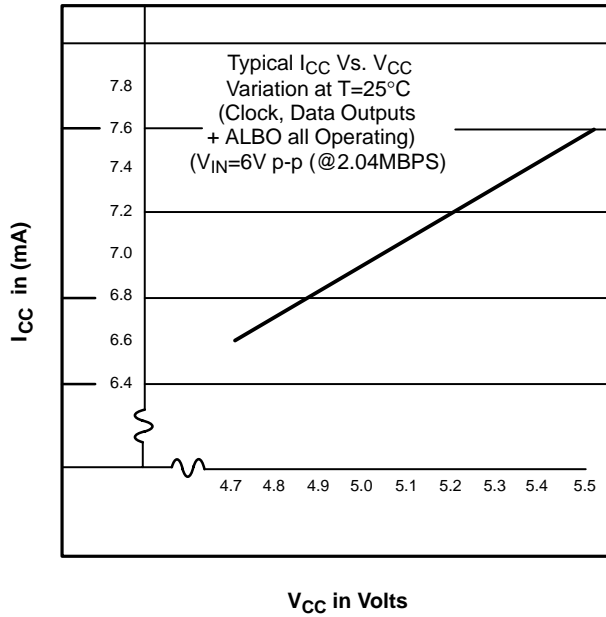

Figure 2. Supply Current Variation with V_{CC} (Regulator Inhibited)

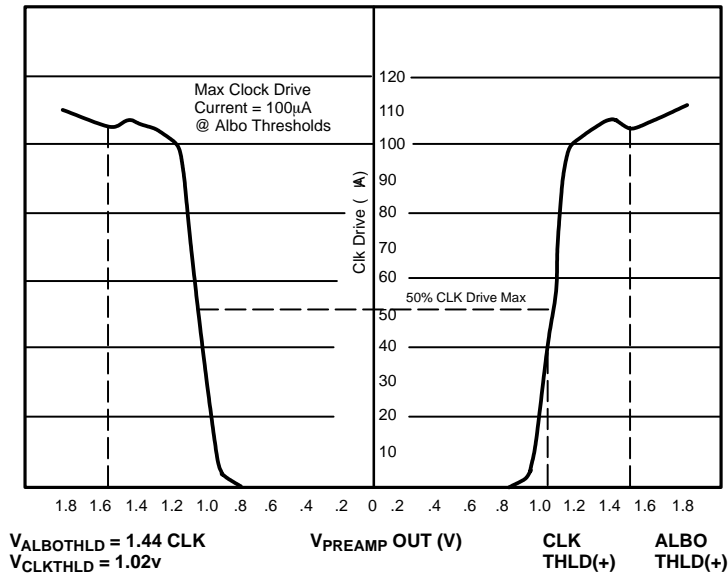

Figure 3. Clock Drive Current Against Preamp Output Voltage

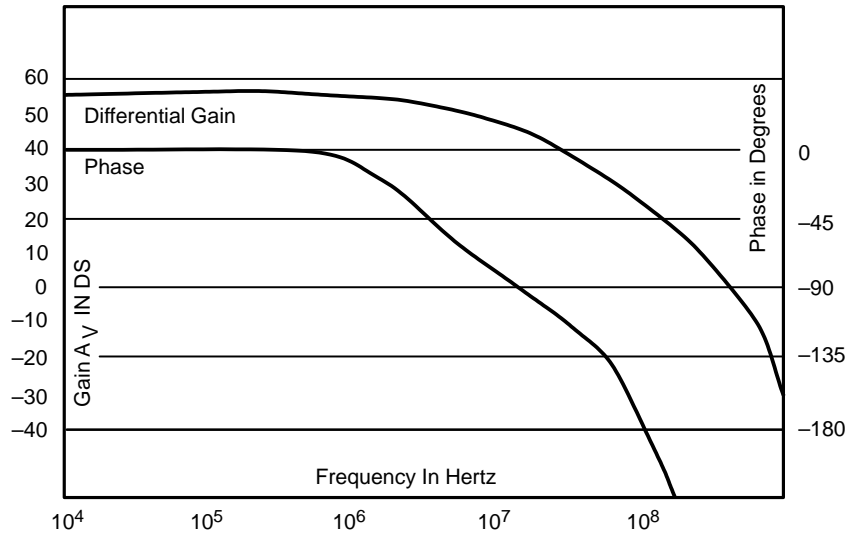

Figure 5. Preamp Gain/Phase Characteristics

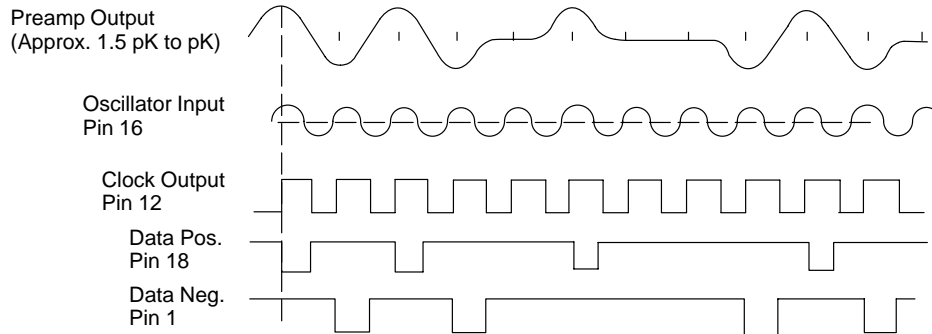

Figure 4. Typical T56L22 Waveforms

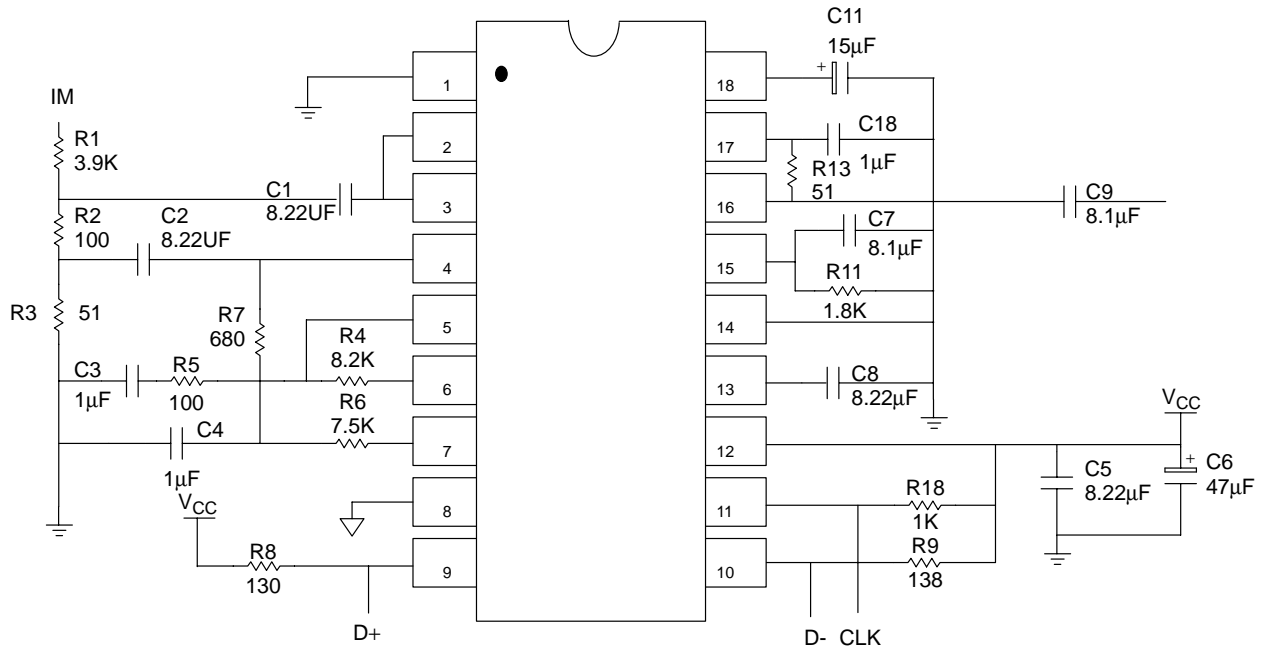
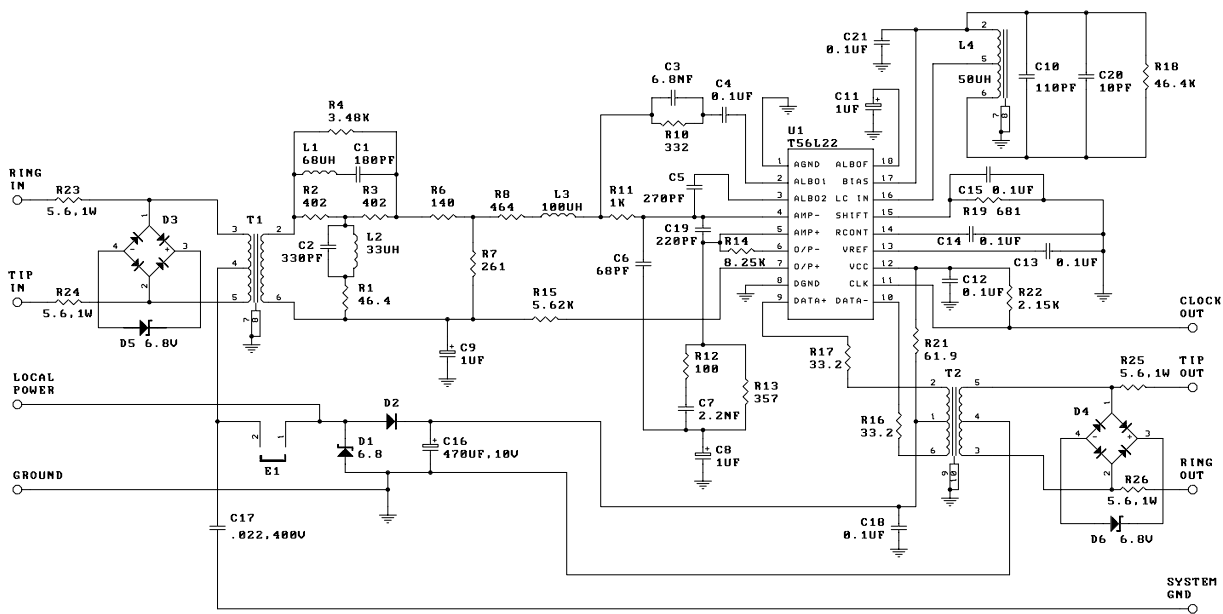

Figure 6. AC Parameter Test Circuit



- T1 - 1CT:2 (SCHOTT 67189558)
- T2 - 3CT:1CT
- L4 - 580UH ADJUSTABLE (SCHOTT 67143898)

Figure 8. XR-T56L22 E1 Evaluation Circuit

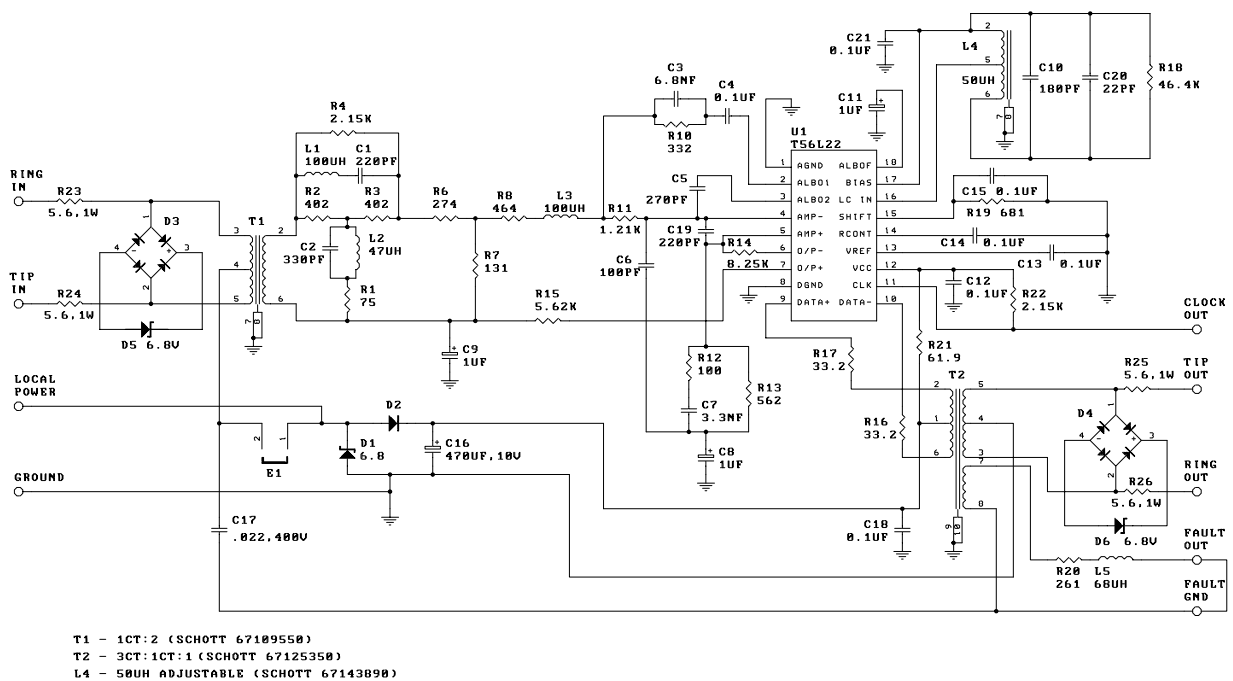
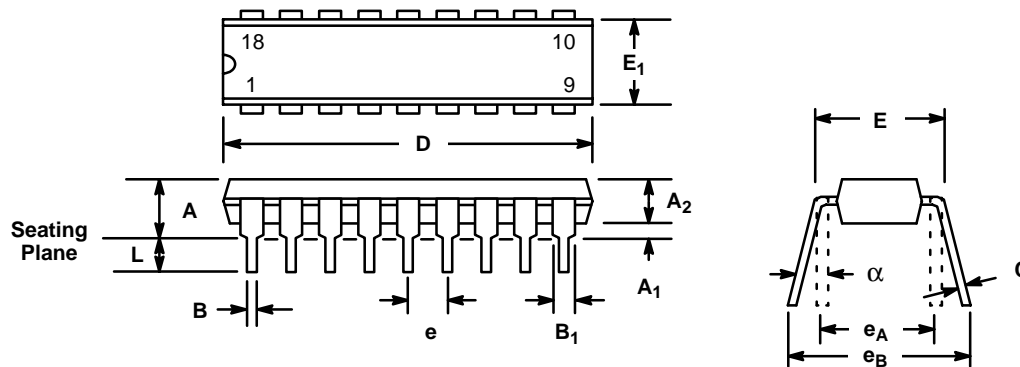

Figure 9. XR-T56L22 T1 Evaluation Circuit

18 LEAD PLASTIC DUAL-IN-LINE (300 MIL PDIP)

Rev. 1.00



SYMBOL	INCHES		MILLIMETERS	
	MIN	MAX	MIN	MAX
A	0.145	0.210	3.68	5.33
A ₁	0.015	0.070	0.38	1.78
A ₂	0.115	0.195	2.92	4.95
B	0.014	0.024	0.36	0.56
B ₁	0.030	0.070	0.76	1.78
C	0.008	0.014	0.20	0.38
D	0.845	0.925	21.46	23.50
E	0.300	0.325	7.62	8.26
E ₁	0.240	0.280	6.10	7.11
e	0.100 BSC		2.54 BSC	
e _A	0.300 BSC		7.62 BSC	
e _B	0.310	0.430	7.87	10.92
L	0.115	0.160	2.92	4.06
α	0°	15°	0°	15°

Note: The control dimension is the inch column

**18 LEAD CERAMIC DUAL-IN-LINE
(300 MIL CDIP)**

Rev. 1.00

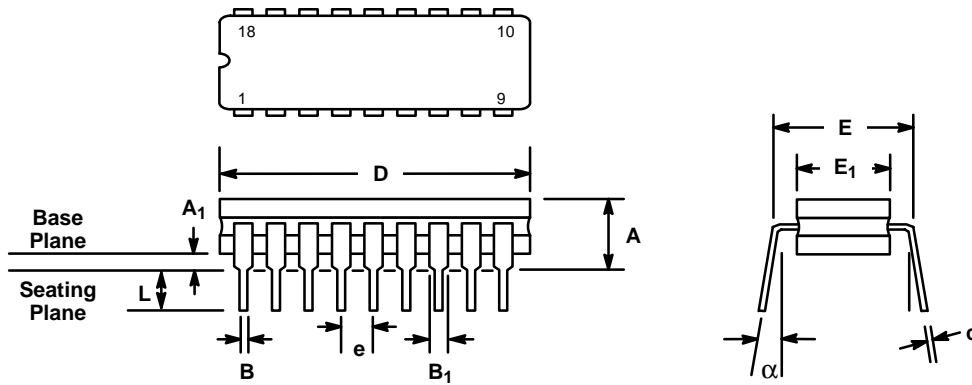

SYMBOL	INCHES		MILLIMETERS	
	MIN	MAX	MIN	MAX
A	0.100	0.200	2.54	5.08
A ₁	0.015	0.070	0.38	1.78
B	0.014	0.026	0.36	0.66
B ₁	0.045	0.065	1.14	1.65
c	0.008	0.018	0.20	0.46
D	0.860	0.960	21.84	24.38
E ₁	0.250	0.310	6.35	7.87
E	0.300 BSC		7.62 BSC	
e	0.100 BSC		2.54 BSC	
L	0.125	0.200	3.18	5.08
α	0°	15°	0°	15°

Note: The control dimension is the inch column

18 LEAD SMALL OUTLINE (300 MIL JEDEC SOIC)

Rev. 1.00

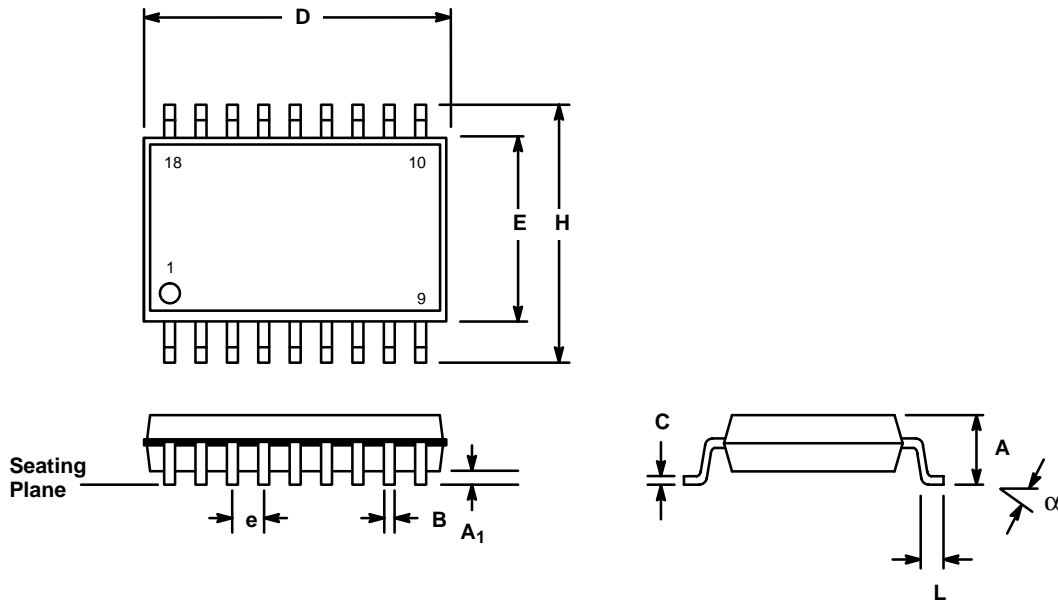

SYMBOL	INCHES		MILLIMETERS	
	MIN	MAX	MIN	MAX
A	0.093	0.104	2.35	2.65
A ₁	0.004	0.012	0.10	0.30
B	0.013	0.020	0.33	0.51
C	0.009	0.013	0.23	0.32
D	0.447	0.463	11.35	11.75
E	0.291	0.299	7.40	7.60
e	0.050 BSC		1.27 BSC	
H	0.394	0.419	10.00	10.65
L	0.016	0.050	0.40	1.27
α	0°	8°	0°	8°

Note: The control dimension is the millimeter column

Notes

NOTICE

EXAR Corporation reserves the right to make changes to the products contained in this publication in order to improve design, performance or reliability. EXAR Corporation assumes no responsibility for the use of any circuits described herein, conveys no license under any patent or other right, and makes no representation that the circuits are free of patent infringement. Charts and schedules contained here in are only for illustration purposes and may vary depending upon a user's specific application. While the information in this publication has been carefully checked; no responsibility, however, is assumed for inaccuracies.

EXAR Corporation does not recommend the use of any of its products in life support applications where the failure or malfunction of the product can reasonably be expected to cause failure of the life support system or to significantly affect its safety or effectiveness. Products are not authorized for use in such applications unless EXAR Corporation receives, in writing, assurances to its satisfaction that: (a) the risk of injury or damage has been minimized; (b) the user assumes all such risks; (c) potential liability of EXAR Corporation is adequately protected under the circumstances.

Copyright 1997 EXAR Corporation
Datasheet June 1997

Reproduction, in part or whole, without the prior written consent of EXAR Corporation is prohibited.