



Technical Reference Note APA18T04 DC - DC Series



APA18T04 – 3.0-5.5Vin, 18A, Non-isolated DC – DC SIP Converter

The single output APA18T04 is a non-isolated, 60W, SIP footprint Point-of-Load (POL) DC/DC converter. The new APA18T04 series can deliver an adjustable output voltage range from 0.75V – 3.3V at 18 Amps (A) with efficiency as high as 93.5%, and the input voltage range is from 3.0 – 5.5V.

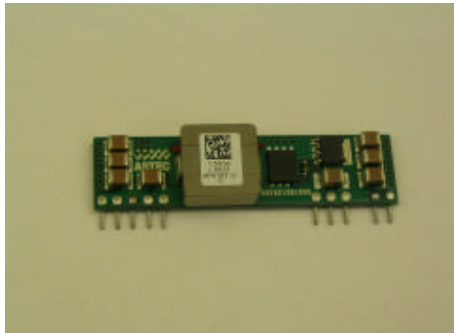

Special Features

- Point of Load (POL) applications
- High current slew rate at 1A/uS
- Industry standard footprint
- Open frame SIP
- -40°C to +85°C Ambient operating temperature
- Positive enable function
- Low output ripple and noise
- Adjustable output voltage through external resistor programming
- Regulation to zero load

Environment Specifications

-40°C to +85°C Operating temperature
-40°C to +125°C Storage temperature
MTBF: >1 million hours
ROHS Compliant

Electrical Parameters

Input

Input range	3.0 to 5.5 VDC
Input Surge	6V / 100ms
Efficiency	95% @ 3.3Vo (Typical)

Output

Load current	18Amax (Po £ 60W)
Line Regulation	< 0.5%
Load Regulation	
0.75Vo	10mV
0.75 < Vo < 3.3V	15mV
3.3V ≤ Vo	30mV

Noise / Ripple 50mV_{p-p} max

Enable TTL compatible

Transient Response 300mV typical deviation
(with output cap For load change of 50% step
100uF Tantalum + Between 10% to 100% of load
1uF ceramic) 100uS(max) recovery

Remote Sense +10% Vo
Turn on input voltage 2.7 – 3.0V (Typ)
Over Temperature 120°C
Protection

OCP/OTP Hiccup – auto recovery

Safety

UL, cUL 60950 Recognized
TUV EN60950 Licensed

Model: APA18T04 Series

Date: Aug 2005

SH 1 OF 26



Technical Reference Note
APA18T04 DC - DC Series



APA18T04 SERIES

THIS TECHNICAL REFERENCE NOTES COVERS THE SPECIFICATIONS FOR A SINGLE OUTPUT, OPEN-FRAME, NON-ISOLATED DC-DC CONVERTER WITH ADJUSTABLE OUTPUT FROM 0.75V TO 3.3V HAVING 59.4W MAXIMUM OUTPUT POWER WHEN OPERATED FROM A NOMINAL 5 VDC SOURCE. THE MECHANICAL OUTLINE IS 50.8MM X 12.7MM X 8.1MM AND OFFERED IN SIP TERMINATION. MODELS IN THE FAMILY ARE OUTLINED BELOW.

MODEL NUMBER	SIS CODE	Vin range	Vout/Iout	MODEL ID NO
APA18T04-9	APA18T04-9	3V – 5.5V	0.75V – 3.3V / 18A*	D892
APA18T04-9H	APA18T04-9H	3V – 5.5V	0.75V – 3.3V / 18A*	D893

*Options:

Suffix	Option
-9	Vo Trim, Vertical Mounting Pin, RoHS compliance
-9H	Vo Trim, Horizontal Mounting Pin, RoHS compliance

Note: * 18A maximum output current with total power limited to 59.4W. Output voltage is set to 0.7525V (fty default).



Technical Reference Note APA18T04 DC - DC Series



Electrical Specifications

The product shall comply with the requirements of this specification for all valid conditions of line input voltage, load current, temperature and other environmental conditions, unless otherwise specified in this document.

Description	
External Input Fuse ^{1,2}	LITTLEFUSE 314025(25A fast acting fuse)
External Input Capacitance	As specified by Appendix A2, and 4
External Output Capacitance	As specified by Appendix A3, and 4.
+V _{IN}	3.3Vdc/5Vdc (nominal Input Voltage)
Enable	Open
GND	Return for both V _{IN} and V _O
Trim	Resistor Programming [See App A6]
+V _{out}	Output Pin connected to Load
Airflow ³	200LFM/300LFM
T _A (Ambient Temperature)	-40°C to 85°C

- NOTE:
1. Refer to Appendix A4 for typical application circuit.
 2. The converter is not internally fused; Engineering needs to specify a fuse appropriate to the package size of the converter.
 3. Refer to Appendix A1 for correct airflow and module orientation & Appendix B for the derating curves of different airflow.



Technical Reference Note APA18T04 DC - DC Series



ABSOLUTE MAXIMUM RATINGS

Stresses in excess of the absolute maximum ratings can cause permanent damage to the device. Functional operation of the device is not implied at these or any other conditions in excess of those given in the operational sections of this specification. Exposure to absolute maximum ratings for extended periods can adversely affect device reliability. The converter shall be designed, labeled and safety approved for maximum continuous rating as follows:

Parameter	Device	Symbol	Min	Typ	Max	Unit
Input Voltage						
Continuous	All	V_{IN}	-0.3	-	6	Vdc
Transient (100ms)		$V_{IN,trans}$	-	-	8	
Operating Temperature	All	T_a	-40	-	85	°C
Storage Temperature	All	T_{STG}	-55	-	125	°C
Operating Humidity	All	-	10	-	85	%
Max Voltage at Enable Pin	All		-	-	12	Vdc
Max Output Power	All		-	-	59.4	W

4.3 INPUT SPECIFICATIONS

Parameter	Device	Symbol	Min	Typ	Max	Unit
Operating Input Voltage Range	All	V_{IN}	3.0	3.3/5.0	5.5	Vdc
Input Under-Voltage Lock-out						
T_ON Threshold	0.75V=V _o		2.7	2.9	3.0	Vdc
T_OFF Threshold	<2.5V		2.4	2.6	2.7	
Input Current	T04	I_{IN-MAX}	-		18.0	A
<small>($V_{IN} = V_{IN,Min}$; $I_O = I_{O,Max}$)</small>						
Max P _{diss} @ I _O = 0A	V _o :3.3V		-	-	0.5	W
<small>($V_{IN} = V_{IN,Nom}$, $T_A=25^{\circ}C$)</small>						
Input Ripple Current ¹	All	I_{r1}	-	-	300	mAp-p
<small>5Hz to 20MHz</small>						
Input Voltage Rise Time	All		NA	-	-	V/ms
<small>10% to 90% of V_{out}</small>						
Inrush Current	All		NA	-	-	Apk
<small>dV_{IN}/dt</small>						

NOTE: 1. External input capacitance required. See Input Ripple Current test measurement setup on Appendix A2.



Technical Reference Note APA18T04 DC - DC Series



OUTPUT SPECIFICATIONS

Parameter	Device	Symb	Min	Typ	Max	Unit
Output Voltage Set point $V_{IN} = V_{IN, MIN}$ to $V_{IN, MAX}$; $I_O = I_{O, max}$		$V_{O, SET}$	0.74	0.7525	0.76	Vdc
Output Regulation Line: $V_{IN} = V_{IN, min}$ to $V_{IN, max}$ Load: $I_O = I_{O, min}$ to $I_{O, max}$ Temp: $T_A = -40\text{ }^\circ\text{C}$ to $+85\text{ }^\circ\text{C}$	All 0.75V $0.75 < V_O < 3.3V$ $3.3V \leq V_O$ All	- - - -	- - - -	- - - -	0.5 10.0 15.0 30.0 1.0	% mV mV mV %
Ripple and Noise ² Peak-to-Peak: (5Hz to 20MHz)	All	-	-	25	55	mVp-p
Output Current and output power ³	All	I_O P_o	0 0	- -	18 59.4	A W
External Load Capacitance Cap ESR = 1 mO Cap ESR = 10 mO	All				1000 5000	μF μF
Output Current-limit Inception $V_{OUT} = 90\% V_{O, SET}$ ^{4,10}	All	I_O	18.5	-	50	A
Over Temperature Range ⁶ (AVG. PCB TEMP)	All	-	100	110	120	$^\circ\text{C}$
Efficiency ⁹ $V_{IN} = 5V$, $I_O = I_{O, MAX}$; $T_A = 25^\circ\text{C}$	0.75V 1.20V 1.50V 1.80V 2.50V 3.30V	η η η η η η	78.4 83.7 86.4 88 91 93	82 87 89 90 92.5 95		% % % % % %
Turn-On Response Time ⁵ $V_{IN} = V_{IN-MIN}$ to V_{IN-MAX}	All	-	2.0		6.0	ms
Enable to Output Turn-ON Delay $V_{IN} = V_{IN-MIN}$ to V_{IN-MAX} $I_O = I_{O, MIN}$ to $I_{O, MAX}$	All	-	-	-	8	ms
+ V_{IN} to Output Turn-On Delay Enable Pin: Active $V_{IN} = V_{IN-MIN}$ to V_{IN-MAX} $I_O = I_{O, MIN}$ to $I_{O, MAX}$	All	-	-	-	20.0	ms
Switching Frequency	All	-	250	300	350	KHz
Output Overshoot at T-on / T-off Passive Resistive Full Load	All	-	-	-	5	% V_O

Model: APA18T04 Series

Date: Aug 2005

SH 5 OF 26



Technical Reference Note APA18T04 DC - DC Series



OUTPUT SPECIFICATIONS

Parameter	Device	Symbol	Min	Typ	Max	Unit
Dynamic Response ⁶ (C _O = 100uF Tantalum + 1uF ceramic) Load Change of 50% step anywhere between 10% to 100% of rated load		$\Delta I_O/\Delta t$	-	2.5	-	A/ μ s
Peak Deviation	All	-	-	300	350	mV
Settling Time to V _{O, Nom} <5%		-	-	100	150	μ s
Peak deviation						
Dynamic Response ⁶ (C _O = 150uF x2 Special Polymer Aluminum Capacitors+10uF Tantalum Cap. +1uF Ceramic Cap.) Load Change of 50% step anywhere between 10% to 100% of rated load		$\Delta I_O/\Delta t$		2.5		A/ μ s
Peak Deviation	All			150	200	mV
Settling Time to V _{O, Nom} <5%				150	200	μ s
Peak deviation						
Output Voltage Trim Range ⁷	All		0.74	-	3.63	V
Remote Sense ⁸	All			-	10%	V
Output Enable ON/OFF						
Positive Enable *	All					
Enable Pin Voltage: Mod-ON		-	2.4	-	12.0	V
Mod-OFF		-	-0.7	-	0.8	V

* Module is enabled with Enable Pin open

NOTE: 2. Refer to Appendix A3 for the Output Ripple and Noise Test Measurement Setup.

3. Output Power Derating applies at elevated temperature. See Appendix B for the Derating Curves.

4. OCP and OTP are in hiccup mode. The converter will auto restart once the fault is removed. OCP is not precise with Vin varying. OTP along with OCP will protect the converter under typical overload condition.

5. Measure output rise time from 10% V_O to 90% V_O. See Appendix A5.

6. Load step response shall be measured at the load side of the output capacitors. See Appendix A4 for the output and input cap requirement.

7. See appropriate Trim Equation and configuration in Appendix A6. The voltage difference between input and output must be greater than 0.7V.

8. The combination of remote sense and output trim adjust cannot exceed 0.25V.

9. A tested correlation factor may be used to justify the minimum efficiency specification to facilitate manufacturing test for the units under test with contact (non-soldering) type of connections, for example pogo pin's type of connection.

10. Under 25°C.

Model: APA18T04 Series

Date: Aug 2005

SH 6 OF 26

APPENDIX A1: CONVERTER ORIENTATION WRT TO AIRFLOW

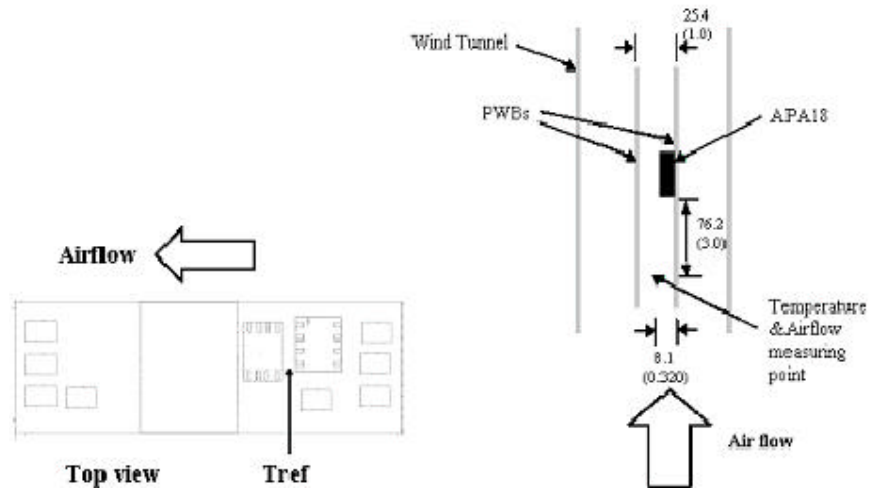

Figure 1. Airflow Orientation and Thermal Test Setup

APPENDIX A2: INPUT REFLECTED RIPPLE TEST SETUP

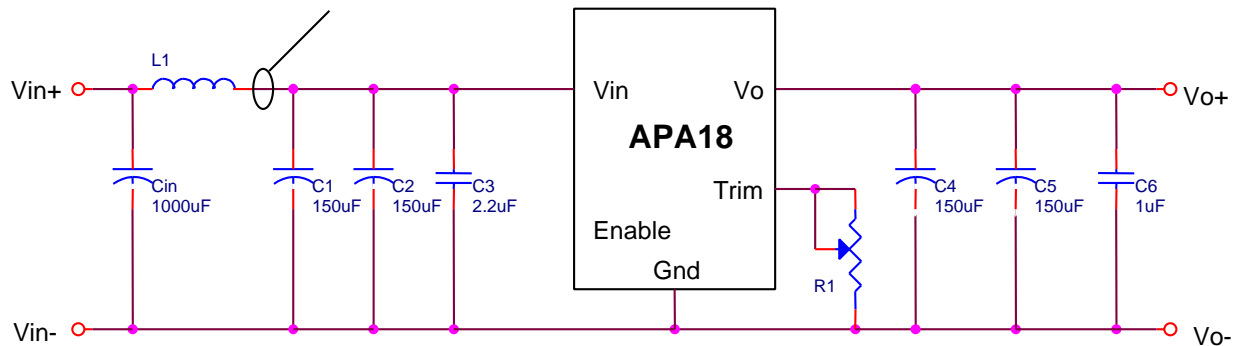

Figure 2. Input Reflected-ripple current Test Setup.

Note: Measure input reflected-ripple current with a simulated source inductance (L_{test}) of 1uH. Capacitor C_s offsets possible battery impedance. Measure current as shown above.

Input capacitors:

C1,C2: Use 150uF/6.3V special polymer(Sanyo 6TPE150M ,or Panasonic EEFUE0J151R).C3: 2.2uF/6.3V Ceramic

APPENDIX A3: OUTPUT RIPPLE TEST SETUP

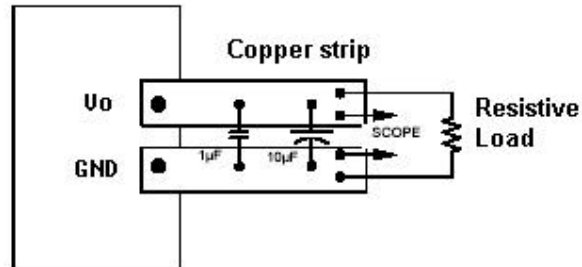

Figure 3. Peak-to-Peak Output Noise Measurement Test Setup.

Note:

- (1) Use a 1 μ F @50V X7R ceramic capacitor and a 10 μ F @ 10V tantalum capacitor.
- (2) Use 2 x 150 μ F/6.3V special polymer(Sanyo 6TPE150M ,or Panasonic EEFUE0J151R)
- (3) Scope measurement should be made using a BNC socket. Position the load between 51 mm and 76 mm (2 in. and 3 in.) from module.

APPENDIX A4: TYPICAL APPLICATION CIRCUIT

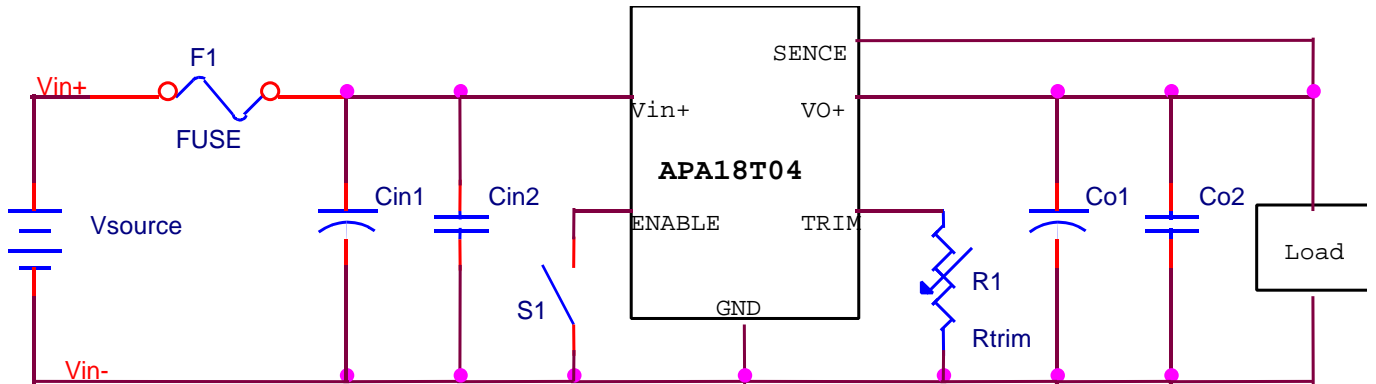

Figure 4. Typical Application Circuit

F1: Fuse: Use external fuse (Fast-acting type 25A) for each unit.

Input capacitors:

Cin1: 150uF/6V x 2 special polymer (Sanyo 6TPE150M, or Panasonic EEFUE0J151R)

Cin2: 47uF/10V x2 Ceramic

Output capacitors:

Co1: 150uF/6.3V x2 special polymer (Sanyo 6TPE150M, or Panasonic EEFUE0J151R)

Co2: 1uF/6.3V ceramic

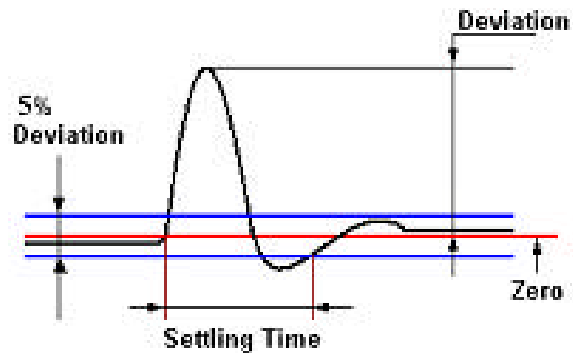

Figure 5. Dynamic deviation and settling time



APPENDIX A5: TIMING DIAGRAM

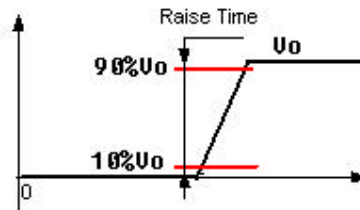

Figure 6. Timing diagram

APPENDIX A6: OUTPUT TRIM REQUIREMENT

Output voltage adjustment is accomplished by connecting an external resistor between the Trim Pin and Ground Pin terminals. Resistance and Output voltage relationship is established by Equation 1. If Trim pin is left open – default $V_o = 0.7525V$

TRIM-UP EQUATION:
$$R_{trim} = \left(\frac{21070}{V_o - 0.7525} - 5110 \right) \Omega$$

Where R_{trim} is the resistance value in ohms and V_o is the output voltage desired.

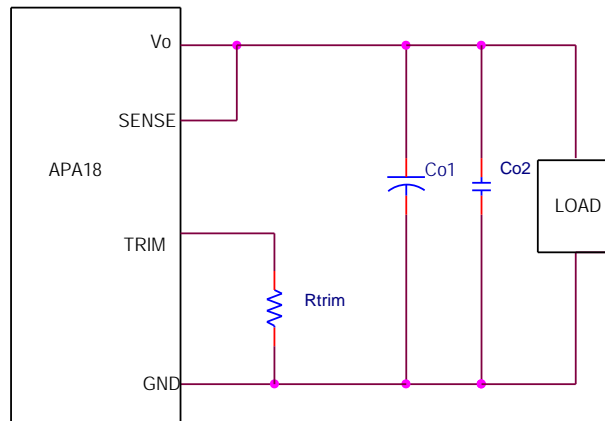

Figure 7. Trim UP test configuration (Pin Side Up)

$V_{o, set}$ (V)	0.7525	1.2	1.5	1.8	2.5	3.3
Rtrim (k Ω) from Equation	open	41.97	23.08	15	6.95	3.16
Rtrim (k Ω) from E96	open	42.2	23.2	15	6.98	3.16



Technical Reference Note APA18T04 DC - DC Series



APPENDIX B: THERMAL DERATING CURVES

NOTE: These curves are limited by OTP.

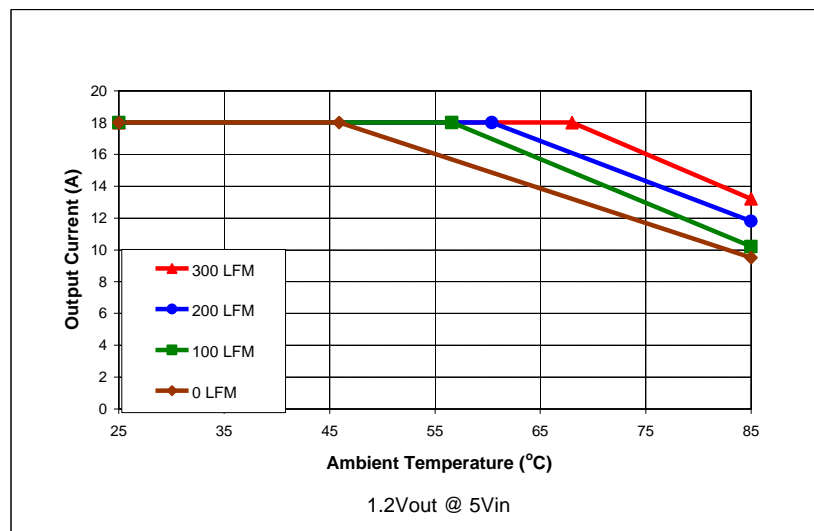
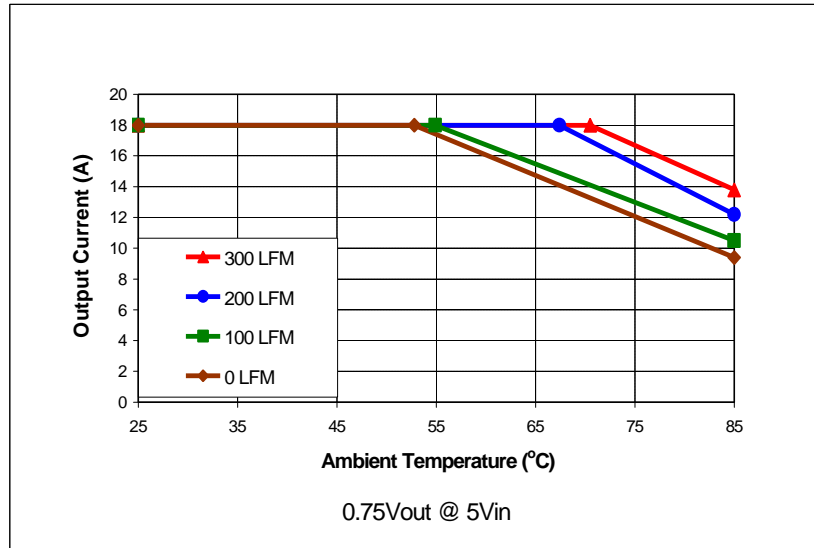

Model: APA18T04 Series

Date: Aug 2005

SH 13 OF 26



Technical Reference Note APA18T04 DC - DC Series

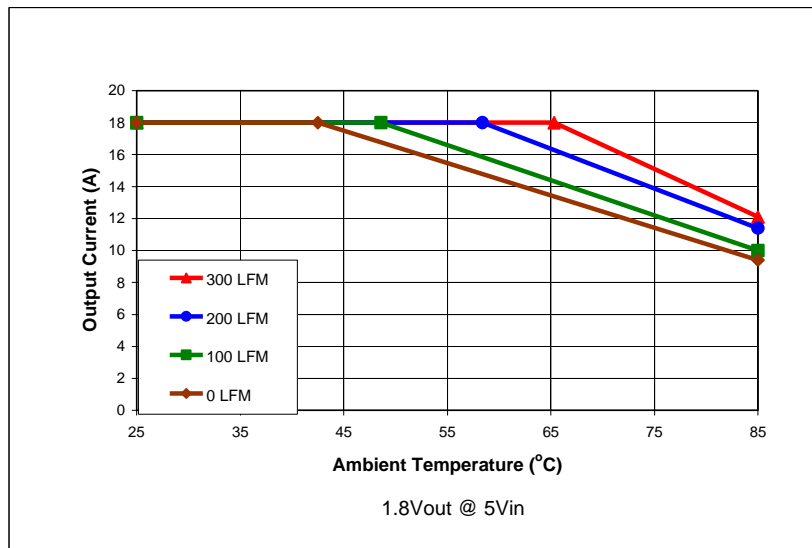
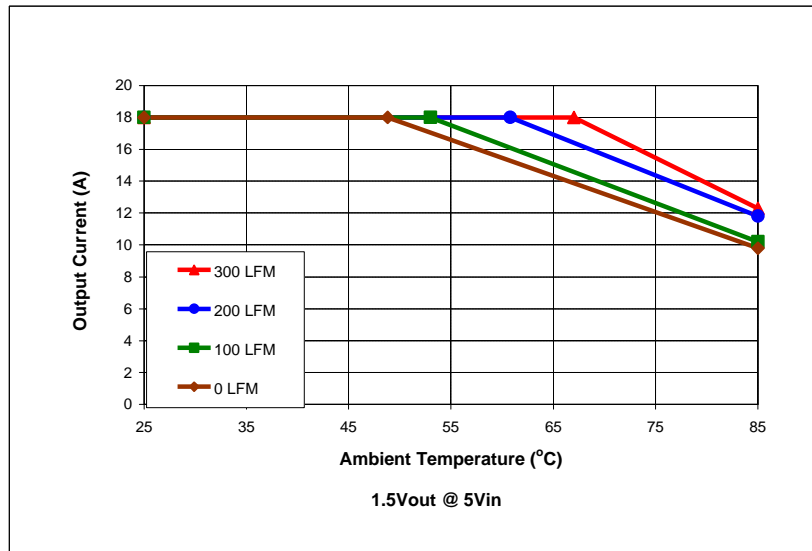

Model: APA18T04 Series

Date: Aug 2005

SH 14 OF 26



Technical Reference Note APA18T04 DC - DC Series

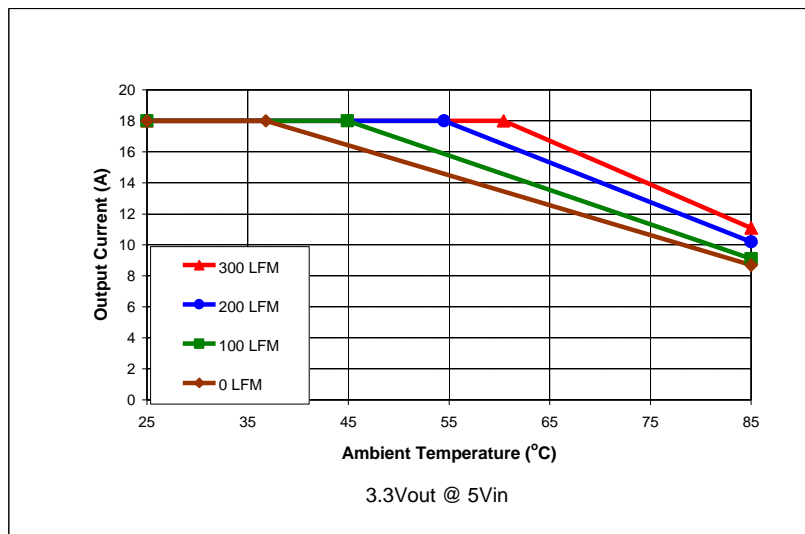
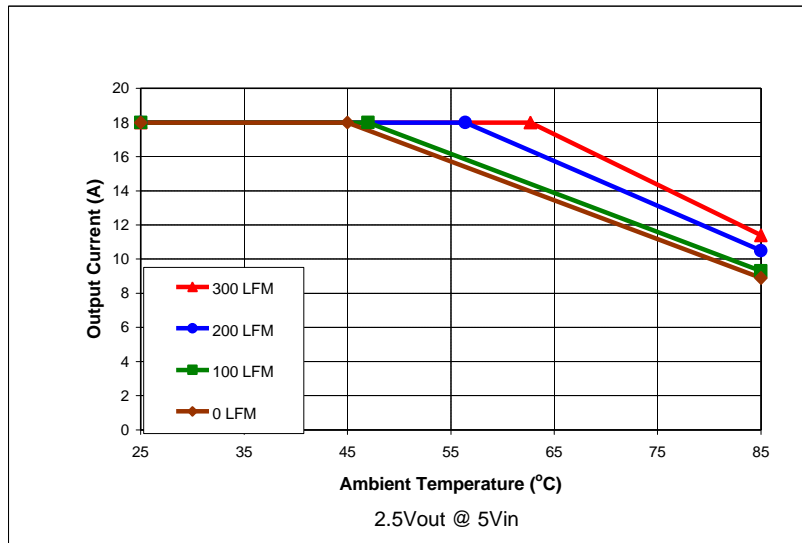

Model: APA18T04 Series

Date: Aug 2005

SH 15 OF 26

APPENDIX C: MODULE PIN ASSIGNMENT

PIN #	DESIGNATION	PIN #	DESIGNATION
+V _{IN}	+ Input Voltage	V _O	+Output
Enable	ON/OFF	Trim	V _O Adjust
GND	Return for V _{IN} and V _O		
Sense	+Output Sense pin		

Note: The pinout assignment of APA18T04-9 and APA18T04-9H are the same.

APPENDIX D: MECHANICAL OUTLINE/DRAWING (for reference only)

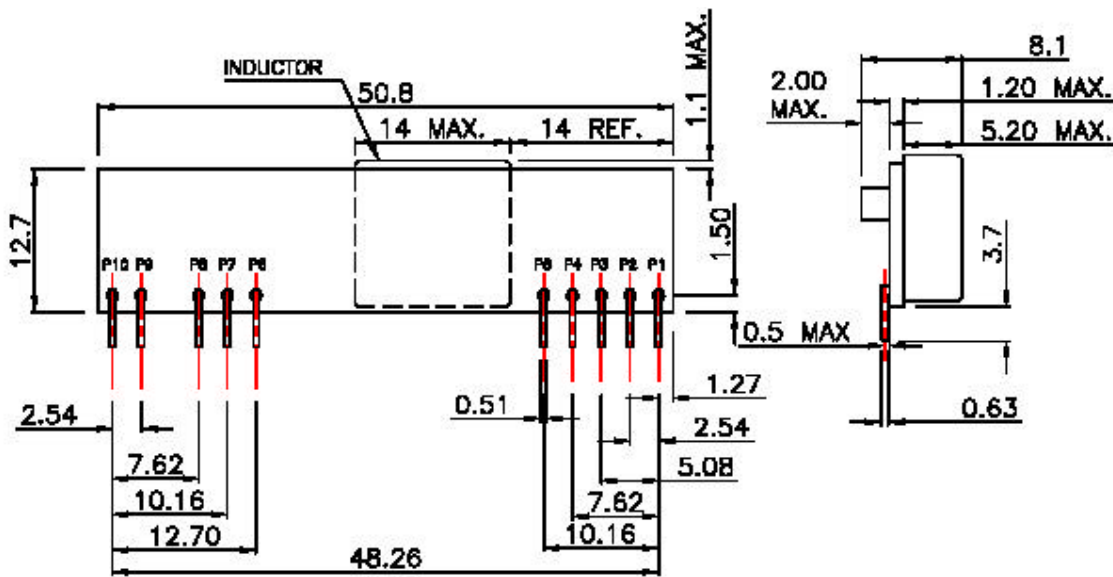

Figure 14. APA18 Mechanical Outline/ Drawing for Vertical type

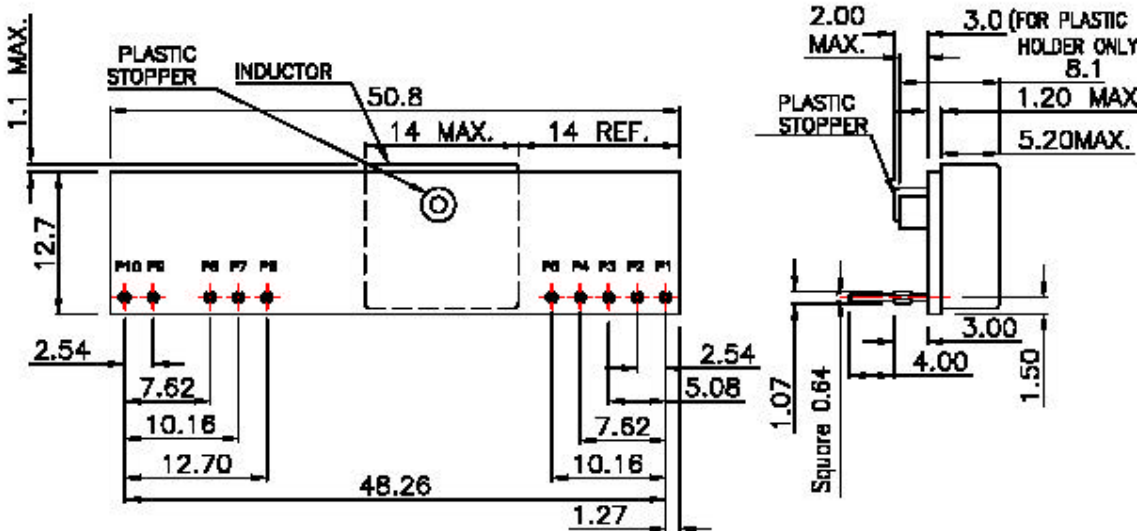

Figure 15. APA18 Mechanical Outline/ Drawing for Horizontal type

Pin Number	Pin Connection	Function
P1	Vo	Output Voltage
P2	Vo	Output Voltage
P3	SENSE	Sense
P4	Vo	Output Voltage
P5	GND	Ground
P6	GND	Ground
P7	Vin	Input Voltage
P8	Vin	Input Voltage
P9	TRIM	Output Voltage Adjustment
P10	ENABLE	Output Voltage Enable