



EP5368QI

600mA Synchronous Buck Regulator
With Integrated Inductor
3mm x 3mm x 1.1mm Package

April 2008

RoHS Compliant
Halogen Free

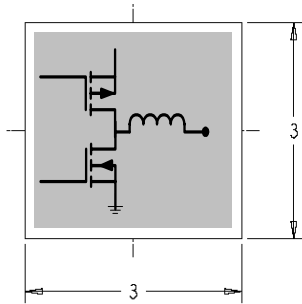

Featuring Integrated Inductor Technology

Product Overview

The EP5368QI is a synchronous buck converter with integrated Inductor, PWM controller, MOSFETS, and Compensation providing the smallest possible solution size. The EP5368QI requires only two small MLCC capacitors to make a complete solution. Integration of the inductor greatly simplifies design, contains noise, reduces part count, and reduces solution footprint. Low output ripple ensures compatibility with RF systems.

The EP5368QI operates at a switching frequency of 4 MHz, enabling this unprecedented level of integration and small external components. Type III voltage mode control is used to provide high noise immunity and wide control loop bandwidth. The device is stable over all input and output voltages. It can source 600mA of current over the industrial temperature range and up to 700mA over the commercial temperature range.

The small footprint makes this part ideal for space constrained portable applications. Shutdown current of <1uA extends battery life. Output voltage level is programmed via a 3-pin VID selector providing seven pre-programmed output voltages along with an option for external resistor divider.

Product Highlights

- **Integrated Inductor**
- **3mm x 3mm x 1.1mm QFN package**
- **Only two low cost MLCC caps required**
- **4 MHz switching frequency**
- High efficiency, up to 94%
- Up to 700mA continuous output current
- Wide 2.4V to 5.5V input range
- V_{OUT} Range 0.603V to $V_{IN} - 0.4V$
- 100% duty cycle capable
- Less than 1 μA standby current
- Low V_{OUT} ripple for RF compatibility
- Short circuit and over current protection
- UVLO and thermal protection
- Stable over entire operating range
- RoHS compliant; MSL 3 260°C reflow

Typical Application Circuit

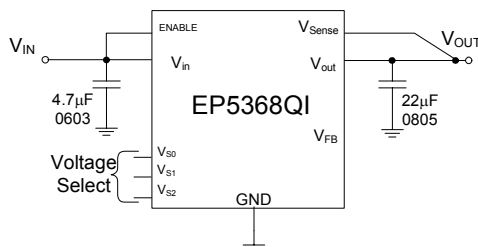

Figure 1. Typical application circuit.

Applications

- Noise sensitive RF applications
- Area constrained applications
- Smart phones and PDAs
- Portable gaming devices
- Personal Media Players
- Advanced Mobile Processors, DSP, IO, Memory, Video, Multimedia Engines

Pin Description

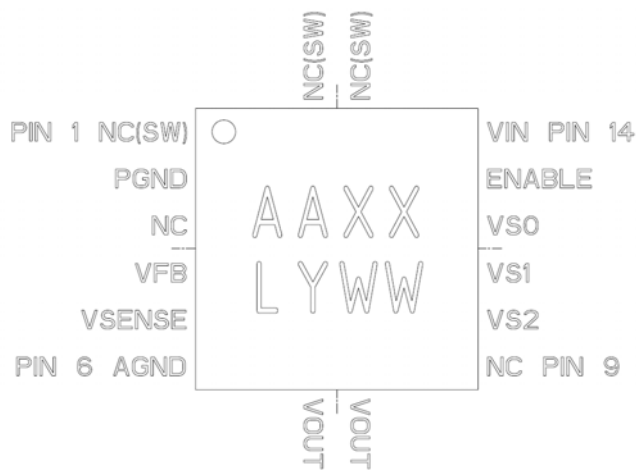

Figure 2. EP5368QI Package Pin-out.

NC (Pins 1,3,9,15,16): These pins should not be electrically connected to each other or to any external signal, voltage, or ground. One or more of these pins may be connected internally.

PGND: (Pin 2): Power ground.

V_{FB} (Pin 4): Feed back pin for external divider option. When using the external divider option ($VS_0=VS_1=VS_2=$ high) connect this pin to the center of the external divider. Set the divider such that $V_{FB} = 0.6V$. The “ground” side of the external divider should be connected to AGND.

V_{SENSE} (Pin 5): Sense pin for preset output voltages. When using preset voltages connect this to V_{LOAD} or as close to V_{LOAD} as possible to ensure the best regulation. When using external divider, connect this pin to V_{OUT} .

AGND: (Pin 6): Analog ground. This is the quiet ground for the internal control circuitry

V_{OUT} (Pin 7,8): Regulated output voltage.

VS₀, VS₁, VS₂ (Pin 10, 11, 12): Output voltage select. $VS_2=pin10$, $VS_1=pin11$, $VS_0=pin12$. Selects one of seven preset output voltages or choose external divider by connecting pins to logic high or low. Logic low is defined as $V_{LOW} \leq 0.4V$. Logic high is defined as $V_{HIGH} \geq 1.4V$. Any level between these two values is indeterminate. (refer to section on output voltage select for more detail).

ENABLE (Pin 13): Output enable. Enable = logic high, disable = logic low. Logic low is defined as $V_{LOW} \leq 0.4V$. Logic high is defined as $V_{HIGH} \geq 1.4V$. Any level between these two values is indeterminate.

V_{IN} (Pin 14): Input voltage pin. Supplies power to the IC. V_{IN} can range from 2.4V to 5.5V.

Functional Block Diagram

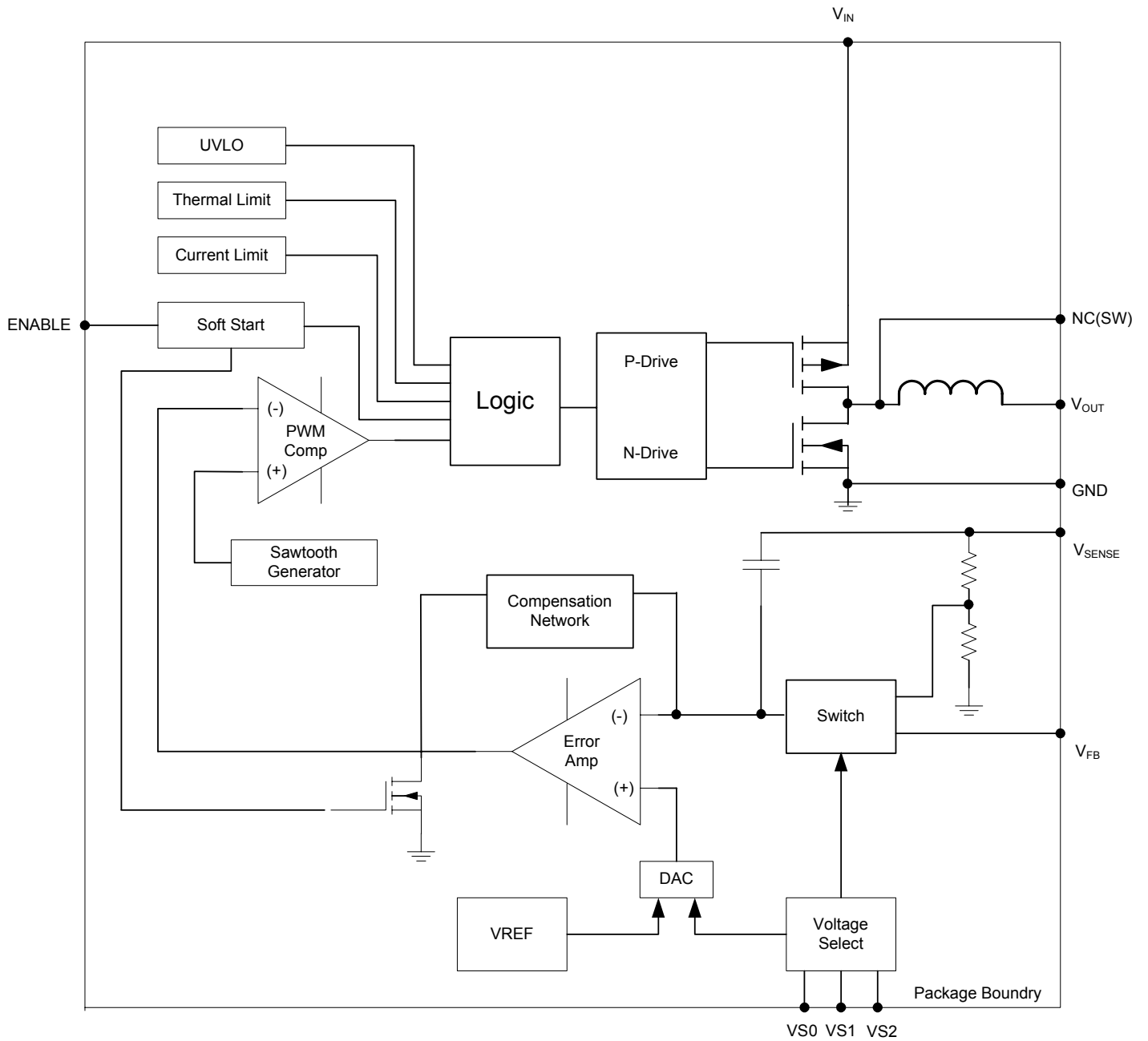

Figure 3. Functional block diagram.

Absolute Maximum Ratings

CAUTION: Absolute Maximum ratings are stress ratings only. Functional operation beyond recommended operating conditions is not implied. Stress beyond absolute maximum ratings may cause permanent damage to the device. Exposure to absolute maximum rated conditions for extended periods may affect device reliability.

PARAMETER	SYMBOL	MIN	MAX	UNITS
Input Supply Voltage	V_{IN}	-0.3	7.0	V
Voltages on: ENABLE, V_{SENSE} , V_{S0} - V_{S2}		-0.3	$V_{IN} + 0.3$	V
Voltage on: V_{FB}		-0.3	2.7	V
Storage Temperature Range	T_{STG}	-65	150	°C
Reflow Temp, 10 Sec, MSL3 JEDEC J-STD-020C			260	°C
ESD Rating (based on Human Body Model)			2000	V

Recommended Operating Conditions

PARAMETER	SYMBOL	MIN	MAX	UNITS
Input Voltage Range	V_{IN}	2.4	5.5	V
Operating Ambient Temperature	T_A	-40	+85	°C
Operating Junction Temperature	T_J	-40	+125	°C

Thermal Characteristics

PARAMETER	SYMBOL	TYP	UNITS
Thermal Resistance: Junction to Ambient (0 LFM)	θ_{JA}	100	°C/W
Thermal Overload Trip Point	T_{J-TP}	+150	°C
Thermal Overload Trip Point Hysteresis		15	°C

Electrical Characteristics

NOTE: $T_A = -40^\circ\text{C}$ to $+85^\circ\text{C}$ unless otherwise noted. Typical values are at $T_A = 25^\circ\text{C}$, $V_{IN} = 3.6\text{V}$.

$C_{IN} = 4.7\mu\text{F}$ 0603 MLCC, $C_{OUT} = 22\mu\text{F}$ 0805 MLCC.

PARAMETER	SYMBOL	TEST CONDITIONS	MIN	TYP	MAX	UNITS
Operating Input Voltage	V_{IN}		2.4		5.5	V
Output Voltage (presets) (VS pins must not be left floating)	V_o	<u>VS2 VS1 VS0</u>		V_{out}		V
		0 0 0		3.3		
		0 0 1		2.5		
		0 1 0		1.8		
		0 1 1		1.5		
		1 0 0		1.25		
		1 0 1		1.2		
		1 1 0		0.8		
	1 1 1		ext.			
Output Voltage (external divider)	V_o		0.6		$V_{IN}-0.4$	V
Dynamic Voltage Slew Rate	V_{slew}			1.5		mV/ μS
Continuous Output Current	I_{OUT}	$V_{IN} = 5\text{V}$, $0.603\text{V} < V_{OUT} < 3.3\text{V}$ $T_A = -40^\circ\text{C}$ to $+85^\circ\text{C}$	600			mA
Continuous Output Current	I_{OUT}	$V_{IN} = 5\text{V}$, $0.603\text{V} < V_{OUT} < 3.3\text{V}$ $T_A = -10^\circ\text{C}$ to $+85^\circ\text{C}$; (Application Circuit Figure 5.)	700			mA
Shut-Down Current	I_{SD}	Enable = Low		0.75		μA
PFET OCP Threshold	I_{LIM}	$2.4\text{V} \leq V_{IN} \leq 5.5\text{V}$, $0.6\text{V} \leq V_{IN} \leq 3.3\text{V}$	1.4	2		A

PARAMETER	SYMBOL	TEST CONDITIONS	MIN	TYP	MAX	UNITS
Feedback Pin Voltage	V_{FB}			0.603		V
Feedback Pin Input Current	I_{FB}				100	nA
VS0-VS1, Enable Voltage Threshold	V_{TH}	Pin = Low Pin = High	0.0 1.4		0.4 V_{IN}	
VS0-VS2 Pin Input Current	I_{VSX}			1		nA
Operating Frequency	F_{OSC}			4		MHz
PFET On Resistance	$R_{DS(ON)}$			340		$m\Omega$
NFET On Resistance	$R_{DS(ON)}$			270		$m\Omega$
V_{OUT} Accuracy	V_{OUT}	$T_A = 25^\circ C$ $2.4V \leq V_{IN} \leq 5.5V$ $-40^\circ C \leq T_A \leq +85^\circ C$ (all causes)	-2% -3%		+2% +3%	
Line Regulation		$2.4V \leq V_{IN} \leq 5.5V$		0.0566		%/V
Load Regulation		$0A \leq I_{LOAD} \leq 700mA$		0.0003		%/ mA
Soft-Start Operation						
Soft-Start Slew Rate	V_{SS}			1.5		$mV/\mu S$
Time to 90% V_{out}	T_{SS}	$V_{out} = 3.3V$		2.2		mS

Typical Performance Characteristics

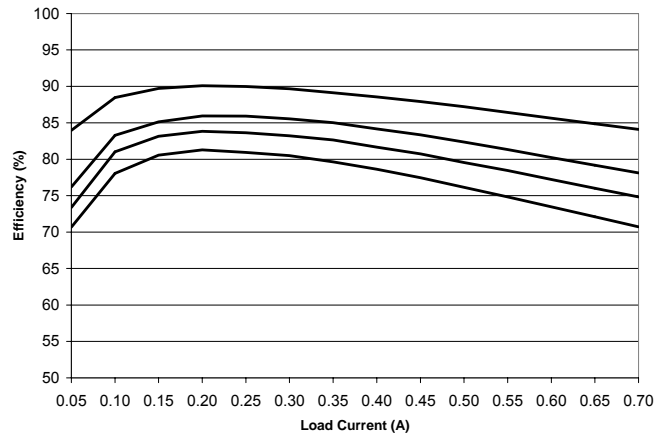
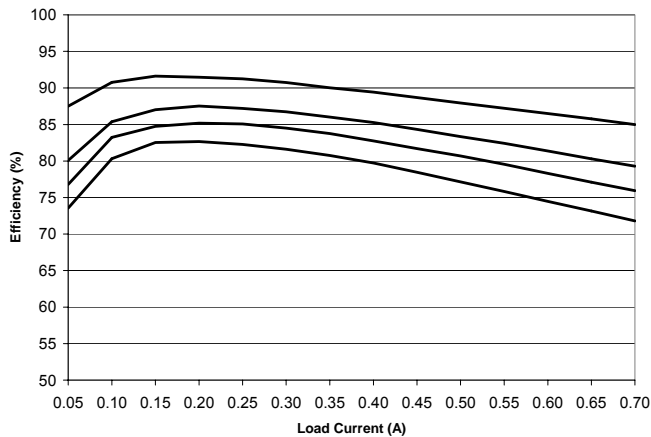

Efficiency, $V_{IN} = 3.3V$, $V_{OUT} = 1.2V, 1.5V, 1.8V, 2.5V$

Efficiency, $V_{IN} = 3.7V$, $V_{OUT} = 1.2V, 1.5V, 1.8V, 2.5V$

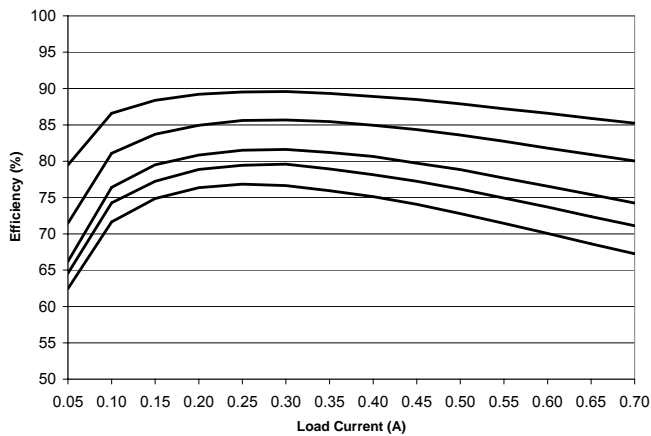

Efficiency, $V_{IN} = 5V$, $V_{OUT} = 1.2V, 1.5V, 1.8V, 2.5V, 3.3V$

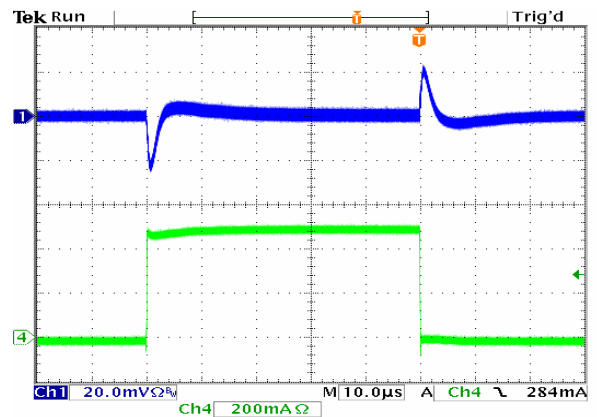

Transient, $V_{IN} = 3.6V$, $V_{OUT} = 1.2V$, Load = 0-500mA

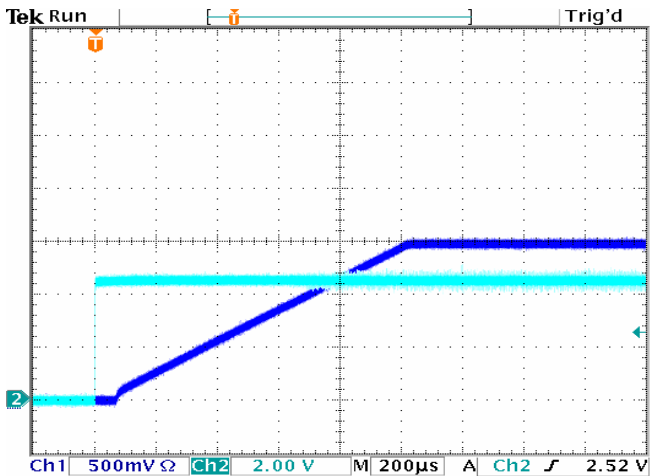

Startup, $V_{IN} = 3.6V$, $V_{OUT} = 1.5V$, Load = 500mA

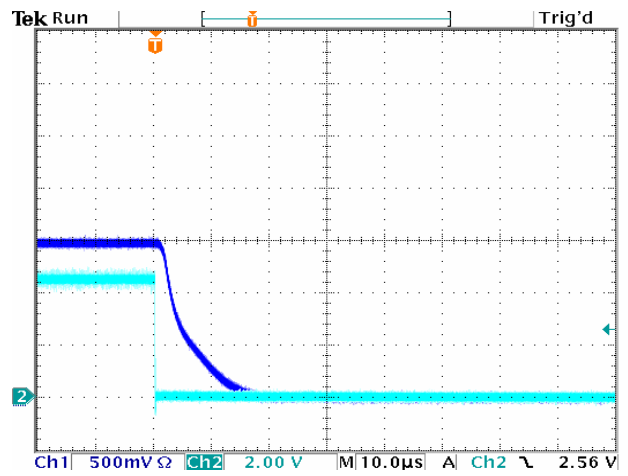

Shutdown, $V_{IN} = 3.6V$, $V_{OUT} = 1.5V$, Load = 500mA

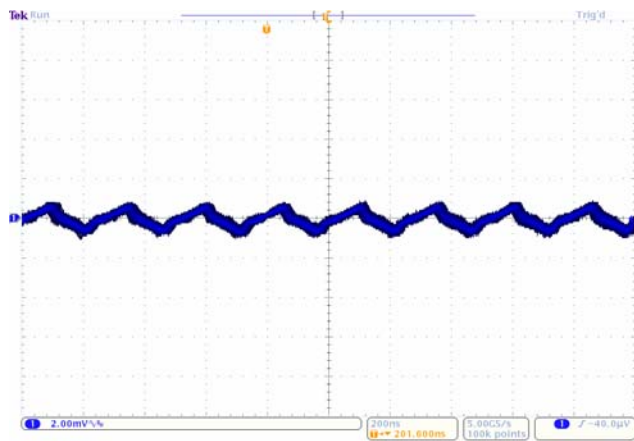

**Voltage Ripple, $V_{IN} = 3.3V$, $V_{OUT} = 1.8V$, Load = 0mA
 $C_{OUT} = 1x 22\mu F 0805$, 2.0mV/Div.**

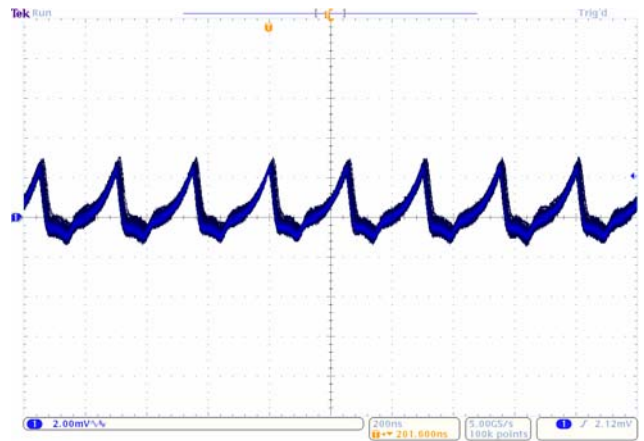

**Voltage Ripple, $V_{IN} = 3.3V$, $V_{OUT} = 1.8V$, Load = 600mA
 $C_{OUT} = 1x 22\mu F 0805$, 2.0mV/Div.**

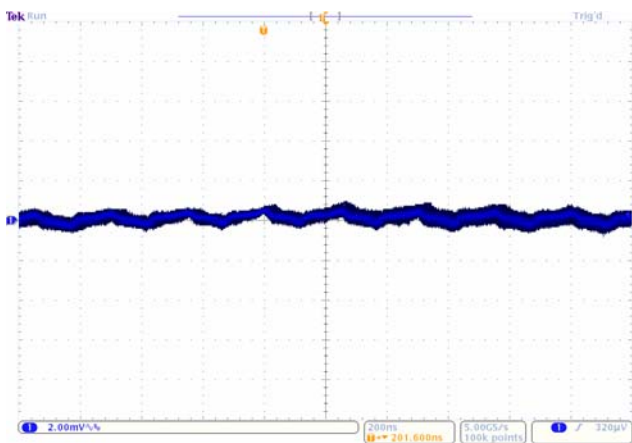

**Voltage Ripple, $V_{IN} = 3.3V$, $V_{OUT} = 1.8V$, Load = 0mA
 $C_{OUT} = 2x 10\mu F 0805$, 2.0mV/Div.**

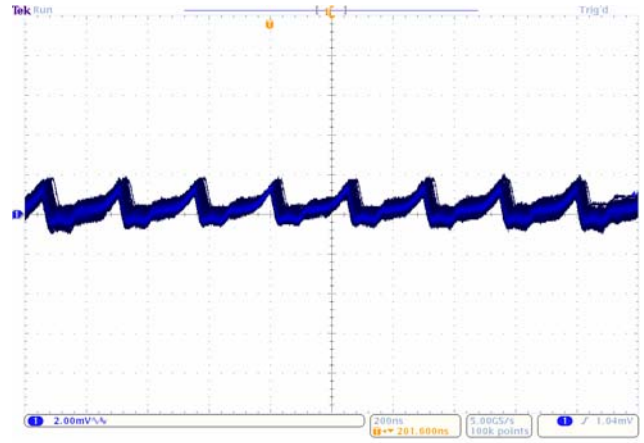

**Voltage Ripple, $V_{IN} = 3.3V$, $V_{OUT} = 1.8V$, Load = 600mA
 $C_{OUT} = 2x 10\mu F 0805$, 2.0mV/Div.**

Detailed Description

Functional Overview

The EP5368QI is a complete DCDC converter solution requiring only two low cost MLCC capacitors, MOSFET switches, PWM controller, Gate-drive, compensation, and inductor are integrated into the tiny 3mm x 3mm x 1.1mm package to provide the smallest footprint possible while maintaining high efficiency, low ripple, and high performance. The converter uses voltage mode control to provide the simplest implementation and high noise immunity. The device operates at a 4MHz switching frequency. The high switching frequency allows for a wide control loop bandwidth providing excellent transient performance. The high switching frequency further enables the use of very small components making possible this unprecedented level of integration.

Enpirion's proprietary power MOSFET technology provides very low switching loss at frequencies of 4 MHz and higher, allowing for the use of very small internal components, and high performance. Integration of the magnetics virtually eliminates the design/layout issues normally associated with switch-mode DCDC converters. All of this enables much easier and faster incorporation into various applications to meet demanding EMI requirements.

Output voltage is chosen from seven preset values via a three pin VID voltage select scheme. An external divider option enables the selection of any voltage in V_{IN} to 0.6V range. This reduces the number of components that must be qualified and reduces inventory burden. The VID pins can be toggled on the fly to implement glitch free dynamic voltage scaling.

Protection features include under-voltage lock-out (UVLO), over-current protection (OCP), short circuit protection, and thermal overload protection.

Integrated Inductor

Enpirion has introduced the world's first product family featuring integrated inductors. The EP5368QI utilizes a proprietary low loss integrated inductor. The use of an internal inductor localizes the noises associated with the output loop currents. The inherent shielding and compact construction of the integrated inductor reduces the radiated noise that couples into the traces of the circuit board. Further, the package layout is optimized to reduce the electrical path length for the AC ripple currents that are a major source of radiated emissions from DCDC converters. The integrated inductor significantly reduces parasitic effects that can harm loop stability, and makes layout very simple.

Stable Over Wide Range of Operating Conditions

The EP5368QI utilizes an internal type III compensation network and is designed to provide a high degree of stability over a wide range of operating conditions. The device operates over the entire input and output voltage range with no external modifications required. The very high switching frequency allows for a very wide control loop bandwidth.

Soft Start

Internal soft start circuits limit in-rush current when the device starts up from a power down condition or when the "ENABLE" pin is asserted "high". Digital control circuitry limits the V_{OUT} ramp rate to levels that are safe for the Power MOSFETS and the integrated inductor. The soft start ramp rate is nominally 1.5V/mS.

Over Current/Short Circuit Protection

The current limit function is achieved by sensing the current flowing through a sense P-MOSFET which is compared to a reference current. When this level is exceeded the P-FET is turned off and the N-FET is turned on, pulling V_{OUT} low. This condition is maintained for a period of 1mS and then a normal soft start is initiated. If the over current condition still persists, this cycle will repeat in a “hiccup” mode.

Under Voltage Lockout

During initial power up an under voltage lockout circuit will hold-off the switching circuitry until the input voltage reaches a sufficient level to insure proper operation. If the voltage drops below the UVLO threshold the lockout circuitry will again disable the switching. Hysteresis is included to prevent chattering between states.

Enable

The ENABLE pin provides a means to shut down the converter or enable normal operation. A logic low will disable the converter and cause it to shut down. A logic high will enable the converter into normal operation. In shutdown mode, the device quiescent current will be less than 1 μ A.

NOTE: This pin must not be left floating.

Thermal Shutdown

When excessive power is dissipated in the chip, the junction temperature rises. Once the junction temperature exceeds the thermal shutdown temperature the thermal shutdown circuit turns off the converter output voltage thus allowing the device to cool. When the junction temperature decreases by 15C°, the device will go through the normal startup process.

Application Information

Output Voltage Select

To provide the highest degree of flexibility in choosing output voltage, the EP5368QI uses a 3 pin VID, or Voltage ID, output voltage select arrangement. This allows the designer to choose one of seven preset voltages, or to use an external voltage divider. Internally, the output of the VID multiplexer sets the value for the voltage reference DAC, which in turn is connected to the non-inverting input of the error amplifier. This allows the use of a single feedback divider with constant loop gain and optimum compensation, independent of the output voltage selected.

Table 1 shows the various VS0-VS2 pin logic states and the associated output voltage levels. A logic “1” indicates a connection to V_{IN} or to a “high” logic voltage level. A logic “0” indicates a connection to ground or to a “low” logic voltage level. These pins can be either

hardwired to V_{IN} or GND or alternatively can be driven by standard logic levels. Logic low is defined as $V_{LOW} \leq 0.4V$. Logic high is defined as $V_{HIGH} \geq 1.4V$. Any level between these two values is indeterminate. These pins must not be left floating.

Table 1. VID voltage select settings.

VS2	VS1	VS0	V_{OUT}
0	0	0	3.3V
0	0	1	2.5V
0	1	0	1.8V
0	1	1	1.5V
1	0	0	1.25V
1	0	1	1.2V
1	1	0	0.8V
1	1	1	User Selectable

External Voltage Divider

As described above, the external voltage divider option is chosen by connecting the VS0, VS1, and VS2 pins to VIN or logic “high”. The EP5368QI uses a separate feedback pin, VFB, when using the external divider. VSENSE must be connected to VOUT as indicated in Figure 4.

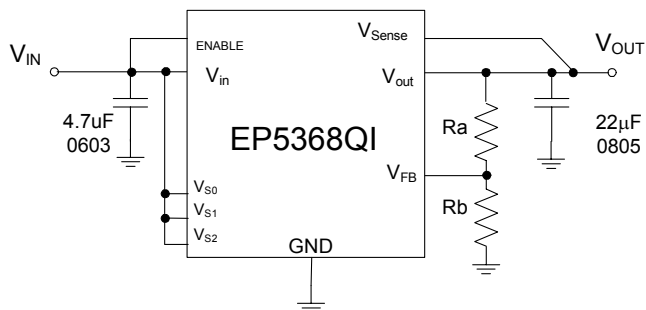

Figure 4. External Divider application circuit.

The output voltage is selected by the following formula:

$$V_{OUT} = 0.603V\left(1 + \frac{R_a}{R_b}\right)$$

R_a must be chosen as 200KΩ to maintain loop gain. Then R_b is given as:

$$R_b = \frac{1.206 \times 10^5}{V_{OUT} - 0.603} \Omega$$

V_{OUT} can be programmed over the range of 0.603V to V_{IN}-0.4V.

Dynamically Adjustable Output

The EP5368QI is designed to allow for dynamic switching between the predefined VID voltage levels. The inter-voltage slew rate is optimized to prevent excess undershoot or overshoot as the output voltage levels transition. The slew rate is identical to the soft-start slew rate of 1.5V/mS.

Dynamic transitioning between internal VID settings and the external divider is not allowed.

Input and Output Capacitors

The **input** capacitance requirement is 4.7uF 0603 MLCC. The input capacitor must be a X5R/X7R MLCC. Y5V or equivalent dielectric formulations lose capacitance with frequency, bias, and with temperature, and are not suitable for switch-mode DC-DC converter input filter applications.

The **output** capacitance requirement is approximately 20uF. Enpirion recommends a single 22uF 0805 MLCC. Ripple performance can be improved by using 2 x 10uF 0805 MLC capacitors.

The output capacitor must be a X5R/X7R or equivalent MLCC. Y5V or equivalent dielectric formulations lose capacitance with frequency, bias, and temperature and are not suitable for switch-mode DC-DC converter output filter applications.

Please consult Enpirion Applications Support for other capacitor case size combinations.

Operation at 700mA Output Current

Operation at 700mA is supported by using the application circuit shown in Figure 5. The modification in the compensation is to ensure stability over the entire set of input and output voltage conditions.

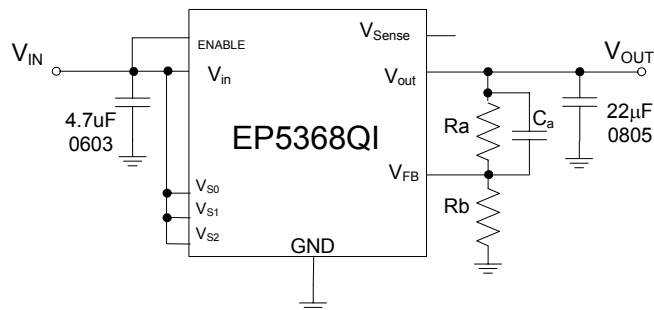

Figure 5. Applications circuit for operation at 700mA.

For 700mA operation, use the following component values:

$R_a = 249K\Omega$.

$C_a = 15pF$ 0402 MLCC capacitor.

Then R_b is given as:

$$R_b = \frac{1.501 \times 10^5}{V_{OUT} - 0.603} \Omega$$

V_{OUT} can be programmed over the range of 0.603V to $V_{IN}-0.4V$.

Stability cannot be assured if these guidelines are not followed.

Recommended PCB Footprint

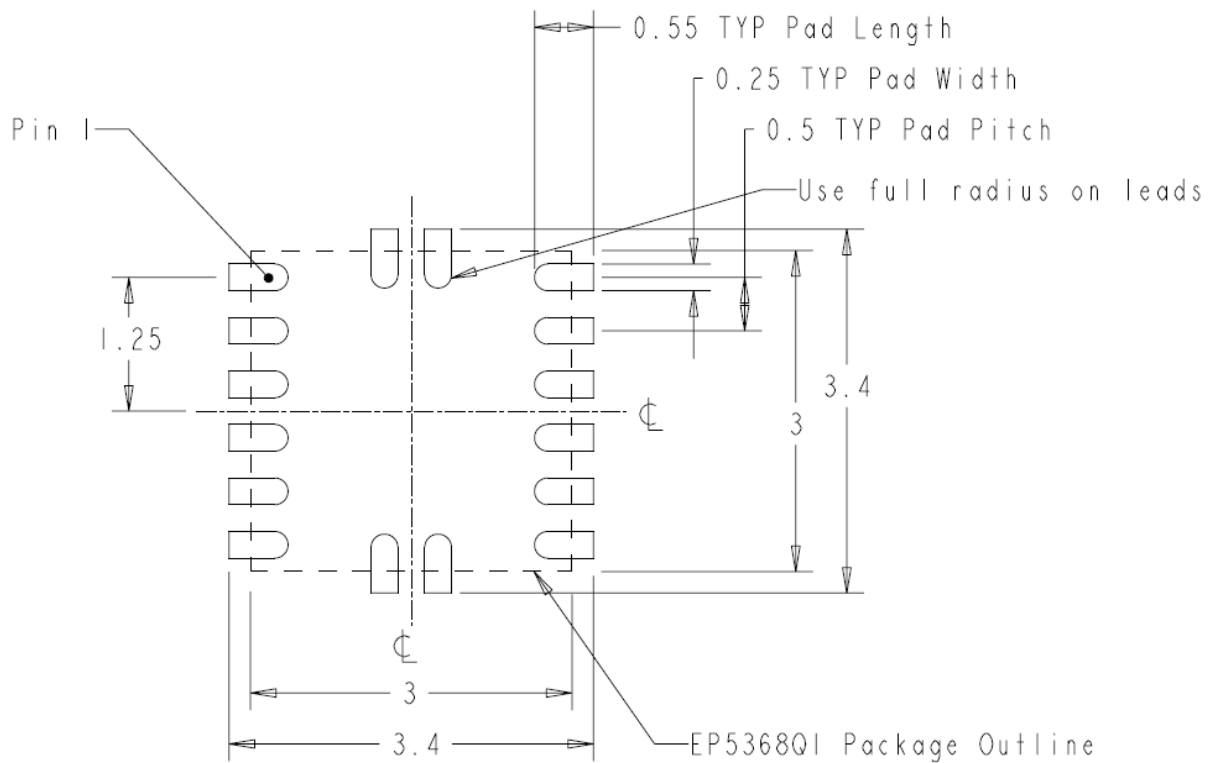

Dimensions in mm

Package Dimensions

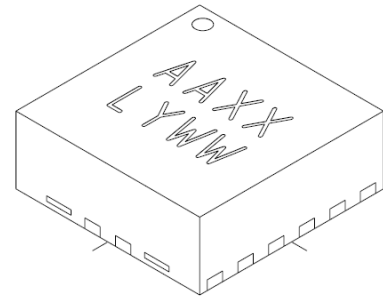
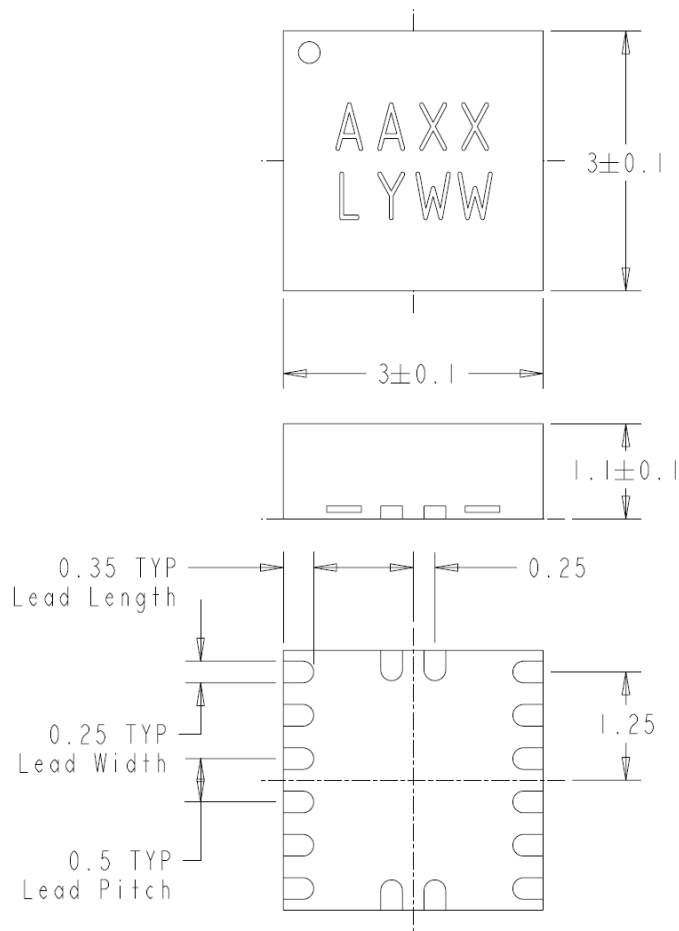

Dimensions in mm

Contact Information

Enpirion, Inc.
685 US Route 202/206 Suite 305
Bridgewater, NJ 08807
Phone: +1 908-575-7550
Fax: +1 908-575-0775

Enpirion reserves the right to make changes in circuit design and/or specifications at any time without notice. Information furnished by Enpirion is believed to be accurate and reliable. Enpirion assumes no responsibility for its use or for infringement of patents or other third party rights, which may result from its use. Enpirion products are not authorized for use in nuclear control systems, as critical components in life support systems or equipment used in hazardous environment without the express written authority from Enpirion.