

TC7MH139FK

Dual 2 - To - 4 Line Decoder

The TC7MH139 is an advanced high speed CMOS 2 to 4 LINE DECODER / DEMULTIPLEXER fabricated with silicon gate C²MOS technology.

It achieves the high speed operation similar to equivalent Bipolar Schottky TTL while maintaining the CMOS low power dissipation.

The active low enable input can be used for gating or it can be used as a data input for demultiplexing applications.

When the enable input is held High, all four outputs are fixed at a high logic level independent of the other inputs.

An input protection circuit ensures that 0 to 7V can be applied to the input pins without regard to the supply voltage. This device can be used to interface 5V to 3V systems and two supply systems such as battery back up. This circuit prevents device destruction due to mismatched supply and input voltages.

Features:

- High Speed..... $t_{pd} = 5.0ns$ (typ.) at $V_{CC} = 5V$
- Low Power Dissipation..... $I_{CC} = 4\mu A$ (max) at $T_a = 25^\circ C$
- High Noise Immunity..... $V_{NIH} = V_{NIL} = 28\% V_{CC}$ (min)
- Power Down Protection is provided on all inputs.
- Balanced Propagation Delays..... $t_{pLH} \approx t_{pHL}$
- Wide Operating Voltage Range..... V_{CC} (opr) = 2V~5.5V
- Pin and Function Compatible with 74ALS139

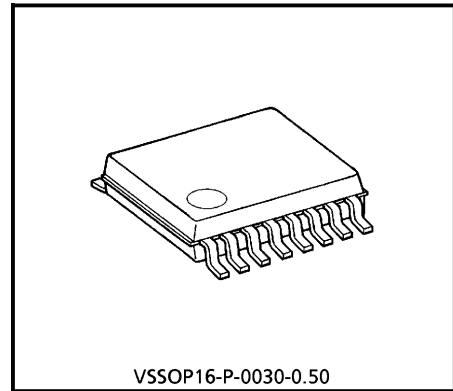

VSSOP16-P-0030-0.50

Weight: 0.02g (Typ.)

Pin Assignment

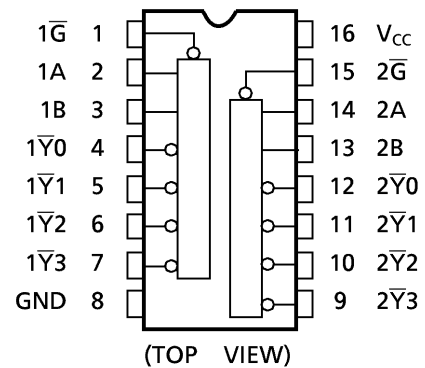

IEC Logic Symbol

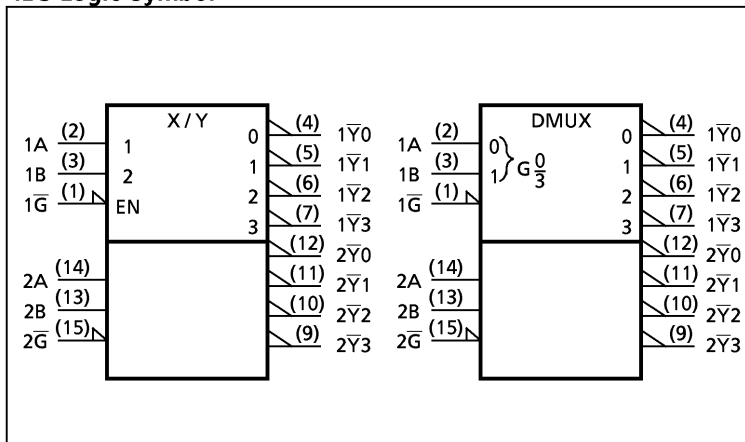

INPUTS		OUTPUTS				SELECTED OUTPUT
ENABLE	SELECT	$\bar{Y}0$	$\bar{Y}1$	$\bar{Y}2$	$\bar{Y}3$	
\bar{G}	B A	$\bar{Y}0$	$\bar{Y}1$	$\bar{Y}2$	$\bar{Y}3$	
H	X X	H	H	H	H	NONE
L	L L	L	H	H	H	$\bar{Y}0$
L	L H	H	L	H	H	$\bar{Y}1$
L	H L	H	H	L	H	$\bar{Y}2$
L	H H	H	H	H	L	$\bar{Y}3$

X: Don't Care

980910EBA2

● TOSHIBA is continually working to improve the quality and the reliability of its products. Nevertheless, semiconductor devices in general can malfunction or fail due to their inherent electrical sensitivity and vulnerability to physical stress. It is the responsibility of the buyer, when utilizing TOSHIBA products, to observe standards of safety, and to avoid situations in which a malfunction or failure of a TOSHIBA product could cause loss of human life, bodily injury or damage to property. In developing your designs, please ensure that TOSHIBA products are used within specified operating ranges as set forth in the most recent products specifications. Also, please keep in mind the precautions and conditions set forth in the TOSHIBA Semiconductor Reliability Handbook.

System Diagram

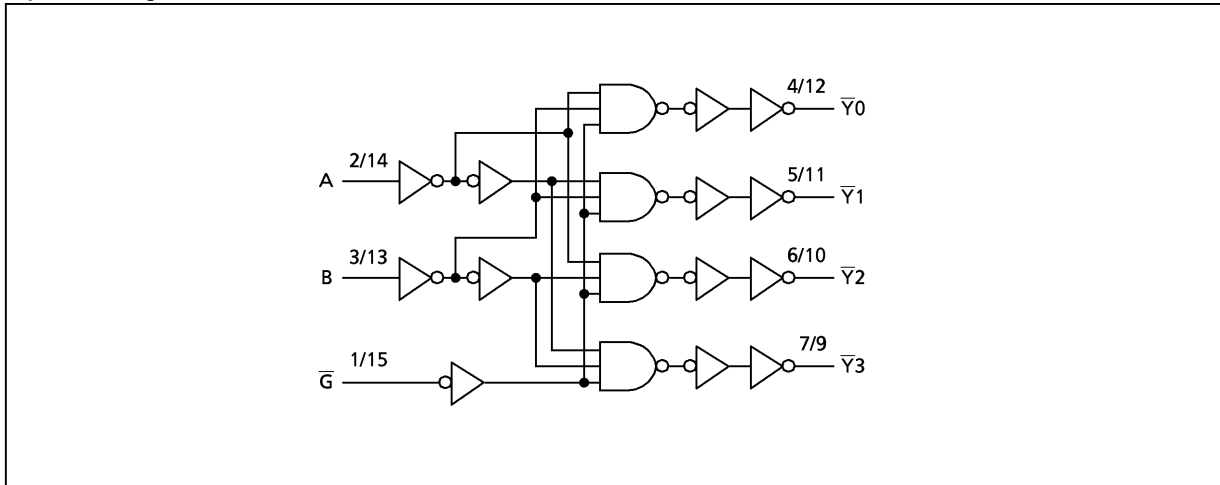

Absolute Maximum Ratings

PARAMETER	SYMBOL	VALUE	UNIT
Supply Voltage Range	V_{CC}	-0.5~7.0	V
DC Input Voltage	V_{IN}	-0.5~7.0	V
DC Output Voltage	V_{OUT}	-0.5~ $V_{CC} + 0.5$	V
Input Diode Current	I_{IK}	-20	mA
Output Diode Current	I_{OK}	±20	mA
DC Output Current	I_{OUT}	±25	mA
DC V_{CC} /Ground Current	I_{CC}	±75	mA
Power Dissipation	P_D	180	mW
Storage Temperature	T_{stg}	-65~150	°C

Recommended Operating Conditions

PARAMETER	SYMBOL	VALUE	UNIT
Supply Voltage	V_{CC}	2.0~5.5	V
Input Voltage	V_{IN}	0~5.5	V
Output Voltage	V_{OUT}	0~ V_{CC}	V
Operating Temperature	T_{opr}	-40~85	°C
Input Rise and Fall Time	dt / dv	0~100 ($V_{CC} = 3.3 \pm 0.3V$) 0~20 ($V_{CC} = 5 \pm 0.5V$)	ns / V

980910EBA2'

- The products described in this document are subject to the foreign exchange and foreign trade laws.
- The information contained herein is presented only as a guide for the applications of our products. No responsibility is assumed by TOSHIBA CORPORATION for any infringements of intellectual property or other rights of the third parties which may result from its use. No license is granted by implication or otherwise under any intellectual property or other rights of TOSHIBA CORPORATION or others.
- The information contained herein is subject to change without notice.

DC Electrical Characteristics

PARAMETER	SYMBOL	TEST CONDITION	V _{CC} (V)	Ta = 25°C			Ta = -40~85°C		UNIT	
				Min	Typ.	Max	Min	Max		
High - Level Input Voltage	V _{IH}		2.0 3.0~ 5.5	1.50 V _{CC} × 0.7	— —	— —	1.50 V _{CC} × 0.7	—	V	
Low - Level Input Voltage	V _{IL}		2.0 3.0~ 5.5	—	—	0.50 V _{CC} × 0.3	—	0.50 V _{CC} × 0.3	V	
High - Level Output Voltage	V _{OH}	V _{IN} = V _{IH} or V _{IL}	I _{OH} = -50μA	2.0	1.9	2.0	—	1.9	—	V
				3.0	2.9	3.0	—	2.9	—	
			I _{OH} = -4mA I _{OH} = -8mA	3.0	2.58	—	—	2.48	—	
				4.5	3.94	—	—	3.80	—	
Low - Level Output Voltage	V _{OL}	V _{IN} = V _{IH} or V _{IL}	I _{OL} = 50μA	2.0	—	0.0	0.1	—	0.1	V
				3.0	—	0.0	0.1	—	0.1	
				4.5	—	0.0	0.1	—	0.1	
				3.0	—	—	0.36	—	0.44	
				4.5	—	—	0.36	—	0.44	
Input Leakage Current	I _{IN}	V _{IN} = 5.5V or GND	0~5.5	—	—	±0.1	—	±1.0	μA	
Quiescent Supply Current	I _{CC}	V _{IN} = V _{CC} or GND	5.5	—	—	4.0	—	40.0		

AC Electrical Characteristics (Input t_r = t_f = 3ns)

PARAMETER	SYMBOL	TEST CONDITION	V _{CC} (V)	CL (pF)	Ta = 25°C			Ta = -40~85°C		UNIT
					Min	Typ.	Max	Min	Max	
Propagation Delay Time (A, B - \bar{Y})	t _{pLH} t _{pHL}		3.3 ± 0.3	15	—	7.2	11.0	1.0	13.0	ns
				50	—	9.7	14.5	1.0	16.5	
			5.0 ± 0.5	15	—	5.0	7.2	1.0	8.5	
				50	—	6.5	9.2	1.0	10.5	
Propagation Delay Time (\bar{G} - \bar{Y})	t _{pLH} t _{pHL}		3.3 ± 0.3	15	—	6.4	9.2	1.0	11.0	ns
				50	—	8.9	12.7	1.0	14.5	
			5.0 ± 0.5	15	—	4.4	6.3	1.0	7.5	
				50	—	5.9	8.3	1.0	9.5	
Input Capacitance	C _{IN}				—	4	10	—	10	pF
Power Dissipation Capacitance	C _{PD}	(Note 1)			—	26	—	—	—	

(Note 1): C_{PD} is defined as the value of the internal equivalent capacitance which is calculated from the operating current consumption without load.

Average operating current can be obtained by the equation:

$$I_{CC(opr.)} = C_{PD} \cdot V_{CC} \cdot f_{IN} + I_{CC} / 2 \text{ (per decoder)}$$

Input Equivalent Circuit

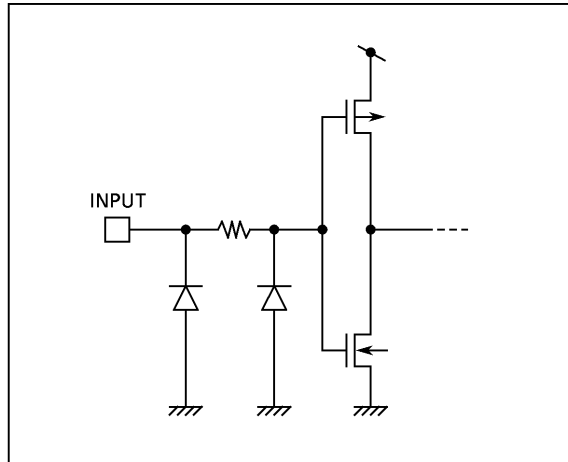

Outline Drawing

VSSOP16-P-0030-0.50

Unit: mm

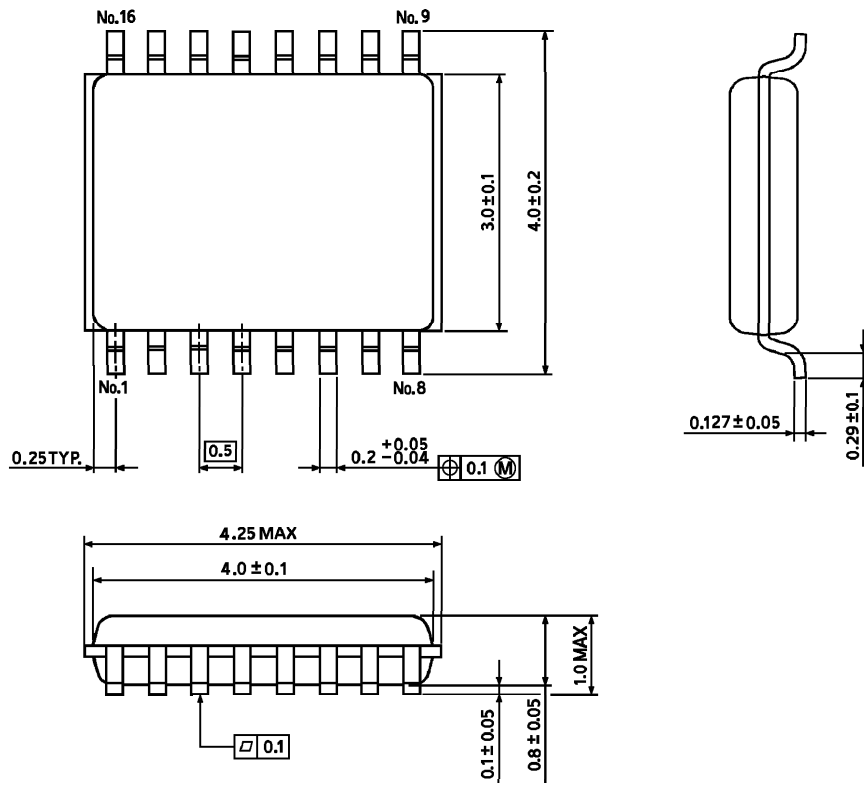

Weight: 0.02g (Typ.)