

USB Dual Downstream Port Filter with ESD Protection

Features

- Provides high performance EMI/RFI filtering
- Bi-directional ESD protection circuitry for optimum system protection
- Small package size
- USB 1.1 compliant

Applications

- Workstations, notebooks and desktop computers
- USB hubs
- Set-top boxes

Product Description

The USB is a four wire system utilizing a two wire twisted pair for transferring data, and two lines to supply power and ground connection to hubs and devices. The USB allows for two modes of signaling. The low speed mode is defined at 1.5Mb/s with the full speed at 12Mb/s.

The PACUSB200 provides ESD protection, EMI filtering and termination. It is ideal for protecting vulnerable components in the workstations, notebooks and desktop computers as well as in hubs. This device

supports two downstream ports. California Micro Devices also offers a complementary device to provide filtering and ESD protection for the upstream port. The PACUSB200 has the following characteristics:

- Compatible with Universal Serial Bus specification 1.1
- Capacity to protect both the system and device from external ESD pulses up to 6KV per the HBM
- Suppress EMI/RFI noise on high speed data lines

Pin Configuration

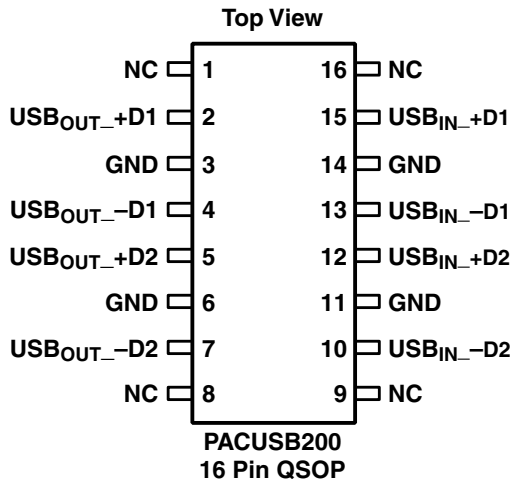

Schematic Configuration

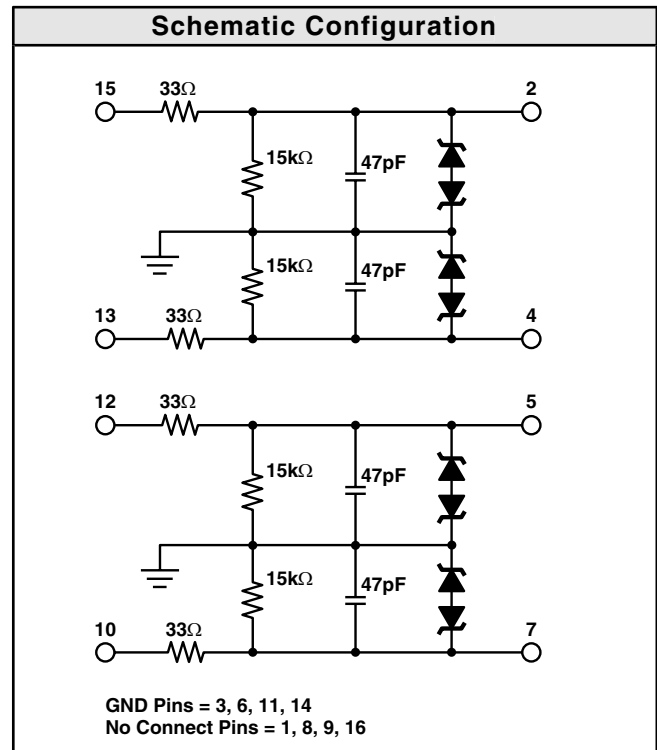

Standard Part Ordering Information

Package		Ordering Part Number		
Pins	Style	Tubes	Tape & Reel	Part Marking
16	QSOP	PACUSB200Q/T	PACUSB200Q/R	PACUSB200

Standard Specifications	
Absolute Tolerance (15K Ω Resistors)	$\pm 10\%$
Absolute Tolerance (33 Ω Resistors)	$\pm 5\%$
Absolute Tolerance (47pF Capacitors)	$\pm 20\%$
Operating Temperature Range	0 $^{\circ}$ C to 70 $^{\circ}$ C
ESD Protection (Human Body Model) MIL-STD-883, Method 3015 In System Protection (Note 1)	>4KV* >6KV*
Package	16 pin QSOP

*Guaranteed by design

Note 1: Pins 3, 6, 11, and 14 grounded
Pins 1, 8, 9, 10, 12, 13, 15, and 16 open
Contact discharge between pins
2, 4, 5, and 7 to ground, one at a time

Application Diagram

