



LinearDimensions
SEMICONDUCTOR

LND1083/84/85

7.5 A, 5 A, 3 A Low Dropout Positive Adjustable Regulators

GENERAL DESCRIPTION

The LND1083/LND1084/LND1085 series of positive adjustable regulators are designed to provide 7.5A, 5A and 3A with higher efficiency than currently available devices. All internal circuitry is designed to operate down to 1V input to output differential and the dropout voltage is fully specified as a function of load current. Dropout is guaranteed at a maximum of 1.5V at maximum output current. On-chip trimming adjusts the reference voltage to 1%. Current limit is also trimmed, minimizing the stress on both the regulator and power source circuitry under overload conditions.

The LND1083/LND1084/LND1085 devices are pin compatible with older 3 terminal regulators. A 10 μ F output capacitor is required on these new devices: however, this is usually included in most regulator designs.

FEATURES

- Three terminal Adjustable
- Output Current of 3A, 5A or 7.5A
- Operates Down to 1V dropout
- Guaranteed Dropout Voltage at Multiple Current Levels
- 0.015% Line regulation
- 0.01% Load Regulation
- 100% Thermal Limit Burn-In

TYPICAL APPLICATION DATA

5V, 5A Regulator

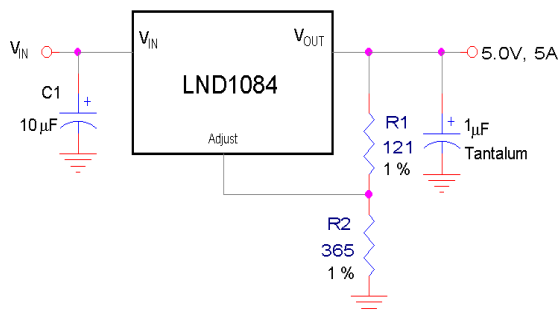

APPLICATIONS

- High Efficiency Linear Regulators
- Post Regulators for Switching Supplies
- Constant Current Regulators
- Battery Chargers



Package Information

T Package TO-220 Plastic Front View

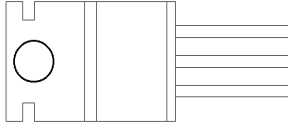

K Package TO-3 Metal Can Bottom View

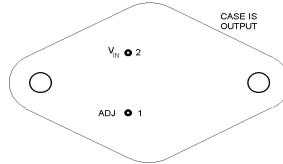

P Package TO-3P Plastic Front View

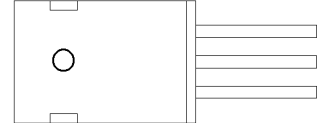

ABSOLUTE MAXIMUM RATING

SYMBOL	PARAMETER	MAXIMUM	UNITS
P_D	Power Dissipation	Internally Limited	W
V_{IN}	Input to Output Voltage Differential «M» grades «C»grades	35 30	V
T_J	Operating Junction Temperature Range «M»grades Control section Power Transistor «C»Grades Control Section Power Transistor	-55 to 150 -55 to 200 0 to 125 0 to 150	°C
T_{STG}	Storage Temperature	-65 to 150	°C
T_{LEAD}	Lead Temperature(soldering, 10 sec)	300	°C

DEVICE SELECTION GUIDE

DEVICE	OUTPUT CURRENT
LND1083	7.5A
LND1084	5.0A
LND1085	3.0A



ELECTRICAL CHARACTERISTICS

(See Note 1)

Parameter	Test conditions	Min	Typ	Max	Units
Reference Voltage	$I_{out}=10mA, T_J=25^{\circ}C$ $(V_{in}-V_{out})=3V(K \text{ Package Only})$ $10mA \leq I_{out} \leq I_{full \text{ load}}$ $1.5V \leq (V_{in}-V_{out}) \leq 25V(\text{Note 3})$	1.238	1.250	1.262	V
	*	1.225	1.250	1.270	
Line Regulation	$I_{load}=10mA, 1.5 \leq (V_{in}-V_{out}) \leq 15V,$ $T_J=25^{\circ}C$	*	0.015 0.035	0.2 0.2	%
	M grade $15V \leq (V_{in}-V_{out}) \leq 35V$	*	0.05	0.5	
	C grade $15V \leq (V_{in}-V_{out}) \leq 30V(\text{Notes 1,2})$	*	0.05	0.5	
Load Regulation	$(V_{in}-V_{out})=3V$ $10mA \leq I_{out} \leq I_{full \text{ load}}$ $T_J=25^{\circ}C(\text{notes 1,2,3,5})$	*	0.1 0.2	0.3 0.4	%
	Dropout Voltage	$\Delta V_{ref}=1\%, I_{out}=I_{full \text{ load}}$ (See Notes 4,5)	*	1.3	
Current Limit LND1083	$(V_{in}-V_{out})=5V$	*	8.0	9.5	A
	$(V_{in}-V_{out})=25V$	*	0.4	1.0	
LND1084	$(V_{in}-V_{out})=5V$	*	5.5	6.5	
	$(V_{in}-V_{out})=25V$	*	0.3	0.6	
LND1085	$(V_{in}-V_{out})=5V$	*	3.2	4.0	
	$(V_{in}-V_{out})=25V$	*	0.2	0.5	
Minimum Load Current	$(V_{in}-V_{out})=25V$	*	5	10	mA
Thermal regulation LND1083 LND1083 LND1085	$T_A=25^{\circ}C, 30ms \text{ pulse}$		0.002	0.01	%/ W
			0.003	0.015	
			0.004	0.02	
Ripple Rejection	$f=120Hz,$ $C_{adj}=25\mu F, C_{out}=25\mu F \text{ tantalum},$ $I_{out}=I_{full \text{ load}}, (V_{in}-V_{out})=3V(\text{Note 5})$	*	60	75	dB
Adjust Pin Current	$T_J=25^{\circ}C$	*	55	120	μA
Adjust Pin Current Change	$10mA \leq I_{out} \leq I_{full \text{ load}},$ $1.5V \leq (V_{in}-V_{out})=25V(\text{Note 5})$	*	0.2	5	
Temperature Stability		*	0.5		%
Long Term Stability	$T_A=125^{\circ}C, 1000Hrs$		0.3	1	
RMS output Noise(% of Vout)	$T_A=25^{\circ}C$ $10Hz \leq f \leq 10kHz$		0.003		



The * denotes the specifications which apply over the full operating temperature range.

Note 1: See thermal regulation specifications for changes in output voltage due to heating effects. Load and line regulations are measured at a constant junction temperature by low duty cycle pulse testing.

Note 2: Line and load regulation are guaranteed up to the maximum power dissipation (60W for the LND1083, 45W for the LND1084 (K, P) 30W for the LND1084 (T) and 30W for the LND1085). Power dissipation will not be available over the full input/output voltage range.

Note 3: $I_{filload}$ is defined in the current limit curves. $I_{filload}$ curve is defined as the minimum value of current limit as a function of input to output voltage.

Note 4: Dropout voltage is specified over the full output current range of the device.

Note 5: For LND1083 $I_{filload}$ is 5A for $-55^{\circ}\text{C} \leq T_j \leq -40^{\circ}\text{C}$ and 7.5A for $T_j > -40^{\circ}\text{C}$

BLOCK DIAGRAM

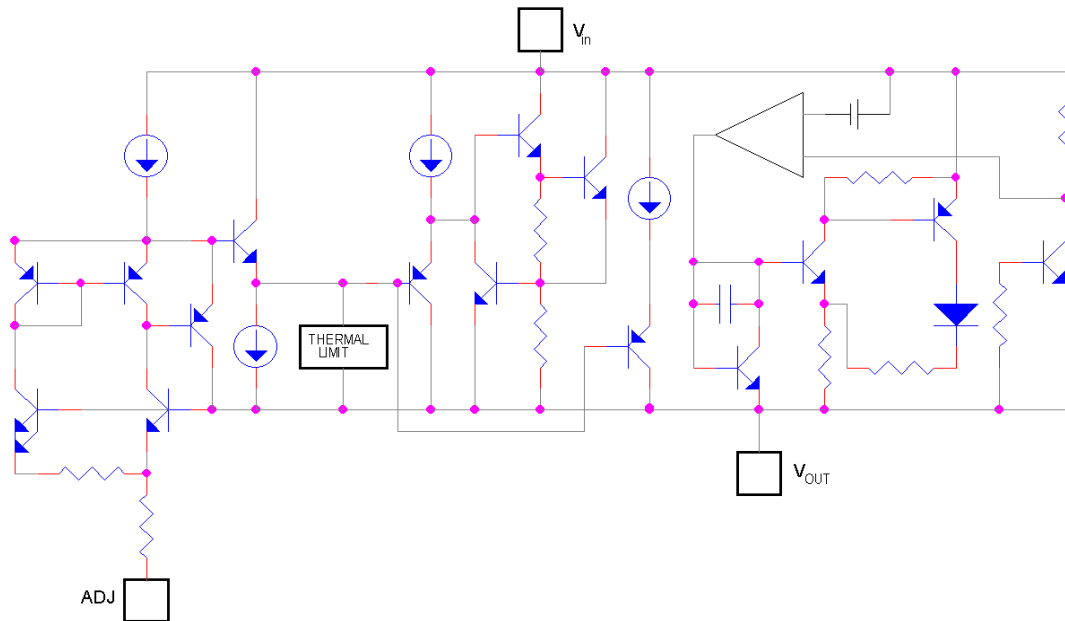



APPLICATIONS INFORMATION

The LND1083 family of three-terminal adjustable regulators is easy to use and has all the protection features that are expected in high performance voltage regulators.

Stability

The circuit design used in the LND1083 series requires the use of an output capacitor as part of the device frequency compensation. The addition of 150 μF aluminum electrolytic or a 22 μF solid tantalum on the output will ensure stability for all operating conditions.

Output Voltage

The LND1083 develops a 1.25V reference voltage between the Output pin and the Adjust pin (Figure 1). Placing a resistor between these two terminals causes a constant current to flow through R1 and down through R2 to set the output voltage. In general R1 is chosen so that this current is the specified minimum load current of 10mA. The current out of the Adjust pin is small as compared to the current from R1 and can be ignored.

Figure 1 Output Voltage

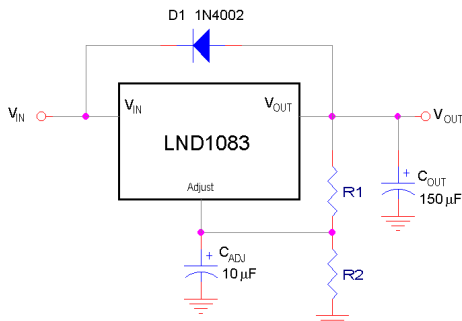

Protection Diodes

In normal operation LND1083 family does not need any protection diodes between the adjustment pin and the output and from the out to the input to prevent die overstresses. Internal resistors are limiting the internal current paths on the ADJ pin. Therefore even with bypass capacitors on the adjust pin no protection diode is needed to ensure device safety under short-circuit conditions.

Microsecond surge currents of 50A to 100A can be handled by the internal diode between the Output pin and the Input pin of the device. In normal operations it is difficult to get those values of surge currents even with the use of large output capacitance. Only with high value output capacitors, such as 1000 to 5000 μF and with the Input pin instantaneously shorted to ground, can damage occur. A diode from output to input is recommended (Figure 2).

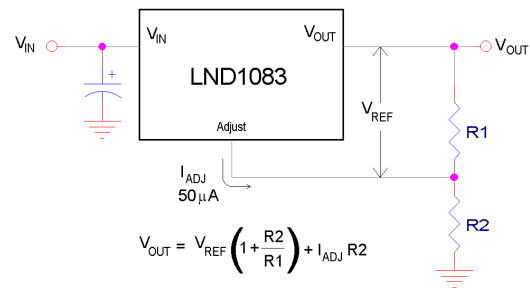

Figure 2. Protection Diodes.

Thermal Considerations

The LND1083 series have internal power and thermal-limiting circuitry designed to protect the device under overload conditions. However, maximum junction temperature ratings should not be exceeded under continuous normal load conditions. Careful consideration must be given to all sources of thermal resistance from junction to ambient, including junction-to-case, case to-heat sink interface and heat sink resistance itself.



TYPICAL APPLICATIONS

Improving ripple rejection

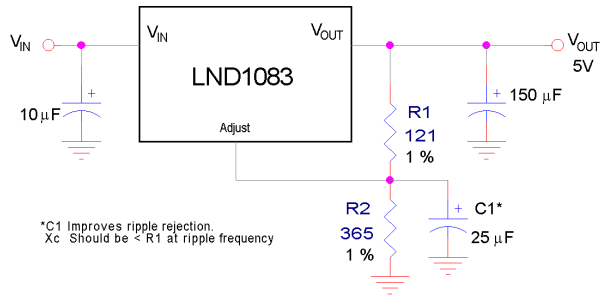

1.2V to 15V adjustable regulator

