

P-Channel 30-V (D-S) MOSFET with Schottky Diode

MOSFET PRODUCT SUMMARY		
V_{DS} (V)	$r_{DS(on)}$ (Ω)	I_D (A)
-30	0.020 @ $V_{GS} = -10$ V	8.3
	0.030 @ $V_{GS} = -4.5$ V	6.8

SCHOTTKY PRODUCT SUMMARY		
V_{KA} (V)	V_f (V) Diode Forward Voltage	I_F (A)
30	0.53 V @ 3 A	3

FEATURES

- TrenchFET® Power MOSFET
- LITTLE FOOT Plus™ Schottky

APPLICATIONS

- Battery Charging
- DC/DC Converters
 - Asynchronous Buck
 - Voltage Inverter

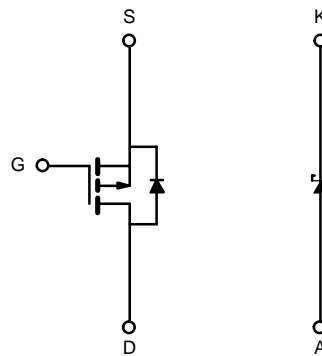
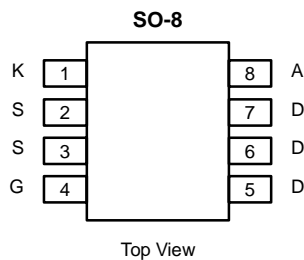

P-Channel MOSFET

ABSOLUTE MAXIMUM RATINGS ($T_A = 25^\circ\text{C}$ UNLESS OTHERWISE NOTED)					
Parameter		Symbol	10 Sec	Steady State	Unit
Drain-Source Voltage (MOSFET)		V_{DS}	-30		V
Reverse Voltage (Schottky)		V_{KA}	30		
Gate-Source Voltage (MOSFET)		V_{GS}	± 20		
Continuous Drain Current ($T_J = 150^\circ\text{C}$) (MOSFET) ^{a, b}	$T_A = 25^\circ\text{C}$	I_D	-8.3	-6.1	A
	$T_A = 70^\circ\text{C}$		-6.6	-4.9	
Pulsed Drain Current (MOSFET)		I_{DM}	-40		
Continuous Source Current (MOSFET Diode Conduction) ^{a, b}		I_S	-2.3	-1.25	
Average Forward Current (Schottky)		I_F	3		
Pulsed Forward Current (Schottky)		I_{FM}	20		
Maximum Power Dissipation (MOSFET) ^{a, b}	$T_A = 25^\circ\text{C}$	P_D	2.5	1.38	W
	$T_A = 70^\circ\text{C}$		1.6	0.88	
Maximum Power Dissipation (Schottky) ^{a, b}	$T_A = 25^\circ\text{C}$		1.5	1.0	
	$T_A = 70^\circ\text{C}$		0.98	0.64	
Operating Junction and Storage Temperature Range		T_J, T_{stg}	-55 to 150		$^\circ\text{C}$

Notes

- a. Surface Mounted on FR4 Board.
b. $t \leq 10$ sec.

THERMAL RESISTANCE RATINGS					
Parameter	Device	Symbol	Typical	Maximum	Unit
Maximum Junction-to-Ambient ($t \leq 10$ sec) ^a	MOSFET	R_{thJA}	37	50	°C/W
	Schottky		65	81	
Maximum Junction-to-Ambient ($t =$ steady state) ^a	MOSFET		70	90	
	Schottky		100	125	
Maximum Junction-to-Foot (Drain)	MOSFET	R_{thJF}	20	25	
	Schottky		50	62.5	

Notes

- a. Surface Mounted on FR4 Board.
b. $t \leq 10$ sec.

MOSFET SPECIFICATIONS ($T_J = 25^\circ\text{C}$ UNLESS OTHERWISE NOTED)						
Parameter	Symbol	Test Condition	Min	Typ	Max	Unit
Static						
Gate Threshold Voltage	$V_{GS(th)}$	$V_{DS} = V_{GS}, I_D = -250 \mu\text{A}$	-1.0			V
Gate-Body Leakage	I_{GSS}	$V_{DS} = 0 \text{ V}, V_{GS} = \pm 20 \text{ V}$			± 100	nA
Zero Gate Voltage Drain Current	I_{DSS}	$V_{DS} = -24 \text{ V}, V_{GS} = 0 \text{ V}$			-1	μA
		$V_{DS} = -24 \text{ V}, V_{GS} = 0 \text{ V}, T_J = 75^\circ\text{C}$			-10	
On-State Drain Current ^a	$I_{D(on)}$	$V_{DS} \geq -5 \text{ V}, V_{GS} = -10 \text{ V}$	-20			A
Drain-Source On-State Resistance ^a	$r_{DS(on)}$	$V_{GS} = -10 \text{ V}, I_D = -8.3 \text{ A}$		0.0165	0.020	Ω
		$V_{GS} = -4.5 \text{ V}, I_D = -6.8 \text{ A}$		0.0245	0.030	
Forward Transconductance ^a	g_{fs}	$V_{DS} = -15 \text{ V}, I_D = -8.3 \text{ A}$		22		S
Diode Forward Voltage ^a	V_{SD}	$I_S = -2.3 \text{ A}, V_{GS} = 0 \text{ V}$		-0.75	-1.1	V
Dynamic^b						
Total Gate Charge	Q_g	$V_{DS} = -15 \text{ V}, V_{GS} = -5 \text{ V}, I_D = -8.3 \text{ A}$		22	33	nC
Gate-Source Charge	Q_{gs}		9			
Gate-Drain Charge	Q_{gd}		6.6			
Gate-Resistance	R_G			1.9		Ω
Turn-On Delay Time	$t_{d(on)}$	$V_{DD} = -15 \text{ V}, R_L = 15 \Omega$ $I_D \cong -1 \text{ A}, V_{GEN} = -10 \text{ V}, R_G = 6 \Omega$		17	26	ns
Rise Time	t_r		15	23		
Turn-Off Delay Time	$t_{d(off)}$		56	85		
Fall Time	t_f		21	32		
Source-Drain Reverse Recovery Time	t_{rr}	$I_F = -2.3 \text{ A}, di/dt = 100 \text{ A}/\mu\text{s}$		45	70	

Notes

- a. Pulse test; pulse width $\leq 300 \mu\text{s}$, duty cycle $\leq 2\%$.
b. Guaranteed by design, not subject to production testing.

SCHOTTKY SPECIFICATIONS ($T_J = 25^\circ\text{C}$ UNLESS OTHERWISE NOTED)						
Parameter	Symbol	Test Condition	Min	Typ	Max	Unit
Forward Voltage Drop	V_F	$I_F = 3 \text{ A}$		0.485	0.53	V
		$I_F = 3 \text{ A}, T_J = 125^\circ\text{C}$		0.42	0.47	
Maximum Reverse Leakage Current	I_{rm}	$V_r = 30 \text{ V}$		0.008	0.1	mA
		$V_r = 30 \text{ V}, T_J = 75^\circ\text{C}$		0.4	5	
		$V_r = 30 \text{ V}, T_J = 125^\circ\text{C}$		6.5	20	
Junction Capacitance	C_T	$V_r = 15 \text{ V}$		102		pF



TYPICAL CHARACTERISTICS (25°C UNLESS NOTED) MOSFET

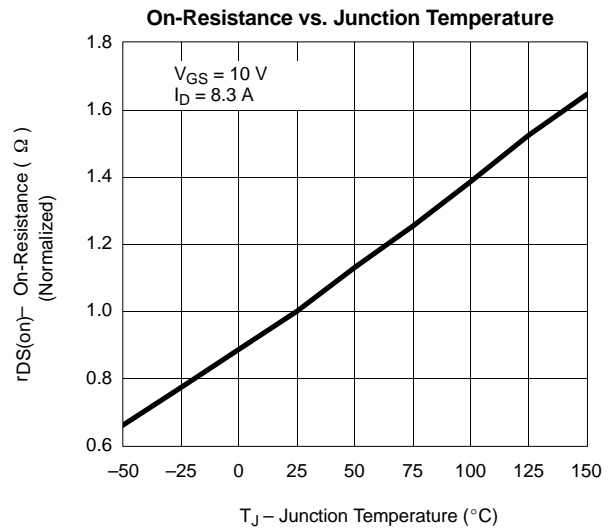
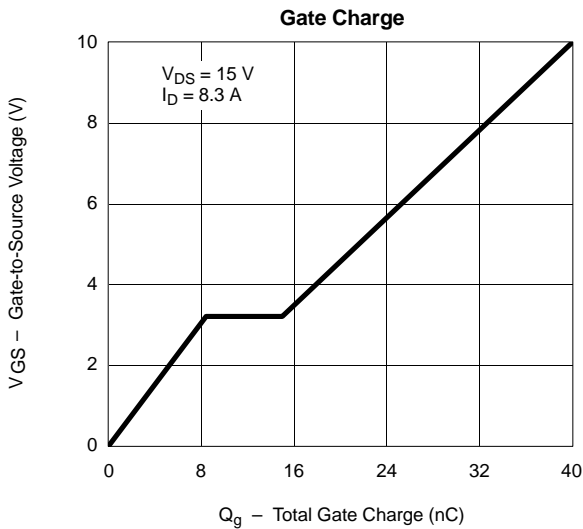
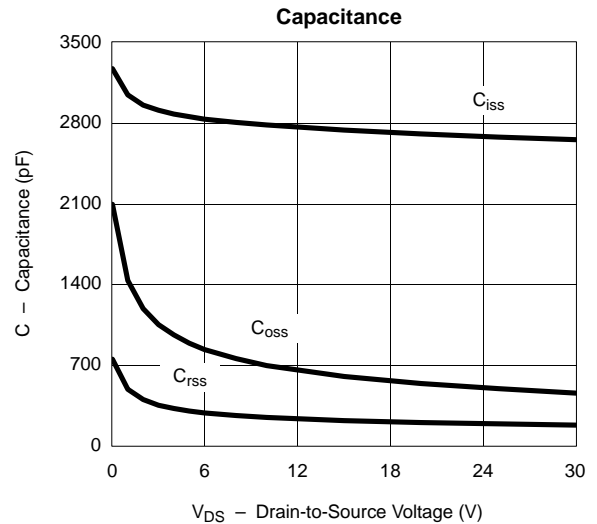
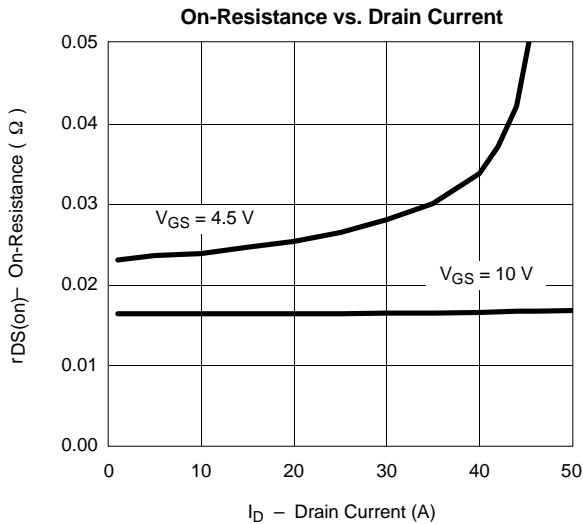
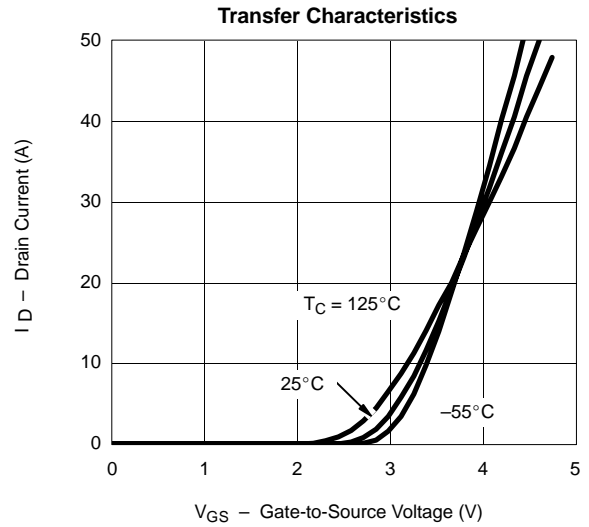
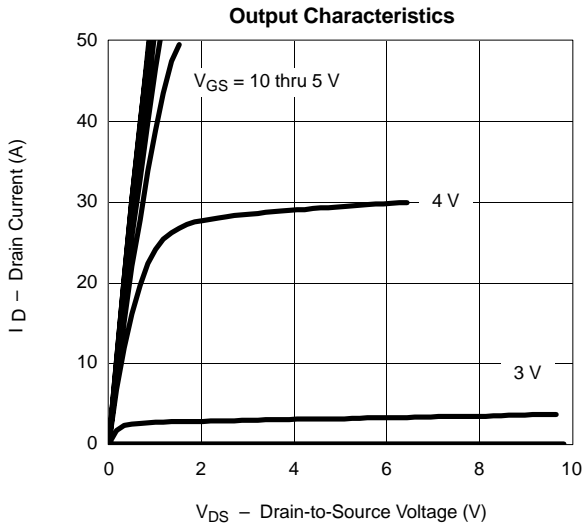

TYPICAL CHARACTERISTICS (25°C UNLESS NOTED)

MOSFET

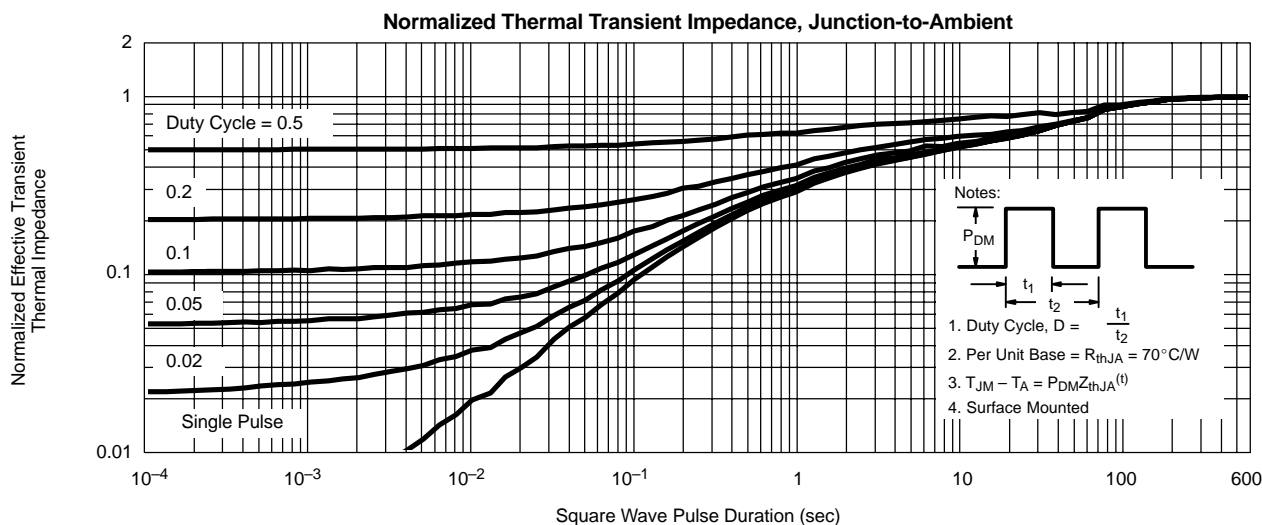
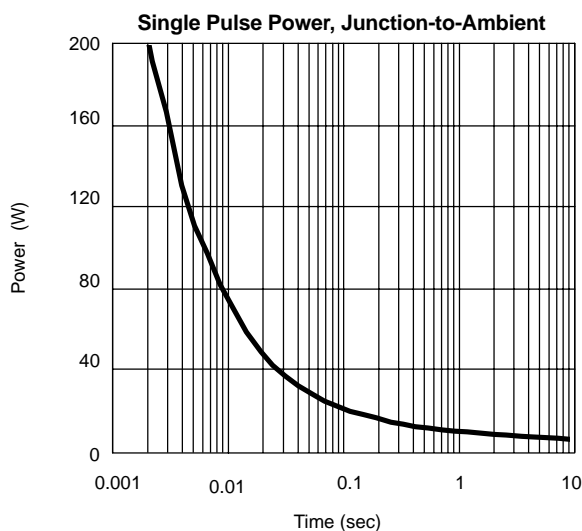
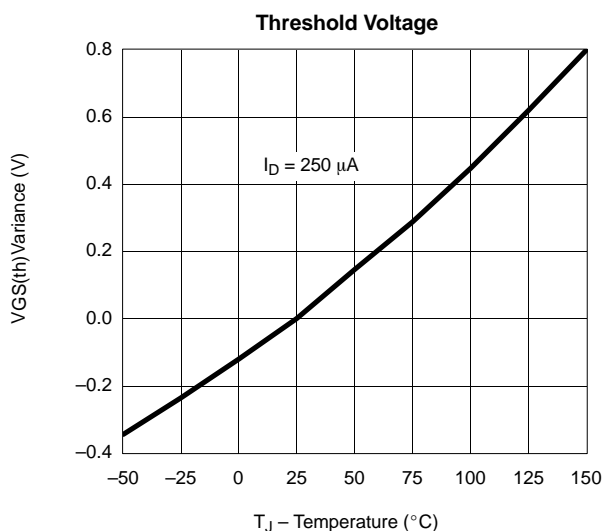
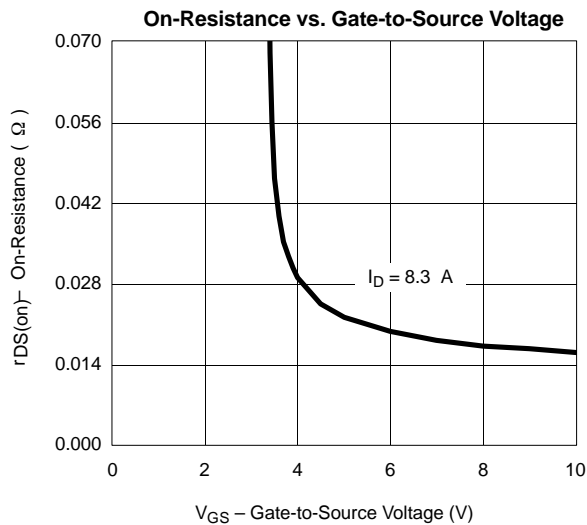
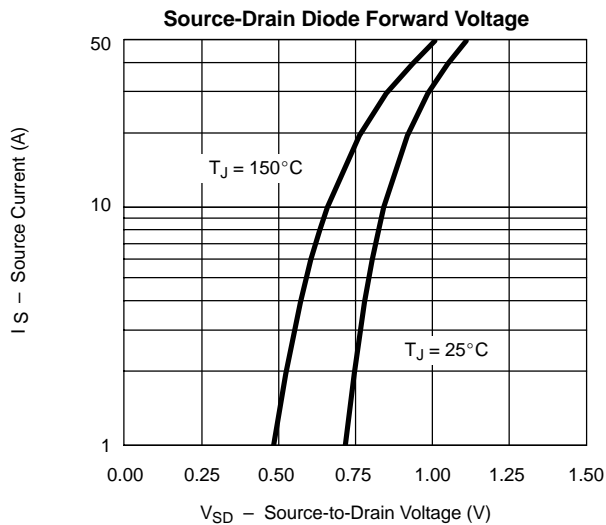



TYPICAL CHARACTERISTICS (25°C UNLESS NOTED) MOSFET

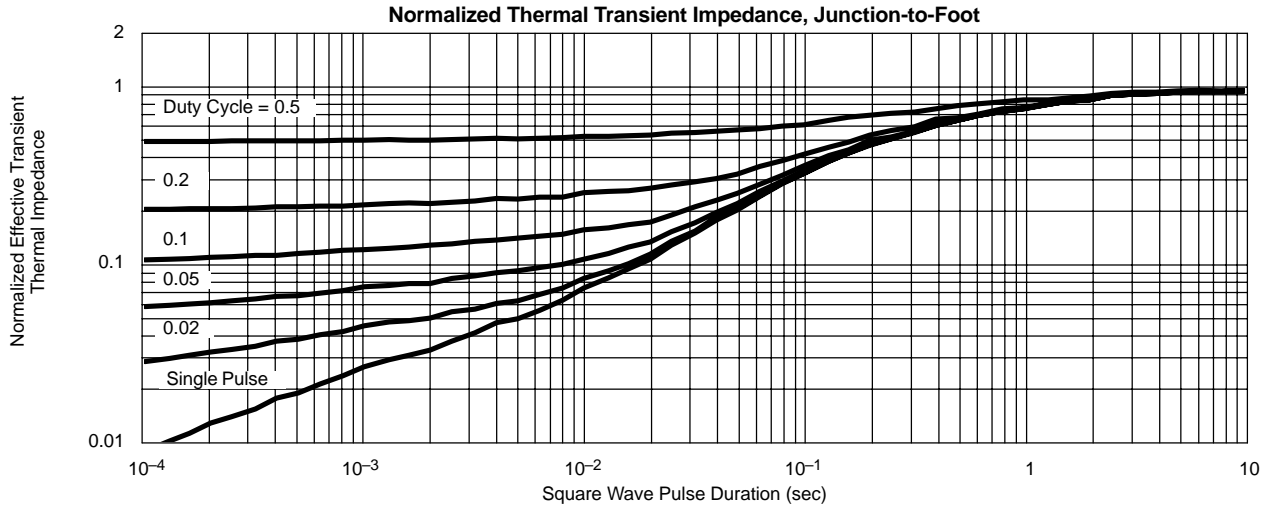

TYPICAL CHARACTERISTICS (25°C UNLESS NOTED) SCHOTTKY

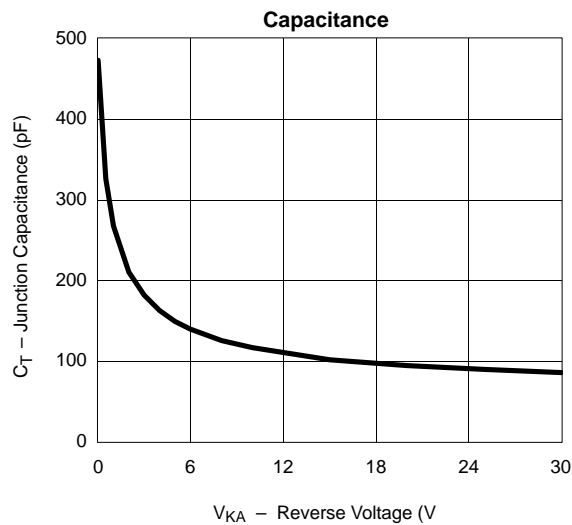
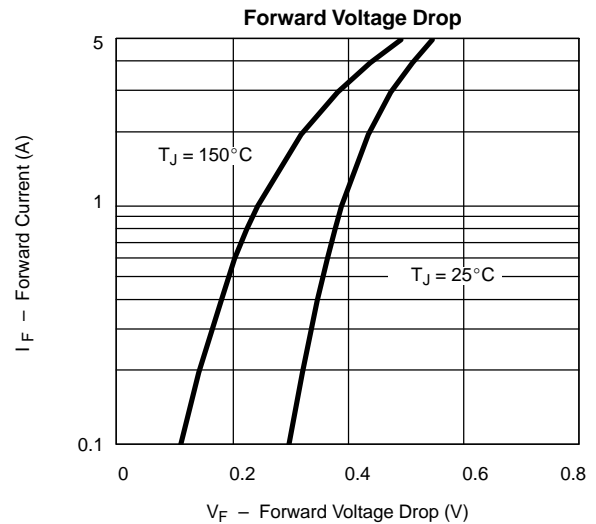
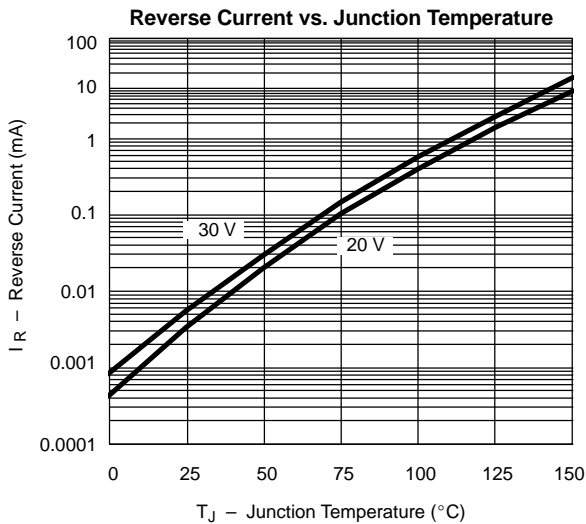

TYPICAL CHARACTERISTICS (25 °C UNLESS NOTED)

SCHOTTKY

