

SOT-89-3L Plastic-Encapsulate Transistors

2SC4373 TRANSISTOR (NPN)

FEATURES

- Small Flat Package
- Large Current Capacity

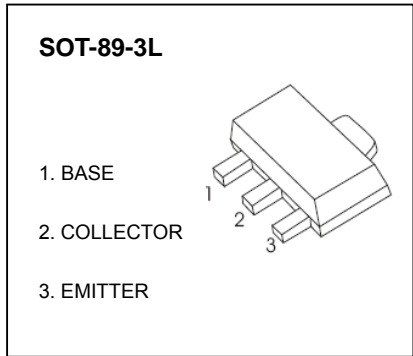

MAXIMUM RATINGS (T_a=25°C unless otherwise noted)

Symbol	Parameter	Value	Unit
V _{CB0}	Collector-Base Voltage	120	V
V _{CE0}	Collector-Emitter Voltage	120	V
V _{EBO}	Emitter-Base Voltage	5	V
I _C	Collector Current	800	mA
P _C	Collector Power Dissipation	500	mW
R _{θJA}	Thermal Resistance From Junction To Ambient	250	°C/W
T _j	Junction Temperature	150	°C
T _{stg}	Storage Temperature	-55~+150	°C

ELECTRICAL CHARACTERISTICS (T_a=25°C unless otherwise specified)

Parameter	Symbol	Test conditions	Min	Typ	Max	Unit
Collector-base breakdown voltage	V _{(BR)CBO}	I _C =1mA, I _E =0	120			V
Collector-emitter breakdown voltage	V _{(BR)CEO}	I _C =10mA, I _B =0	120			V
Emitter-base breakdown voltage	V _{(BR)EBO}	I _E =1mA, I _C =0	5			V
Collector cut-off current	I _{CB0}	V _{CB} =120V, I _E =0			0.1	μA
Emitter cut-off current	I _{EBO}	V _{EB} =5V, I _C =0			0.1	μA
DC current gain	h _{FE}	V _{CE} =5V, I _C =100mA	80		240	
Collector-emitter saturation voltage	V _{CE(sat)}	I _C =500mA, I _B =50mA			1	V
Base-emitter voltage	V _{BE}	V _{CE} =5V, I _C =500mA			1	V
Transition frequency	f _T	V _{CE} =5V, I _C =500mA		120		MHz
Collector output capacitance	C _{ob}	V _{CB} =10V, I _E =0, f=1MHz			30	pF

CLASSIFICATION OF h_{FE}

RANK	O	Y
RANGE	80 - 160	120 - 240
MARKING	CO	CY