

1-CHIP DEFLECTION SYSTEM

The KA2133 consists of a vertical system including an output function and a horizontal system including an AFC function. It is for use in small size color TVs, B/W TV receivers and monitors.

FUNCTIONS

(Horizontal Section)

- SYNC separators
- Horizontal oscillators
- Horizontal predrivers
- Horizontal predrivers
- Horizontal AFCs
- Shunt regulators (Typ.: 6.7V)

(Vertical Section)

- Vertical oscillators
- Vertical predrivers
- Vertical output
- Flyback generators

16 DIP H/S

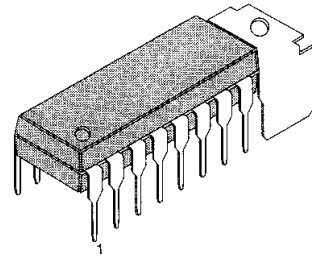

FEATURES

- Low power consumption, direct deflection coil driving capability (Flyback voltage two times as high as supply voltage is supplied during flyback period only)
- Variable circuit of vertical retrace time on chip.

ORDERING INFORMATION

| Device | Package | Operating Temperature |
|--------|------------|-----------------------|
| KA2133 | 16 DIP H/S | -20 ~ +75°C |

BLOCK DIAGRAM

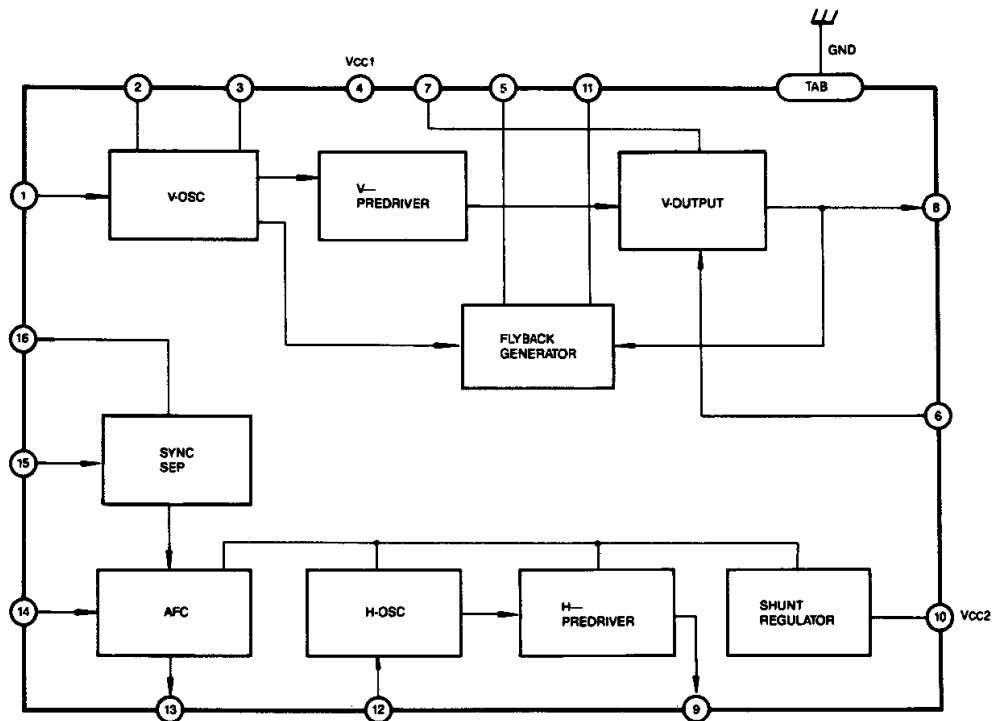

Fig. 1

ABSOLUTE MAXIMUM RATINGS ($T_a = 25^\circ\text{C}$)

| Characteristic | Symbol | Value | Unit |
|-----------------------------------|-----------|---------------|------------------|
| Vertical Supply Voltage | V_{CC} | 15 | V |
| Horizontal Supply Current | I_{10} | 30 | mA |
| Vertical Output Current | I_8 | - 500 ~ + 500 | mA peak |
| Horizontal Output Current (Pulse) | I_9 | 15 ~ + 5 | mA |
| Flyback Generator Output Current | I_5 | - 500 ~ + 500 | mA peak |
| Power Dissipation | P_D | 1.3 | W |
| Operating Temperature | T_{OPR} | - 20 ~ + 75 | $^\circ\text{C}$ |
| Storage Temperature | T_{STG} | - 40 ~ + 150 | $^\circ\text{C}$ |

RECOMMENDED OPERATING CONDITIONS ($T_a = 25^\circ\text{C}$)

| Characteristic | Symbol | Min | Typ | Max | Unit |
|---------------------------|----------|-----|------|------|------|
| Vertical Supply Voltage | V_{CC} | 9.6 | 12.0 | 14.4 | V |
| Horizontal Supply Current | I_{10} | 6.5 | 12 | 18 | mA |

ELECTRICAL CHARACTERISTICS ($V_{CC} = 12\text{V}$, $I_{10} = 12\text{mA}$, $T_a = 25^\circ\text{C}$)

| Characteristic | Symbol | Test Conditions | Min | Typ | Max | Unit | Test Fig |
|--|------------------------|--|------|-------|------|------------------|----------|
| Vertical Supply Current | $I_{CC} (1)$ | $SW_A = 2$ | — | 85 | 100 | mA | 2 |
| Vertical Supply Current | $I_{CC} (2)$ | No Input Signal $SW_A = 2$ | 6 | 12 | 20 | mA | 2 |
| Vertical Free Running Frequency | f_{VO} | $SW_A = 1$ | 55 | 60 | 65 | Hz | 2 |
| Drift of Vertical Free-Running Frequency | $\Delta f_{VO}/V_{CC}$ | $\Delta f_{VO} = 1f_{VO}(14.4\text{V}) - f_{VO}(9.6\text{V})$ $SW_A = 2$ | — | 0.8 | 2 | Hz | 2 |
| | $\Delta f_{VO}/T_A$ | $\Delta f_{VO} = 1f_{VO}(-20^\circ\text{C}) - f_{VO}(+70^\circ\text{C})$ $SW_A = 2$ | — | 1.5 | 2 | Hz | 2 |
| Vertical Output Center Voltage | V_{MID} | $SW_A = 2$ | 5.3 | 5.8 | 6.3 | V | 2 |
| Vertical Output Current | I_8 | $SW_A = 2$ | 450 | 500 | 550 | mA _{pp} | 2 |
| Horizontal Supply Pin Voltage | V_{10} | $SW_B = 2$ | 6.2 | 6.7 | 7.2 | V | 2 |
| Horizontal Free Running Frequency | f_{HO} | $I_{10} = 12\text{mA}$ $SW_B = 1$ | 15.0 | 15.75 | 16.5 | KHz | 2 |
| Horizontal Output Pulse Width | t_{HPW} | $f_{HO} = 15.75\text{KHz}$ $SW_B = 2$ | 23 | 25 | 27 | us | 2 |
| Horizontal Output Current | I_9 | $SW_B = 2$ | 0.8 | 1.3 | 2.0 | mA | 2 |

TEST CIRCUIT

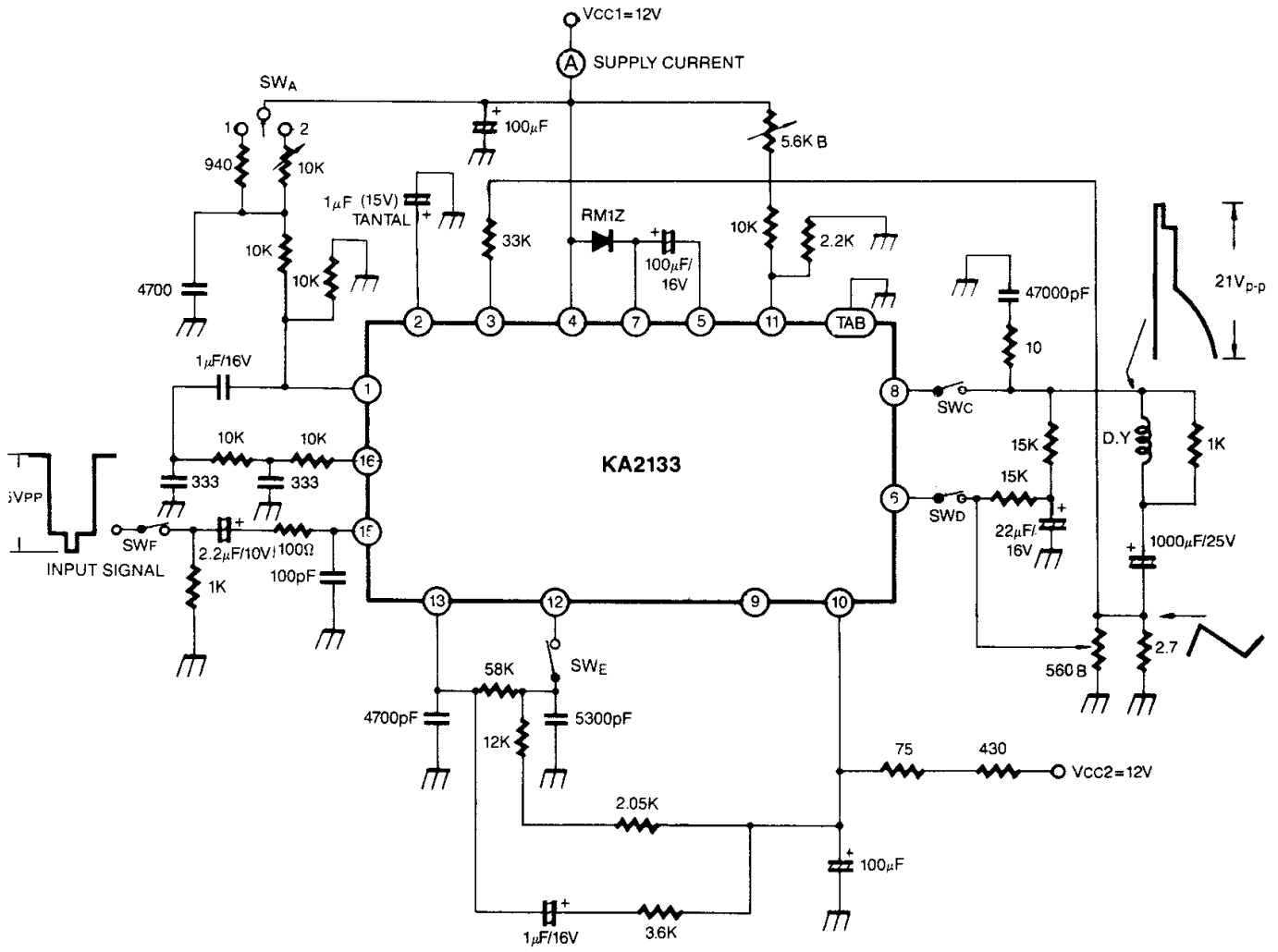

Fig. 2