

TV VERTICAL DEFLECTION SYSTEM

The KA2130A is a monolithic integrated circuit for use in the vertical deflection circuit of monochrome and small-sized color television receivers. It oscillates vertical signal synchronizing with the vertical synchronization signal and outputs the vertical deflection current with a single chip.

FUNCTIONS

- Vertical synchronization circuit.
- Vertical oscillation circuit.
- Vertical saw-tooth shaper.
- Vertical-output circuit.
- Clamping circuit for blanking pulse.
- Temperature compensating circuit.

FEATURES

- Less number of external components.
- Wide range of operational voltage (9V ~ 18 volts).
- Freely adjustable pull-in range.
- Adjustable blanking pulse-width.
- Large output current-capacity (2 A<sub>p.p.</sub>).
- Built-in adjusting circuit for flyback time.
- Easy mounting on printed circuit board.

10 SIP H/S

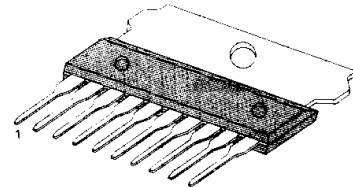

ORDERING INFORMATION

Device	Package	Operating Temperature
KA2130A	10 SIP H/S	-20 ~ +75°C

TYPICAL APPLICATION CIRCUIT

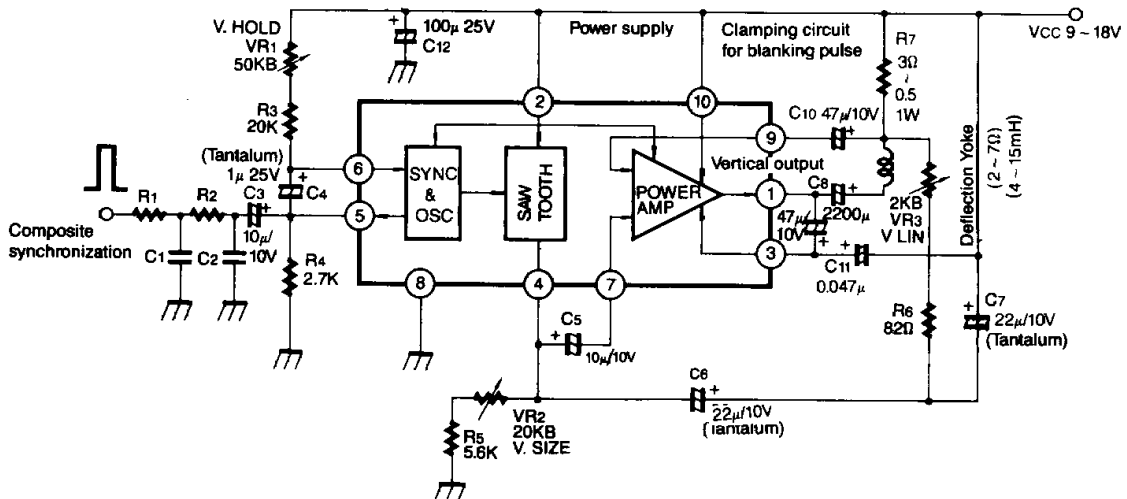

Fig. 1

ABSOLUTE MAXIMUM RATINGS ( $T_a = 25^\circ\text{C}$ )

Characteristic	Symbol	Value	Unit
Supply Voltage	$V_{CC}$	20	V
Output Current	$I_{p-p}$	2	Ap-p
Power Dissipation	$P_{d1}$	1.5 ( $T_a = +75^\circ\text{C}$ ) With aluminum heatsink	W
Power Dissipation	$P_{d2}$	2.15 ( $T_a = +75^\circ\text{C}$ ) With aluminium heatsink (31.6×31.6×1mm t)	W
Operating Temperature	$T_{opr}$	-20 ~ +75	$^\circ\text{C}$
Storage Temperature	$T_{stg}$	-40 ~ +150	$^\circ\text{C}$

ELECTRICAL CHARACTERISTICS ( $V_{CC} = 12\text{V}$ ,  $T_a = 25^\circ\text{C}$ )

Characteristic	Symbol	Test Conditions	Min	Typ	Max	Unit	Test Fig
Circuit Current	$I_{CC}$	No input signal and no load condition	15	30	46	mA	2
Output Terminal Voltage	$V_N$	No input signal and no load condition	5.6	6.0	6.4	V	2
Vertical Oscillation Frequency	$f_v$	Synchronization signal voltage applied at Terminal 5 is $1.3 V_{p-p}$	—	50/60	—	Hz	2
Free-running Frequency	$f_{vo}$	Oscillation capacitor, $1\mu\text{F}$ (Tantalum) resistor, $38.1\text{K}\Omega$	53	60	67	Hz	2
Pull-in Range	$f_p$	With specified integration circuit, applied voltage of synchronization signal is $1.3 V_{p-p}$ at Terminal 5	-10	-12	—	Hz	2
Drift of Free-running Frequency vs. Power Supply Voltage	$\Delta f_{vo}$	Frequency drift from standard frequency ( $f_{vo}$ 60 Hz at $V_{CC} = 12\text{V}$ ) vs. power supply voltage ( $V_{CC} = 12 \pm 2\text{V}$ )	—	—	$\pm 1.0$	Hz	2
Deviation of Pull-in Range vs. Power Supply Voltage	$\Delta f_p$	Deviation from the range for pull in (at $V_{CC} = 12\text{V}$ ) vs. power supply voltage ( $V_{CC} = 12 \pm 2\text{V}$ )	—	—	$\pm 3.0$	Hz	2
Output Saturation Voltage	$V_{sat}$	Output current: 0.7A	—	1.3	1.6	V	2
Output Pulse Width of Terminal 4	$T_o$	Oscillation capacitor, $1\mu\text{F}$ (Tantalum) resistor, $38.1\text{K}\Omega$	300	420	600	$\mu\text{sec}$	2

