

**TRIPLE DIFFUSED PLANER TYPE  
HIGH VOLTAGE, HIGH SPEED SWITCHING**

■ **Features**

- High voltage, High speed switching
- High reliability

■ **Applications**

- Switching regulators
- Ultrasonic generators
- High frequency inverters
- General purpose power amplifiers

■ **Outline Drawings**

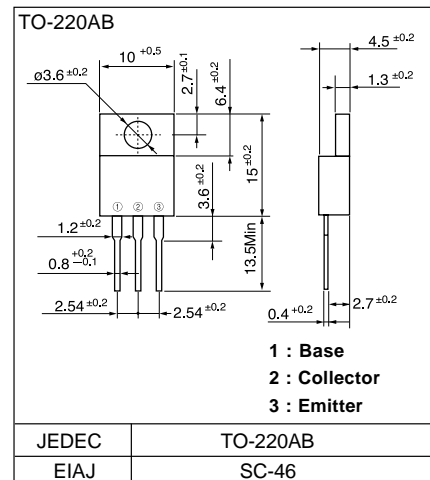

■ **Maximum ratings and characteristics**

- Absolute maximum ratings (Tc=25°C unless otherwise specified)

Item	Symbol	Ratings	Unit
Collector-Base voltage	V <sub>CB0</sub>	450	V
Collector-Emitter voltage	V <sub>CEO</sub>	400	V
Collector-Emitter voltage	V <sub>CEO(SUS)</sub>	400	V
Emitter-Base voltage	V <sub>EBO</sub>	7	V
Collector current	I <sub>C</sub>	5	A
Base current	I <sub>B</sub>	1.5	A
Collector power dissipation	P <sub>C</sub>	40	W
Operating junction temperature	T <sub>j</sub>	+150	°C
Storage temperature	T <sub>stg</sub>	-45 to +150	°C

- Electrical characteristics (Tc =25°C unless otherwise specified)

Item	Symbol	Test Conditions	Min.	Typ.	Max.	Units
Collector-Base voltage	V <sub>CB0</sub>	I <sub>CBO</sub> = 1mA	450			V
Collector-Emitter voltage	V <sub>CEO</sub>	I <sub>CEO</sub> = 10mA	400			V
Collector-Emitter voltage	V <sub>CEO(SUS)</sub>	I <sub>C</sub> = 1A	400	-		V
Emitter-Base voltage	V <sub>EBO</sub>	I <sub>EBO</sub> = 0.1mA	7	-		V
Collector-Base leakage current	I <sub>CBO</sub>	V <sub>CB0</sub> = 450V		-	1.0	mA
Emitter-Base leakage current	I <sub>EBO</sub>	V <sub>EBO</sub> = 7V		-	0.1	mA
D.C. current gain	h <sub>FE</sub>	I <sub>C</sub> = 2A, V <sub>CE</sub> = 5V	10			
Collector-Emitter saturation voltage	V <sub>CE(Sat)</sub>	I <sub>C</sub> = 2A, I <sub>B</sub> = 0.4A			1.2	V
Base-Emitter saturation voltage	V <sub>BE(Sat)</sub>				1.5	V
*1	t <sub>on</sub>	I <sub>C</sub> = 4A, I <sub>B1</sub> = 0.8A			1.0	μs
Switching time	t <sub>stg</sub>	I <sub>B2</sub> = -0.8A, R <sub>L</sub> = 20 ohm			2.0	μs
	t <sub>f</sub>	P <sub>w</sub> = 20μs Duty=<2%			1.0	μs

- Thermal characteristics

Item	Symbol	Test Conditions	Min.	Typ.	Max.	Units
Thermal resistance	R <sub>th(j-c)</sub>	Junction to case			3.0	°C/W

Characteristics

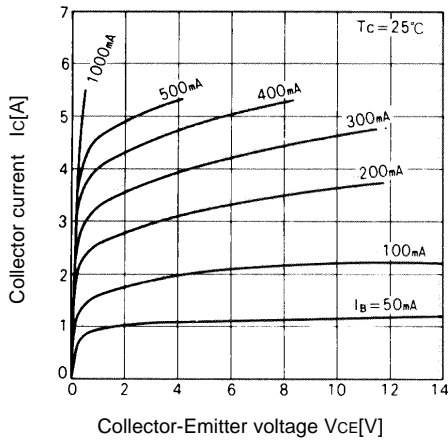

Collector Output Characteristics

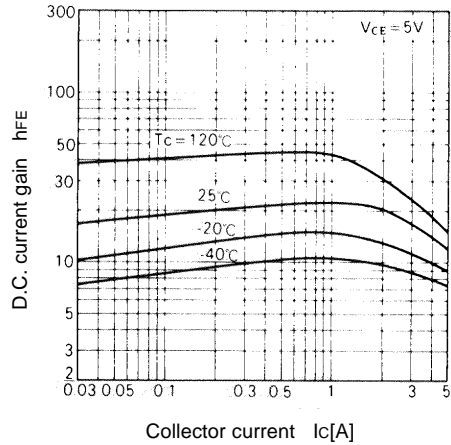

DC Current Gain

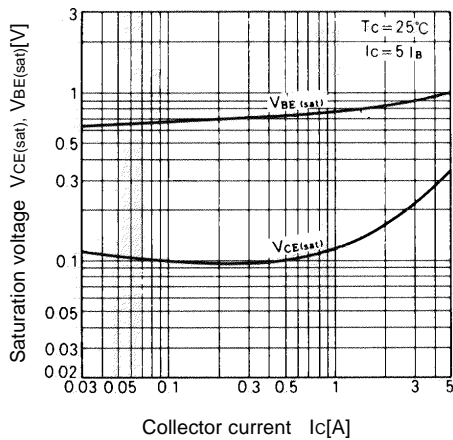

Base and Collector Saturation Voltage

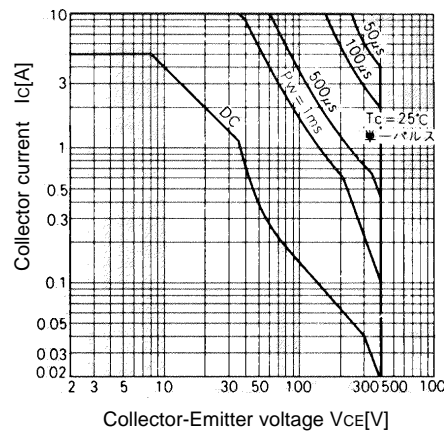

Safe Operating Area

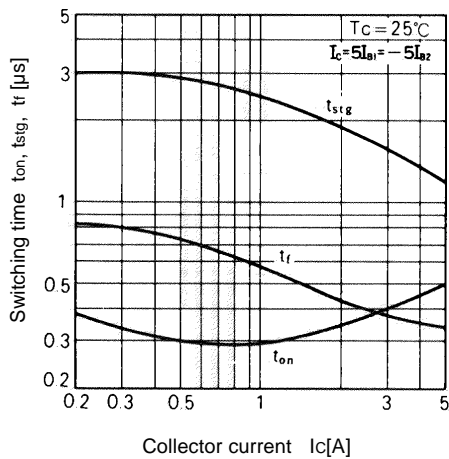

Switching Time

\*1 Switching Time Test Circuit

