

NPN Silicon Germanium RF Transistor
Preliminary data

- High gain low noise RF transistor
- Small package 1.4 x 0.8 x 0.59 mm
- Outstanding noise figure $F = 0.7$ dB at 1.8 GHz
Outstanding noise figure $F = 1.3$ dB at 6 GHz
- Maximum stable gain
 $G_{ms} = 21$ dB at 1.8 GHz
 $G_{ma} = 10$ dB at 6 GHz
- Gold metallization for extra high reliability

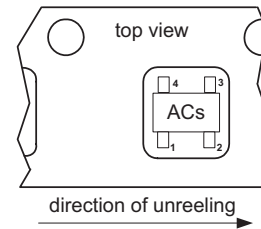
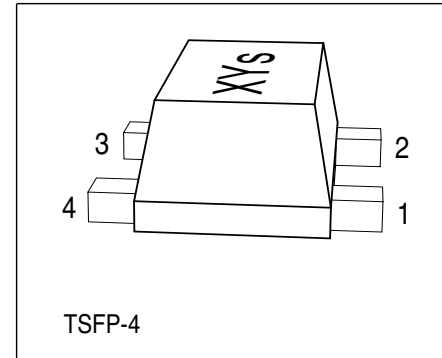

ESD: Electrostatic discharge sensitive device, observe handling precaution!

| Type | Marking | Pin Configuration | | | | | | Package |
|---------------|---------|-------------------|-----|-----|-----|---|---|---------|
| BFP620F E7764 | R2s | 1=B | 2=E | 3=C | 4=E | - | - | TSFP-4 |

Maximum Ratings

| Parameter | Symbol | Value | Unit |
|--|-----------|-------------|------|
| Collector-emitter voltage | V_{CEO} | 2.3 | V |
| Collector-emitter voltage | V_{CES} | 7.5 | |
| Collector-base voltage | V_{CBO} | 7.5 | |
| Emitter-base voltage | V_{EBO} | 1.2 | |
| Collector current | I_C | 80 | mA |
| Base current | I_B | 3 | |
| Total power dissipation ¹⁾ $T_S \leq 96^\circ\text{C}$ | P_{tot} | 185 | mW |
| Junction temperature | T_j | 150 | °C |
| Ambient temperature | T_A | -65 ... 150 | |
| Storage temperature | T_{stg} | -65 ... 150 | |

Thermal Resistance

| Parameter | Symbol | Value | Unit |
|--|------------|------------|------|
| Junction - soldering point ²⁾ | R_{thJS} | ≤ 290 | K/W |

¹⁾ T_S is measured on the collector lead at the soldering point to the pcb

²⁾ For calculation of R_{thJA} please refer to Application Note Thermal Resistance

Electrical Characteristics at $T_A = 25^\circ\text{C}$, unless otherwise specified

| Parameter | Symbol | Values | | | Unit |
|---|---------------|--------|------|------|---------------|
| | | min. | typ. | max. | |
| DC Characteristics | | | | | |
| Collector-emitter breakdown voltage $I_C = 1\text{ mA}, I_B = 0$ | $V_{(BR)CEO}$ | 2.3 | 2.8 | - | V |
| Collector-emitter cutoff current $V_{CE} = 7.5\text{ V}, V_{BE} = 0$ | I_{CES} | - | - | 10 | μA |
| Collector-base cutoff current $V_{CB} = 5\text{ V}, I_E = 0$ | I_{CBO} | - | - | 100 | nA |
| Emitter-base cutoff current $V_{EB} = 0.5\text{ V}, I_C = 0$ | I_{EBO} | - | - | 3 | μA |
| DC current gain $I_C = 50\text{ mA}, V_{CE} = 1.5\text{ V}$ | h_{FE} | 100 | 180 | 320 | - |

Electrical Characteristics at $T_A = 25^\circ\text{C}$, unless otherwise specified

| Parameter | Symbol | Values | | | Unit |
|---|---------------|--------|-------------|------|------|
| | | min. | typ. | max. | |
| AC Characteristics (verified by random sampling) | | | | | |
| Transition frequency $I_C = 50\text{ mA}, V_{CE} = 1.5\text{ V}, f = 1\text{ GHz}$ | f_T | - | 65 | - | GHz |
| Collector-base capacitance $V_{CB} = 2\text{ V}, f = 1\text{ MHz}$ | C_{cb} | - | 0.12 | 0.2 | pF |
| Collector emitter capacitance $V_{CE} = 2\text{ V}, f = 1\text{ MHz}$ | C_{ce} | - | 0.2 | - | |
| Emitter-base capacitance $V_{EB} = 0.5\text{ V}, f = 1\text{ MHz}$ | C_{eb} | - | 0.45 | - | |
| Noise figure $I_C = 5\text{ mA}, V_{CE} = 1.5\text{ V}, f = 1.8\text{ GHz}, Z_S = Z_{Sopt}$ $I_C = 5\text{ mA}, V_{CE} = 1.5\text{ V}, f = 6\text{ GHz}, Z_S = Z_{Sopt}$ | F | - | 0.7 1.3 | - | dB |
| Power gain, maximum stable ¹⁾ $I_C = 50\text{ mA}, V_{CE} = 1.5\text{ V}, Z_S = Z_{Sopt},$ $Z_L = Z_{Lopt}, f = 1.8\text{ GHz}$ | G_{ms} | - | 21 | - | |
| Power gain, maximum available ¹⁾ $I_C = 50\text{ mA}, V_{CE} = 1.5\text{ V}, Z_S = Z_{Sopt},$ $Z_L = Z_{Lopt}, f = 6\text{ GHz}$ | G_{ma} | - | 10 | - | dB |
| Transducer gain $I_C = 50\text{ mA}, V_{CE} = 1.5\text{ V}, Z_S = Z_L = 50\ \Omega,$ $f = 1.8\text{ GHz}$ $I_C = 50\text{ mA}, V_{CE} = 1.5\text{ V}, Z_S = Z_L = 50\ \Omega,$ $f = 6\text{ GHz}$ | $ S_{21e} ^2$ | - | 19.5 9.5 | - | dB |
| Third order intercept point at output ²⁾ $V_{CE} = 2\text{ V}, I_C = 50\text{ mA}, f = 1.8\text{ GHz},$ $Z_S = Z_L = 50\ \Omega$ | IP_3 | - | 25 | - | |
| 1dB Compression point at output $I_C = 50\text{ mA}, V_{CE} = 2\text{ V}, Z_S = Z_L = 50\ \Omega,$ $f = 1.8\text{ GHz}$ | P_{-1dB} | - | 14 | - | |

¹⁾ $G_{ma} = |S_{21e} / S_{12e}| (k - (k^2 - 1)^{1/2}), G_{ms} = |S_{21e} / S_{12e}|$
²⁾ IP_3 value depends on termination of all intermodulation frequency components.
Termination used for this measurement is $50\ \Omega$ from 0.1 MHz to 6 GHz

SPICE Parameter (Gummel-Poon Model, Berkley-SPICE 2G.6 Syntax):

Transistor Chip Data:

| | | | | | | | | |
|-------|---------|----|-------|-----------|-----|--------|-------|----|
| IS = | 0.22 | fA | BF = | 425 | - | NF = | 1.025 | - |
| VAF = | 1000 | V | IKF = | 0.25 | A | ISE = | 21 | fA |
| NE = | 2 | - | BR = | 50 | - | NR = | 1 | - |
| VAR = | 2 | V | IKR = | 10 | mA | ISC = | 18 | pA |
| NC = | 2 | - | RB = | 3.129 | Ω | IRB = | 1.522 | mA |
| RBM = | 2.707 | Ω | RE = | 0.6 | - | RC = | 2.364 | Ω |
| CJE = | 250.7 | fF | VJE = | 0.75 | V | MJE = | 0.3 | - |
| TF = | 1.43 | ps | XTF = | 10 | - | VTF = | 1.5 | V |
| ITF = | 2.4 | A | PTF = | 0 | deg | CJC = | 124.9 | fF |
| VJC = | 0.6 | V | MJC = | 0.5 | - | XCJC = | 1 | - |
| TR = | 0.2 | ns | CJS = | 128.1 | fF | VJS = | 0.52 | V |
| MJS = | 0.5 | - | NK = | -1.42 | - | EG = | 1.078 | eV |
| XTI = | 3 | - | FC = | 0.8 | - | TNOM | 298 | K |
| AF = | 2 | - | KF = | 7.291E-11 | - | | | |
| TITF1 | -0.0065 | - | TITF2 | 1.0E-5 | - | | | |

All parameters are ready to use, no scaling is necessary.

Package Equivalent Circuit:

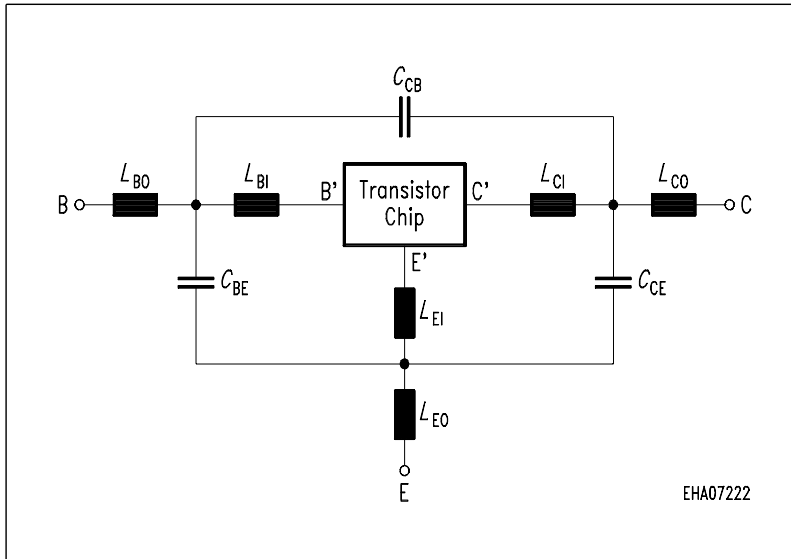

To avoid high complexity of the package equivalent circuit, both emitter leads of TSFP-4 are combined in one electrical connection. R_{LxI} are series resistors for the inductances L_{xI} and K_{xa-yb} are the coupling coefficients between the inductances L_{xa} and L_{yb} .

| | | |
|---------------|-------|----|
| L_{B0} = | 0.22 | nH |
| L_{E0} = | 0.28 | nH |
| L_{C0} = | 0.22 | nH |
| K_{B0-E0} = | 0.1 | - |
| K_{B0-C0} = | 0.01 | - |
| K_{E0-C0} = | 0.11 | - |
| C_{BE} = | 34 | fF |
| C_{BC} = | 2 | fF |
| C_{CE} = | 33 | fF |
| L_{BI} = | 0.42 | nH |
| R_{LBI} = | 0.15 | Ω |
| L_{EI} = | 0.26 | nH |
| R_{LEI} = | 0.11 | Ω |
| L_{CI} = | 0.35 | nH |
| R_{LI} = | 0.13 | Ω |
| K_{BI-EI} = | -0.05 | - |
| K_{BI-CI} = | -0.08 | - |
| K_{EI-CI} = | 0.2 | - |

Valid up to 6GHz

Total power dissipation $P_{tot} = f(T_S)$

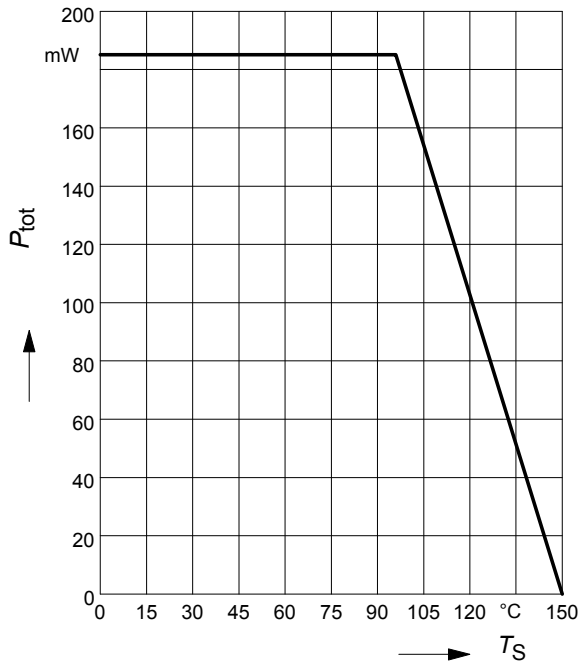

Permissible Pulse Load $R_{thJS} = f(t_p)$

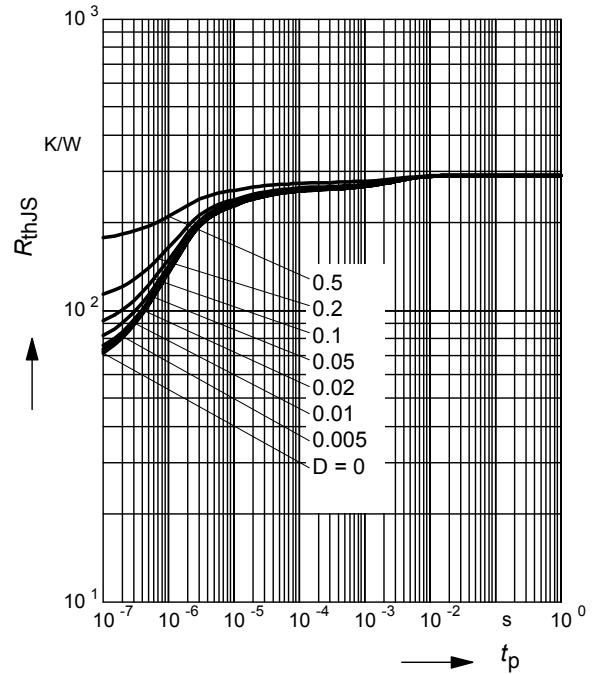

Permissible Pulse Load

$P_{totmax}/P_{totDC} = f(t_p)$

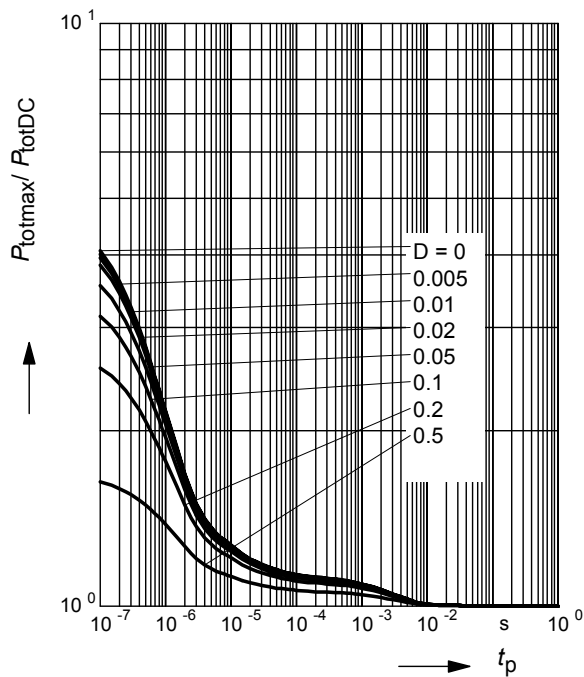

Collector-base capacitance $C_{cb} = f(V_{CB})$

$f = 1\text{MHz}$

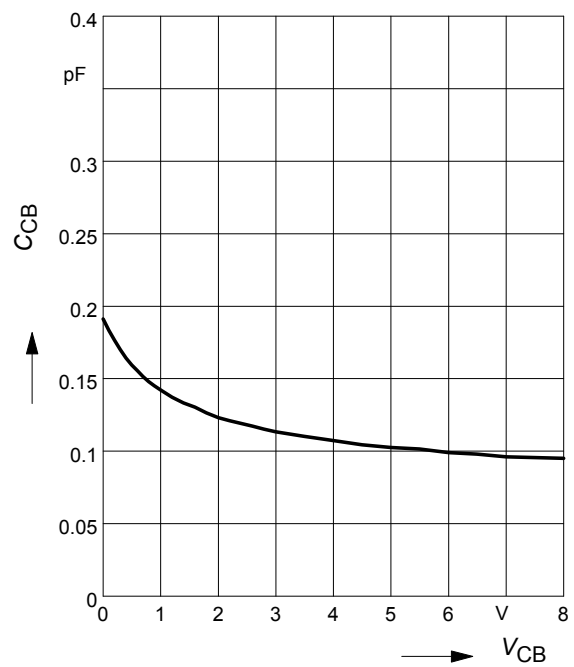

Transition frequency $f_T = f(I_C)$

$f = 1\text{GHz}$

$V_{CE} = \text{Parameter in V}$

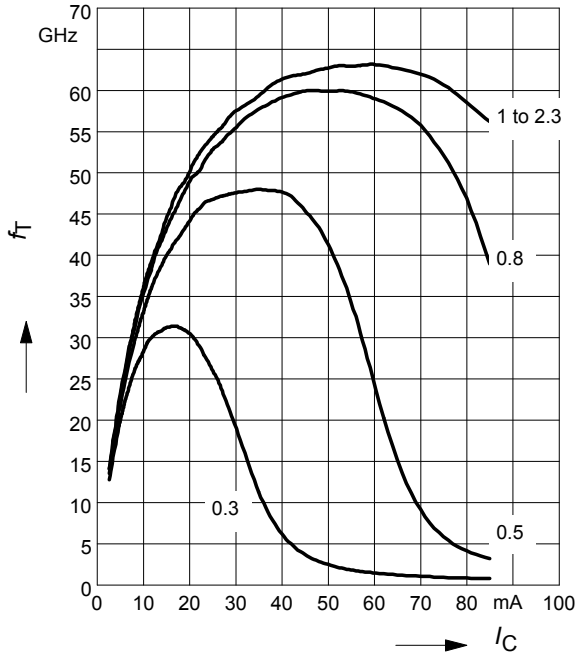

Power gain $G_{ma}, G_{ms} = f(I_C)$

$V_{CE} = 1.5\text{V}$

$f = \text{Parameter in GHz}$

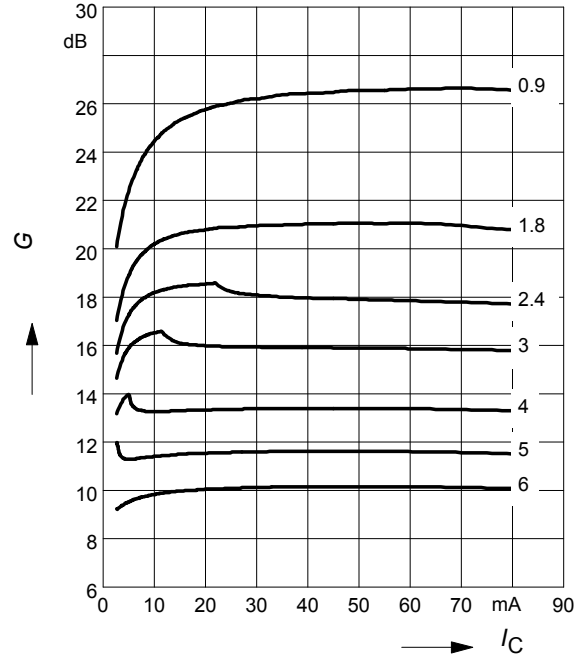

Power Gain $G_{ma}, G_{ms} = f(f)$

$|S_{21}|^2 = f(f)$

$V_{CE} = 1.5\text{V}, I_C = 50\text{mA}$

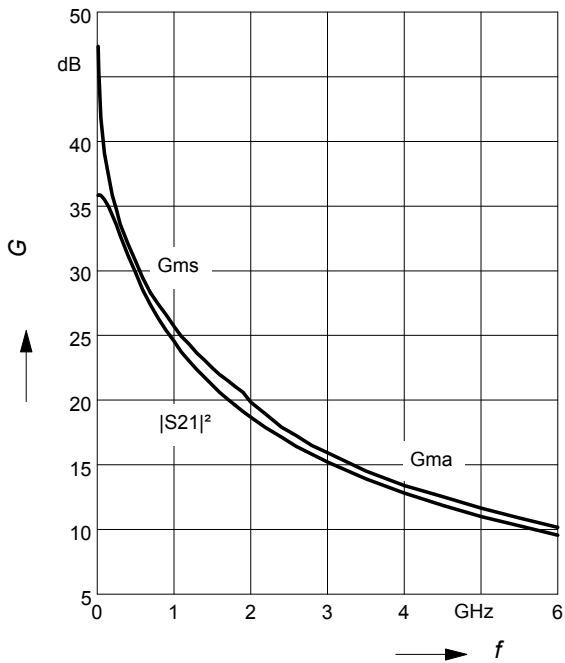

Power gain $G_{ma}, G_{ms} = f(V_{CE})$

$I_C = 50\text{mA}$

$f = \text{Parameter in GHz}$

