

**NPN Silicon Germanium RF Transistor**

- High gain low noise RF transistor
- Provides outstanding performance for a wide range of wireless applications
- Ideal for CDMA and WLAN applications
- Outstanding noise figure  $F = 0.7$  dB at 1.8 GHz  
Outstanding noise figure  $F = 1.3$  dB at 6 GHz
- Maximum stable gain  
 $G_{ms} = 21.5$  dB at 1.8 GHz  
 $G_{ma} = 11$  dB at 6 GHz
- Gold metallization for extra high reliability

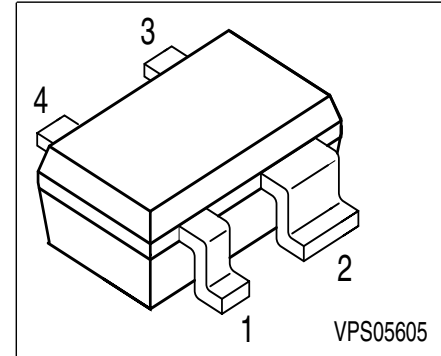

**ESD:** Electrostatic discharge sensitive device, observe handling precaution!

Type	Marking	Pin Configuration						Package
BFP620_E7764	R2s	1=B	2=E	3=C	4=E	-	-	SOT343

**Maximum Ratings**

Parameter	Symbol	Value	Unit
Collector-emitter voltage	$V_{CEO}$	2.3	V
Collector-emitter voltage	$V_{CES}$	7.5	
Collector-base voltage	$V_{CBO}$	7.5	
Emitter-base voltage	$V_{EBO}$	1.2	
Collector current	$I_C$	80	mA
Base current	$I_B$	3	
Total power dissipation <sup>1)</sup> $T_S \leq 95^\circ\text{C}$	$P_{tot}$	185	mW
Junction temperature	$T_j$	150	°C
Ambient temperature	$T_A$	-65 ... 150	
Storage temperature	$T_{stg}$	-65 ... 150	

**Thermal Resistance**

Parameter	Symbol	Value	Unit
Junction - soldering point <sup>2)</sup>	$R_{thJS}$	$\leq 300$	K/W

<sup>1)</sup>  $T_S$  is measured on the collector lead at the soldering point to the pcb

<sup>2)</sup> For calculation of  $R_{thJA}$  please refer to Application Note Thermal Resistance

**Electrical Characteristics** at  $T_A = 25^\circ\text{C}$ , unless otherwise specified

Parameter	Symbol	Values			Unit
		min.	typ.	max.	
<b>DC Characteristics</b>					
Collector-emitter breakdown voltage $I_C = 1 \text{ mA}, I_B = 0$	$V_{(BR)CEO}$	2.3	2.8	-	V
Collector-emitter cutoff current $V_{CE} = 7.5 \text{ V}, V_{BE} = 0$	$I_{CES}$	-	-	10	$\mu\text{A}$
Collector-base cutoff current $V_{CB} = 5 \text{ V}, I_E = 0$	$I_{CBO}$	-	-	100	nA
Emitter-base cutoff current $V_{EB} = 0.5 \text{ V}, I_C = 0$	$I_{EBO}$	-	-	3	$\mu\text{A}$
DC current gain $I_C = 50 \text{ mA}, V_{CE} = 1.5 \text{ V}$	$h_{FE}$	100	180	320	-

**Electrical Characteristics at  $T_A = 25^\circ\text{C}$ , unless otherwise specified**

Parameter	Symbol	Values			Unit
		min.	typ.	max.	
<b>AC Characteristics (verified by random sampling)</b>					
Transition frequency $I_C = 50\text{ mA}$ , $V_{CE} = 1.5\text{ V}$ , $f = 1\text{ GHz}$	$f_T$	-	65	-	GHz
Collector-base capacitance $V_{CB} = 2\text{ V}$ , $f = 1\text{ MHz}$	$C_{cb}$	-	0.12	0.2	pF
Collector emitter capacitance $V_{CE} = 2\text{ V}$ , $f = 1\text{ MHz}$	$C_{ce}$	-	0.22	-	
Emitter-base capacitance $V_{EB} = 0.5\text{ V}$ , $f = 1\text{ MHz}$	$C_{eb}$	-	0.46	-	
Noise figure $I_C = 5\text{ mA}$ , $V_{CE} = 1.5\text{ V}$ , $f = 1.8\text{ GHz}$ , $Z_S = Z_{Sopt}$ $I_C = 5\text{ mA}$ , $V_{CE} = 1.5\text{ V}$ , $f = 6\text{ GHz}$ , $Z_S = Z_{Sopt}$	$F$	-	0.7 1.3	-	dB
Power gain, maximum stable <sup>1)</sup> $I_C = 50\text{ mA}$ , $V_{CE} = 1.5\text{ V}$ , $Z_S = Z_{Sopt}$ , $Z_L = Z_{Lopt}$ , $f = 1.8\text{ GHz}$	$G_{ms}$	-	21.5	-	
Power gain, maximum available <sup>1)</sup> $I_C = 50\text{ mA}$ , $V_{CE} = 1.5\text{ V}$ , $Z_S = Z_{Sopt}$ , $Z_L = Z_{Lopt}$ , $f = 6\text{ GHz}$	$G_{ma}$	-	11	-	dB
Transducer gain $I_C = 50\text{ mA}$ , $V_{CE} = 1.5\text{ V}$ , $Z_S = Z_L = 50\ \Omega$ , $f = 1.8\text{ GHz}$ $I_C = 50\text{ mA}$ , $V_{CE} = 1.5\text{ V}$ , $Z_S = Z_L = 50\ \Omega$ , $f = 6\text{ GHz}$	$ S_{21e} ^2$	-	20 9.5	-	dB
Third order intercept point at output <sup>2)</sup> $V_{CE} = 2\text{ V}$ , $I_C = 50\text{ mA}$ , $f = 1.8\text{ GHz}$ , $Z_S = Z_L = 50\ \Omega$	$IP_3$	-	25	-	
1dB Compression point at output $I_C = 50\text{ mA}$ , $V_{CE} = 2\text{ V}$ , $Z_S = Z_L = 50\ \Omega$ , $f = 1.8\text{ GHz}$	$P_{-1dB}$	-	15	-	

$$^1G_{ma} = |S_{21e}| / |S_{12e}| (k - (k^2 - 1)^{1/2}), G_{ms} = |S_{21e}| / |S_{12e}|$$

<sup>2</sup>IP3 value depends on termination of all intermodulation frequency components.  
Termination used for this measurement is 50Ω from 0.1 MHz to 6 GHz

**SPICE Parameter (Gummel-Poon Model, Berkley-SPICE 2G.6 Syntax):**
**Transistor Chip Data:**

IS =	0.22	fA	BF =	425	-	NF =	1.025	-
VAF =	1000	V	IKF =	0.25	A	ISE =	21	fA
NE =	2	-	BR =	50	-	NR =	1	-
VAR =	2	V	IKR =	10	mA	ISC =	18	pA
NC =	2	-	RB =	3.129	Ω	IRB =	1.522	mA
RBM =	2.707	Ω	RE =	0.6	-	RC =	2.364	Ω
CJE =	250.7	fF	VJE =	0.75	V	MJE =	0.3	-
TF =	1.43	ps	XTF =	10	-	VTF =	1.5	V
ITF =	2.4	A	PTF =	0	deg	CJC =	124.9	fF
VJC =	0.6	V	MJC =	0.5	-	XCJC =	1	-
TR =	0.2	ns	CJS =	128.1	fF	VJS =	0.52	V
MJS =	0.5	-	NK =	-1.42	-	EG =	1.078	eV
XTI =	3	-	FC =	0.8	-	TNOM =	298	K
AF =	2	-	KF =	7.291E-11	-			
TITF1 =	-0.0065	-	TITF2 =	1.0E-5	-			

All parameters are ready to use, no scaling is necessary.

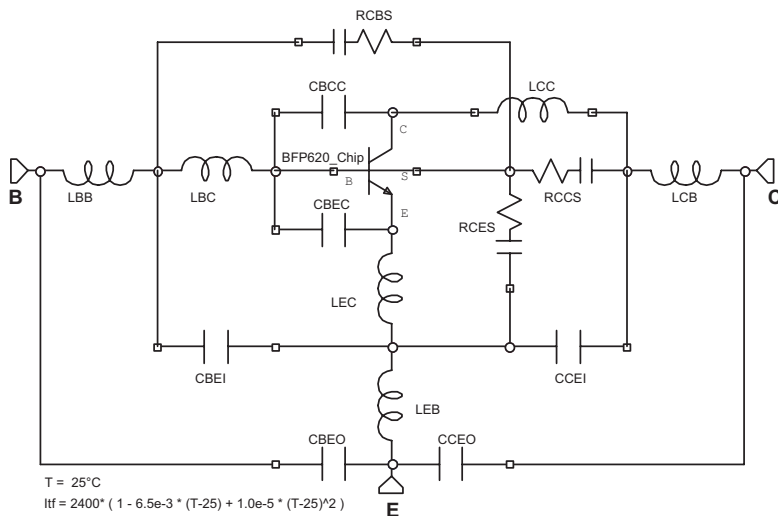
**Package Equivalent Circuit:**

For examples and ready to use parameters please contact your local Infineon Technologies distributor or sales office to obtain a Infineon Technologies CD-ROM or see Internet: <http://www.infineon.com/silicondiscretres>

LBC =	60	pH
LCC =	50	pH
LEC =	15	pH
LBB =	764.5	pH
LCB =	725.4	pH
LEB =	259.6	pH
CBEC =	98.4	fF
CBCC =	55.9	fF
CES =	140	fF
CBS =	54	fF
CCS =	50	fF
CCEO =	106.5	fF
CBEI =	106.7	fF
CCEI =	132.4	fF
CBEI =	99.6	fF
RBS =	1200	Ω
RCS =	1200	Ω
RES =	300	Ω

Valid up to 6GHz

**Total power dissipation  $P_{tot} = f(T_S)$**

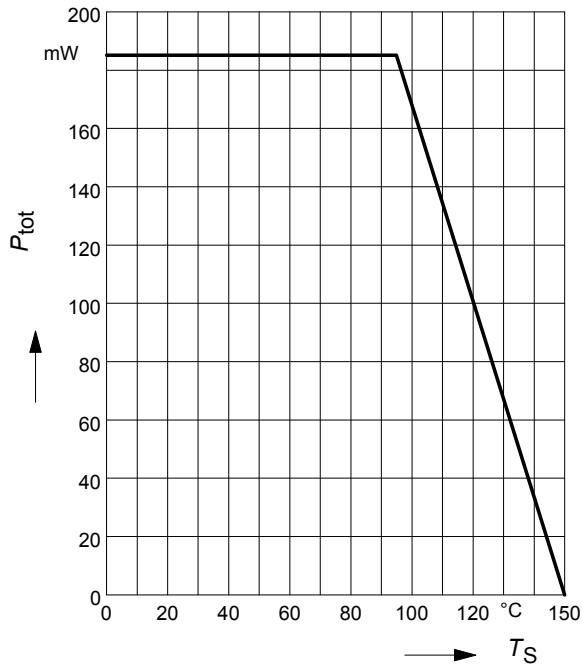

**Permissible Pulse Load  $R_{thJS} = f(t_p)$**

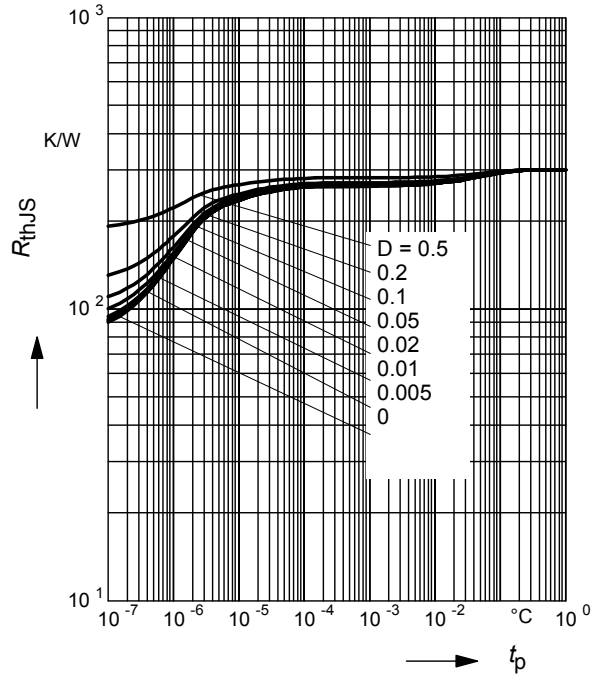

**Permissible Pulse Load**

$P_{totmax}/P_{totDC} = f(t_p)$

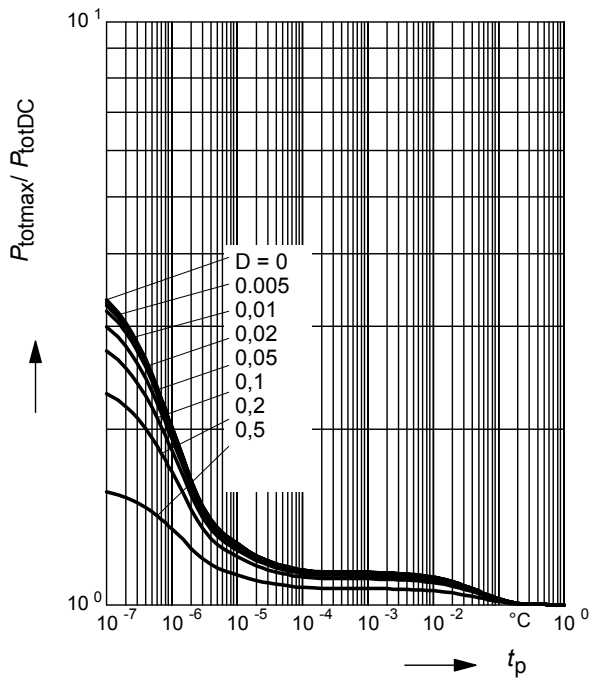

**Collector-base capacitance  $C_{cb} = f(V_{CB})$**

$f = 1\text{MHz}$

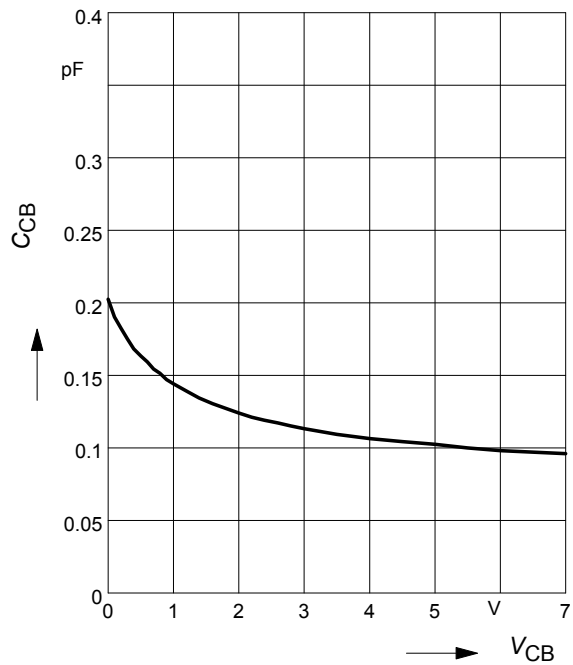

**Third order Intercept Point  $IP_3=f(I_C)$**

(Output,  $Z_S=Z_L=50\Omega$ )

$V_{CE}$  = parameter,  $f = 900\text{MHz}$  -

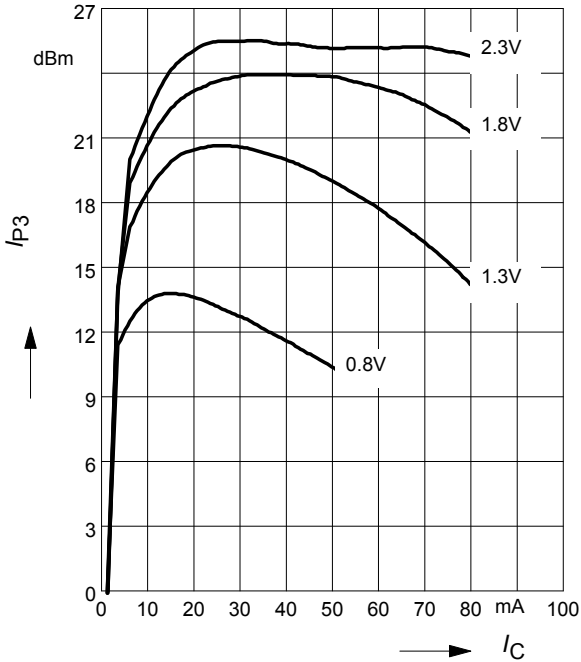

**Transition frequency  $f_T=f(I_C)$**

$f = 1\text{GHz}$

$V_{CE}$  = Parameter in V

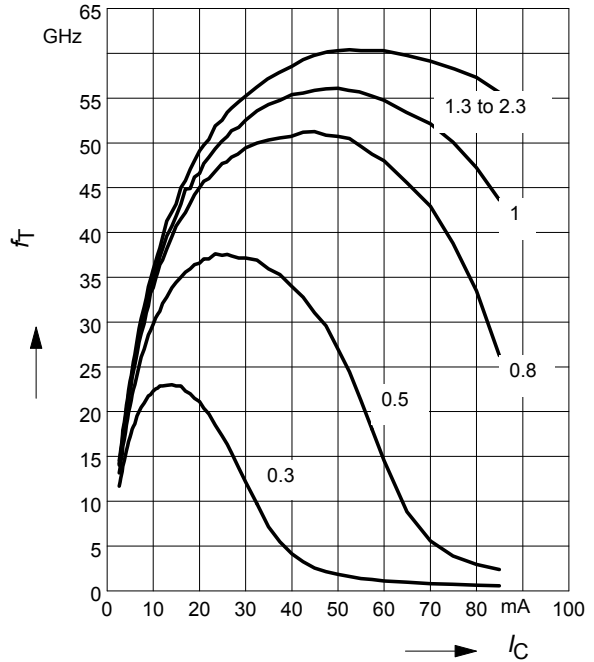

**Power gain  $G_{ma}, G_{ms} = f(I_C)$**

$V_{CE} = 1.5\text{V}$

$f$  = Parameter in GHz

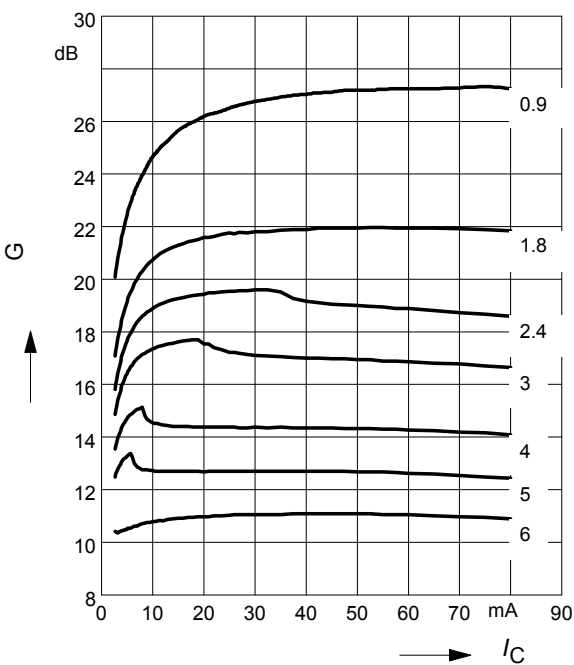

**Power Gain  $G_{ma}, G_{ms} = f(f)$ ,**

$|S_{21}|^2 = f(f)$

$V_{CE} = 1.5\text{V}, I_C = 50\text{mA}$

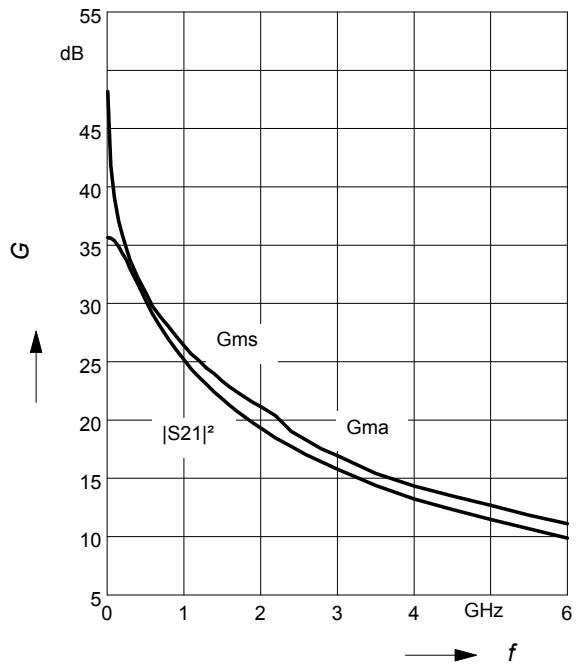

Power gain  $G_{ma}$ ,  $G_{ms} = f(V_{CE})$

$I_C = 50\text{mA}$

$f =$  Parameter in GHz

