

MJE18604D2

POWER TRANSISTORS
3 AMPERES
1600 VOLTS
100 WATTS

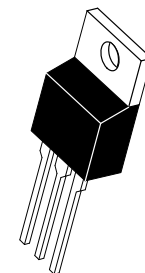
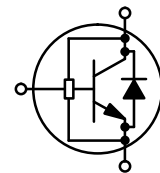

CASE 221A-06
TO-220AB

Advance Information

High Speed, High Gain Bipolar NPN Power Transistor with Integrated Collector-Emitter Diode and Built-in Efficient Antisaturation Network for 1600 V Applications

The MJE18604D2 is state-of-art High Speed High gain BIPolar transistor (H2BIP). Tight dynamic characteristics and lot to lot low spread (± 150 ns on storage time) make it ideally suitable for light ballast applications. Therefore, there is no more a need to guarantee an h_{fe} window.

Main features:

- Low Base Drive Requirement
- High DC Current Gain (30 Typical) @ $I_C = 400$ mA
- Extremely Low Storage Time Min/Max Guarantees Due to the Internal Active Antisaturation (H2BIP) Structure which Minimizes the Spread
- Integrated Collector-Emitter Free Wheeling Diode Matched with the Power Transistor
- Fully Characterized and Guaranteed Dynamic $V_{CE(sat)}$
- "6 Sigma" Process Providing Tight and Reproducible Parameter Spreads

MAXIMUM RATINGS

Rating	Symbol	Value	Unit
Collector-Emitter Breakdown Voltage	V_{CEO}	800	Vdc
Collector-Emitter Sustaining Voltage @ $R = 200 \Omega$	V_{CER}	800	Vdc
Collector-Base Breakdown Voltage	V_{CBO}	1600	Vdc
Collector-Emitter Breakdown Voltage	V_{CES}	1600	Vdc
Emitter-Base Voltage	V_{EBO}	12	Vdc
Collector Current — Continuous	I_C	3	Adc
— Peak (1)	I_{CM}	8	
Base Current — Continuous	I_B	2	Adc
— Peak (1)	I_{BM}	4	
*Total Device Dissipation @ $T_C = 25^\circ C$	P_D	100	Watt
*Derate above $25^\circ C$		0.8	W/ $^\circ C$
Operating and Storage Temperature	T_J, T_{stg}	-65 to 150	$^\circ C$

THERMAL CHARACTERISTICS

Thermal Resistance — Junction to Case	$R_{\theta JC}$	1.25	$^\circ C/W$
— Junction to Ambient	$R_{\theta JA}$	62.5	
Maximum Lead Temperature for Soldering Purposes: 1/8" from case for 5 seconds	T_L	260	$^\circ C$

(1) Pulse Test: Pulse Width = 5 ms, Duty Cycle $\leq 10\%$.

This document contains information on a new product. Specifications and information herein are subject to change without notice.

Designer's and SWITCHMODE are trademarks of Motorola, Inc.

MJE18604D2

ELECTRICAL CHARACTERISTICS (T_C = 25°C unless otherwise noted)

Characteristic	Symbol	Min	Typ	Max	Unit
OFF CHARACTERISTICS					
Collector–Emitter Sustaining Voltage (I _C = 100 mA, L = 25 mH, R _{BE} = 200 Ω)	V _{CER(sus)}	800			Vdc
Collector–Base Breakdown Voltage (I _{CBO} = 1 mA)	V _{CBO}	1600			Vdc
Emitter–Base Breakdown Voltage (I _{EBO} = 1 mA)	V _{EBO}	12	14		Vdc
Collector Cutoff Current (V _{CBO} = Rated V _{CBO} , I _B = 0)	I _{CBO}			100	μAdc
Collector Cutoff Current (V _{CE} = Rated V _{CES} , V _{EB} = 0) (V _{CE} = 1300 V, V _{EB} = 0)	I _{CES}			100 1000 100	μAdc
Emitter–Cutoff Current (V _{EB} = 11 Vdc, I _C = 0)	I _{EBO}			500	μAdc

ON CHARACTERISTICS

Base–Emitter Saturation Voltage (I _C = 0.5 Adc, I _B = 0.1 Adc) (I _C = 1 Adc, I _B = 0.1 Adc) (I _C = 2 Adc, I _B = 0.4 Adc)	@ T _C = 25°C @ T _C = 125°C	V _{BE(sat)}		0.8 0.6	1.1 1	Vdc
	@ T _C = 25°C @ T _C = 125°C			0.8 1	1 1	
	@ T _C = 25°C @ T _C = 125°C			0.9 0.8	1.2 1.1	
Collector–Emitter Saturation Voltage (I _C = 250 mAdc, I _B = 25 mAdc) (I _C = 0.5 Adc, I _B = 50 mAdc) (I _C = 0.8 Adc, I _B = 80 mAdc)	@ T _C = 25°C @ T _C = 125°C	V _{CE(sat)}		1 1.7	1.25	Vdc
	@ T _C = 25°C @ T _C = 125°C			2.1 4	2.4	
	@ T _C = 25°C @ T _C = 125°C			3.7 5	5	
DC Current Gain (I _C = 0.4 Adc, V _{CE} = 3 Vdc) (I _C = 5 mAdc, V _{CE} = 10 Vdc)	@ T _C = 25°C @ T _C = 125°C	h _{FE}	20 6	10	40	—
	@ T _C = 25°C @ T _C = 125°C		20 20	35 55		

DYNAMIC SATURATION VOLTAGE

Dynamic Saturation Voltage: Determined 1 μs and 3 μs respectively after rising I _{B1} reaches 90% of final I _{B1}	I _C = 0.3 Adc I _{B1} = 50 mA V _{CC} = 300 V	@ 1 μs	@ T _C = 25°C @ T _C = 125°C	V _{CE(dsat)}		4.7 9.3	V
		@ 3 μs	@ T _C = 25°C @ T _C = 125°C			2.6 5.4	
	I _C = 0.5 Adc I _{B1} = 50 mA V _{CC} = 300 V	@ 1 μs	@ T _C = 25°C @ T _C = 125°C			9.7 18	
		@ 3 μs	@ T _C = 25°C @ T _C = 125°C			6.4 12.3	

DIODE CHARACTERISTICS

Forward Diode Voltage (I _{EC} = 0.4 Adc) (I _{EC} = 1 Adc)	@ T _C = 25°C @ T _C = 125°C	V _{EC}		0.9 0.6	1.2	V
	@ T _C = 25°C @ T _C = 125°C			1.05 0.7	1.5	
Forward Recovery Time (I _F = 0.4 Adc, di/dt = 10 A/μs) (I _F = 1.0 Adc, di/dt = 10 A/μs)	@ T _C = 25°C @ T _C = 125°C	t _{fr}		0.9 1.5		μs
	@ T _C = 25°C @ T _C = 125°C			1.15 1.6		

ELECTRICAL CHARACTERISTICS ($T_C = 25^\circ\text{C}$ unless otherwise noted)

Characteristic	Symbol	Min	Typ	Max	Unit
DYNAMIC CHARACTERISTICS					
Current Gain Bandwidth ($I_C = 0.5 \text{ Adc}$, $V_{CE} = 10 \text{ Vdc}$, $f = 1 \text{ MHz}$)	f_T		13		MHz
Output Capacitance ($V_{CB} = 10 \text{ Vdc}$, $I_E = 0$, $f = 1 \text{ MHz}$)	C_{ob}		230	500	pF
Input Capacitance ($V_{CE} = 8 \text{ Vdc}$)	C_{ib}		480	1000	pF

SWITCHING CHARACTERISTICS: Resistive Load (D.C. $\leq 10\%$, Pulse Width = 40 μs)

Delay Time	$I_C = 0.5 \text{ Adc}$ $I_{B1} = 66 \text{ mAdc}$ $I_{B2} = 390 \text{ mAdc}$ $V_{CC} = 125 \text{ V}$	@ $T_C = 25^\circ\text{C}$ @ $T_C = 125^\circ\text{C}$	t_d		95 110	150	ns	
Rise Time		@ $T_C = 25^\circ\text{C}$ @ $T_C = 125^\circ\text{C}$	t_r		475 900	750	ns	
Storage Time		@ $T_C = 25^\circ\text{C}$ @ $T_C = 125^\circ\text{C}$	t_s	400		910	700	ns
Fall Time		@ $T_C = 25^\circ\text{C}$ @ $T_C = 125^\circ\text{C}$	t_f			675 775	850	ns
Turn-on Time	$I_C = 0.3 \text{ Adc}$ $I_{B1} = 50 \text{ mAdc}$ $I_{B2} = 50 \text{ mAdc}$ $V_{CC} = 125 \text{ V}$	@ $T_C = 25^\circ\text{C}$ @ $T_C = 125^\circ\text{C}$	t_{on}		440 570		ns	
Storage Time		@ $T_C = 25^\circ\text{C}$ @ $T_C = 125^\circ\text{C}$	t_s		4 5.9		μs	
Fall Time		@ $T_C = 25^\circ\text{C}$ @ $T_C = 125^\circ\text{C}$	t_f			375 675		ns
Turn-off Time		@ $T_C = 25^\circ\text{C}$ @ $T_C = 125^\circ\text{C}$	t_{off}			4.5 6.6		μs
Turn-on Time	$I_C = 0.3 \text{ Adc}$ $I_{B1} = 50 \text{ mAdc}$ $I_{B2} = 150 \text{ mAdc}$ $V_{CC} = 125 \text{ V}$	@ $T_C = 25^\circ\text{C}$ @ $T_C = 125^\circ\text{C}$	t_{on}		465 550	600	ns	
Storage Time		@ $T_C = 25^\circ\text{C}$ @ $T_C = 125^\circ\text{C}$	t_s	500		1800	800	ns
Fall Time		@ $T_C = 25^\circ\text{C}$ @ $T_C = 125^\circ\text{C}$	t_f			800 550	1000	ns
Turn-off Time		@ $T_C = 25^\circ\text{C}$ @ $T_C = 125^\circ\text{C}$	t_{off}			1.5 2.4	1.75	μs
Turn-on Time	$I_C = 0.5 \text{ Adc}$ $I_{B1} = 50 \text{ mAdc}$ $I_{B2} = 50 \text{ mAdc}$ $V_{CC} = 125 \text{ V}$	@ $T_C = 25^\circ\text{C}$ @ $T_C = 125^\circ\text{C}$	t_{on}		550 1300		ns	
Storage Time		@ $T_C = 25^\circ\text{C}$ @ $T_C = 125^\circ\text{C}$	t_s			4.35 5		μs
Fall Time		@ $T_C = 25^\circ\text{C}$ @ $T_C = 125^\circ\text{C}$	t_f			500 2000		ns
Turn-off Time		@ $T_C = 25^\circ\text{C}$ @ $T_C = 125^\circ\text{C}$	t_{off}			4.8 7		μs
Delay Time	$I_C = 0.5 \text{ Adc}$ $I_{B1} = 50 \text{ mAdc}$ $I_{B2} = 250 \text{ mAdc}$ $V_{CC} = 125 \text{ V}$	@ $T_C = 25^\circ\text{C}$	t_d		100	300	ns	
Rise Time		@ $T_C = 25^\circ\text{C}$	t_r		300	800	ns	
Storage Time		@ $T_C = 25^\circ\text{C}$	t_s		1	1.2	μs	
Fall Time		@ $T_C = 25^\circ\text{C}$	t_f		200	350	ns	

MJE18604D2

ELECTRICAL CHARACTERISTICS (T_C = 25°C unless otherwise noted)

Characteristic	Symbol	Min	Typ	Max	Unit
SWITCHING CHARACTERISTICS: Inductive Load (V_{CC} = 15 V)					
Fall Time	I _C = 300 mA I _{B1} = 50 mA I _{B2} = 50 mA V _Z = 300 V L _C = 200 μH	@ T _C = 25°C	t _f	170	ns
Storage Time		@ T _C = 125°C	t _s	1.7 2.7	μs
Crossover Time		@ T _C = 25°C @ T _C = 125°C	t _c	150 400	ns
Fall Time	I _C = 300 mA I _{B1} = 50 mA I _{B2} = 150 mA V _Z = 300 V L _C = 200 μH	@ T _C = 25°C	t _f	160	250
Storage Time		@ T _C = 125°C	t _s	0.7 1.1	1
Crossover Time		@ T _C = 25°C @ T _C = 125°C	t _c	160 160	250
Fall Time	I _C = 500 mA I _{B1} = 50 mA I _{B2} = 50 mA V _Z = 300 V L _C = 200 μH	@ T _C = 25°C	t _f	165	700
Storage Time		@ T _C = 125°C	t _s	3 4.1	μs
Crossover Time		@ T _C = 25°C @ T _C = 125°C	t _c	200 800	ns
Fall Time	I _C = 500 mA I _{B1} = 50 mA I _{B2} = 250 mA V _Z = 300 V L _C = 200 μH	@ T _C = 25°C	t _f	110	175
Storage Time		@ T _C = 125°C	t _s	0.7 1.8	1
Crossover Time		@ T _C = 25°C @ T _C = 125°C	t _c	130 250	200

PACKAGE DIMENSIONS

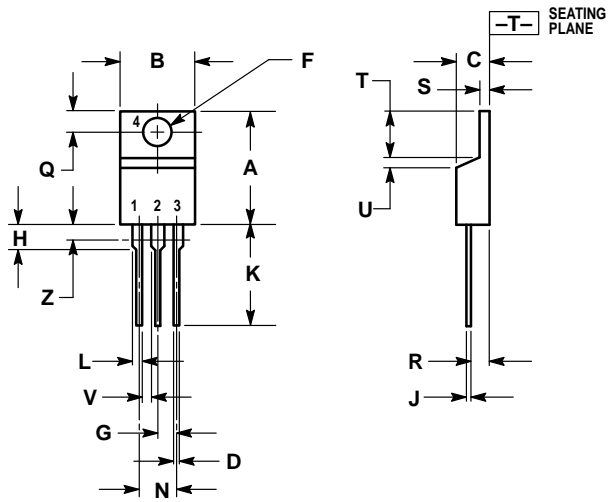

- NOTES:
1. DIMENSIONING AND TOLERANCING PER ANSI Y14.5M, 1982.
 2. CONTROLLING DIMENSION: INCH.
 3. DIMENSION Z DEFINES A ZONE WHERE ALL BODY AND LEAD IRREGULARITIES ARE ALLOWED.

DIM	INCHES		MILLIMETERS	
	MIN	MAX	MIN	MAX
A	0.570	0.620	14.48	15.75
B	0.380	0.405	9.66	10.28
C	0.160	0.190	4.07	4.82
D	0.025	0.035	0.64	0.88
F	0.142	0.147	3.61	3.73
G	0.095	0.105	2.42	2.66
H	0.110	0.155	2.80	3.93
J	0.018	0.025	0.46	0.64
K	0.500	0.562	12.70	14.27
L	0.045	0.060	1.15	1.52
N	0.190	0.210	4.83	5.33
Q	0.100	0.120	2.54	3.04
R	0.080	0.110	2.04	2.79
S	0.045	0.055	1.15	1.39
T	0.235	0.255	5.97	6.47
U	0.000	0.050	0.00	1.27
V	0.045	—	1.15	—
Z	—	0.080	—	2.04

- STYLE 1:
 PIN 1: BASE
 2. COLLECTOR
 3. EMITTER
 4. COLLECTOR

CASE 221A-06
 TO-220AB
 ISSUE Y

Motorola reserves the right to make changes without further notice to any products herein. Motorola makes no warranty, representation or guarantee regarding the suitability of its products for any particular purpose, nor does Motorola assume any liability arising out of the application or use of any product or circuit, and specifically disclaims any and all liability, including without limitation consequential or incidental damages. "Typical" parameters can and do vary in different applications. All operating parameters, including "Typicals" must be validated for each customer application by customer's technical experts. Motorola does not convey any license under its patent rights nor the rights of others. Motorola products are not designed, intended, or authorized for use as components in systems intended for surgical implant into the body, or other applications intended to support or sustain life, or for any other application in which the failure of the Motorola product could create a situation where personal injury or death may occur. Should Buyer purchase or use Motorola products for any such unintended or unauthorized application, Buyer shall indemnify and hold Motorola and its officers, employees, subsidiaries, affiliates, and distributors harmless against all claims, costs, damages, and expenses, and reasonable attorney fees arising out of, directly or indirectly, any claim of personal injury or death associated with such unintended or unauthorized use, even if such claim alleges that Motorola was negligent regarding the design or manufacture of the part. Motorola and  are registered trademarks of Motorola, Inc. Motorola, Inc. is an Equal Opportunity/Affirmative Action Employer.

How to reach us:

USA / EUROPE: Motorola Literature Distribution;
P.O. Box 20912; Phoenix, Arizona 85036. 1-800-441-2447

JAPAN: Nippon Motorola Ltd.; Tatsumi-SPD-JLDC, Toshikatsu Otsuki,
6F Seibu-Butsuryu-Center, 3-14-2 Tatsumi Koto-Ku, Tokyo 135, Japan. 03-3521-8315

MFAX: RMFAX0@email.sps.mot.com – TOUCHTONE (602) 244-6609
INTERNET: <http://Design-NET.com>

HONG KONG: Motorola Semiconductors H.K. Ltd.; 8B Tai Ping Industrial Park,
51 Ting Kok Road, Tai Po, N.T., Hong Kong. 852-26629298

