2SC5543

Silicon NPN Epitaxial
VHF / UHF wide band amplifier

HITACHI

ADE-208-690 (Z)
1st. Edition
Nov. 1998

Features

- Super compact package;
(1.4 × 0.8 × 0.59mm)
- Capable low voltage operation ;
($V_{CE} = 1V$)

Outline

MFPAK

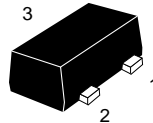

1. Emitter
2. Base
3. Collector

Note: Marking is "YA-".

2SC5543

Absolute Maximum Ratings (Ta = 25°C)

Item	Symbol	Ratings	Unit
Collector to base voltage	V _{CBO}	15	V
Collector to emitter voltage	V _{CEO}	8	V
Emitter to base voltage	V _{EBO}	1.5	V
Collector current	I _C	20	mA
Collector power dissipation	P _c	80	mW
Junction temperature	T _j	150	°C
Storage temperature	T _{stg}	-55 to +150	°C

Electrical Characteristics (Ta = 25°C)

Item	Symbol	Min	Typ	Max	Unit	Test Conditions
Collector cutoff current	I _{CBO}	—	—	10	μA	V _{CB} = 15V, I _E = 0
Collector cutoff current	I _{CEO}	—	—	1	mA	V _{CE} = 8V, R _{BE} = ∞
Emitter cutoff current	I _{EBO}	—	—	10	μA	V _{EB} = 1.5V, I _C = 0
DC current transfer ratio	h _{FE}	85	—	170	V	V _{CE} = 1V, I _C = 5mA
Collector output capacitance	C _{ob}	—	0.51	0.9	pF	V _{CB} = 1V, I _E = 0 f = 1MHz
Gain bandwidth product	f _T	5.5	8.5	—	GHz	V _{CE} = 1V, I _C = 5mA
Power gain	PG	11	13.7	—	dB	V _{CE} = 1V, I _C = 5mA f = 900MHz
Noise figure	NF	—	1.1	2.5	dB	V _{CE} = 1V, I _C = 5mA f = 900MHz

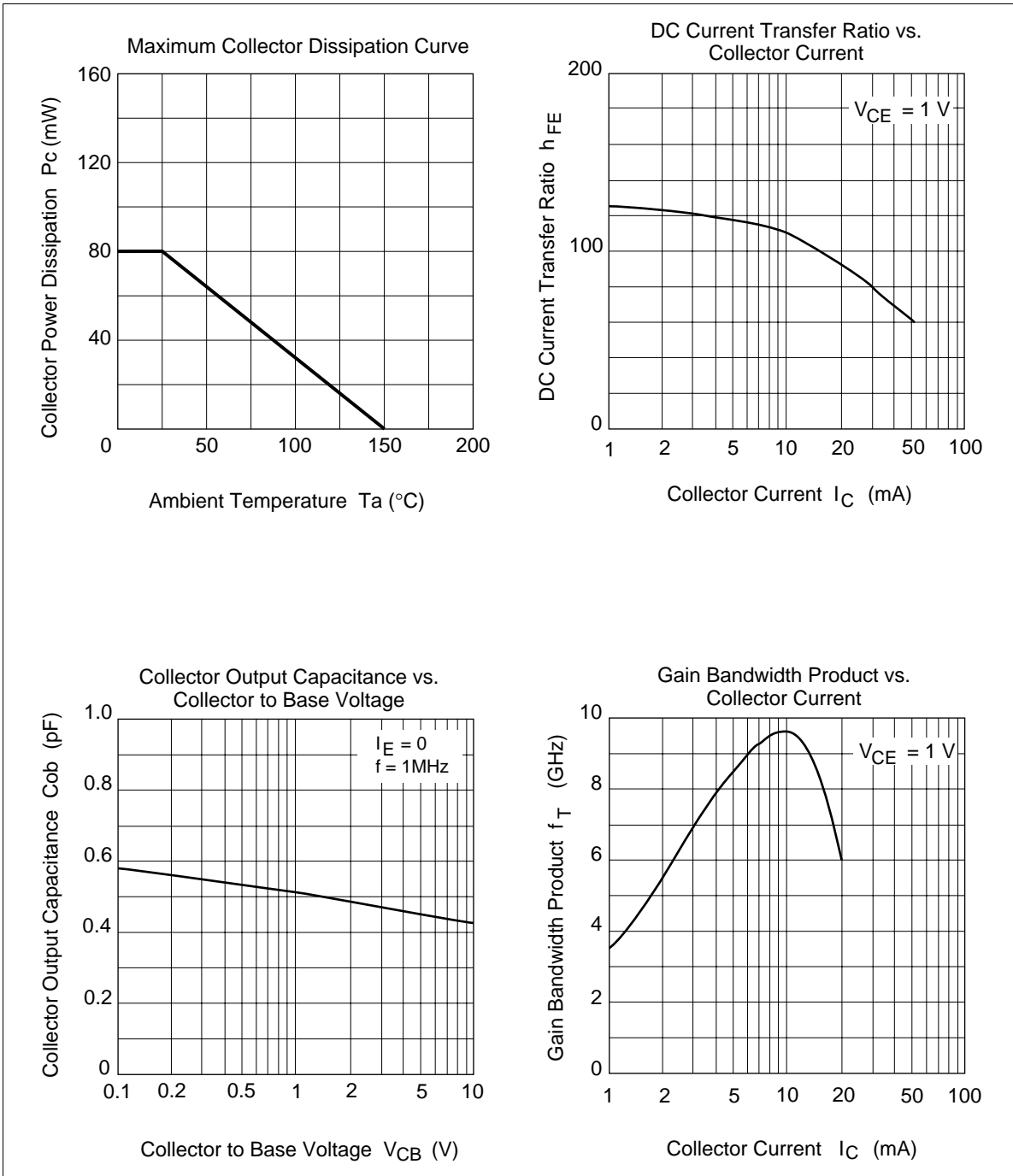

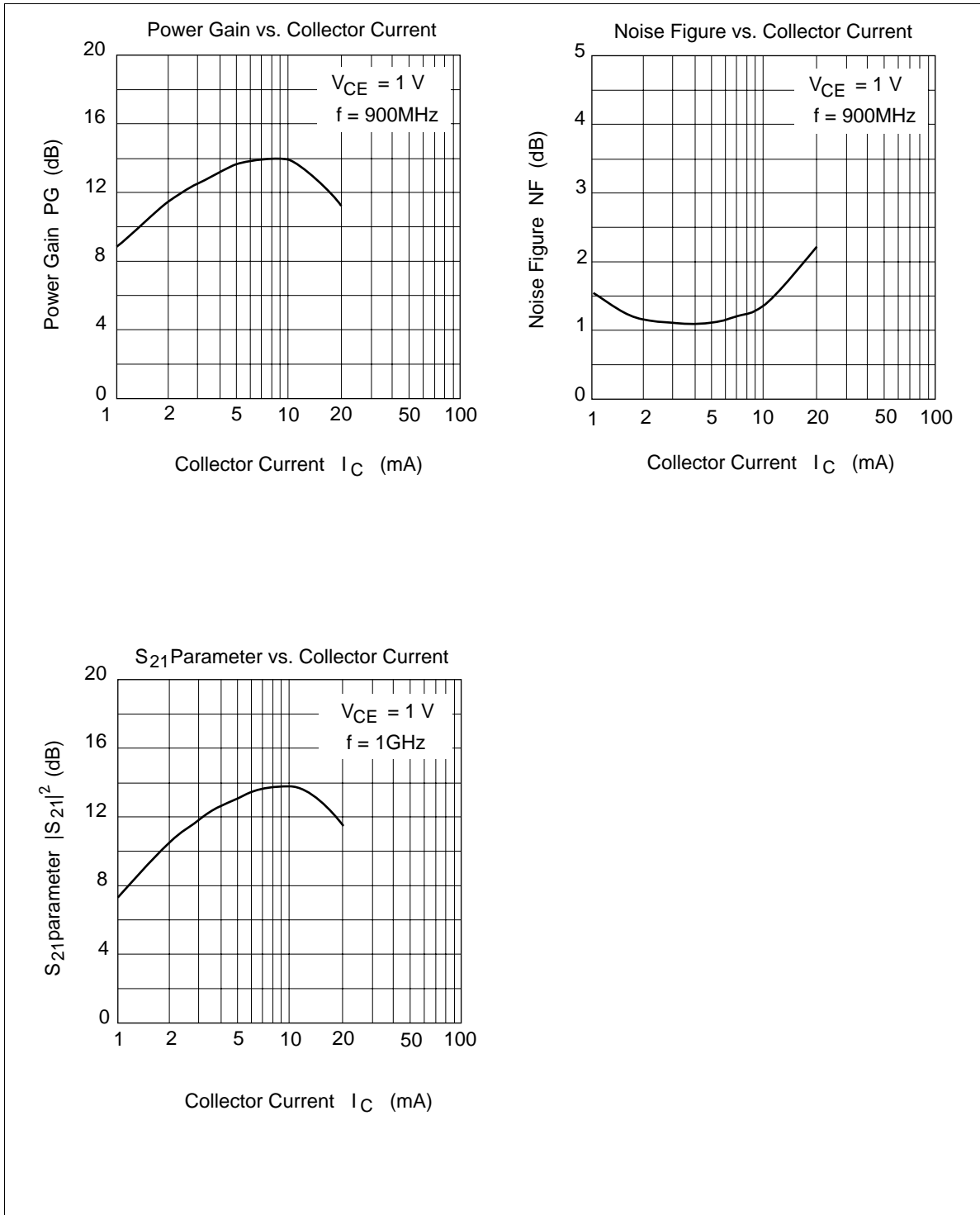

S11 Parameter vs. Frequency

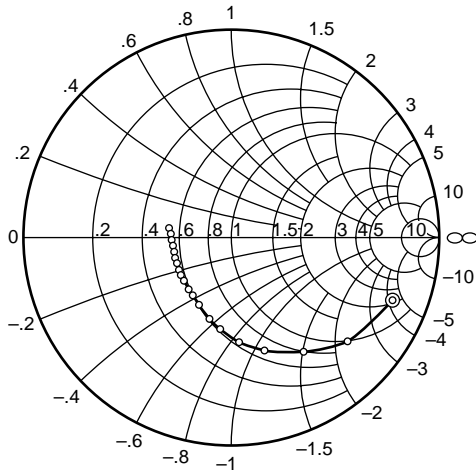

Condition : $V_{CE} = 1\text{ V}$, $I_C = 5\text{ mA}$

100 to 2000 MHz (100 MHz step)

⊙—○

S21 Parameter vs. Frequency

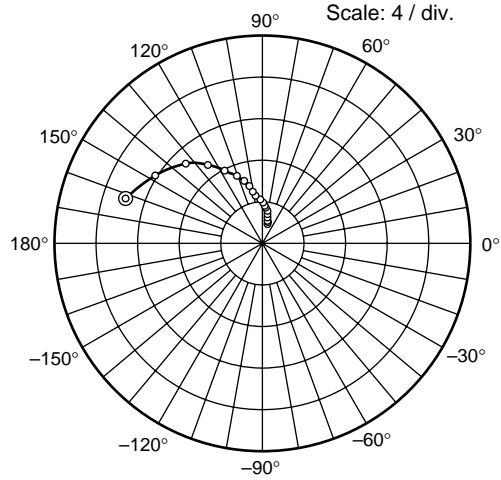

Condition : $V_{CE} = 1\text{ V}$, $I_C = 5\text{ mA}$

100 to 2000 MHz (100 MHz step)

⊙—○

S12 Parameter vs. Frequency

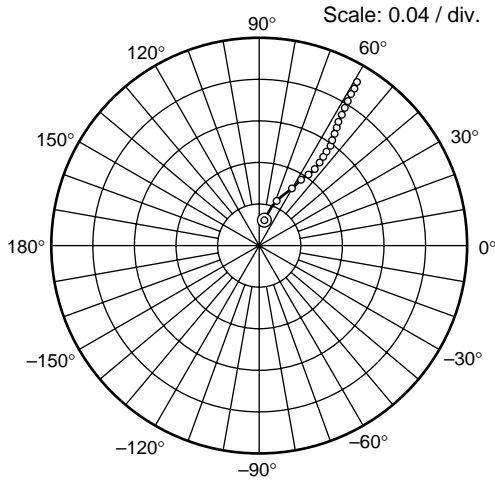

Condition : $V_{CE} = 1\text{ V}$, $I_C = 5\text{ mA}$

100 to 2000 MHz (100 MHz step)

⊙—○

S22 Parameter vs. Frequency

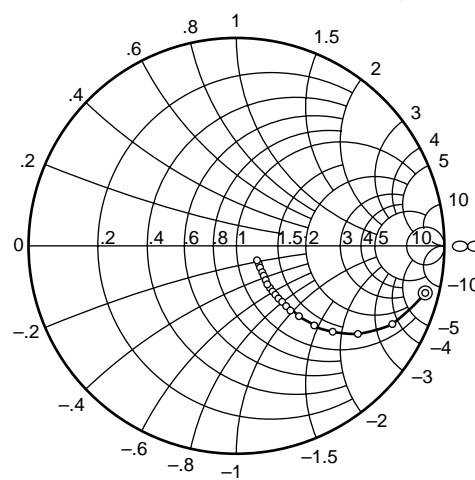

Condition : $V_{CE} = 1\text{ V}$, $I_C = 5\text{ mA}$

100 to 2000 MHz (100 MHz step)

⊙—○

2SC5543

Sparameter ($V_{CE} = 1V$, $I_C = 5mA$, $Z_o = 50\Omega$)

f (MHz)	S11		S21		S12		S22	
	MAG	ANG	MAG	ANG	MAG	ANG	MAG	ANG
100	0.836	-20.7	13.66	162.9	0.0249	77.4	0.948	-14.2
200	0.757	-41.1	12.22	146.9	0.0472	68.0	0.846	-26.9
300	0.649	-58.5	10.57	134.1	0.0637	60.8	0.727	-36.2
400	0.564	-73.2	9.14	124.5	0.0750	56.9	0.623	-42.5
500	0.496	-85.2	7.90	116.8	0.0840	54.2	0.538	-46.2
600	0.436	-97.1	6.91	111.2	0.0916	53.4	0.469	-48.8
700	0.396	-106.2	6.12	105.9	0.0985	53.0	0.413	-50.4
800	0.364	-114.9	5.49	102.0	0.105	53.2	0.368	-51.1
900	0.338	-123.9	4.96	98.3	0.111	53.6	0.327	-51.1
1000	0.316	-130.6	4.52	95.3	0.118	54.1	0.297	-51.2
1100	0.305	-140.0	4.16	92.3	0.124	54.7	0.270	-50.7
1200	0.296	-146.5	3.86	89.8	0.130	55.3	0.246	-49.7
1300	0.293	-153.0	3.59	87.5	0.137	56.1	0.229	-48.7
1400	0.286	-159.5	3.36	85.4	0.143	56.6	0.209	-47.9
1500	0.287	-166.0	3.17	83.2	0.150	57.2	0.195	-46.3
1600	0.285	-170.7	3.00	81.4	0.157	57.7	0.180	-45.0
1700	0.289	-175.8	2.83	79.8	0.164	58.2	0.167	-43.8
1800	0.294	-178.7	2.71	77.9	0.171	58.8	0.154	-42.4
1900	0.302	-175.4	2.59	75.9	0.178	59.0	0.144	-40.2
2000	0.308	-171.1	2.47	74.5	0.185	59.2	0.133	-38.6

Package Dimensions

Unit: mm

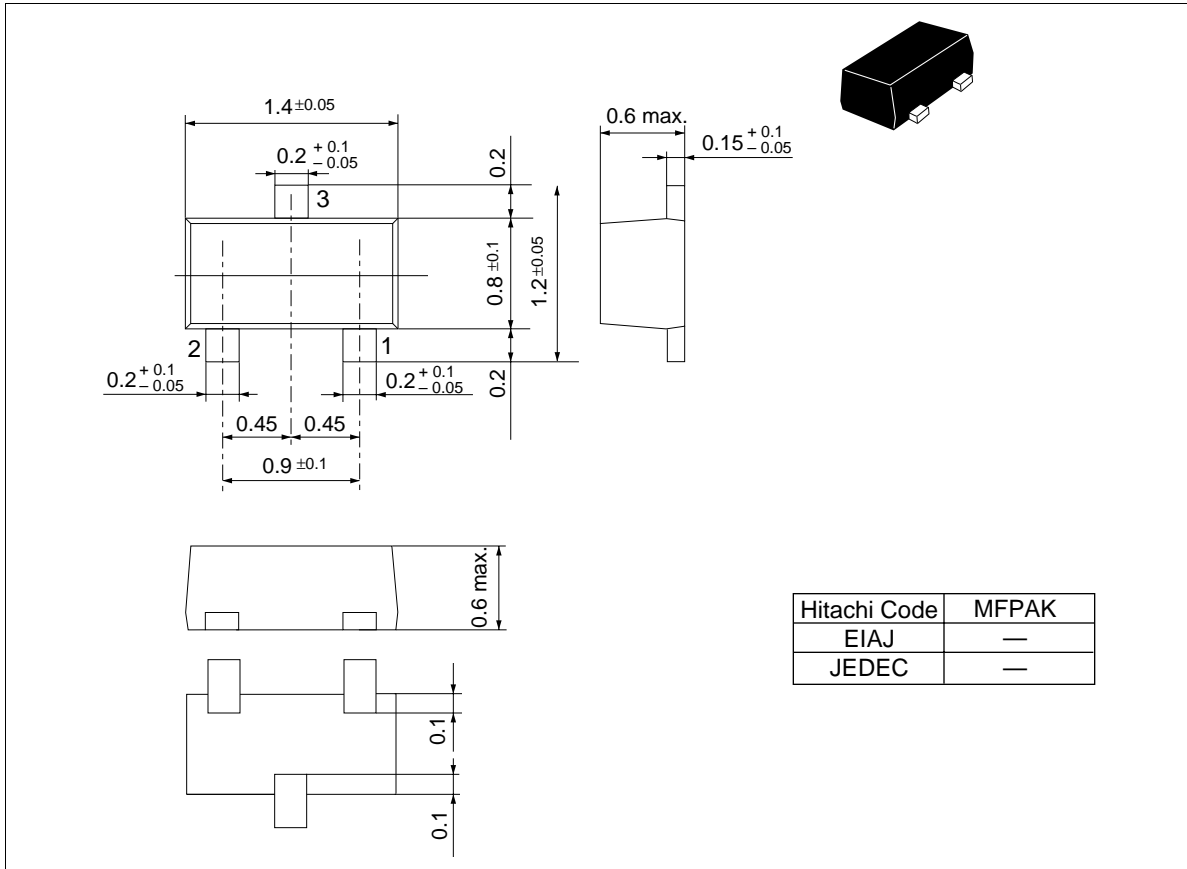

Cautions

1. Hitachi neither warrants nor grants licenses of any rights of Hitachi's or any third party's patent, copyright, trademark, or other intellectual property rights for information contained in this document. Hitachi bears no responsibility for problems that may arise with third party's rights, including intellectual property rights, in connection with use of the information contained in this document.
2. Products and product specifications may be subject to change without notice. Confirm that you have received the latest product standards or specifications before final design, purchase or use.
3. Hitachi makes every attempt to ensure that its products are of high quality and reliability. However, contact Hitachi's sales office before using the product in an application that demands especially high quality and reliability or where its failure or malfunction may directly threaten human life or cause risk of bodily injury, such as aerospace, aeronautics, nuclear power, combustion control, transportation, traffic, safety equipment or medical equipment for life support.
4. Design your application so that the product is used within the ranges guaranteed by Hitachi particularly for maximum rating, operating supply voltage range, heat radiation characteristics, installation conditions and other characteristics. Hitachi bears no responsibility for failure or damage when used beyond the guaranteed ranges. Even within the guaranteed ranges, consider normally foreseeable failure rates or failure modes in semiconductor devices and employ systemic measures such as fail-safes, so that the equipment incorporating Hitachi product does not cause bodily injury, fire or other consequential damage due to operation of the Hitachi product.
5. This product is not designed to be radiation resistant.
6. No one is permitted to reproduce or duplicate, in any form, the whole or part of this document without written approval from Hitachi.
7. Contact Hitachi's sales office for any questions regarding this document or Hitachi semiconductor products.

HITACHI

Hitachi, Ltd.

Semiconductor & Integrated Circuits.

Nippon Bldg., 2-6-2, Ohte-machi, Chiyoda-ku, Tokyo 100-0004, Japan
Tel: Tokyo (03) 3270-2111 Fax: (03) 3270-5109

URL North America : <http://semiconductor.hitachi.com/>
 Europe : <http://www.hitachi-eu.com/hel/ecg>
 Asia (Singapore) : <http://www.has.hitachi.com.sg/grp3/sicd/index.htm>
 Asia (Taiwan) : http://www.hitachi.com.tw/E/Product/SICD_Frame.htm
 Asia (HongKong) : <http://www.hitachi.com.hk/eng/bo/grp3/index.htm>
 Japan : <http://www.hitachi.co.jp/Sicd/indx.htm>

For further information write to:

Hitachi Semiconductor
(America) Inc.
179 East Tasman Drive,
San Jose, CA 95134
Tel: <1> (408) 433-1990
Fax: <1> (408) 433-0223

Hitachi Europe GmbH
Electronic components Group
Dornacher StraÙe 3
D-85622 Feldkirchen, Munich
Germany
Tel: <49> (89) 9 9180-0
Fax: <49> (89) 9 29 30 00

Hitachi Europe Ltd.
Electronic Components Group.
Whitebrook Park
Lower Cookham Road
Maidenhead
Berkshire SL6 8YA, United Kingdom
Tel: <44> (1628) 585000
Fax: <44> (1628) 778322

Hitachi Asia Pte. Ltd.
16 Collyer Quay #20-00
Hitachi Tower
Singapore 049318
Tel: 535-2100
Fax: 535-1533

Hitachi Asia Ltd.
Taipei Branch Office
3F, Hung Kuo Building, No.167,
Tun-Hwa North Road, Taipei (105)
Tel: <886> (2) 2718-3666
Fax: <886> (2) 2718-8180

Hitachi Asia (Hong Kong) Ltd.
Group III (Electronic Components)
7/F., North Tower, World Finance Centre,
Harbour City, Canton Road, Tsim Sha Tsui,
Kowloon, Hong Kong
Tel: <852> (2) 735 9218
Fax: <852> (2) 730 0281
Telex: 40815 HITEC HX

Copyright ' Hitachi, Ltd., 1999. All rights reserved. Printed in Japan.

HITACHI