

## Silicon PNP Power Transistors

2SA1217

## DESCRIPTION

- With TO-126 package
- Complement to type 2SC2877
- Good linearity of  $h_{FE}$

## APPLICATIONS

- Audio frequency power amplifier
- Low speed switching
- Suitable for output stage of 5 watts car radio and car stereo

## PINNING

PIN	DESCRIPTION
1	Emitter
2	Collector; connected to mounting base
3	Base

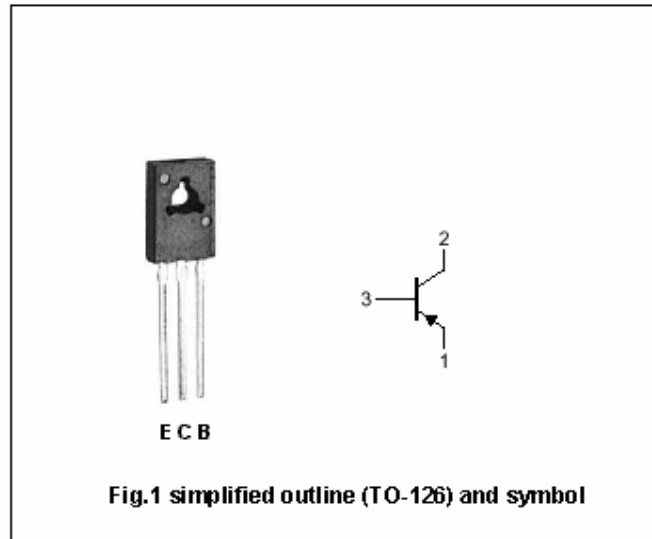
Absolute maximum ratings( $T_a=25^\circ\text{C}$ )

SYMBOL	PARAMETER	CONDITIONS	VALUE	UNIT
$V_{CBO}$	Collector-base voltage	Open emitter	-40	V
$V_{CEO}$	Collector-emitter voltage	Open base	-40	V
$V_{EBO}$	Emitter-base voltage	Open collector	-5	V
$I_C$	Collector current		-3	A
$I_B$	Base current		-1	A
$P_D$	Total power dissipation	$T_C=25^\circ\text{C}$	10	W
$T_j$	Junction temperature		150	$^\circ\text{C}$
$T_{stg}$	Storage temperature		-55~150	$^\circ\text{C}$

## Silicon PNP Power Transistors

## 2SA1217

## CHARACTERISTICS

T<sub>j</sub>=25°C unless otherwise specified

SYMBOL	PARAMETER	CONDITIONS	MIN	TYP.	MAX	UNIT
V <sub>(BR)CEO</sub>	Collector-emitter breakdown voltage	I <sub>C</sub> =-10mA ; I <sub>B</sub> =0	-40			V
V <sub>CEsat</sub>	Collector-emitter saturation voltage	I <sub>C</sub> =-2.0A ; I <sub>B</sub> =-0.2A			-0.8	V
V <sub>BE</sub>	Base-emitter on voltage	I <sub>C</sub> =-0.5A ; V <sub>CE</sub> =-2V			-1.0	V
I <sub>CBO</sub>	Collector cut-off current	V <sub>CB</sub> =-40V ; I <sub>E</sub> =0			-0.1	μ A
I <sub>EBO</sub>	Emitter cut-off current	V <sub>EB</sub> =-5V ; I <sub>C</sub> =0			-0.1	μ A
h <sub>FE-1</sub>	DC current gain	I <sub>C</sub> =-0.5A ; V <sub>CE</sub> =-2V	80		240	
h <sub>FE-2</sub>	DC current gain	I <sub>C</sub> =-2.5A ; V <sub>CE</sub> =-2V	25			
f <sub>T</sub>	Transition frequency	I <sub>C</sub> =-0.5A ; V <sub>CE</sub> =-2V		100		MHz
C <sub>OB</sub>	Collector output capacitance	f=1MHz ; V <sub>CB</sub> =-10V ; I <sub>E</sub> =0		35		pF

◆ h<sub>FE-1</sub> Classifications

O	Y
80-160	120-240

Silicon PNP Power Transistors

2SA1217

PACKAGE OUTLINE

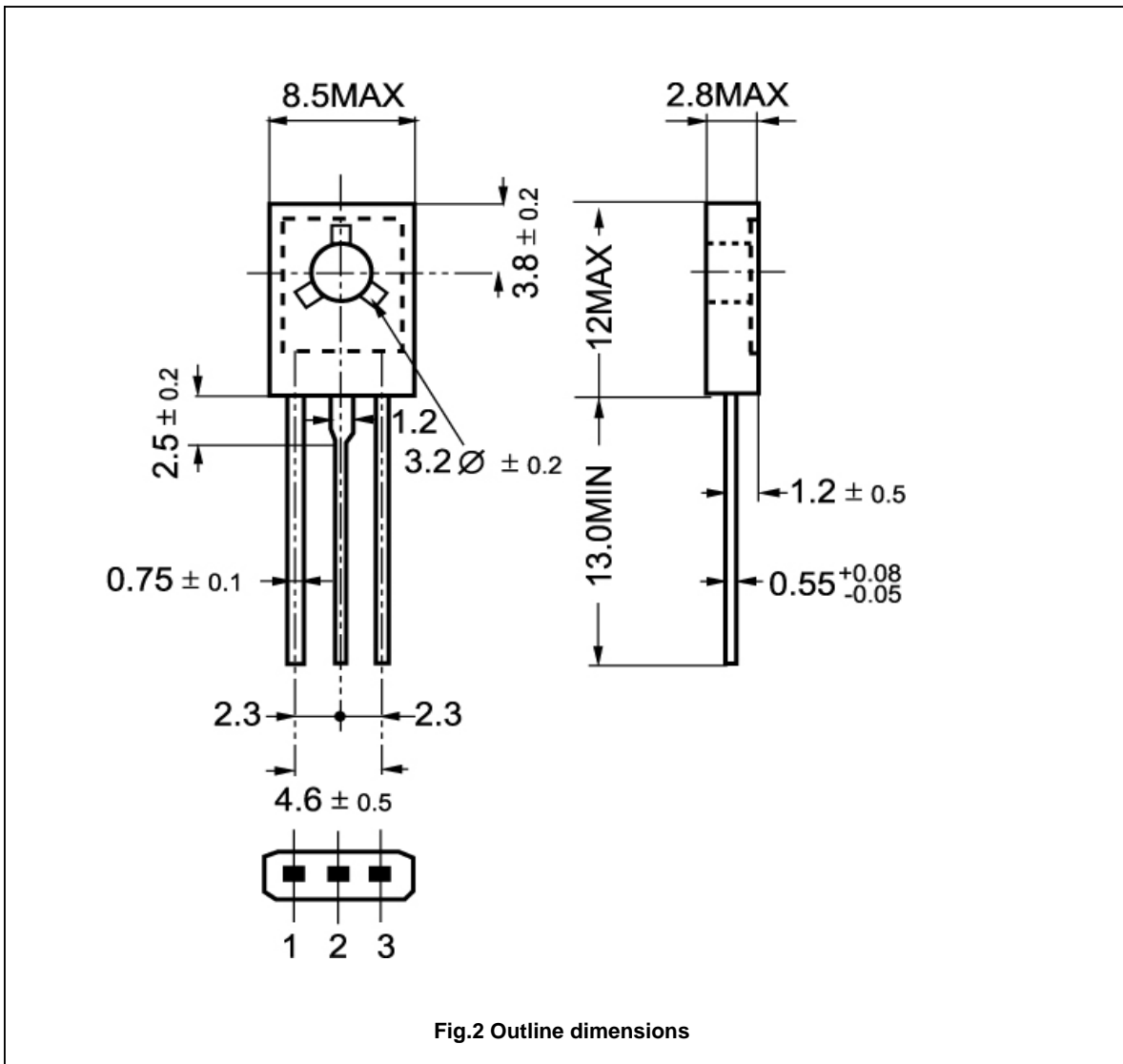

Silicon PNP Power Transistors

2SA1217

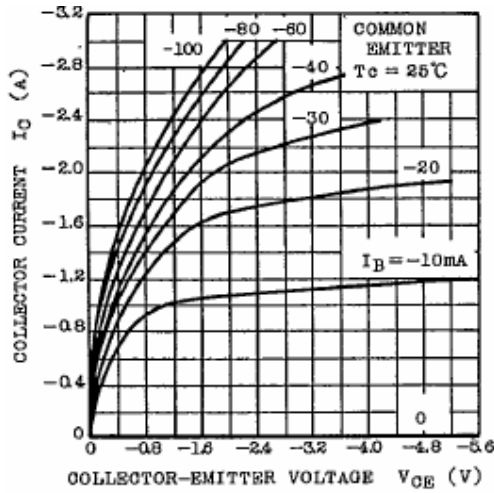

Fig.3 Static Characteristic

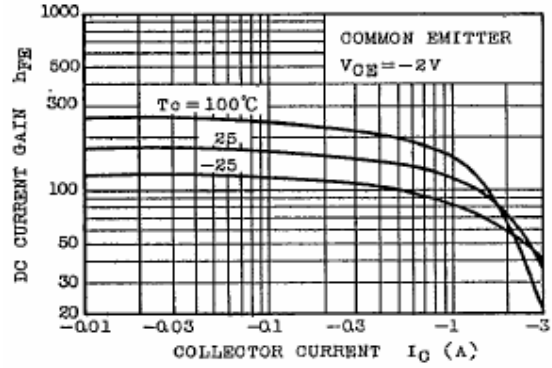

Fig.4 DC current Gain

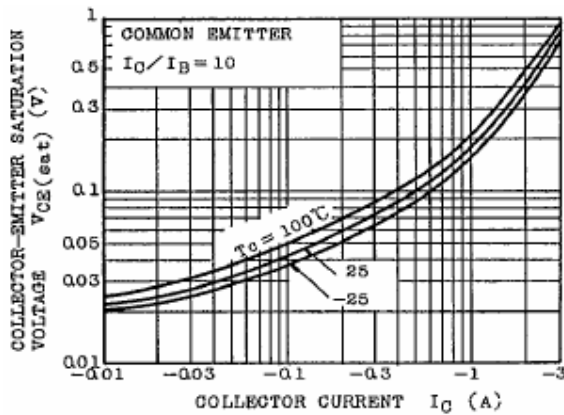

Fig.5 Collector-Emitter Saturation Voltage

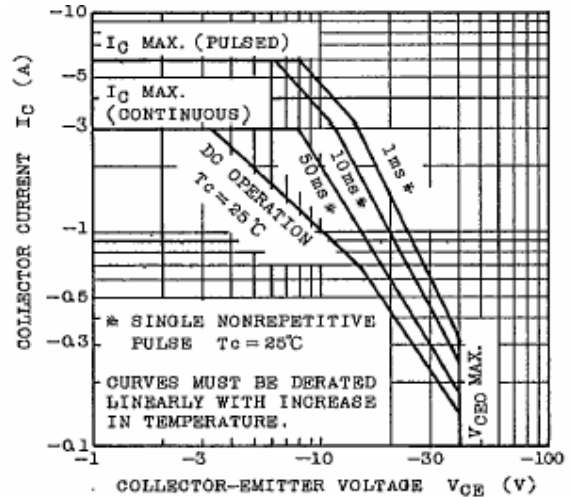

Fig.6 Safe Operating Area