

- Integral Visible Light Cutoff Filter
- Monolithic Silicon IC Containing Photodiode, Operational Amplifier, and Feedback Components
- Converts Light Intensity to Output Voltage
- High Irradiance Responsivity Typically $42 \text{ mV}/(\mu\text{W}/\text{cm}^2)$ at $\lambda_p = 940 \text{ nm}$ (TSL260)
- Low Dark (Offset) Voltage . . . 10 mV Max at 25°C , $V_{DD} = 5 \text{ V}$
- Single-Supply Operation
- Wide Supply Voltage Range . . . 3 V to 9 V
- Low Supply Current . . . 800 μA Typical at $V_{DD} = 5 \text{ V}$
- Advanced Linear CMOS Technology

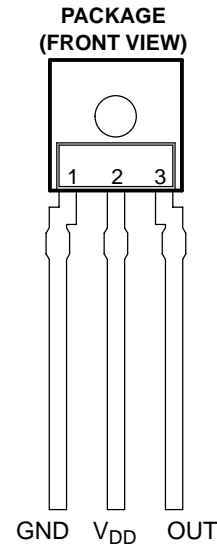

Description

The TSL260, TSL261, and TSL262 are light-to-voltage optical sensors, each combining a photodiode and a transimpedance amplifier (feedback resistor = 16 M Ω , 8 M Ω , and 2 M Ω , respectively) on a single monolithic integrated circuit. The output voltage is directly proportional to the infrared light intensity (irradiance) on the photodiode. The TSL260, TSL261, and TSL262 are manufactured using advanced linear CMOS silicon-gate technology, which provides good amplifier offset-voltage stability and low power consumption.

Functional Block Diagram

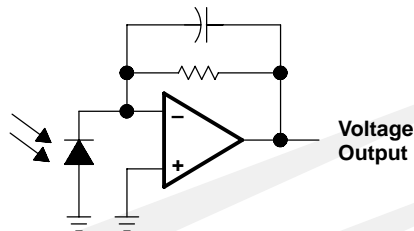

Terminal Functions

TERMINAL NAME	NO.	DESCRIPTION
GND	1	Ground (substrate). All voltages are referenced to GND.
OUT	3	Output voltage
V_{DD}	2	Supply voltage

TSL260, TSL261, TSL262 IR LIGHT-TO-VOLTAGE OPTICAL SENSORS

TAOS021 – MAY 2000

Absolute Maximum Ratings over operating free-air temperature range (unless otherwise noted)

Supply voltage, V_{DD} (see Note 1)	10 V
Output current, I_O	± 10 mA
Duration of short-circuit current at (or below) 25°C (see Note 2)	5 s
Operating free-air temperature range, T_A	-25°C to 85°C
Storage temperature range	-25°C to 85°C
Lead temperature 1,6 mm (1/16 inch) from case for 10 seconds	240°C

- NOTES: 1. All voltages are with respect to GND.
2. Output may be shorted to either supply.

Recommended Operating Conditions

	MIN	NOM	MAX	UNIT
Supply voltage, V_{DD}	3	5	9	V
Operating free-air temperature, T_A	0		70	°C

Electrical Characteristics at $V_{DD} = 5$ V, $T_A = 25^\circ\text{C}$, $\lambda_p = 940$ nm, $R_L = 10$ k Ω (unless otherwise noted) (see Note 3)

PARAMETER	TEST CONDITIONS	TSL260			TSL261			TSL262			UNIT
		MIN	TYP	MAX	MIN	TYP	MAX	MIN	TYP	MAX	
V_{DARK} Dark voltage	$E_e = 0$		3	10		3	10		3	10	mV
V_{OM} Maximum output	$E_e = 2.6$ mW/cm ²	3.1	3.5		3.1	3.5		3.1	3.5		V
V_O Output voltage	$E_e = 48$ $\mu\text{W}/\text{cm}^2$	1	2	3							V
	$E_e = 87$ $\mu\text{W}/\text{cm}^2$				1	2	3				
	$E_e = 525$ $\mu\text{W}/\text{cm}^2$							1	2	3	
Temperature coefficient of output voltage (V_O)	$E_e = 48$ $\mu\text{W}/\text{cm}^2$, $T_A = 0^\circ\text{C}$ to 70°C		± 1								mV/°C
	$E_e = 87$ $\mu\text{W}/\text{cm}^2$, $T_A = 0^\circ\text{C}$ to 70°C				± 1						
	$E_e = 525$ $\mu\text{W}/\text{cm}^2$, $T_A = 0^\circ\text{C}$ to 70°C							± 1			
N_e Irradiance responsivity	See Note 4		42			23			3.8		mV/($\mu\text{W}/\text{cm}^2$)
I_{DD} Supply current	$E_e = 48$ $\mu\text{W}/\text{cm}^2$, No load		900	1600							μA
	$E_e = 87$ $\mu\text{W}/\text{cm}^2$, No load					900	1600				
	$E_e = 525$ $\mu\text{W}/\text{cm}^2$, No load								900	1600	

- NOTES: 3. The input irradiance E_e is supplied by a GaAs infrared-emitting diode with $\lambda_p = 940$ nm.
4. Irradiance responsivity is characterized over the range $V_O = 0.05$ to 3 V.

Operating Characteristics at $T_A = 25^\circ\text{C}$ (see Figure 1)

PARAMETER	TEST CONDITIONS	TSL260			TSL261			TSL262			UNIT
		MIN	TYP	MAX	MIN	TYP	MAX	MIN	TYP	MAX	
t_r Output pulse rise time	$V_{DD} = 5$ V, $\lambda_p = 940$ nm		360			90			7		μs
t_f Output pulse fall time	$V_{DD} = 5$ V, $\lambda_p = 940$ nm		360			90			7		μs
V_n Output noise voltage	$V_{DD} = 5$ V, $f = 20$ Hz		0.6			0.5			0.4		$\mu\text{V}/\sqrt{\text{Hz}}$

PARAMETER MEASUREMENT INFORMATION

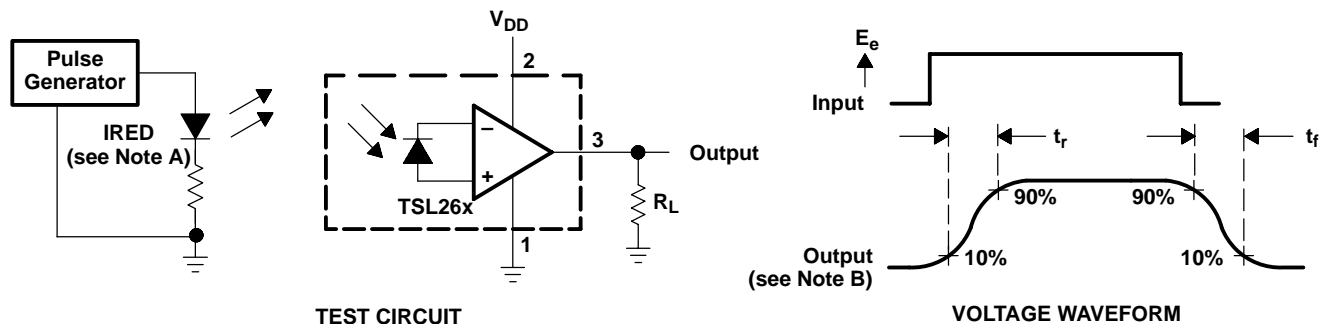

- NOTES: A. The input irradiance is supplied by a pulsed GaAs infrared-emitting diode with the following characteristics: $\lambda_p = 940 \text{ nm}$, $t_r < 1 \mu\text{s}$, $t_f < 1 \mu\text{s}$.
B. The output waveform is monitored on an oscilloscope with the following characteristics: $t_r < 100 \text{ ns}$, $Z_i \geq 1 \text{ MHz}$, $C_i \leq 20 \text{ pF}$.

Figure 1. Switching Times

TYPICAL CHARACTERISTICS

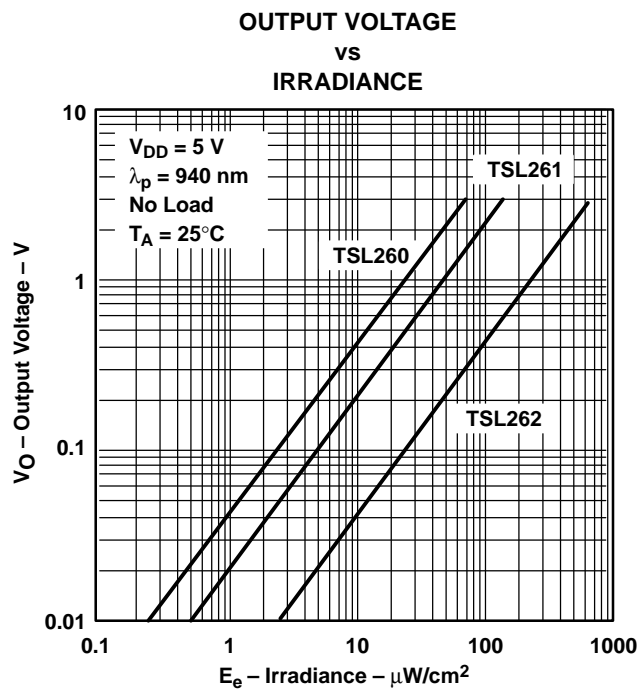

Figure 2

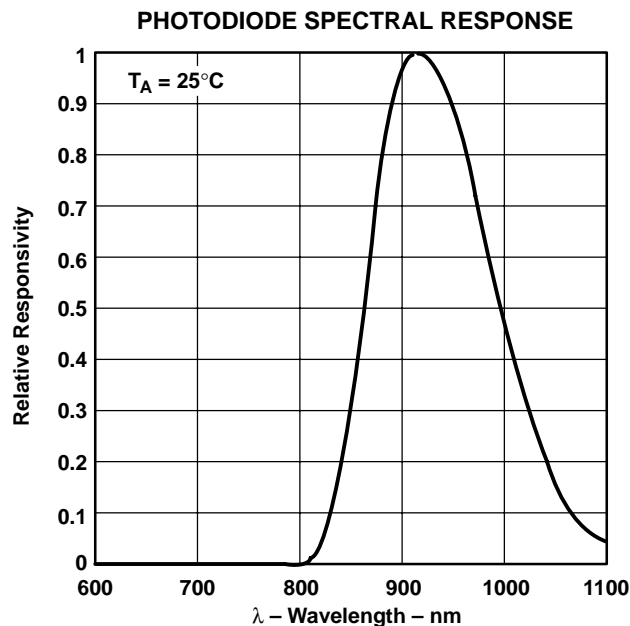

Figure 3

TSL260, TSL261, TSL262 IR LIGHT-TO-VOLTAGE OPTICAL SENSORS

TAOS021 – MAY 2000

TYPICAL CHARACTERISTICS

**HIGH-LEVEL OUTPUT VOLTAGE
vs
SUPPLY VOLTAGE**

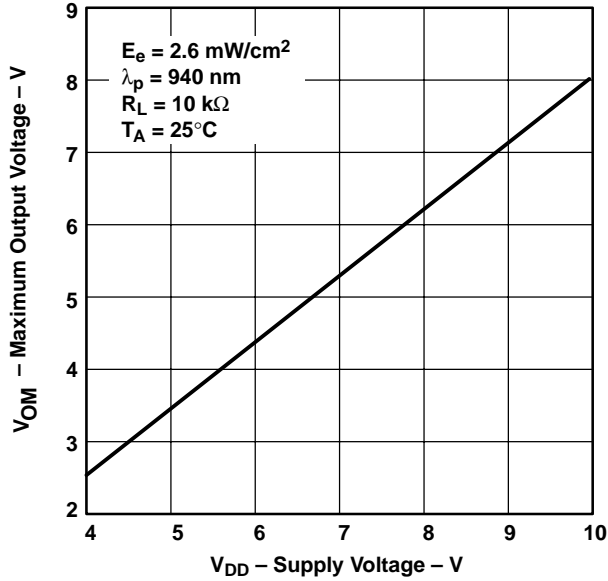

Figure 4

**SUPPLY CURRENT
vs
OUTPUT VOLTAGE**

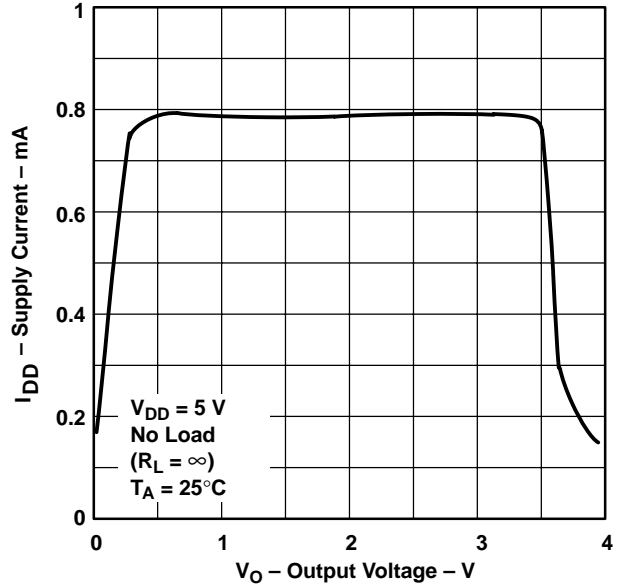

Figure 5

**NORMALIZED OUTPUT VOLTAGE
vs
ANGULAR DISPLACEMENT**

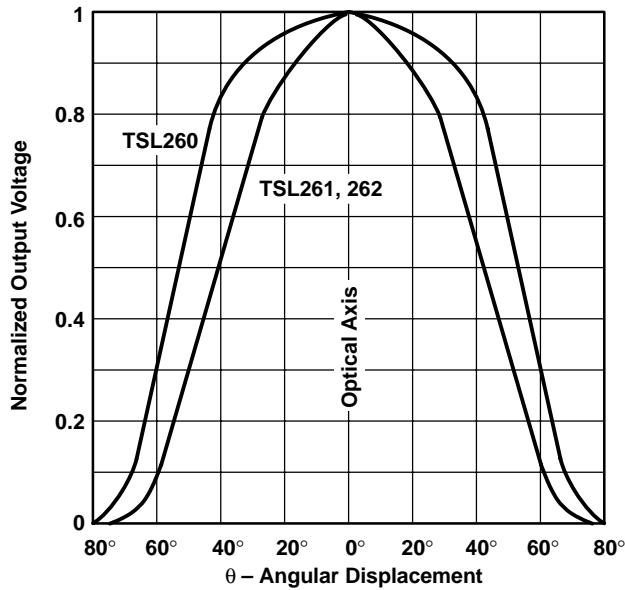
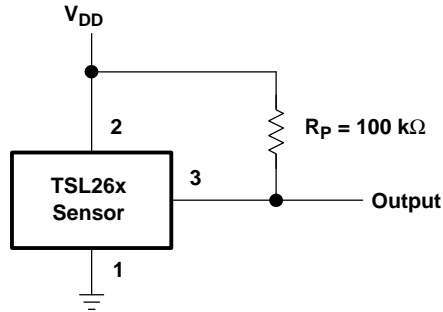

Figure 6



APPLICATION INFORMATION



NOTE A: Pullup resistor extends linear output range to near V_{DD} with minimal (several millivolts typical) effect on V_{DARK} ; particularly useful at low V_{DD} (3 V to 5 V).

Figure 7. Pullup for Increased V_{OM}

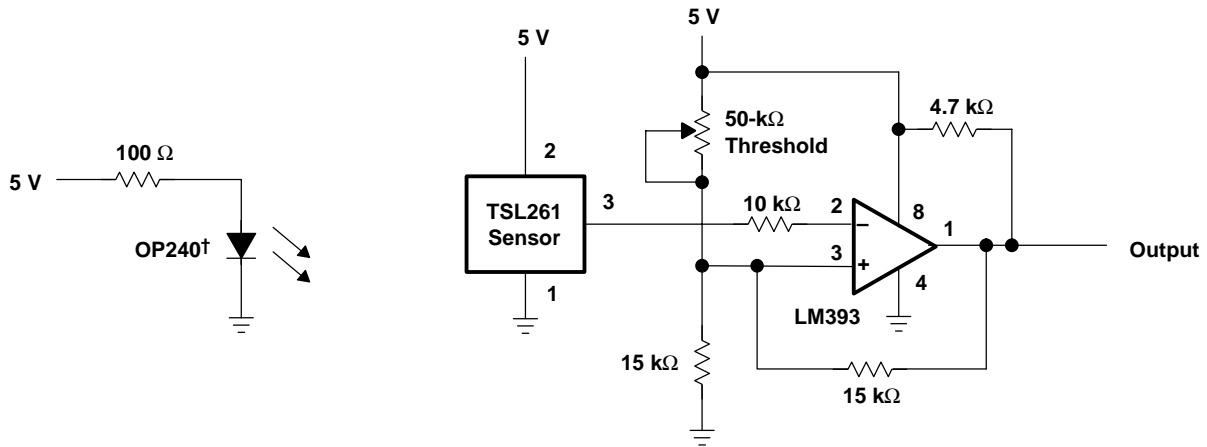

† OPTEK part number

NOTE A: Output goes high when beam is interrupted; working distance is several inches or less. Intended for use as optical-interrupter switch or reflective-object sensor.

Figure 8. Short-Range Optical Switch With Hysteresis

TSL260, TSL261, TSL262 IR LIGHT-TO-VOLTAGE OPTICAL SENSORS

TAOS021 – MAY 2000

APPLICATION INFORMATION

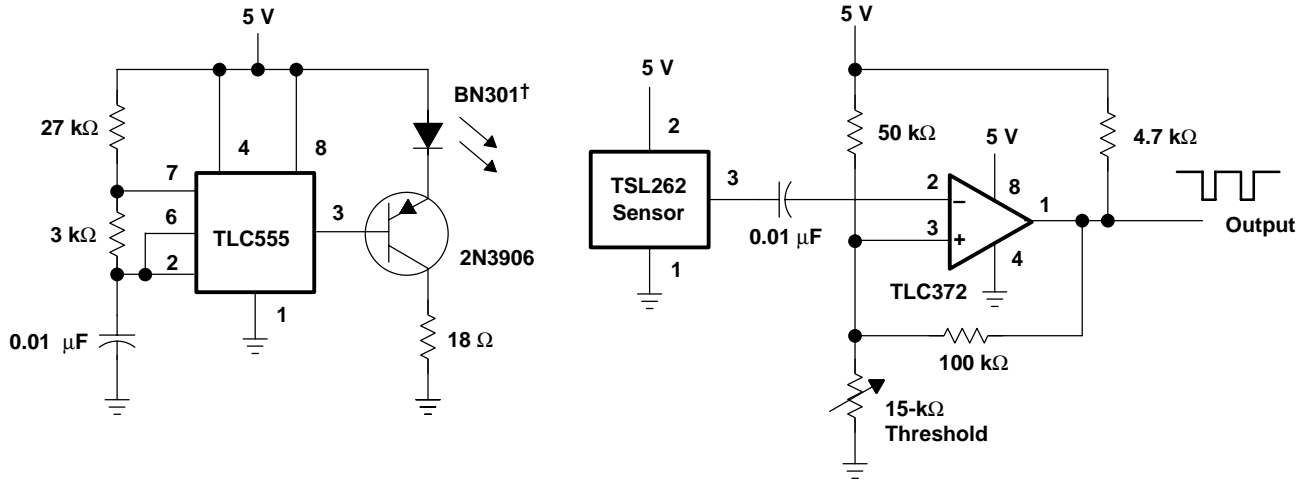

† Stanley part number

NOTE A: Output pulses low until beam is interrupted. Useful range is 1 ft to 20 ft; can be extended with lenses. This configuration is suited for object detection, safety guards, security systems, and automatic doors.

Figure 9. Pulsed Optical-Beam Interrupter

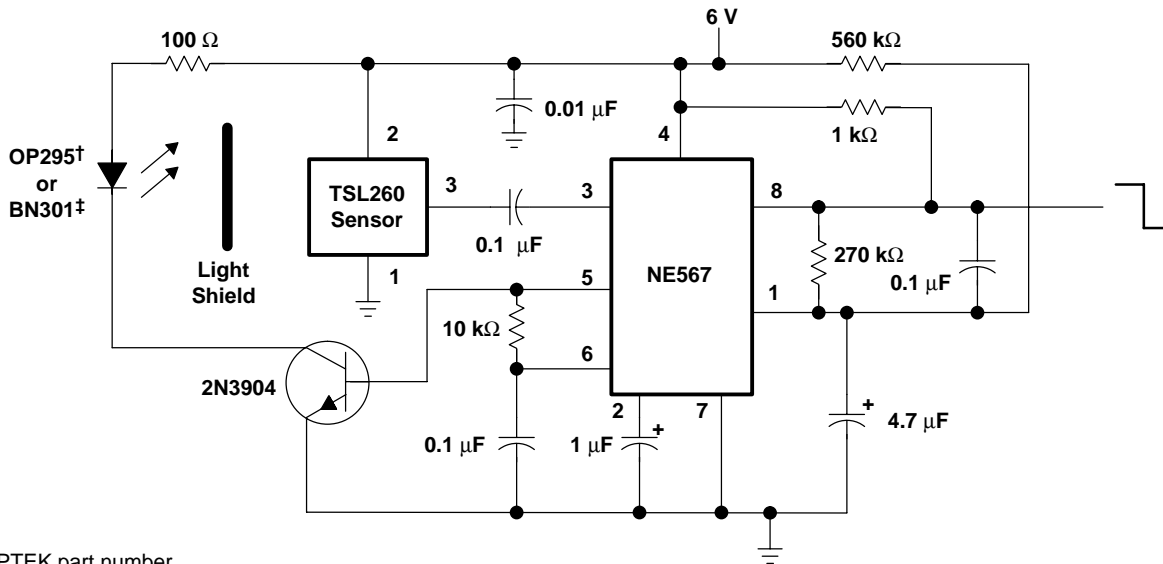

† OPTEK part number

‡ Stanley part number

NOTE A: Output goes low when light pulses from emitter are reflected back to sensor. Range is 6 in to 18 in depending upon object reflectance. Useful for automatic doors, annunciators, object avoidance in robotics, automatic faucets, and security systems.

Figure 10. Proximity Detector

APPLICATION INFORMATION

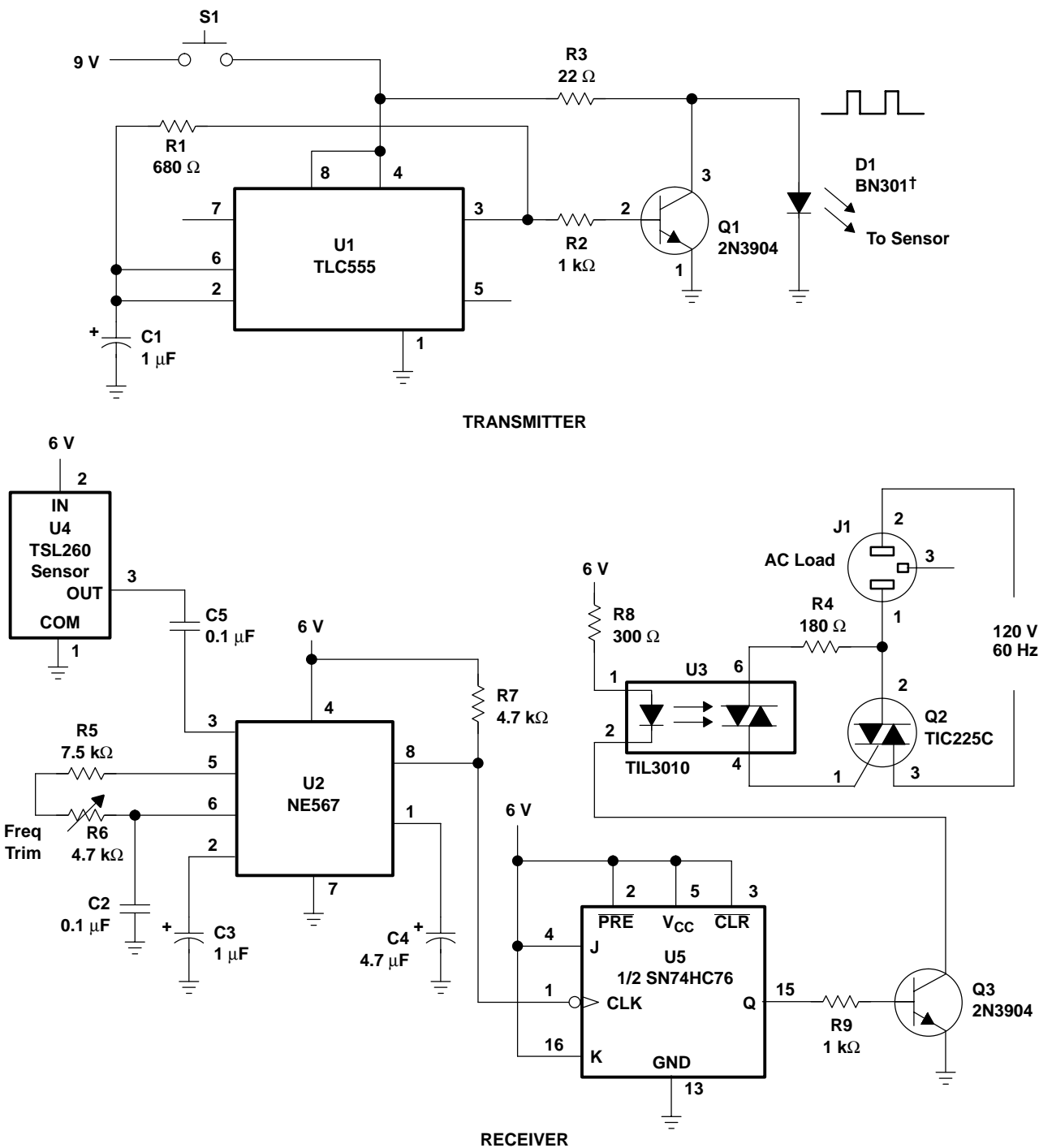

† OPTEK part number

NOTE A: Single-channel remote control can be used to switch logic or light dc loads by way of U5 or ac loads by way of the optocoupler and triac as shown. Applications include ceiling fans, lamps, electric heaters, etc.

Figure 11. IR Remote Control

TSL260, TSL261, TSL262 IR LIGHT-TO-VOLTAGE OPTICAL SENSORS

TAOS021 – MAY 2000

APPLICATION INFORMATION

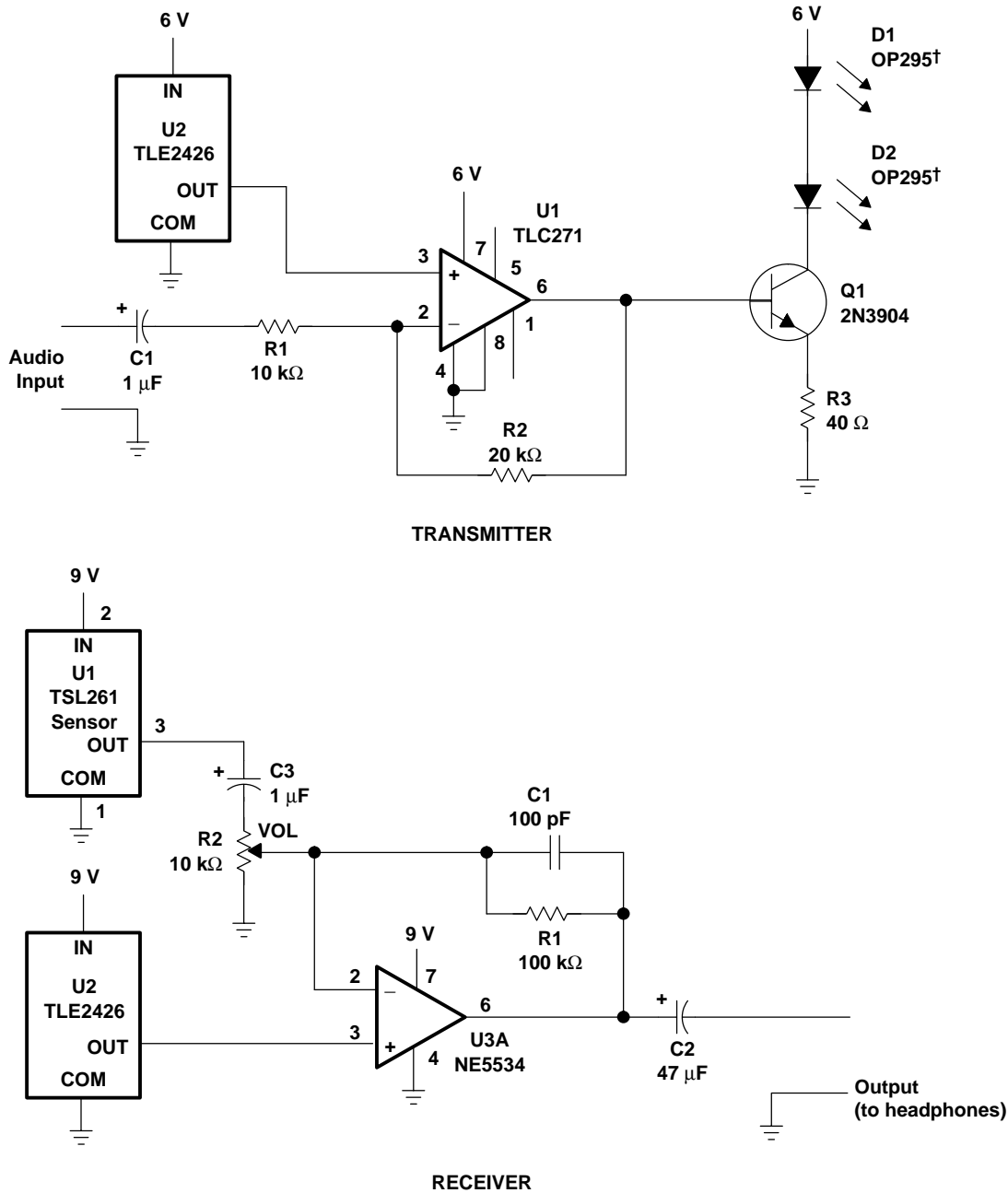

† OPTEK part number

NOTE A: Simple transmission of audio signal over short distances (<10 ft). Applications include wireless headphones, wireless-telephone headset, and wireless-headset intercom.

Figure 12. IR Voice-Band Audio Link

MECHANICAL DATA

The photodiode/amplifier chip is packaged in a black, infrared-transmissive plastic package. The integrated photodiode active area is typically 1.0 mm² (0.0016 in²), 0.5 mm² (0.00078 in²), and 0.26 mm² (0.0004 in²) for the TSL260, TSL261, and TSL262, respectively.

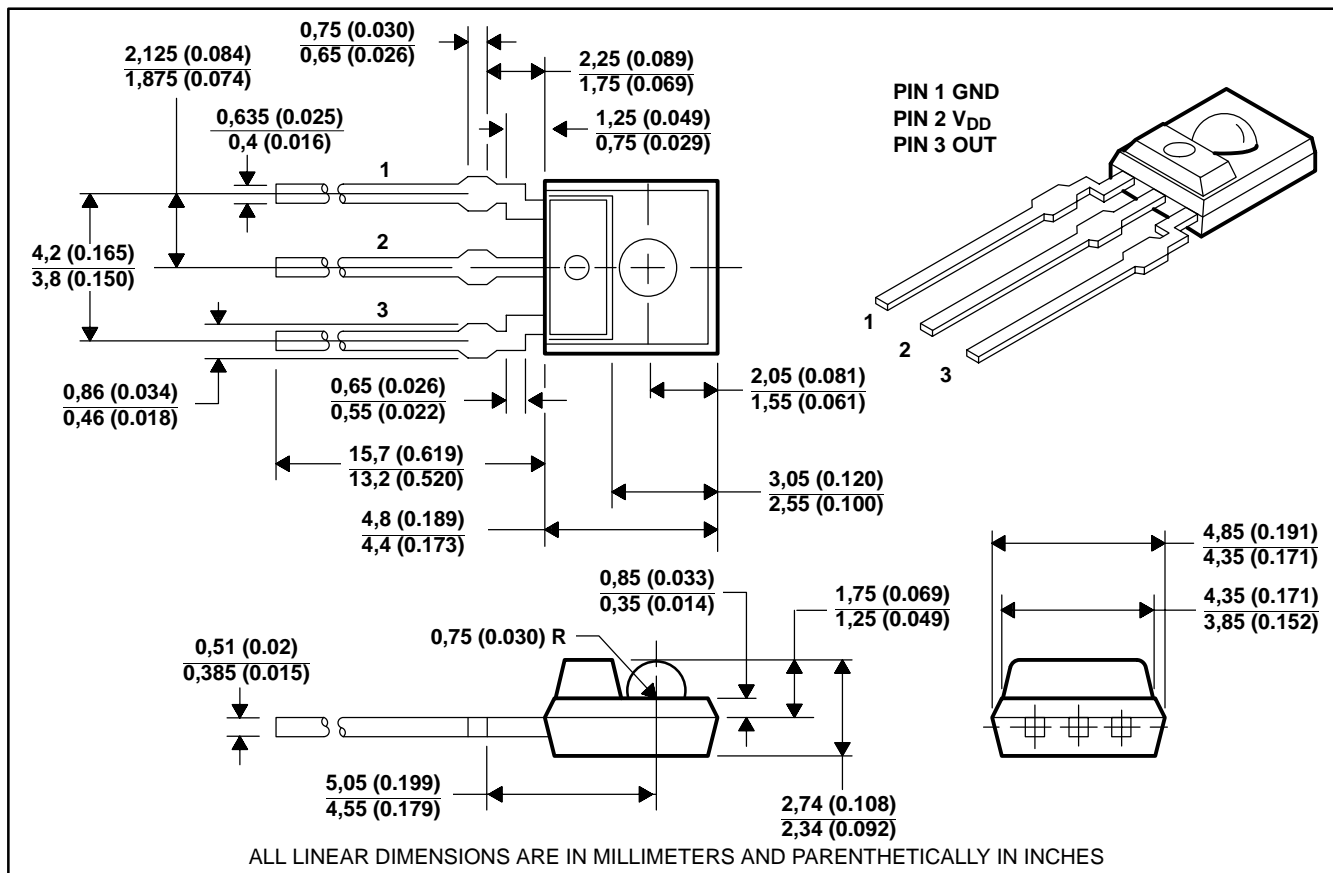

TSL260, TSL261, TSL262 IR LIGHT-TO-VOLTAGE OPTICAL SENSORS

TAOS021 – MAY 2000

PRODUCTION DATA — information in this document is current at publication date. Products conform to specifications in accordance with the terms of Texas Advanced Optoelectronic Solutions, Inc. standard warranty. Production processing does not necessarily include testing of all parameters.

NOTICE

Texas Advanced Optoelectronic Solutions, Inc. (TAOS) reserves the right to make changes to the products contained in this document to improve performance or for any other purpose, or to discontinue them without notice. Customers are advised to contact TAOS to obtain the latest product information before placing orders or designing TAOS products into systems.

TAOS assumes no responsibility for the use of any products or circuits described in this document or customer product design, conveys no license, either expressed or implied, under any patent or other right, and makes no representation that the circuits are free of patent infringement. TAOS further makes no claim as to the suitability of its products for any particular purpose, nor does TAOS assume any liability arising out of the use of any product or circuit, and specifically disclaims any and all liability, including without limitation consequential or incidental damages.

TEXAS ADVANCED OPTOELECTRONIC SOLUTIONS, INC. PRODUCTS ARE NOT DESIGNED OR INTENDED FOR USE IN CRITICAL APPLICATIONS IN WHICH THE FAILURE OR MALFUNCTION OF THE TAOS PRODUCT MAY RESULT IN PERSONAL INJURY OR DEATH. USE OF TAOS PRODUCTS IN LIFE SUPPORT SYSTEMS IS EXPRESSLY UNAUTHORIZED AND ANY SUCH USE BY A CUSTOMER IS COMPLETELY AT THE CUSTOMER'S RISK.

TAOS, the TAOS logo, and Texas Advanced Optoelectronic Solutions are trademarks of Texas Advanced Optoelectronic Solutions Incorporated.