

AC'97 Audio CODEC

DESCRIPTION

The WM9714L is a highly integrated input/output device designed for mobile computing and communications.

The chip is architected for dual CODEC operation, supporting Hi-Fi stereo Codec functions via the AC link interface, and additionally supporting voice Codec functions via a PCM type Synchronous Serial Port (SSP). A third Aux DAC is provided which may be used to support generation of supervisory tones, or ring-tones etc. at different sample rates to the main codec.

The device can connect directly to mono or stereo microphones, stereo headphones and a stereo speaker, reducing total component count in the system. Cap-less connections to the headphones, speakers, and earpiece may be used, saving cost and board area. Additionally, multiple analog input and output pins are provided for seamless integration with analog connected wireless communication devices.

All device functions are accessed and controlled through a single AC-Link interface compliant with the AC'97 standard. The 24.576 MHz masterclock can be input directly or generated internally from a 13MHz (or other frequency) clock by an onboard PLL. The PLL supports a wide range of input clock from 2.048MHz to 78.6Mhz.

The WM9714L operates at supply voltages from 1.8 to 3.6 Volts. Each section of the chip can be powered down under software control to save power. The device is available in a small leadless 7x7mm QFN package, ideal for use in handheld portable systems.

FEATURES

- AC'97 Rev 2.2 compatible stereo codec
 - DAC SNR 94dB, THD -85dB
 - ADC SNR 87dB, THD -86dB
 - Variable Rate Audio, supports all WinCE sample rates
 - Tone Control, Bass Boost and 3D Enhancement
- On-chip 45mW headphone driver
- On-chip 400mW mono or stereo speaker drivers
- Stereo, mono or differential microphone input
 - Automatic Level Control (ALC)
 - Mic insert and mic button press detection
- Auxiliary mono DAC (ring tone or DC level generation)
- Seamless interface to wireless chipset
- Additional PCM/I²S interface to support voice CODEC
- PLL derived audio clocks.
- Supports input clock ranging from 2.048Mhz to 78.6Mhz
- 1.8V to 3.6V supplies (digital down to 1.62V, speaker up to 4.2V)
- 7x7mm 48-pin QFN package

APPLICATIONS

- Personal Digital Assistants (PDA) with or without phone
- Smartphones
- Handheld and Tablet Computers

BLOCK DIAGRAM

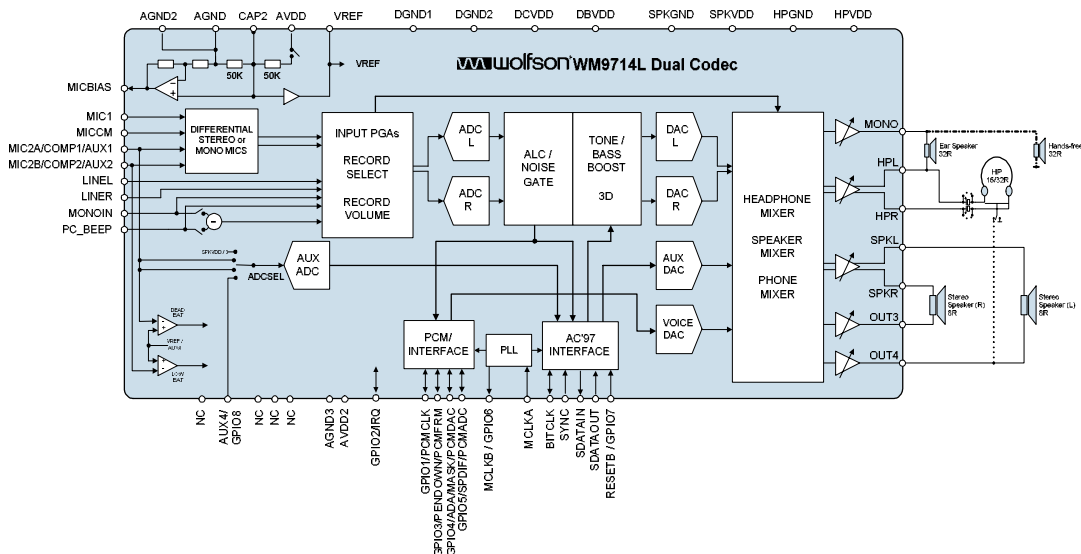
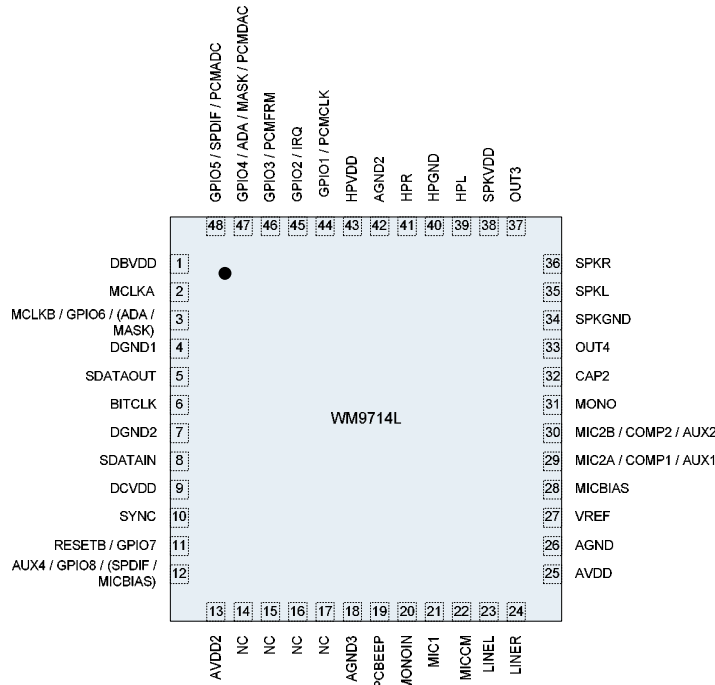

TABLE OF CONTENTS

DESCRIPTION	1
FEATURES.....	1
APPLICATIONS	1
BLOCK DIAGRAM	1
TABLE OF CONTENTS	2
PIN CONFIGURATION.....	4
ORDERING INFORMATION	4
PIN DESCRIPTION	5
ABSOLUTE MAXIMUM RATINGS.....	7
RECOMMENDED OPERATING CONDITIONS	7
ELECTRICAL CHARACTERISTICS	8
AUDIO OUTPUTS.....	8
AUDIO INPUTS.....	9
AUXILIARY MONO DAC (AUXDAC).....	9
PCM VOICE DAC (VXDAC).....	9
AUXILIARY ADC.....	10
COMPARATORS.....	10
REFERENCE VOLTAGES.....	10
DIGITAL INTERFACE CHARACTERISTICS.....	11
HEADPHONE / SPEAKER OUTPUT THD VERSUS POWER.....	12
POWER CONSUMPTION	13
DEVICE DESCRIPTION.....	14
INTRODUCTION.....	14
AUDIO PATHS OVERVIEW.....	16
CLOCK GENERATION	17
CLOCK DIVISION MODES	17
PLL MODE.....	20
DATA AND CONTROL INTERFACE.....	22
AC97 INTERFACE.....	22
PCM INTERFACE.....	23
AUDIO ADCS	28
STEREO ADC.....	28
RECORD SELECTOR	29
RECORD GAIN.....	30
AUTOMATIC LEVEL CONTROL.....	31
AUDIO DACS	35
STEREO DAC.....	35
VOICE DAC	37
AUXILIARY DAC.....	38
VARIABLE RATE AUDIO / SAMPLE RATE CONVERSION	40
AUDIO INPUTS	41
LINE INPUT	41
MICROPHONE INPUT	41
MONOIN INPUT.....	45
PCBEEP INPUT.....	46
DIFFERENTIAL MONO INPUT	47
AUDIO MIXERS.....	48
MIXER OVERVIEW	48

HEADPHONE MIXERS	48
SPEAKER MIXER	48
MONO MIXER.....	49
MIXER OUTPUT INVERTERS.....	49
ANALOGUE AUDIO OUTPUTS	50
HEADPHONE OUTPUTS – HPL AND HPR.....	50
MONO OUTPUT	51
SPEAKER OUTPUTS – SPKL AND SPKR	52
AUXILLARY OUTPUTS – OUT3 AND OUT4	53
THERMAL SENSOR.....	54
JACK INSERTION AND AUTO-SWITCHING.....	54
DIGITAL AUDIO (SPDIF) OUTPUT.....	58
AUX ADC.....	59
ADDITIONAL FEATURES.....	66
AUXILIARY ADC INPUTS	66
BATTERY ALARM AND ANALOGUE COMPARATORS.....	67
GPIO AND INTERRUPT CONTROL.....	70
POWER MANAGEMENT	74
INTRODUCTION.....	74
AC97 CONTROL REGISTER.....	74
EXTENDED POWERDOWN REGISTERS	74
ADDITIONAL POWER MANAGEMENT	75
POWER ON RESET (POR)	76
AC97 INTERFACE TIMING.....	76
REGISTER MAP.....	81
REGISTER BITS BY ADDRESS	82
APPLICATIONS INFORMATION	95
RECOMMENDED EXTERNAL COMPONENTS.....	95
LINE OUTPUT	95
AC-COUPLED HEADPHONE OUTPUT.....	96
DC COUPLED (CAPLESS) HEADPHONE OUTPUT	96
BTL LOUDSPEAKER OUTPUT	97
COMBINED HEADSET / BTL EAR SPEAKER.....	97
COMBINED HEADSET / SINGLE-ENDED EAR SPEAKER.....	98
JACK INSERT DETECTION	98
HOOKSWITCH DETECTION.....	98
TYPICAL OUTPUT CONFIGURATIONS	99
PACKAGE DIMENSIONS	102
IMPORTANT NOTICE	103
ADDRESS:.....	103

PIN CONFIGURATION



ORDERING INFORMATION

DEVICE	TEMPERATURE RANGE	PACKAGE	MOISTURE SENSITIVITY LEVEL	PEAK SOLDERING TEMPERATURE
WM9714LGEFL/V	-25 to +85°C	48-pin QFN (lead free)	MSL3	260°C
WM9714LGEFL/RV	-25 to +85°C	48-pin QFN (lead free, tape and reel)	MSL3	260°C

Note:

Reel quantity = 2,200

PIN DESCRIPTION

PIN	NAME	TYPE	DESCRIPTION
1	DBVDD	Supply	Digital I/O Buffer Supply
2	MCLKA	Digital Input	Master Clock A Input
3	MCLKB / GPIO6 / (ADA / MASK)	Digital In/Out	Master Clock B Input / GPIO6 / (ADA output / MASK input)
4	DGND1	Supply	Digital Ground (return path for both DCVDD and DBVDD)
5	SDATAOUT	Digital Input	Serial Data Output from Controller / Input to WM9714L
6	BITCLK	Digital Output	Serial Interface Clock Output to Controller
7	DGND2	Supply	Digital Ground (return path for both DCVDD and DBVDD)
8	SDATAIN	Digital Output	Serial Data Input to Controller / Output from WM9714L
9	DCVDD	Supply	Digital Core Supply
10	SYNC	Digital Input	Serial Interface Synchronisation Pulse from Controller
11	RESETB / GPIO7	Digital In / Out	Reset (asynchronous, active Low, resets all registers to their default) / GPIO7
12	AUX4 / GPIO8 / (SPDIF)	Analogue In / Out	Auxiliary ADC input / GPIO8 / (SPDIF digital audio output)
13	AVDD2	Supply	Analogue Supply
14	NC	Analogue Input	Do not connect
15	NC	Analogue Input	Do not connect
16	NC	Analogue Input	Do not connect
17	NC	Analogue Input	Do not connect
18	AGND3	Supply	Analogue Ground
19	PCBEEP	Analogue Input	Line Input to analogue audio mixers, typically used for beeps
20	MONOIN	Analogue Input	Mono Input (RX)
21	MIC1	Analogue Input	Microphone preamp A input 1
22	MICCM	Analogue Input	Microphone common mode input
23	LINEL	Analogue Input	Left Line Input
24	LINER	Analogue Input	Right Line Input
25	AVDD	Supply	Analogue Supply (audio DACs, ADCs, PGAs, mic amps, mixers)
26	AGND	Supply	Analogue Ground
27	VREF	Analogue Output	Internal Reference Voltage (buffered CAP2)
28	MICBIAS	Analogue Output	Bias Voltage for Microphones (buffered CAP2 × 1.8)
29	MIC2A / COMP1 / AUX1	Analogue Input	Microphone preamp A input 2 / COMP1 input / Auxillary ADC input
30	MIC2B / COMP2 / AUX2	Analogue Input	Microphone preamp B input / COMP2 input / Auxillary ADC input
31	MONO	Analogue output	Mono output driver (line or headphone)
32	CAP2	Analogue In / Out	Internal Reference Voltage (normally AVDD/2, if not overdriven)
33	OUT4	Analogue Output	Auxillary output driver (speaker, line or headphone)
34	SPKGND	Supply	Speaker ground (feeds output buffers on pins 33, 35, 36 and 37)
35	SPKL	Analogue Output	Left speaker driver (speaker, line or headphone)
36	SPKR	Analogue Output	Right speaker driver (speaker, line or headphone)
37	OUT3	Analogue Output	Auxillary output driver (speaker, line or headphone)
38	SPKVDD	Supply	Speaker supply (feeds output buffers on pins 33, 35, 36 and 37)
39	HPL	Analogue Output	Headphone left driver (line or headphone)
40	HPGND	Supply	Headphone ground (feeds output buffers on pins 39 and 41)
41	HPR	Analogue Output	Headphone right driver (line or headphone)
42	AGND2	Supply	Analogue ground, chip substrate
43	HPVDD	Supply	Headphone supply (feeds output buffers on pins 39 and 41)

WM9714L

Preliminary Technical Data

PIN	NAME	TYPE	DESCRIPTION
44	GPIO1 / PCMCLK	Digital In / Out	GPIO Pin 1 or PCM interface clock
45	GPIO2 / IRQ	Digital In / Out	GPIO Pin 2 or IRQ (Interrupt Request) output
46	GPIO3 / PCMF5	Digital In / Out	GPIO Pin 3 or PCM frame signal
47	GPIO4 / ADA / MASK / PCMDAC	Digital In / Out	GPIO Pin 4 or ADA (ADC data available) output or Mask input or PCM input (DAC) data
48	GPIO5 / SPDIF / PCMADC	Digital In / Out	GPIO Pin 5 or SPDIF digital audio output or PCM output (ADC) data

ABSOLUTE MAXIMUM RATINGS

Absolute Maximum Ratings are stress ratings only. Permanent damage to the device may be caused by continuously operating at or beyond these limits. Device functional operating limits and guaranteed performance specifications are given under Electrical Characteristics at the test conditions specified.



ESD Sensitive Device. This device is manufactured on a CMOS process. It is therefore generically susceptible to damage from excessive static voltages. Proper ESD precautions must be taken during handling and storage of this device.

Wolfson tests its package types according to IPC/JEDEC J-STD-020B for Moisture Sensitivity to determine acceptable storage conditions prior to surface mount assembly. These levels are:

MSL1 = unlimited floor life at <30°C / 85% Relative Humidity. Not normally stored in moisture barrier bag.

MSL2 = out of bag storage for 1 year at <30°C / 60% Relative Humidity. Supplied in moisture barrier bag.

MSL3 = out of bag storage for 168 hours at <30°C / 60% Relative Humidity. Supplied in moisture barrier bag.

The Moisture Sensitivity Level for each package type is specified in Ordering Information.

CONDITION	MIN	MAX
Digital supply voltages (DCVDD, DBVDD)	-0.3V	+3.63V
Analogue supply voltages (AVDD, HPVDD)	-0.3V	+3.63V
Speaker supply voltage (SPKVDD)	-0.3V	+4.2V
Voltage range digital inputs	DGND -0.3V	DBVDD +0.3V
Voltage range analogue inputs	AGND -0.3V	AVDD +0.3V
Operating temperature range, T _A	-25°C	+85°C
Storage temperature (TQFP package only)	-65°C	+150°C

RECOMMENDED OPERATING CONDITIONS

PARAMETER	SYMBOL	TEST CONDITIONS	MIN	TYP	MAX	UNIT
Digital input/output buffer supply range	DBVDD		1.62 (target)	3.3	3.6	V
Digital core supply range	DCVDD		1.62 (target)	1.8	3.6	V
Analogue supply range	AVDD, HPVDD		1.8	3.3	3.6	V
Speaker supply range	SPKVDD		1.8	3.3	4.2	V
Digital ground	DGND1, DGND2			0		V
Analogue ground	AGND, HPGND, SPKGND			0		V
Difference AGND to DGND		Note 1	-0.3	0	+0.3	V

Note:

1. AGND is normally the same as DGND1/DGND2
2. DCVDD <= DBVDD and DCVDD <= AVDD

ELECTRICAL CHARACTERISTICS

AUDIO OUTPUTS

Test Conditions

DBVDD=3.3V, DCVDD = 3.3V, AVDD=HPVDD=SPKVDD =3.3V, T_A = +25°C, 1kHz signal, f_s = 48kHz, 24-bit audio data unless otherwise stated.

PARAMETER	SYMBOL	TEST CONDITIONS	MIN	TYP	MAX	UNIT
DAC to Line-Out (HPL/R or MONO with 10kΩ / 50pF load)						
Full-scale output		AVDD = 3.3V, PGA gains set to 0dB		1		V rms
Signal to Noise Ratio (A-weighted)	SNR		85	94		dB
Total Harmonic Distortion	THD	-3dB output		-85	-74	dB
Power Supply Rejection	PSRR	100mV, 20Hz to 20kHz signal on AVDD		50		dB
Speaker Output (SPKL/SPKR with 8Ω bridge tied load, INV=1)						
Output Power at 1% THD	P _O	THD = 1%		400		mW (rms)
Abs. max output power	P _{Omax}			500		mW (rms)
Total Harmonic Distortion	THD	P _O = 200mW		-66 0.05		dB %
Signal to Noise Ratio (A-weighted)	SNR			90		dB
Stereo Speaker Output (SPKL/OUT4 and SPKR/OUT3 with 8Ω bridge tied load, INV=1)						
Output Power at 1% THD	P _O	THD = 1%		400		mW (rms)
Abs. max output power	P _{Omax}			500		mW (rms)
Total Harmonic Distortion	THD	P _O = 200mW		-66 0.05		dB %
Signal to Noise Ratio (A-weighted)	SNR			90		dB
Headphone Output (HPL/R, OUT3/4 or SPKL/SPKR with 16Ω or 32Ω load)						
Output Power per channel	P _O	Output power is very closely correlated with THD; see below.				
Total Harmonic Distortion	THD	P _O =10mW, R _L =16Ω		-80		dB
		P _O =10mW, R _L =32Ω		-80		
		P _O =20mW, R _L =16Ω		-78		
		P _O =20mW, R _L =32Ω		-79		
Signal to Noise Ratio (A-weighted)	SNR			90		dB

Note:

- All THD values are valid for the output power level quoted above – for example, at HPVDD=3.3V and R_L=16Ω, THD is -80dB when output power is 10mW. Higher output power is possible, but will result in a deterioration in THD.

AUDIO INPUTS**Test Conditions**

DBVDD=3.3V, DCVDD = 3.3V, AVDD = 3.3V, T_A = +25°C, 1kHz signal, fs = 48kHz, 24-bit audio data unless otherwise stated.

PARAMETER	SYMBOL	TEST CONDITIONS	MIN	TYP	MAX	UNIT
LINEL/R, MIC1/2A/2B and MONOIN pins						
Full Scale Input Signal Level (for ADC 0dB Input at 0dB Gain)	V _{INFS}	AVDD = 3.3V		1.0		V _{rms}
		AVDD = 1.8V		0.545		
		differential input mode (MS = 01)	half of the value listed above			
Input Resistance	R _{IN}	0dB PGA gain	25.6	32	38.4	kΩ
		12dB PGA gain	10.4	13	15.6	
Input Capacitance				5		pF
Line input to ADC (LINEL, LINER, MONOIN)						
Signal to Noise Ratio (A-weighted)	SNR		80	87		dB
Total Harmonic Distortion	THD			-86	-80	dB
Power Supply Rejection	PSRR	20Hz to 20kHz		50		dB
Microphone input to ADC (MIC1/2A/2B pins)						
Signal to Noise Ratio (A-weighted)	SNR	20dB boost enabled		80		dB
Total Harmonic Distortion	THD	20dB boost enabled		-80		dB
Power Supply Rejection Ratio	PSRR			50		dB
Common Mode Rejection Ratio	CMRR	Differential mic mode		TBD		dB

AUXILIARY MONO DAC (AUXDAC)**Test Conditions**

AVDD = 3.3V, T_A = +25°C, unless otherwise stated.

PARAMETER	SYMBOL	TEST CONDITIONS	MIN	TYP	MAX	UNIT
Resolution				12		bits
Full scale output voltage		AVDD=3.3V		1		V _{rms}
Signal to Noise Ratio (A-weighted)	SNR			TBD		dB
Total Harmonic Distortion	THD			TBD		dB

PCM VOICE DAC (VXDAC)**Test Conditions**

AVDD = 3.3V, T_A = +25°C, unless otherwise stated.

PARAMETER	SYMBOL	TEST CONDITIONS	MIN	TYP	MAX	UNIT
Resolution				16		bits
Sample rates				8	16	Ks/s
Full scale output voltage		AVDD=3.3V		1		V _{rms}
Signal to Noise Ratio (A-weighted)	SNR			80		dB
Total Harmonic Distortion	THD			74		dB

AUXILIARY ADC**Test Conditions**

DBVDD=3.3V, DCVDD = 3.3V, AVDD = 3.3V, T_A = +25°C, MCLK = 24.576 MHz, unless otherwise stated.

PARAMETER	SYMBOL	TEST CONDITIONS	MIN	TYP	MAX	UNIT
Input Pins AUX4, COMP1/AUX1, COMP2/AUX2						
Input Voltage			AGND		AVDD	V
Input leakage current		AUX pin not selected as AUX ADC input		<10		nA
ADC Resolution				12		bits
Differential Non-Linearity Error	DNL			±0.25	±1	LSB
Integral Non-Linearity Error	INL				±2	LSB
Offset Error					±4	LSB
Gain Error					±6	LSB
Power Supply Rejection	PSRR			50		dB
Channel-to-channel isolation				80		dB
Throughput Rate		DEL = 1111 (zero settling time)			48	kHz
Settling Time (programmable)		MCLK = 24.576MHz	0		6	ms
Switch matrix resistance				20		Ω

COMPARATORS**Test Conditions**

AVDD = 3.3V, T_A = +25°C, unless otherwise stated.

PARAMETER	SYMBOL	TEST CONDITIONS	MIN	TYP	MAX	UNIT
COMP1/AUX1 and COMP2/AUX2 (pins 29, 30 – when not used as mic inputs)						
Input Voltage			AGND		AVDD	V
Input leakage current		pin not selected as AUX ADC input		<10		nA
Comparator Input Offset (COMP1, COMP2 only)			-50		+50	mV
COMP2 delay (COMP2 only)		MCLK = 24.576MHz	0		10.9	s

REFERENCE VOLTAGES**Test Conditions**

DBVDD=3.3V, DCVDD = 3.3V, AVDD = 3.3V, T_A = +25°C, 1kHz signal, f_s = 48kHz, 24-bit audio data unless otherwise stated.

PARAMETER	SYMBOL	TEST CONDITIONS	MIN	TYP	MAX	UNIT
Audio ADCs, DACs, Mixers						
Reference Input/Output	CAP2 pin		1.63	1.65	1.66	V
Buffered Reference Output	VREF pin		1.64	1.65	1.67	V
Microphone Bias						
Bias Voltage	V _{MICBIAS}		2.92	2.97	3.00	V
Bias Current Source	I _{MICBIAS}				3	mA
Output Noise Voltage	V _n	1K to 20kHz		15		nV/√Hz

DIGITAL INTERFACE CHARACTERISTICS**Test Conditions**DBVDD = 3.3V, DCVDD = 3.3V, T_A = +25°C, unless otherwise stated.

PARAMETER	SYMBOL	TEST CONDITIONS	MIN	TYP	MAX	UNIT
Digital Logic Levels (all digital input or output pins) – CMOS Levels						
Input HIGH level	V _{IH}		DBVDD×0.7			V
Input LOW level	V _{IL}				DBVDD×0.3	V
Output HIGH level	V _{OH}	source current = 2mA	DBVDD×0.9			
Output LOW level	V _{OL}	sink current = 2mA			DBVDD×0.1	
Clock Frequency						
Master clock (MCLKA pin)				24.576		MHz
AC'97 bit clock (BIT_CLK pin)				12.288		MHz
AC'97 sync pulse (SYNC pin)				48		kHz

Note:

1. All audio and non-audio sample rates and other timing scales proportionately with the master clock.
2. For signal timing on the AC-Link, please refer to the AC'97 specification (Revision 2.2)

HEADPHONE / SPEAKER OUTPUT THD VERSUS POWER

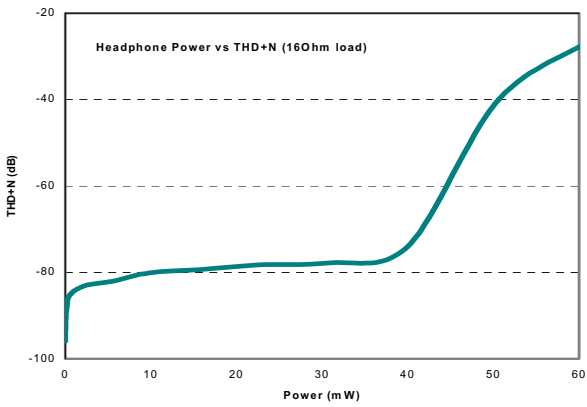
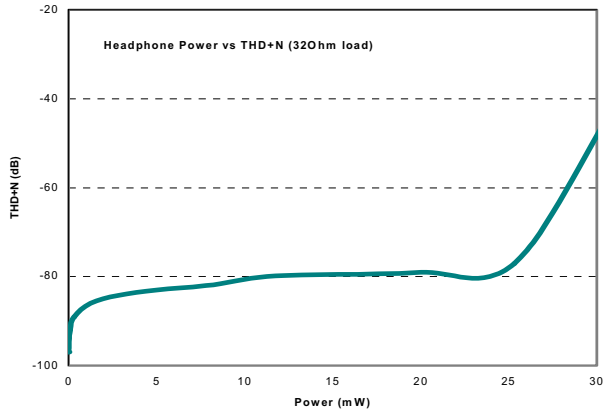

POWER CONSUMPTION

The power consumption of the WM9714L depends on the following factors:

- Supply voltages: Reducing the supply voltages also reduces digital supply currents, and therefore results in significant power savings especially in the digital sections of the WM9714L.
- Operating mode: Significant power savings can be achieved by always disabling parts of the WM9714L that are not used (e.g. audio ADC, DAC, touchpanel digitiser).
- Sample rates: Running at lower sample rates will reduce power consumption significantly. The figures below are for 48kHz (unless otherwise specified), but in many scenarios it is not necessary to run at this frequency, e.g. 8kHz PCM voice call scenario uses only 11.4mW (see below).

MODE DESCRIPTION	AVDD Supply Current V / mA		DCVDD Supply Current V / mA		DBVDD Supply Current V / mA		Total Power (mW)
Off (lowest possible power) Clocks stopped. This is the default configuration after power-up.	3.3	0.01	3.3	0	3.3	0.005	0.05
LPS (Low Power Standby) VREF maintained using 1M Ω string	3.3	0.014	3.3	0	3.3	0.005	0.06
PCM Voice call (fs=8kHz)	2.8	2.37	2.8	1.7	2.8	0.006	11.4
Record from mono microphone	3.3	3.644	3.3	10.973	3.3	2.974	58.05
Stereo DAC Playback (AC link to headphone)	3.3	3.733	3.3	9.720	3.3	2.789	53.60
Stereo DAC Playback (AC link to headphone) PLL running with 13MHz input to MCLKB	3.3	4.801	3.3	10.504	3.3	2.814	59.79
Maximum Power - everything on	3.3	13.656	3.3	15.472	3.3	2.938	105.82

Table 1 Supply Current Consumption

Notes:

1. Unless otherwise specified, all figures are at TA = +25C, audio sample rate fs = 48kHz, with zero signal (quiescent), and voltage references settled.
2. The power dissipated in the headphone, speaker and touchpanel is not included in the above table.

DEVICE DESCRIPTION

INTRODUCTION

The WM9714L is a largely pin compatible upgrade to WM9712, with a PCM voice codec added. This codec is interfaced via a PCM type audio interface which makes use of GPIO pins for connection.

It is designed to meet the mixed-signal requirements of portable and wireless smartphone systems. It includes audio recording and playback, battery monitoring, auxiliary ADC and GPIO functions, all controlled through a single 5-wire AC-Link interface. Additionally, PCM voice codec functions are supported through provision of an additional voice DAC and a PCM audio serial interface.

A PLL is included to allow unrelated reference clocks to be used for generation of the AC link system clock. Typically 13MHz or 2.048MHz references might be used as a reference.

SOFTWARE SUPPORT

The basic audio features of the WM9714L are software compatible with standard AC'97 device drivers. However, to better support additional functions, Wolfson Microelectronics supplies custom device drivers for selected CPUs and operating systems. Please contact your local Wolfson Sales Office for more information.

AC'97 COMPATIBILITY

The WM9714L uses an AC'97 interface to communicate with a microprocessor or controller. The audio and GPIO functions are largely compliant with AC'97 Revision 2.2. The following **differences** from the AC'97 standard are noted:

- Pinout: The function of some pins has been changed to support device specific features. The PHONE and PCBEEP pins have been moved to different locations on the device package.
- Package: The default package for the WM9714L is a 7x7mm leadless QFN package.
- Audio mixing: The WM9714L handles all the audio functions of a smartphone, including audio playback, voice recording, phone calls, phone call recording, ring tones, as well as simultaneous use of these features. The AC'97 mixer architecture does not fully support this. The WM9714L therefore uses a modified AC'97 mixer architecture with three separate mixers.
- Tone Control, Bass Boost and 3D Enhancement: These functions are implemented in the digital domain and therefore affect only signals being played through the audio DACs, not all output signals as stipulated in AC'97.

Some other functions are **additional** to AC'97:

- On-chip BTL loudspeaker driver for mono or stereo speakers
- On-chip BTL driver for ear speaker (phone receiver)
- Auxiliary mono DAC for ring tones, system alerts etc.
- Auxiliary ADC Inputs
- 2 Analogue Comparators for Battery Alarm
- Programmable Filter Characteristics for Tone Control and 3D Enhancement
- PCM interface to additional Voice DAC and existing audio ADCs
- PLL to create AC'97 system clock from unrelated reference clock input

PCM CODEC

The PCM voice codec functions typically required by mobile telephony devices are provided by an extra voice DAC on the WM9714L, which is interfaced via a standard PCM type data interface, which is constructed through optional use of 4 of the GPIO pins on WM9714L. The audio output data from one or both of the audio ADCs can also be output over this PCM interface, allowing a full voice codec function to be implemented. This codec supports sample rates from 8 to 48ks/s using the standard AC'97 masterclock, with the WM9714L PCM interface always acting as a master.

AUDIO PATHS OVERVIEW

WM9714 Analogue
Note: all PGAs and summers are inverting

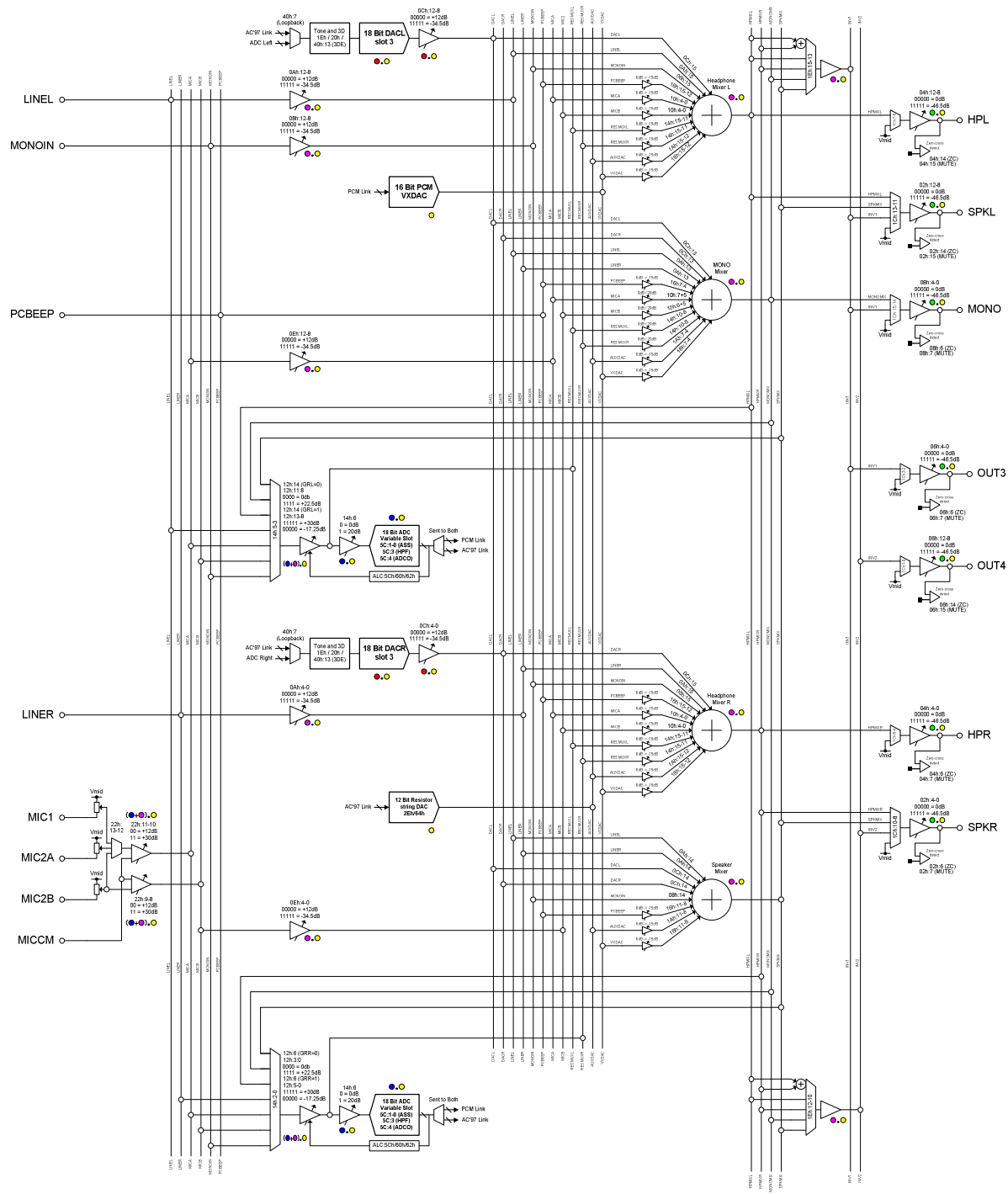

PR Bit Code

- PR0 - Audio ADCs & record mux
- PR1 - Stereo DAC
- PR2 - Input PGAs & mixers
- PR3 - Refs, input PGAs, mixers & output PGAs
- PR6 - Output PGAs

Note: PR bits are active low - i.e. 0 = "ON", 1 = "OFF"
 (●●●) ⇒ Enable when ((PR0 || PR2) && PR3) are low

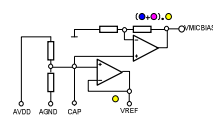

Figure 1 Audio Paths Overview

CLOCK GENERATION

WM9714L supports clocking from 2 separate sources, which can be selected via the AC'97 interface:

- External clock input MCLKA
- External clock input MCLKB

The source clock is divided to appropriate frequencies in order to run the AC'97 interface, PCM interface, voice DAC and Hi-fi DSP by means of a programmable divider block. Clock rates may be changed during operation via the AC'97 link in order support alternative modes, for example low power mode when voice data is being transmitted only. A PLL is present to add flexibility in selection of input clock frequencies, typical choices being 2.048MHz, 4.096MHz or 13MHz.

Default mode on power-up assumes a clock will be present on MCLKA with the PLL powered down. This enables data to be clocked via the AC'97 link to define the desired clock divider mode and whether PLL needs to be activated.

Note: This clock can be any available frequency.

When muxing between MCLKA and MCLKB both clocks must be active for at least two clock cycles after the switching event.

CLOCK DIVISION MODES

Figure 2 shows the clocking strategy for WM9714L. Clocking is controlled by CLK_MUX, CLK_SRC and S[6:0].

- CLKAX2, CLKBX2 – clock doublers on inputs MCLKA and MCLKB.
- CLK_MUX - selects between MCLKA and MCLKB.
- CLK_SRC – selects between external or PLL derived clock reference.
- S[3:0] – sets the voice DAC clock rate and PCM interface clock when in master mode (division ratio 1 to 16 available).
- S[6:4] - sets the hi-fi clocking rate (division ratio 1 to 8 available).

The registers used to set these switches can be accessed from register address 44h (see Table 2).

If a mode change requires switching from an external clock to a PLL generated clock then it is recommended to set the clock division ratios required for the PLL clock scheme prior to switching between clocks. This option is accommodated by means of two sets of registers S_{PLL}[6:0] and S_{EXT}[6:0]. If the PLL is selected (CLK_SRC = 0) S[6:0] = S_{PLL}[6:0], if an external clock is selected (CLK_SRC = 1) S[6:0] = S_{EXT}[6:0]. S_{EXT}[6:0] is defined in register address 44h. S_{PLL}[6:0] is defined in register 46h (see Table 4) which also contains a number of separate control bits relating to the PLL's function.

Writing to registers 44h and 46h enables pre-programming of the required clock mode before the PLL output is selected.

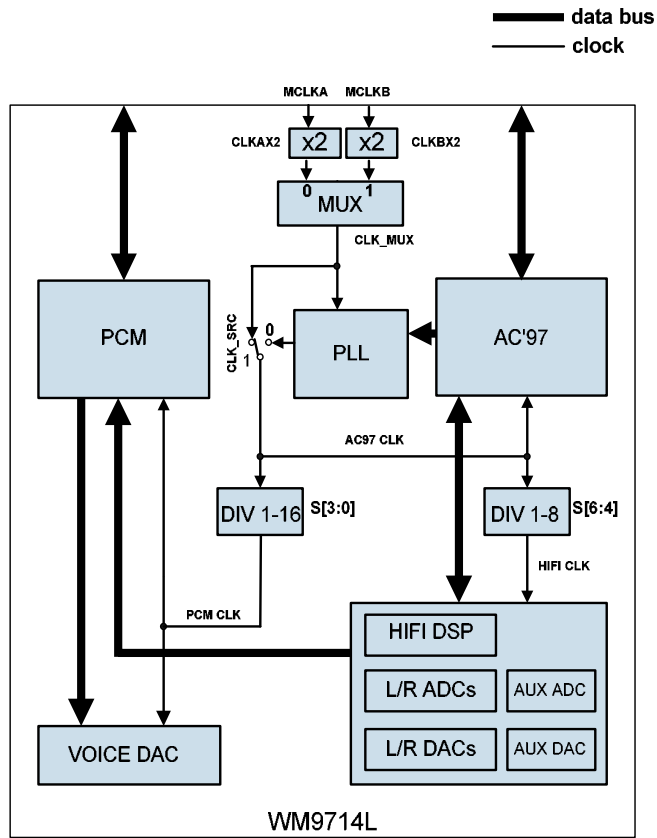

Figure 2 Clocking Architecture for WM9714L

Clock mode and division ratios are controlled by register 44h as shown in Table 2.

REGISTER ADDRESS	BIT	LABEL	DEFAULT	DESCRIPTION
44h	14:12	S _{EXT} [6:4]	000 (div 1)	Defines clock division ratio for Hi-fi block: 000: f 001: f/2 ... 111: f/8
	11:8	S _{EXT} [3:0]	0000 (div 1)	Defines clock division ratio for PCM interface and voice DAC: 0000: f 0001: f/1 ... 1111: f/16
	7	CLKSRC	1 (ext clk)	Selects between PLL clock and External clock
	5:3	PENDIV	000 (div 16)	Sets AUXADC clock divisor 000: f/16 001: f/12 010: f/8 011: f/6 100: f/4 101: f/3 110: f/2 111: f
	2	CLKBX2	0 (Off)	Clock doubler for MCLKB
	1	CLKAX2	0 (Off)	Clock doubler for MCLKA
	0	CLKMUX	0 (MCLKA)	Selects between MCLKA and MCLKB (N.B. On power-up clock must be present on MCLKA and must be active for 2 clock cycles after switching to MCLKB)

Table 2 Clock Muxing and Division Control

INTERNAL CLOCK FREQUENCIES

The internal clock frequencies are defined as follows (refer to Figure 2):

- AC97 CLK – nominally 24.576MHz, used to generate AC97 BITCLK at 12.288MHz.
- HIFI CLK – for HIFI playback at 48ks/s HIFI CLK = 24.576MHz. See Table 3 for voice only playback.
- PCM CLK – see Table 3 for sample rate vs clock frequency.

SAMPLE RATE	PCM CLK FREQUENCY	HIFI CLK FREQUENCY
8ks/s voice and HIFI	2.048MHz	24.576MHz
8ks/s voice only (power save)	2.048MHz	4.096MHz
16ks/s voice and HIFI	4.096MHz	24.576MHz
16ks/s voice only (power save)	4.096MHz	8.192MHz
32ks/s voice and HIFI	8.192MHz	24.576MHz
48ks/s voice and HIFI	12.288MHz	24.576MHz

Table 3 Clock Division Mode Table

AUX ADC

The clock for the AUXADC nominally runs at 768kHz and is derived from BITCLK. The divisor for the clock generator is set by PENDIV. This enables the AUXADC clock frequency to be set according to power consumption and conversion rate considerations.

PLL MODE

The PLL operation is controlled by register 46h (see Table 4) and has two modes of operation:

- Integer N
- Fractional N

The PLL has been optimized for nominal input clock (PLL_IN) frequencies in the range 8.192MHz – 19.661MHz (LF=0) and 2.048MHz – 4.9152MHz (LF=1).

Through use of a clock divider (div by 2 / 4) on the input to the PLL frequencies up to 78.6MHz can be accommodated. The input clock divider is enabled by DIVSEL (0=Off) and the division ratio is set by DIVCTL (0=div2, 1=div4).

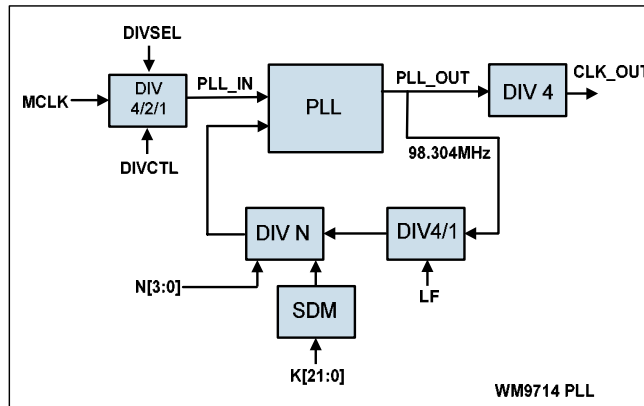

Figure 3 PLL Architecture

REGISTER ADDRESS	BIT	LABEL	DEFAULT	DESCRIPTION
46h	15:12	N[3:0]	0000	PLL integer division control (must be set between 5-12 for integer N mode)
	11	LF	0 = off	Allows PLL operation with low frequency input clocks (< 8.192MHz)
	10	SDM	0 = off	Sigma Delta Modulator enable. Allows fractional N division
	9	DIVSEL	0 = off	Enables input clock to PLL to be divided by 2 or 4. Use if input clock is above 14.4MHz
	8	DIVCTL	0	Controls division mode when DIVSEL is high. 0 = div by 2, 1 = div by 4.
	6:4	PGADDR	000	Pager address bits to access programming of K[21:0] and S _{PLL} [7:0]
	3:0	PGDATA	0000	Pager data bits

Table 4 PLL Clock Control

INTEGER N MODE

The nominal output frequency of the PLL (PLL_OUT) is 98.304MHz which is divided by 4 to achieve a nominal system clock of 24.576MHz.

The integer division ratio (N) is determined by: F_{PLL_out} / F_{PLL_IN} , and is set by N[3:0] and must be in the range 5 to 12 for integer N operation (0101 = div by 5, 1100 = div by 12). Note that setting LF=1 enables a further division by 4 required for input frequencies in the range 2.048MHz – 4.096MHz.

Integer N mode is selected by setting SDM=0.

FRACTIONAL N MODE

Fractional N mode provides a divide resolution of $1/2^{22}$ and is set by K[21:0] (register 46h, see section PLL Register Page Address Mapping). The relationship between the required division X, the fractional division K[21:0] and the integer division N[3:0] is:

$$K = 2^{22}(X - N)$$

where $0 < (X - N) < 1$ and K is rounded to the nearest whole number.

For example, if the PLL_IN clock is 13MHz and the desired PLL_OUT clock is 98.304MHz then the desired division, X, is 7.5618. So N[3:0] will be 7h and K[21:0] will be 23F488h to produce the desired 98.304MHz clock (see Table 5).

INPUT CLOCK (PLL_IN)	DESIRED PLL OUTPUT (PLL_OUT)	DIVISION REQUIRED (X)	FRACTIONAL DIVISION (K)	INTEGER DIVISION (N)
2.048MHz	98.304MHz	48	0	12x4*
4.096MHz	98.304MHz	24	0	6x4*
12.288MHz	98.304MHz	8	0	8
13MHz	98.304MHz	7.5618	0.5618	7
27MHz (13.5MHz)**	98.304MHz	7.2818	0.2818	7

*Divide by 4 enabled in PLL feedback path for low frequency inputs. (LF = 1)
 **Divide by 2 enabled at PLL input for frequencies > 14.4MHz > 38MHz (DIVSEL = 1, DIVCTL = 0)

Table 5 PLL Modes of Operation

PLL REGISTER PAGE ADDRESS MAPPING

The clock division control bits S_{PLL}[6:0] and the PLL fractional N division bits are accessed through register 46h using a sub-page address system. The 3 bit pager address allows 8 blocks of 4 bit data words to be accessed whilst the register address is set to 46h. This means that when register address 46h is selected a further 7 cycles of programming are required to set all of the page data bits. Control bit allocation for these page addresses is described in Table 6.

PAGE ADDRESS	BIT	LABEL	DEFAULT	DESCRIPTION
111	31:28	S _{PLL} [6:4]	0h	Clock division control bus S _{PLL} [6:0]. Clock divider reads this control word if PLL is enabled
110	27:24	S _{PLL} [3:0]	0h	
101	23:22	SPARE	0h	Spare control bits
	21:20	K[21:0]	0h	Sigma Delta Modulator control word for fractional N division. Division resolution is $1/2^{22}$
100	19:16		0h	
011	15:12		0h	
010	11:8		0h	
001	7:4		0h	
000	3:0		0h	
			0h	

Table 6 Pager Control Bit Allocation

Powerdown for the PLL and internal clocks is via registers 26h and 3Ch (see Table 7).

REGISTER ADDRESS	BIT	LABEL	DEFAULT	DESCRIPTION
26h	13	PR5	1 (Off)	Internal clock disable (active high)
3Ch	9	PLL	1 (Off)	PLL powerdown (active high)
N.B. both PR5 and PLL must be asserted low before PLL is enabled				

Table 7 PLL Powerdown Control

DATA AND CONTROL INTERFACE

The WM9714L has two interfaces, a data and control AC'97 interface and a data only PCM interface. The AC'97 interface is available through dedicated pins (SDATAOUT, SDATAIN, SYNC, BITCLK and RESETB) and is the sole control interface with access to all data streams on the device except for the Voice DAC. The PCM interface is available through the GPIO pins (PCMCLK, PCMFS, PCMDAC and PCMADC) and provides access to the Voice DAC. It can also transmit the data from the Stereo ADC. This can be useful, for example, to allow both sides of a phone conversation to be recorded by mixing the transmit and receive paths on one of the ADC channels and transmitting it over the PCM interface.

AC97 INTERFACE

INTERFACE PROTOCOL

The WM9714L has a single AC'97 interface for both data transfer and control. The AC-Link uses 5 wires:

- SDATAIN (pin 8) carries data from the WM9714L to the controller
- SDATAOUT (pin 5) carries data from the controller to the WM9714L
- BITCLK (pin 6) is a clock, derived from either MCLKA or MCLKB inputs and supplied to the controller.
- SYNC is a synchronization signal generated by the controller and passed to the WM9714L
- RESETB resets the WM9714L to its default state

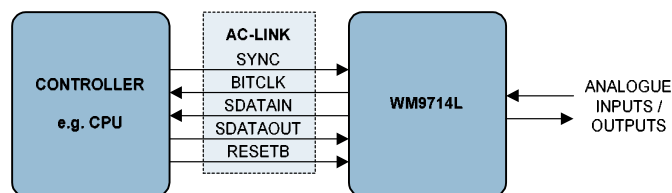

Figure 4 AC-Link Interface (typical case with BITCLK generated by the AC97 codec)

The SDATAIN and SDATAOUT signals each carry 13 time-division multiplexed data streams (slots 0 to 12). A complete sequence of slots 0 to 12 is referred to as an AC-Link frame, and contains a total of 256 bits. The frame rate is 48kHz. This makes it possible to simultaneously transmit and receive multiple data streams (e.g. audio, AUXDAC, control) at sample rates up to 48kHz.

Detailed information can be found in the AC'97 (Revision 2.2) specification, which can be obtained at www.intel.com/labs/media/audio/

Note:

SDATAOUT and SYNC must be held low for when RESETB is applied. These signals must be held low for the entire duration of the RESETB pulse and especially during the low-to-high transition of RESETB. If either is set high during reset the AC'97 device may enter test modes. Information relating to this operation is available in the AC'97 specification or in Wolfson applications note WAN-0104 available at www.wolfsonmicro.com.

PCM INTERFACE

OPERATION

WM9714L can implement a PCM voice codec function using the dedicated VXDAC and either one or both of the existing hi-fi ADC's. In PCM codec mode, VXDAC input and ADC output are interfaced via a PCM style port via GPIO pins.

This interface can support one ADC channel, or stereo/dual ADC channels if required, (two channels of data are sent per PCM frame as back to back words).

In voice only mode, the AC link is used only for control information, not audio data. Therefore it will generally be shut down (PR4=1), except when control data must be sent.

The PCM interface makes use of 4 of the GPIO interface pins, for clock, frame, and data in/out. If the PCM codec function is not enabled then the GPIO pins may be used for other functions as on WM9714L

INTERFACE PROTOCOL

The WM9714L PCM audio interface is used for the input of data to the Voice DAC and the output of data from the Stereo ADC. When enabled, the PCM audio interface uses four GPIO pins:

- GPIO1/PCMCLK: Bit clock
- GPIO3/PCMFS: Frame Sync
- GPIO4/PCMDAC: Voice DAC data input
- GPIO5/PCMADC: Stereo ADC data output

When not enabled the GPIOs may be used for other functions on the WM9714L.

PCM INTERFACE MODES

The WM9714L PCM audio interface may be configured in one of four modes:

- Disabled Mode: The WM9714L disables and tri-states all PCM interface pins. Any clock input is ignored and ADC/DAC data is not transferred.
- Slave Mode: The WM9714L accepts PCMCLK and PCMFS as inputs from an external source.
- Master Mode: The WM9714L generates PCMCLK and PCMFS as outputs.
- Partial Master Mode: The WM9714L generates PCMCLK as an output, and accepts PCMFS as an external input.

The PCMDAC and PCMADC pins are normally used as DAC input and ADC output respectively. The WM9714L allows these functions to be swapped allowing DAC input on PCMADC and ADC output on PCMDAC.

PCM AUDIO DATA FORMATS

Four different audio data formats are supported:

- DSP mode
- Left justified
- Right justified
- I²S

All four of these modes are MSB first. They are described below. Refer to the Electrical Characteristic section for timing information.

The PCM Interface may be configured for Mono mode, where only one channel of ADC data is output. In this mode the interface should be configured for DSP mode. A short or long frame sync is supported and the MSB is available on either the 1st (mode B) or 2nd (mode A) rising edge of VXCLK.

Note that when operating in stereo mode the mono Voice DAC always uses the left channel data as its input.

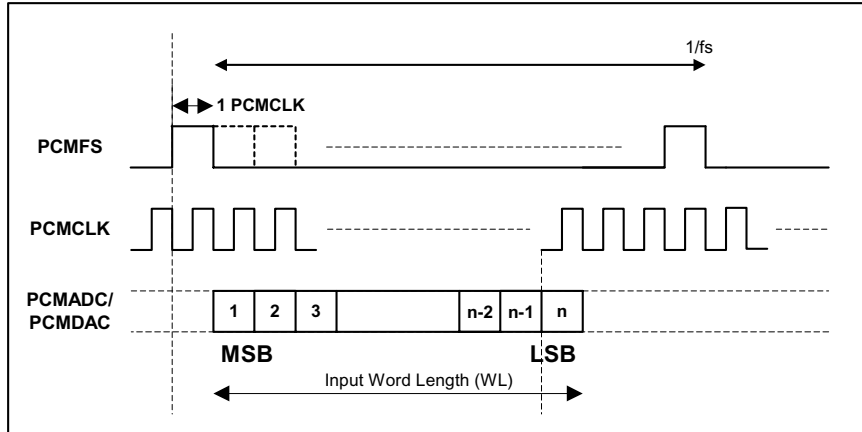

Figure 5 PCM Interface Mono Mode (mode A, FSP=0)

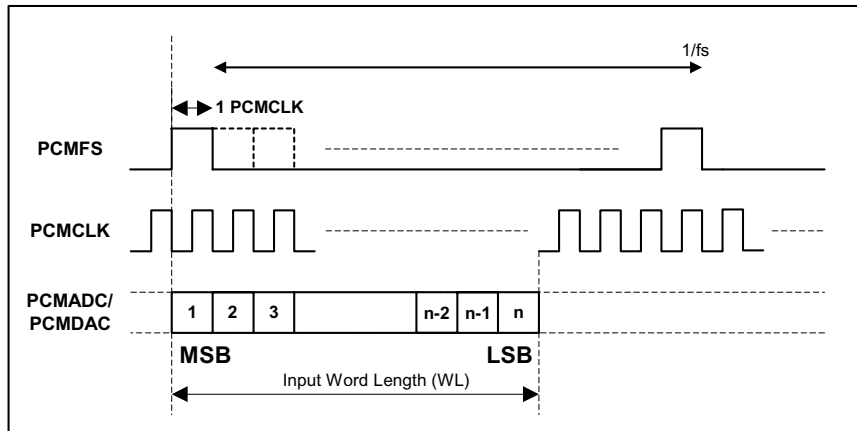

Figure 6 PCM Interface Mono Mode (mode B, FSP=1)

In DSP mode, the left channel MSB is available on either the 1st (mode B) or 2nd (mode A) rising edge of PCMCLK (selectable by FSP) following a rising edge of PCMFS. Right channel data immediately follows left channel data. Depending on word length, PCMCLK frequency and sample rate, there may be unused PCMCLK cycles between the LSB of the right channel data and the next sample.

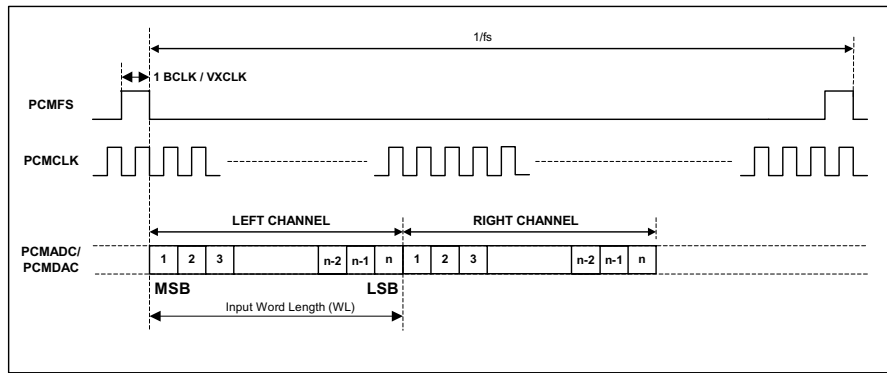

Figure 7 DSP Mode Audio Interface (mode A, FSP=0)

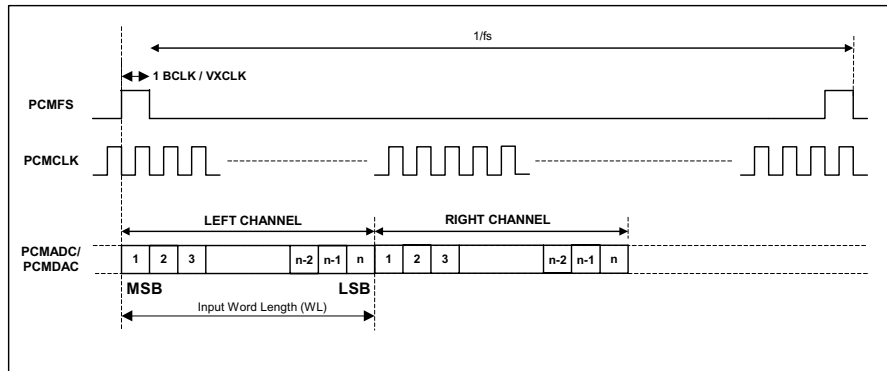

Figure 7 DSP Mode Audio Interface (mode B, FSP=1)

In Left Justified mode, the MSB is available on the first rising edge of PCMCLK following a PCMFs transition. The other bits up to the LSB are then transmitted in order. Depending on word length, PCMCLK frequency and sample rate, there may be unused PCMCLK cycles before each PCMFs transition.

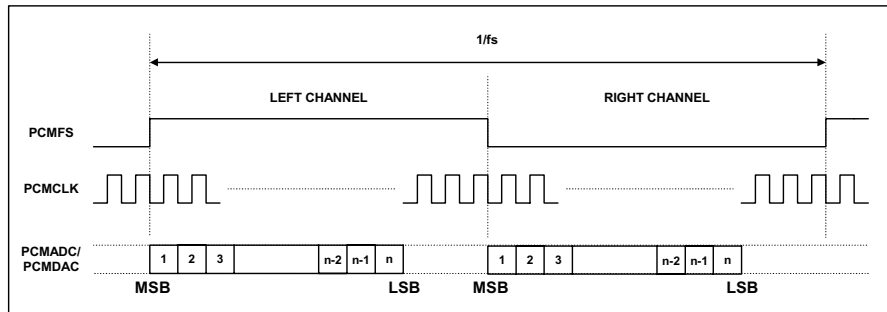

Figure 8 Left Justified Audio Interface (assuming n-bit word length)

In Right Justified mode, the LSB is available on the last rising edge of PCMCLK before a PCMFs transition. All other bits are transmitted before (MSB first). Depending on word length, PCMCLK frequency and sample rate, there may be unused PCMCLK cycles after each PCMFs transition.

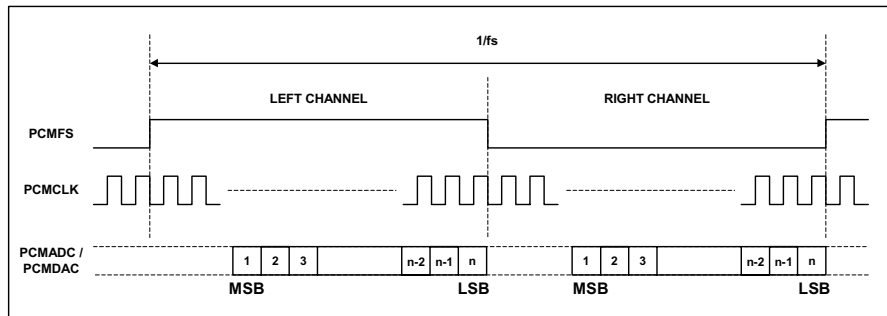

Figure 9 Right Justified Audio Interface (assuming n-bit word length)

In I²S mode, the MSB is available on the second rising edge of PCMCLK following a PCMFs transition. The other bits up to the LSB are then transmitted in order. Depending on word length, PCMCLK frequency and sample rate, there may be unused PCMCLK cycles between the LSB of one sample and the MSB of the next.

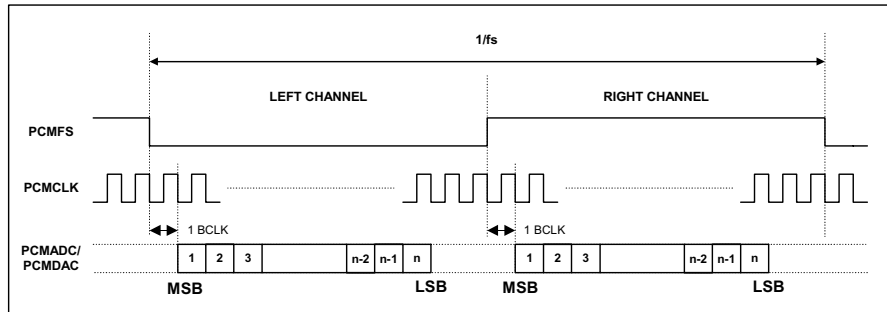

Figure 10 I²S Justified Audio Interface (assuming n-bit word length)

CONTROL

The register bits controlling PCM audio format, word length and operating modes are summarised below. CTRL must be set to override the normal use of the PCM interface pins as GPIOs, MODE must be set to specify master/slave modes.

REGISTER ADDRESS	BIT	LABEL	DEFAULT	DESCRIPTION
36h PCM Control	15	CTRL	0	Sets function and control registers for GPIO / PCM interface pins. 0 = GPIO pins as GPIOs 1 = GPIO pins configured as PCM interface and controlled by this register
	14:13	MODE	10	PCM interface mode when CTRL=1 00 = PCM interface disabled [PCMCLK tri-stated, PCMFs tri-stated] 01 = PCM interface in slave mode [PCMCLK as input, PCMFs as input] 10 = PCM interface in master mode [PCMCLK as output, PCMFs as output] 11 = PCM interface in partial master mode [PCMCLK as output, PCMFs as input]
	12	SWAP	0	PCM data swap 0 = DAC data input on PCMDAC, ADC data output on PCMADC 1 = DAC data input on PCMADC, ADC data output on PCMDAC

REGISTER ADDRESS	BIT	LABEL	DEFAULT	DESCRIPTION
	11:9	DIV	010	Voice DAC clock to PCMCLK divider. In master mode PCMCLK is derived from Voice DAC clock. 000 : PCMCLK = Voice DAC clock 001 : PCMCLK = Voice DAC clock / 2 010 : PCMCLK = Voice DAC clock / 4 011 : PCMCLK = Voice DAC clock / 8 100 : PCMCLK = Voice DAC clock / 16
	8	VDACOSR	1	VXDAC oversample rate: 0: 128 x fs 1: 64 x fs
	7	CP	0	PCMCLK polarity 1 = invert PCMCLK polarity 0 = normal PCMCLK polarity
	6	FSP	0	Right, Left and I ² S modes – PCMFS polarity 1 = invert PCMFS polarity 0 = normal PCMFS polarity DSP Mode – mode A/B select 0 = MSB is available on 2nd PCMCLK rising edge after LRC rising edge (mode A) 1 = MSB is available on 1st PCMCLK rising edge after LRC rising edge (mode B)
	5:4	SEL	10	PCM ADC channel select 00 = Output left and right ADC data 01 = Swap and output left and right ADC data 10 = Output left ADC data only 11 = Output right ADC data only
	3:2	WL	00	PCM Data Word Length 11 = 32 bits (see Note) 10 = 24 bits 01 = 20 bits 00 = 16 bits
	1:0	FMT	11	PCM Data Format Select 11 = DSP Mode 10 = I ² S Format 01 = Left justified 00 = Right justified

Table 8 PCM Codec Control

Note: Right justified does not support 32-bit data.

AUDIO ADCS

STEREO ADC

The WM9714L has a stereo sigma-delta ADC to digitize audio signals. The ADC achieves high quality audio recording at low power consumption. The ADC sample rate can be controlled by writing to a control register (see "Variable Rate Audio"). It is independent of the DAC sample rate.

To save power, the left and right ADCs can be separately switched off using the Powerdown bits ADCL and ADCR (register 3Ch, bits 5:4), whereas PR0 disables both ADCs (see "Power Management" section). If only one ADC is running, the same ADC data appears on both the left and right AC-Link slots.

The output from the ADC can be sent over either the AC link as usual, or output via the PCM interface which may be configured on the GPIO pins.

HIGH PASS FILTER

The WM9714L audio ADC incorporates a digital high pass filter that eliminates any DC bias from the ADC output data. The filter is enabled by default. For DC measurements, it can be disabled by writing a '1' to the HPF bit (register 5Ch, bit 3).

This high pass filter corner frequency can be selected to have different values in WM9714L, to suit applications such as voice where a higher cutoff frequency is required.

REGISTER ADDRESS	BIT	LABEL	DEFAULT	DESCRIPTION
5Ah	5:4	HPMODE	00	HPF corner frequency 00: 7Hz @ Fs=48kHz 01: 82Hz @ Fs=16kHz 10: 82Hz @ Fs=8kHz 11: 170Hz @ Fs=8kHz
Note: the filter corner frequency is proportional to the sample rate.				

Table 9 ADC Highpass Filter Frequency Control

ADC SLOT MAPPING

By default, the output of the left audio ADC appears on slot 3 of the SDATAIN signal (pin 8), and the right ADC data appears on slot 4. However, the ADC output data can also be sent to other slots, by setting the ASS (ADC slot select) control bits as shown below.

REGISTER ADDRESS	BIT	LABEL	DEFAULT	DESCRIPTION
5Ch Additional Functions (2)	1:0	ASS	00	ADC to slot mapping 00: Left = Slot 3, Right = Slot 4 (default) 01: Left = Slot 7, Right = Slot 8 10: Left = Slot 6, Right = Slot 9 11: Left = Slot 10, Right = Slot 11
	3	HPF	0	High-pass filter disable 0: Filter enabled (for audio) 1: Filter disabled (for DC measurements)

Table 10 ADC Control

RECORD SELECTOR

The record selector determines which input signals are routed into the audio ADC. The left and right channels can be selected independently. This is useful for recording a phone call: one channel can be used for the RX signal and the other for the TX signal, so that both sides of the conversation are digitized.

REGISTER ADDRESS	BIT	LABEL	DEFAULT	DESCRIPTION
14h Record Routing / Mux Select	6	RECBST	0	20dB Boost 1: Boost ADC input signal by 20dB 0 :No boost
	5:3	RECSL	000	Left ADC signal source 000: MICA (pre-PGA) 001: MICB (pre-PGA) 010: LINEL (pre-PGA) 011: MONOIN (pre-PGA) 100: Headphone Mix (left) 101: Speaker Mix 110: Mono Mix 111: Reserved (do not use this setting)
	2:0	RECSR	000	Right ADC signal source 000: MICA (pre-PGA) 001: MICB (pre-PGA) 010: LINER (pre-PGA) 011: MONOIN (pre-PGA) 100: Headphone Mix (right) 101: Speaker Mix 110: Mono Mix 111: Reserved (do not use this setting)

Table 11 Audio Record Selector

RECORD GAIN

The amplitude of the signal that enters the audio ADC is controlled by the Record PGA (Programmable Gain Amplifier). The PGA gain can be programmed either by writing to the Record Gain register, or by the Automatic Level Control (ALC) circuit (see next section). When the ALC is enabled, any writes to the Record Gain register have no effect.

Two different gain ranges can be implemented: the standard gain range defined in the AC'97 standard, or an extended gain range with smaller gain steps. The ALC circuit always uses the extended gain range, as this has been found to result in better sound quality.

REGISTER ADDRESS	BIT	LABEL	DEFAULT	DESCRIPTION	
12h Record Gain	15	RMU	1	Mute Audio ADC (both channels) 1: Mute (OFF) 0: No Mute (ON)	
	14	GRL	0	Gain range select (left) 0: Standard (0 to 22.5dB, 1.5dB step size) 1: Extended (-17.25 to +30dB, 0.75dB steps)	
	13:8	RECVOLL	000000	Record Volume (left)	
				Standard (GRL=0)	Extended (GRL=1)
				XX0000: 0dB XX0001: +1.5dB ... (1.5dB steps) XX1111: +22.5dB	000000: -17.25dB 000001: -16.5dB ... (0.75dB steps) 111111: +30dB
	7	ZC	0	Zero Cross Enable 0: Record Gain changes immediately 1: Record Gain changes when signal is zero or after time-out	
	6	GRR	0	Gain range select (right) Similar to GRL	
5:0	RECVOLR	000000	Record Volume (right) Similar to RECVOLR		

Table 12 Record Gain Register

The output of the Record PGA can also be mixed into the phone and/or headphone outputs (see "Audio Mixers"). This makes it possible to use the ALC function for the microphone signal in a smartphone application.

REGISTER ADDRESS	BIT	LABEL	DEFAULT	DESCRIPTION
14h Record Routing	15:14	R2H	11 (mute)	Controls record mux to headphone mixer paths. 00=stereo, 01=left rec mux only, 10=right rec mux only, 11=mute left and right
	13:11	R2HVOL	010 (0dB)	Controls gain of record mux l/r to headphone mixer paths. 000: +6dB 001: +3dB ... (3dBsteps) 111: -15dB
	10:9	R2M	11 (mute)	Controls record mux to mono mixer path. 00=stereo, 01=left rec mux only, 10=right rec mux only, 11=mute left and right
	8	R2MBST	0 (OFF)	Enables 20dB gain boost for record mux to mono mixer path

Table 13 Record PGA Routing Control

AUTOMATIC LEVEL CONTROL

The WM9714L has an automatic level control that aims to keep a constant recording volume irrespective of the input signal level. This is achieved by continuously adjusting the PGA gain so that the signal level at the ADC input remains constant. A digital peak detector monitors the ADC output and changes the PGA gain if necessary.

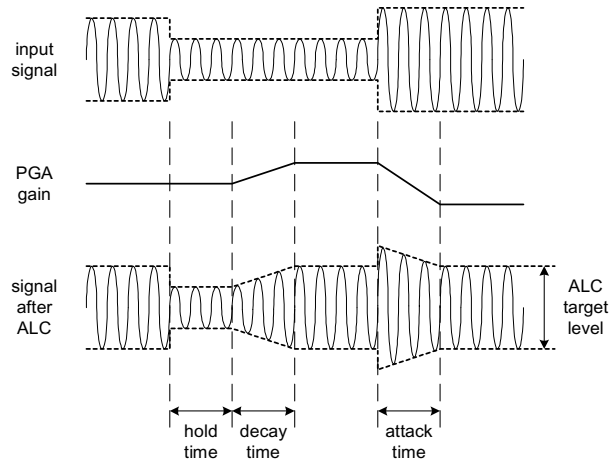

Figure 11 ALC Operation

The ALC function is enabled using the ALCSEL control bits. When enabled, the recording volume can be programmed between -6dB and -28.5dB (relative to ADC full scale) using the ALCL register bits.

HLD, DCY and ATK control the hold, decay and attack times, respectively.

HOLD TIME

Hold time is the time delay between the peak level detected being below target and the PGA gain beginning to ramp up. It can be programmed in power-of-two (2^n) steps, e.g. 2.67ms, 5.33ms, 10.67ms etc. up to 43.7s. Alternatively, the hold time can also be set to zero. The hold time only applies to gain ramp-up, there is no delay before ramping the gain down when the signal level is above target.

DECAY (GAIN RAMP-UP) TIME

Decay time is the time that it takes for the PGA gain to ramp up across 90% of its range (e.g. from -15dB up to 27.75dB). The time it takes for the recording level to return to its target value therefore depends on both the decay time and on the gain adjustment required. If the gain adjustment is small, it will be shorter than the decay time. The decay time can be programmed in power-of-two (2^n) steps, from 24ms, 48ms, 96ms, etc. to 24.58s.

ATTACK (GAIN RAMP-DOWN) TIME

Attack time is the time that it takes for the PGA gain to ramp down across 90% of its range (e.g. from 27.75dB down to -15B gain). The time it takes for the recording level to return to its target value therefore depends on both the attack time and on the gain adjustment required. If the gain adjustment is small, it will be shorter than the attack time. The attack time can be programmed in power-of-two (2^n) steps, from 6ms, 12ms, 24ms, etc. to 6.14s.

When operating in stereo, the peak detector takes the maximum of left and right channel peak values, and any new gain setting is applied to both left and right PGAs, so that the stereo image is preserved. However, the ALC function can also be enabled on one channel only. In this case, only one PGA is controlled by the ALC mechanism, while the other channel runs independently with its PGA gain set through the control register.

When one ADC channel is unused, the peak detector disregards that channel. The ALC function can also operate when the two ADC outputs are mixed to mono in the digital domain, but not if they are mixed to mono in the analogue domain, before entering the ADCs.

ALC ZERO CROSS

The ALC has a zero cross detection circuit. When enabled, the PGA gain will be updated when the signal is at zero or after a time out period. This is controlled through the ALC enable ALCZC, register 62h bit 8, and the time out control ZC_TIMEOUT, register 62h bit 10:9. The time out signal is a function of the BITCLK period as defined in Table 14.

REGISTER ADDRESS	BIT	LABEL	DEFAULT	DESCRIPTION
62h ALC / Noise Gate Control	15:14	ALCSEL	00 (OFF)	ALC function select 00 = ALC off (PGA gain set by register) 01 = Right channel only 10 = Left channel only 11 = Stereo (PGA registers unused)
	13:11	MAXGAIN	111 (+30dB)	PGA gain limit for ALC 111 = +30dB 110 = +24dB(6dB steps) 001 = -6dB 000 = -12dB
	10:9	ZCTIMEOUT	11	Programmable zero cross timeout (delay for 12.288MHz BITCLK): 11: $2^{17} * \text{tbitclk}$ (10.67 ms) 10: $2^{16} * \text{tbitclk}$ (5.33 ms) 01: $2^{15} * \text{tbitclk}$ (2.67 ms) 00: $2^{14} * \text{tbitclk}$ (1.33 ms)
	8	ALCZC	0	ALC Zero Cross enable (overrides ZC bit in register 12h) 0: PGA Gain changes immediately 1: PGA Gain changes when signal is zero or after time-out
60h ALC Control	15:12	ALCL	1011 (-12dB)	ALC target – sets signal level at ADC input 0000 = -28.5dB FS 0001 = -27.0dB FS ... (1.5dB steps) 1110 = -7.5dB FS 1111 = -6dB FS
	11:8	HLD	0000 (0ms)	ALC hold time before gain is increased. 0000 = 0ms 0001 = 2.67ms 0010 = 5.33ms ... (time doubles with every step) 1111 = 43.691s
	7:4	DCY	0011 (192ms)	ALC decay (gain ramp-up) time 0000 = 24ms 0001 = 48ms 0010 = 96ms ... (time doubles with every step) 1010 or higher = 24.58s
	3:0	ATK	0010 (24ms)	ALC attack (gain ramp-down) time 0000 = 6ms 0001 = 12ms 0010 = 24ms ... (time doubles with every step) 1010 or higher = 6.14s

Table 14 ALC Control

MAXIMUM GAIN

The MAXGAIN register sets the maximum gain value that the PGA can be set to whilst under the control of the ALC. This has no effect on the PGA when ALC is not enabled.

PEAK LIMITER

To prevent clipping when a large signal occurs just after a period of quiet, the ALC circuit includes a limiter function. If the ADC input signal exceeds 87.5% of full scale (-1.16dB), the PGA gain is ramped down at the maximum attack rate (as when ATK = 0000), until the signal level falls below 87.5% of full scale. This function is automatically enabled whenever the ALC is enabled.

(Note: If ATK = 0000, then the limiter makes no difference to the operation of the ALC. It is designed to prevent clipping when long attack times are used).

NOISE GATE

When the signal is very quiet and consists mainly of noise, the ALC function may cause "noise pumping", i.e. loud hissing noise during silence periods. The WM9714L has a noise gate function that prevents noise pumping by comparing the signal level at the input pins (i.e. before the record PGA) against a noise gate threshold, NGTH. Provided that the noise gate function is enabled (NGAT = 1), the noise gate cuts in when:

$$\text{Signal level at ADC [dB]} < \text{NGTH [dB]} + \text{PGA gain [dB]} + \text{Mic Boost gain [dB]}$$

This is equivalent to:

$$\text{Signal level at input pin [dB]} < \text{NGTH [dB]}$$

The PGA gain is then held constant (preventing it from ramping up as it normally would when the signal is quiet). If the NGG bit is set, the ADC output is also muted when the noise gate cuts in.

The table below summarises the noise gate control register. The NGTH control bits set the noise gate threshold with respect to the ADC full-scale range. The threshold is adjusted in 1.5dB steps. Levels at the extremes of the range may cause inappropriate operation, so care should be taken with set-up of the function. Note that the noise gate only works in conjunction with the ALC function, and always operates on the same channel(s) as the ALC (left, right, both, or none).

REGISTER ADDRESS	BIT	LABEL	DEFAULT	DESCRIPTION
62h ALC / Noise Gate Control	7	NGAT	0	Noise gate function enable 1 = enable 0 = disable
	5	NGG	0	Noise gate type 0 = PGA gain held constant 1 = mute ADC output
	4:0	NGTH(4:0)	00000	Noise gate threshold 00000: -76.5dBFS 00001: -75dBFS ... 1.5 dB steps 11110: -31.5dBFS 11111: -30dBFS

Table 15 Noise Gate Control

AUDIO DACS

STEREO DAC

The WM9714L has a stereo sigma-delta DAC that achieves high quality audio playback at low power consumption. Digital tone control, adaptive bass boost and 3-D enhancement functions operate on the digital audio data before it is passed to the stereo DAC. (Contrary to the AC'97 specification, they have no effect on analogue input signals or signals played through the auxiliary DAC. Nevertheless, the ID2 and ID5 bits in the reset register, 00h, are set to '1' to indicate that the WM9714L supports tone control and bass boost.)

The DAC output has a PGA for volume control. The DAC sample rate can be controlled by writing to a control register (see "Variable Rate Audio"). It is independent of the ADC sample rate.

When not in use the DACs can be separately powered down using the Powerdown register bits DACL and DACR (register 3Ch, bits [7:6]).

STEREO DAC VOLUME

The volume of the DAC output signal is controlled by a PGA (Programmable Gain Amplifier). Each DAC can be mixed into the headphone, speaker and mono mixer paths (see "Audio Mixers") controlled by register 0Ch.

Each DAC-to-mixer path has an independent mute bit. When all DAC-to-mixer paths are muted the DAC PGA is muted automatically.

When not in use the DAC PGAs can be powered down using the Powerdown register bits DACL and DACR (register 3Ch, bits [7:6]).

REGISTER ADDRESS	BIT	LABEL	DEFAULT	DESCRIPTION
0Ch DAC Volume	15	D2H	1	Mute DAC path to headphone mixer 1: Mute, 0: No mute (ON)
	14	D2S	1	Mute DAC path to speaker mixer 1: Mute, 0: No mute (ON)
	13	D2M	1	Mute DAC path to mono mixer 1: Mute, 0: No mute (ON)
	12:8	DACL VOL	01000 (0dB)	Left DAC Volume 00000: +12dB ... (1.5dB steps) 11111: -34.5dB
	4:0	DACR VOL	01000 (0dB)	Right DAC Volume similar to DACLVOL
5Ch Additional Functions (2)	15	AMUTE	0	Read-only bit to indicate auto-muting 1: DAC auto-muted 0: DAC not muted
	7	AMEN	0	DAC Auto-Mute Enable 1: Automatically mutes analogue output of stereo DAC if digital input is zero 0: Auto-mute OFF

Table 16 Stereo DAC Volume Control

TONE CONTROL / BASS BOOST

The WM9714L provides separate controls for bass and treble with programmable gains and filter characteristics. This function operates on digital audio data before it is passed to the audio DACs.

Bass control can take two different forms:

- Linear bass control: bass signals are amplified or attenuated by a user programmable gain. This is independent of signal volume, and very high bass gains on loud signals may lead to signal clipping.
- Adaptive bass boost: The bass volume is amplified by a variable gain. When the bass volume is low, it is boosted more than when the bass volume is high. This method is recommended because it prevents clipping, and usually sounds more pleasant to the human ear.

Treble control applies a user programmable gain, without any adaptive boost function.

Treble, linear bass and 3D enhancement can all produce signals that exceed full-scale. In order to avoid limiting under these conditions, it is recommended to set the DAT bit to attenuate the digital input signal by 6dB. The gain at the outputs should be increased by 6dB to compensate for the attenuation. Cut-only tone adjustment and adaptive bass boost cannot produce signals above full-scale and therefore do not require the DAT bit to be set.

REGISTER ADDRESS	BIT	LABEL	DEFAULT	DESCRIPTION		
20h DAC Tone Control	15	BB	0	Bass Mode 0 = Linear bass control 1 = Adaptive bass boost		
	12	BC	0	Bass Cut-off Frequency 0 = Low (130Hz at 48kHz sampling) 1 = High (200Hz at 48kHz sampling)		
	11:8	BASS	1111 (OFF)	Bass Intensity		
				Code	BB=0	BB=1
				0000	+9dB	15 (max)
				0001	+9dB	14
				0010	+7.5dB	13
				...	(1.5dB steps)	...
				0111	0dB	8
				...	(1.5dB steps)	...
1011-1101	-6dB	4-2				
1110	-6dB	1 (min)				
1111	Bypass (OFF)					
6	DAT	0	-6dB attenuation 0 = Off 1 = On			
4	TC	0	Treble Cut-off Frequency 0 = High (8kHz at 48kHz sampling) 1 = Low (4kHz at 48kHz sampling)			
3:0	TRBL	1111 (Disabled)	Treble Intensity 0000 or 0001 = +9dB 0010 = +7.5dB ... (1.5dB steps) 1011 to 1110 = -6dB 1111 = Treble Control Disabled			

Table 17 DAC Tone Control

Note:

1. All cut-off frequencies change proportionally with the DAC sample rate.

3D STEREO ENHANCEMENT

The 3D stereo enhancement function artificially increases the separation between the left and right channels by amplifying the (L-R) difference signal in the frequency range where the human ear is sensitive to directionality. The programmable 3D depth setting controls the degree of stereo expansion introduced by the function. Additionally, the upper and lower limits of the frequency range used for 3D enhancement can be selected using the 3DFILT control bits.

REGISTER ADDRESS	BIT	LABEL	DEFAULT	DESCRIPTION
40h General Purpose	13	3DE	0 (disabled)	3D enhancement enable
1Eh DAC 3D Control	5	3DLC	0	Lower Cut-off Frequency 0 = Low (200Hz at 48kHz sampling) 1 = High (500Hz at 48kHz sampling)
	4	3DUC	0	Upper Cut-off Frequency 0 = High (2.2kHz at 48kHz sampling) 1 = Low (1.5kHz at 48kHz sampling)
	3:0	3DDEPTH	0000	3D Depth 0000: 0% (minimum 3D effect) 0001: 6.67% ...(6.67% steps) 1110: 93.3% 1111: 100% (maximum)

Table 18 Stereo Enhancement Control

Note:

- All cut-off frequencies change proportionally with the DAC sample rate.

VOICE DAC

VXDAC is a 16-bit mono DAC intended for playback of Rx voice signals input via the PCM interface. Typically it is used at 8ks/s, but may be used at other sample rates up to 48ks/s.

The analogue output of VXDAC is routed directly into the output mixers. The signal gain into each mixer can be adjusted at the mixer inputs using control register 1Eh.

When not in use the VXDAC can be powered down using the Powerdown register bit VXDAC (register 3Ch, bit 12).

REGISTER ADDRESS	BIT	LABEL	DEFAULT	DESCRIPTION
3Ch Powerdown (1)	12	VXDAC	1	VXDAC powerdown bit 1: OFF, 0: ON
18h VXDAC Output Control	15	V2H	1	Mute VXDAC path to headphone mixer 1: Mute, 0: No mute (ON)
	14:12	V2HVOL	010 (0dB)	VXDAC to headphone mixer gain 000: +6dB ... (3dB steps) 111: -15dB
	11	V2S	1	Mute VXDAC path to speaker mixer 1: Mute, 0: No mute (ON)
	10:8	V2SVOL	010 (0dB)	VXDAC to speaker mixer gain 000: +6dB ... (3dB steps) 111: -15dB
	7	V2M	1	Mute VXDAC path to mono mixer 1: Mute, 0: No mute (ON)
	6:4	V2MVOL	010 (0dB)	VXDAC to mono mixer gain 000: +6dB ... (3dB steps) 111: -15dB

Table 19 VXDAC Control

AUXILIARY DAC

AUXDAC is a simple 12-bit mono DAC. It can be used to generate DC signals (with the numeric input written into a control register), or AC signals such as telephone-quality ring tones or system beeps (with the input signal supplied through an AC-Link slot). In AC mode (XSLE = 1), the input data is binary offset coded; in DC mode (XSLE = 0), there is no offset.

The analogue output of AUXDAC is routed directly into the output mixers. The signal gain into each mixer can be adjusted at the mixer inputs using control register 12h. In slot mode (XSLE = 1), the AUXDAC also supports variable sample rates (See "Variable Rate Audio" section).

When not in use the auxiliary DAC can be powered down using the Powerdown register bit AUXDAC (register 3Ch, bit 11).

REGISTER ADDRESS	BIT	LABEL	DEFAULT	DESCRIPTION
3Ch Powerdown (1)	11	AUXDAC	0	AUXDAC powerdown 1: OFF, 0: ON
64h AUXDAC Input Control	15	XSLE	0	AUXDAC input selection 0: from AUXDACVAL (for DC signals) 1: from AC-Link slot selected by AUXDACSLT (for AC signals)
	14:12	AUXDAC SLT	000	AUXDAC Input Selection 000 – Slot 5, bits 8-19 (with XSLE=1) 001 – Slot 6, bits 8-19 (with XSLE=1) 010 – Slot 7, bits 8-19 (with XSLE=1) 011 – Slot 8, bits 8-19 (with XSLE=1) 100 – Slot 9, bits 8-19 (with XSLE=1) 101 – Slot 10, bits 8-19 (with XSLE=1) 110 – Slot 11, bits 8-19 (with XSLE=1) 111 – RESERVED (do not use)
	11:0	AUXDAC VAL	000h	AUXDAC Digital Input (with XSLE=0) 000h: minimum FFFh: full-scale
1Ah AUXDAC Output Control	15	A2H	1	Mute AUXDAC path to headphone mixer 1: Mute, 0: No mute (ON)
	14:12	A2HVOL	010 (0dB)	AUXDAC to headphone mixer gain 000: +6dB ... (3dB steps) 111: -15dB
	11	A2S	1	Mute AUXDAC path to speaker mixer 1: Mute, 0: No mute (ON)
	10:8	A2SVOL	010 (0dB)	AUXDAC to speaker mixer gain 000: +6dB ... (3dB steps) 111: -15dB
	7	A2M	1	Mute AUXDAC path to mono mixer 1: Mute, 0: No mute (ON)
	6:4	A2MVOL	010 (0dB)	AUXDAC to mono mixer gain 000: +6dB ... (3dB steps) 111: -15dB

Table 20 AUXDAC Control

VARIABLE RATE AUDIO / SAMPLE RATE CONVERSION

By using an AC'97 Rev2.2 compliant audio interface, the WM9714L can record and playback at all commonly used audio sample rates, and offer full split-rate support (i.e. the DAC, ADC and AUXDAC sample rates are completely independent of each other – any combination is possible).

The default sample rate is 48kHz. If the VRA bit in register 2Ah is set, then other sample rates can be selected by writing to registers 2Ch, 32h and 2Eh. The AC-Link continues to run at 48k frames per second irrespective of the sample rate selected. However, if the sample rate is less than 48kHz, then some frames do not carry an audio sample.

REGISTER ADDRESS	BIT	LABEL	DEFAULT	DESCRIPTION
2Ah Extended Audio Stat/Ctrl	0	VRA	0 (OFF)	Variable Rate Audio 0: OFF (DAC and ADC run at 48kHz) 1: ON (sample rates determined by registers 2Ch and 32h)
2Ch Audio DAC Sample Rate	15:0	DACSR	BB80h (48kHz)	Audio DAC sample rate 1F40h: 8kHz 2B11h: 11.025kHz 2EE0h: 12kHz 3E80h: 16kHz 5622h: 22.05kHz 5DC0h: 24kHz 7D00h: 32kHz AC44h: 44.1kHz BB80h: 48kHz Any other value defaults to the nearest supported sample rate
32h Audio ADC Sample Rate	15:0	ADCSR	BB80h (48kHz)	Audio ADC sample rate similar to DACSR
2Eh AUXDAC Sample Rate	15:0	AUXDA CSR	BB80h (48kHz)	AUXDAC sample rate similar to DACSR

Table 21 Audio Sample Rate Control

AUDIO INPUTS

The following sections give an overview of the analogue audio input pins and their function. For more information on recommended external components, please refer to the "Applications Information" section.

LINE INPUT

The LINEL and LINER inputs are designed to record line level signals, and/or to mix into one of the analogue outputs.

Both pins are directly connected to the record selector. The record PGA adjusts the recording volume, controlled by register 12h or by the ALC function.

For analogue mixing, the line input signals pass through a separate PGA, controlled by register 0Ah. The signals can be mixed into the headphone, speaker and mono mixer paths (see "Audio Mixers").

Each LINE-to-mixer path has an independent mute bit. When all LINE-to-mixer paths are muted the line PGA is muted automatically. When the line inputs are not used, the line PGA can be switched off to save power (see "Power Management" section).

LINEL and LINER are biased internally to the reference voltage VREF. Whenever the inputs are muted or the device placed into standby mode, the inputs remain biased to VREF using special anti-thump circuitry to suppress any audible clicks when changing inputs.

REGISTER ADDRESS	BIT	LABEL	DEFAULT	DESCRIPTION
0Ah	15	L2H	1	Mute LINE path to headphone mixer 1: Mute, 0: No mute (ON)
	14	L2S	1	Mute LINE path to speaker mixer 1: Mute, 0: No mute (ON)
	13	L2M	1	Mute LINE path to mono mixer 1: Mute, 0: No mute (ON)
	12:8	LINEL VOL	01000 (0dB)	LINEL input gain 00000: +12dB ... (1.5dB steps) 11111: -34.5dB
	4:0	LINER VOL	01000 (0dB)	LINER input gain similar to LINELVOL

Table 22 Line Input Control

Additionally, line inputs can be used as single-ended microphone inputs through the record mux to provide a clickless ALC function by bypassing offset introduced through the microphone pre-amps. Note that the line inputs to the mixers should all be deselected if this input configuration is used.

MICROPHONE INPUT

MICROPHONE PRE-AMPS

There are two microphone pre-amplifiers which can be configured in a variety of ways to accommodate up to 3 selectable differential microphone inputs or 2 differential microphone inputs for stereo or noise cancellation. The microphone input circuit is shown in Figure 12.

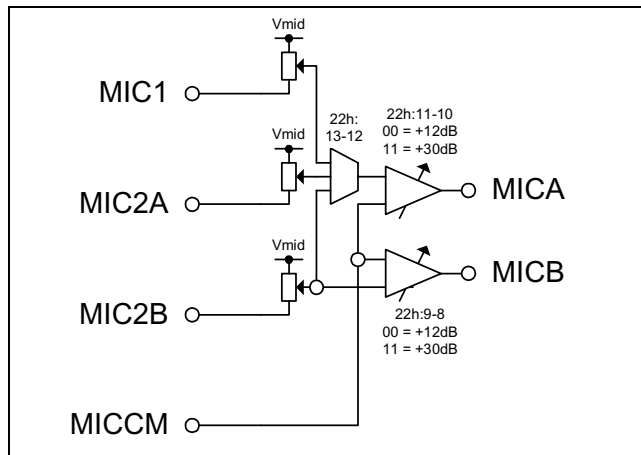

Figure 12 Microphone Input Circuit

The input pins used for the microphones are MIC1, MICCM, MIC2A and MIC2B. Note that input pins MIC2A and MIC2B are multi-function inputs and must be configured for use as microphone inputs when required. This is achieved using MICCMPSEL[1:0] in register 22h (see Table 23). The input to microphone pre-amp A can be selected from any of the three microphone inputs MIC1, MIC2A and MIC2B using MPASEL[1:0]. Each pre-amp has independent boost control from +12dB to +30dB in four steps. This is controlled by MPABST[1:0] and MPBBST[1:0].

When not in use each microphone pre-amp can be powered down using the Powerdown register bits MPA and MPB (register 3Eh, bits [1:0]). When disabled the inputs are tied to Vmid (for MIC2A and MIC2B this only applies when they are selected as microphone inputs, otherwise they are left floating).

REGISTER ADDRESS	BIT	LABEL	DEFAULT	DESCRIPTION
22h	15:14	MICCMPSEL	00	MIC2A and MIC2B pin configuration 00: MIC2A and MIC2B microphone inputs 01: MIC2A only 10: MIC2B only 11: neither
	13:12	MPASEL	00	MICA pre-amp input select 00 : MIC1 01 : MIC2A 10 : MIC2B 11 : unused (do not select)
	11:10	MPABST	00	MICA pre-amp gain control 00 : +12dB 01 : +18dB 10 : +24dB 11 : +30dB
	9:8	MPBBST	00	MICB pre-amp gain control 00 = +12dB 01 = +18dB 10 = +24dB 11 = +30dB

Table 23 Microphone Pre-amp Control

SINGLE MIC OPERATION

Up to three microphones can be connected in a single-ended configuration. Any one of the three MICs can be selected as the input to MPA using MPASEL[1:0] (Register 22h, bits 13:12). Only the microphone on MIC2B can be selected to MPB. Note that MPABST always sets the gain for the selected MPA input microphone. If MIC2B is the selected input for MPA it is recommended that MPB is disabled.

DUAL MIC OPERATION

Up to two microphones can be connected in a dual differential configuration. This is suitable for stereo microphone or noise cancellation applications. Mic1 is connected between the MIC2A and MICCM inputs and mic2 is connected between the MIC2B and MICCM inputs as shown in Figure 13. Additionally, another microphone can be supported on MIC1 selected through the MPA input mux. Note that the microphones can be connected in a single-ended configuration.

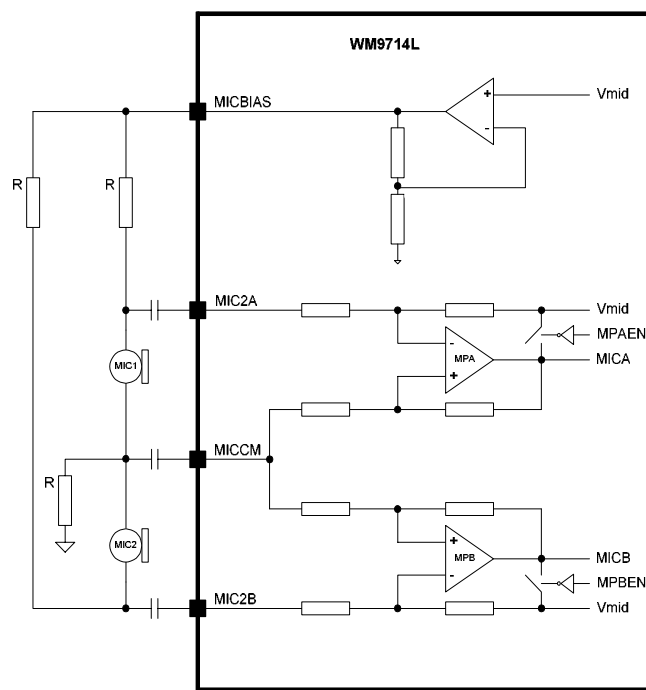

Figure 13 Dual Microphone Configuration

MICROPHONE BIASING CIRCUIT

The MICBIAS output provides a low noise reference voltage suitable for biasing electret type microphones and the associated external resistor biasing network. Refer to the Applications Information section for recommended external components. The MICBIAS voltage can be altered via MBVOL in register 22h. When MBVOL=0, MICBIAS=0.9*AVDD and when MBVOL=1, MICBIAS=0.75*AVDD.

The microphone bias is driven to a dedicated MICBIAS pin 28 and is enabled by MPOP1EN in register 22h. It can also be configured to drive out on GPIO8 pin 12 enabled by MPOP2EN in register 22h.

When not in use the microphone bias can be powered down using the Powerdown register bit MICBIAS (register 3Eh, bit 14).

REGISTER ADDRESS	BIT	LABEL	DEFAULT	DESCRIPTION
22h	7	MBOP2EN	0 (Off)	Microphone bias enable to GPIO8 (pin 12)
	6	MBOP1EN	0 (Off)	Microphone bias enable to MICBIAS (pin 28)
	5	MBVOL	0	Microphone bias voltage control 0: 0.9 * AVDD 1: 0.75 * AVDD

Table 24 Microphone Bias Voltage Control

The internal MICBIAS circuitry is shown in Figure 14. Note that the maximum source current capability for MICBIAS is 3mA. The external biasing resistors therefore must be large enough to limit the MICBIAS current to 3mA.

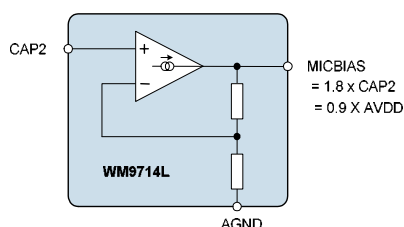

Figure 14 Microphone Bias Schematic

MICBIAS CURRENT DETECT

The WM9714L includes a microphone bias current detect circuit which allows the user to set thresholds for the microphone bias current, above which an interrupt will be triggered. There are two separate interrupt bits, MICDET to allow the user to e.g. distinguish between one or two microphones connected to the WM9714L, and MICSHT to detect a shorted microphone (mic button press). The microphone current detect threshold is set by MCDTHR[2:0], for MICDET, and MCDSCTHR[1:0] for MICSHT. Thresholds for each code are shown in Table 25

When not in use the microphone bias current detect circuit can be powered down using the Powerdown register bit MCD (register 3Eh, bit 15).

See the GPIO and Interrupt Controller sections for details on the interrupt and status readback for the microphone bias current detect & microphone short circuit detect.

REGISTER ADDRESS	BIT	LABEL	DEFAULT	DESCRIPTION
22h	4:2	MCDTHR	000	Mic current detect threshold 000:100uA 001:200uA ... 100uA steps up to 111:800uA These values are for 3.3V supply and scale with supply voltage (AVDD).
	1:0	MCDSCCTR	00	Mic current detect short circuit threshold 00: 600uA 01: 1200uA 10: 1800uA 11: 2400uA These values are for 3.3V supply and scale with supply voltage (AVDD).

Table 25 Microphone Current Detect Control

MICROPHONE PGAS

The microphone pre-amps MPA and MPB drive into two microphone PGAs whose gain is controlled by register 0Eh. The PGA signals can be routed into the headphone mixers and the mono mixer, but not the speaker mixer (to prevent forming a feedback loop) controlled by register 10h. When the PGA signals are not selected as an input to any of the mixers the outputs of the PGAs are muted automatically.

When not in use the microphone PGAs can be powered down using the Powerdown register bits MA and MB (register 3Eh, bits [3:2]).

REGISTER ADDRESS	BIT	LABEL	DEFAULT	DESCRIPTION
0Eh Mic PGA Volume	12:8	MICAVOL	01000 (0dB)	MICA input gain 00000: +12dB ... (1.5dB steps) 11111: -34.5dB
	4:0	MICBVOL	01000 (0dB)	MICB input gain 00000: +12dB ... (1.5dB steps) 11111: -34.5dB

Table 26 Microphone PGA Volume Control

REGISTER ADDRESS	BIT	LABEL	DEFAULT	DESCRIPTION
10h MIC Routing	7	MA2M	1	Mute MICA path to mono mixer 1: Mute, 0: No mute (ON)
	6	MB2M	1	Mute MICB path to mono mixer 1: Mute, 0: No mute (ON)
	5	MIC2MBST	0	Mic to mono mixer boost 0: 0dB, 1: +20dB
	4:3	MIC2H	11	Mic to headphone mixers select 00: MICA and MICB 01: MICA only 10: MICB only 11: none (mutes microphone PGAs)
	2:0	MIC2HVOL	010 (0dB)	Mic PGA to headphone mixers gain 000: +6dB ... (3dB steps) 111: -15dB

Table 27 Microphone PGA Routing Control

MONOIN INPUT

Pin 20 (MONOIN) is a mono input designed to connect to the receive path of a telephony device. The pin connects directly to the record selector for phone call recording (Note: to record both sides of a phone call, one ADC channel should record the MONOIN signal while the other channel records the MIC signal). The record PGA adjusts the recording volume, and is controlled by register 12h or by the ALC function (see "Record Gain" and "Automatic Level Control" sections).

REGISTER ADDRESS	BIT	LABEL	DEFAULT	DESCRIPTION
14h Record Routing	15:14	R2H	11 (mute)	Controls record mux to headphone mixer paths. 00=stereo, 01=left rec mux only, 10=right rec mux only, 11=mute left and right
	13:11	R2HVOL	010 (0dB)	Controls gain of record mux l/r to headphone mixer paths 000: +6dB ... (3dB steps) 111: -15dB
	10:9	R2M	11 (mute)	Controls record mux to mono mixer path. 00=stereo, 01=left rec mux only, 10=right rec mux only, 11=mute left and right
	8	R2MBST	0 (OFF)	Enables 20dB gain boost for record mux to mono mixer path

Table 28 Record PGA Routing Control

To listen to the MONOIN signal, the signal passes through a separate PGA, controlled by register 08h. The signal can be routed into the headphone mixer (for normal phone call operation) and/or the speaker mixer (for speakerphone operation), but not into the mono mixer (to prevent forming a feedback loop). When the signal is not selected as an input to any of the mixers the output of the PGA is muted automatically.

When not in use the MONOIN PGA can be powered down using the Powerdown register bit MOIN (register 3Eh, bit 4).

MONOIN is biased internally to the reference voltage VREF. Whenever the input is muted or the device placed into standby mode, the input remains biased to VREF using special anti-thump circuitry to suppress any audible clicks when changing inputs.

REGISTER ADDRESS	BIT	LABEL	DEFAULT	DESCRIPTION
08h MONOIN PGA Vol / Routing	15	M2H	1	Mute MONOIN path to headphone mixer 1: Mute, 0: No mute (ON)
	14	M2S	1	Mute MONOIN path to speaker mixer 1: Mute, 0: No mute (ON)
	12:8	MONOIN VOL	01000 (0dB)	MONOIN input gain 00000: +12dB ... (1.5dB steps) 11111: -34.5dB

Table 29 Mono PGA Control

PCBEEP INPUT

Pin 19 (PCBEEP) is a mono, line level input intended for externally generated signal or warning tones. It is routed directly to the record selector and all three output mixers, without an input amplifier. The signal gain into each mixer can be independently controlled, with a separate mute bit for each signal path.

PCBEEP is biased internally to the reference voltage VREF. When the signal is not selected as an input to any of the mixers the input remains biased to VREF using special anti-thump circuitry to suppress any audible clicks when changing inputs.

REGISTER ADDRESS	BIT	LABEL	DEFAULT	DESCRIPTION
16h PCBEEP input	15	B2H	1	Mute PCBEEP path to headphone mixer 1: Mute, 0: No mute (ON)
	14:12	B2HVOL	010 (0dB)	PCBEEP to headphone mixer gain 000: +6dB ... (3dB steps) 111: -15dB
	11	B2S	1	Mute PCBEEP path to speaker mixer 1: Mute, 0: No mute (ON)
	10:8	B2SVOL	010 (0dB)	PCBEEP to speaker mixer gain 000: +6dB ... (3dB steps) 111: -15dB
	7	B2M	1	Mute PCBEEP path to mono mixer 1: Mute, 0: No mute (ON)
	6:4	B2MVOL	010 (0dB)	PCBEEP to mono mixer gain 000: +6dB ... (3dB steps) 111: -15dB

Table 30 PCBEEP Control

DIFFERENTIAL MONO INPUT

PCBEEP and MONOIN inputs can be configured to provide a differential mono input. This is achieved by mixing the two inputs together using the headphone mixers or the speaker mixer. Note that the gain of the MONOIN PGA must match the gain of the PCBEEP mixer input to achieve a balanced differential mono input.

AUDIO MIXERS

MIXER OVERVIEW

The WM9714L has four separate low-power audio mixers to cover all audio functions required by smartphones, PDAs and handheld computers. These mixers are used to drive the audio outputs HPL, HPR, MONO, SPKL, SPKR, OUT3 and OUT4. There are also two inverters used to provide complementary output driver signals.

HEADPHONE MIXERS

There are two headphone mixers, headphone mixer left and headphone mixer right (HPMIXL and HPMIXR). These mixers are the stereo output driver source. They are used to drive the stereo outputs HPL and HPR. They can also be used to drive SPKL and SPKR outputs and, when used in conjunction with OUT3 and OUT4, they can be configured to drive complementary signals through the two output inverters to support bridge-tied load (BTL) stereo loudspeaker outputs. The following signals can be mixed into the headphone path:

- MONOIN (controlled by register 08h, see "Audio Inputs")
- LINEL/R (controlled by register 0Ah, see "Audio Inputs")
- the output of the Record PGA (controlled by register 14h, see "Audio ADC", "Record Gain")
- the stereo DAC signal (controlled by register 0Ch, see "Audio DACs")
- the MIC signal (controlled by register 10h, see "Audio Inputs")
- PC_BEEP (controlled by register 16h, see "Audio Inputs")
- the VXDAC signal (controlled by register 18h, see "Audio DACs")
- the AUXDAC signal (controlled by register 1Ah, see "Auxiliary DAC")

In a typical smartphone application, the headphone signal is a mix of MONOIN / VXDAC and sidetone (for phone calls) and the stereo DAC signal (for music playback).

When not in use the headphone mixers can be powered down using the Powerdown register bits HPLX and HPRX (register 3Ch, bits [3:2]).

SPEAKER MIXER

The speaker mixer (SPKMIX) is a mono source. It is typically used to drive a mono loudspeaker in BTL configuration. The following signals can be mixed into the speaker path:

- MONOIN (controlled by register 08h, see "Audio Inputs")
- LINEL/R (controlled by register 0Ah, see "Audio Inputs")
- the stereo DAC signal (controlled by register 0Ch, see "Audio DACs")
- PC_BEEP (controlled by register 16h, see "Audio Inputs")
- the VXDAC signal (controlled by register 18h, see "Audio DACs")
- the AUXDAC signal (controlled by register 1Ah, see "Auxiliary DAC")

In a typical smartphone application, the speaker signal is a mix of AUXDAC (for system alerts or ring tone playback), MONOIN / VXDAC (for speakerphone function), and PC_BEEP (for externally generated ring tones).

Note that when selected the stereo input pairs LINEL/R and DACL/R are summed and attenuated by -6dB so that 0dBFS signals on each channel sum to give a stereo mixed 0dBFS output.

When not in use the speaker mixer can be powered down using the Powerdown register bit SPKX (register 3Ch, bit 1).

MONO MIXER

The mono mixer drives the MONO pin. The following signals can be mixed into MONO:

- LINEL/R (controlled by register 0Ah, see "Audio Inputs")
- the output of the Record PGA (controlled by register 14h, see "Audio ADC", "Record Gain")
- the stereo DAC signal (controlled by register 0Ch, see "Audio DACs")
- the MIC signal (controlled by register 10h, see "Audio Inputs")
- PC_BEEP (controlled by register 16h, see "Audio Inputs")
- the VXDAC signal (controlled by register 18h, see "Audio DACs")
- the AUXDAC signal (controlled by register 12h, see "Auxiliary DAC")

In a typical smartphone application, the MONO signal is a mix of the amplified microphone signal (possibly with Automatic Gain Control) and (if enabled) an audio playback signal from the stereo DAC or the auxiliary DAC.

Note that when selected the stereo input pairs LINEL/R and DACL/R are summed and attenuated by -6dB so that 0dBFS signals on each channel sum to give a stereo mixed 0dBFS output.

When not in use the mono mixer can be powered down using the Powerdown register bit MX (register 3Ch, bit 0).

MIXER OUTPUT INVERTERS

There are two general purpose mixer output inverters, INV1 and INV2. Each inverter can be selected to drive HPMIXL, HPMIXR, SPKMIX, MONOMIX or { (HPMIXL + HPMIXR) / 2 }. The outputs of the inverters can be used to generate complimentary signals (to drive BTL configured loads) and to provide greater flexibility in output driver configurations. INV1 can be selected as the source for SPKL, MONO and OUT3 and INV2 as the source for SPKR and OUT4.

The input source for each inverter is selected using INV1[2:0] and INV2[2:0] in register 1Eh (see Table 31). When no input is selected the inverter is powered down.

REGISTER ADDRESS	BIT	LABEL	DEFAULT	DESCRIPTION
1Eh	15:13	INV1	000 (OFF)	INV1 source select 000: Z _H (OFF – no source selected) 001: MONOMIX 010: SPKMIX 011: HPMIXL 100: HPMIXR 101: HPMIXMONO 110: unused 111: Vmid
	12:10	INV2	000 (OFF)	INV2 source select Same as INV1

Table 31 Mixer Inverter Source Select

ANALOGUE AUDIO OUTPUTS

The following sections give an overview of the analogue audio output pins. The WM9714L has three outputs capable of driving loads down to 16Ω (headphone / line drivers) – HPL, HPR and MONO - and four output capable of driving loads down to 8Ω (loudspeaker / line drivers) – SPKL, SPKR, OUT3 and OUT4. The combination of output drivers, mixers and mixer inverters means that many output configurations can be supported.

For examples of typical output and mixer configurations please refer to the "Typical Output Configurations" section. For more information on recommended external components, please refer to the "Applications Information" section.

Each output is driven by a PGA with a gain range of 0dB to -46.5dB in -1.5dB steps. Each PGA has an input source mux, mute and zero-cross detect circuit (delaying gain changes until a zero-cross is detected, or after time-out).

HEADPHONE OUTPUTS – HPL AND HPR

The HPL and HPR outputs (pins 39 and 41) are designed to drive a 16Ω or 32Ω headphone load. They can also be used as line outputs. They can be used in and AC coupled or DC coupled (capless) configuration. The available input sources are HPMIXL/R and Vmid (see Table 32).

REGISTER ADDRESS	BIT	LABEL	DEFAULT	DESCRIPTION
1Ch Output PGA Mux Select	7:6	HPL	00 (Vmid)	HPL input source select 00: Vmid 01: no i/p (Z _H if buffer disabled) 10: HPMIXL 11: unused
	5:4	HPR	00 (Vmid)	HPR input source select 00: Vmid 01: no i/p (Z _H if buffer disabled) 10: HPMIXR 11: unused

Table 32 HPL / HPR PGA Input Source

The signal volume on HPL and HPR can be independently adjusted under software control by writing to register 04h.

When not in use HPL and HPR can be powered down using the Powerdown register bits HPL and HPR (register 3Eh, bits [10:9]). To minimise pops and clicks when the PGA is powered down / up it is recommended that the Vmid input is selected during the power down / up cycle. This ensures the same DC level is maintained on the output pin throughout.

REGISTER ADDRESS	BIT	LABEL	DEFAULT	DESCRIPTION
04h Headphone Volume	15	MUL	1 (Mute)	Mute HPL 1: Mute (OFF) 0: No Mute (ON)
	14	ZCL	0	Left zero cross enable 0: Change gain immediately 1: Change gain only on zero crossings, or after time-out
	13:8	HPLVOL	000000 (0dB)	HPL Volume 000000: 0dB (maximum) 000001: -1.5dB ... (1.5dB steps) 011111: -46.5dB 1xxxxx: -46.5dB
	7	MUR	1 (Mute)	Mute HPR 1: Mute (OFF) 0: No Mute (ON)
	6	ZCR	0	Right zero cross enable 0: Change gain immediately 1: Change gain only on zero crossings, or after time-out
	5:0	HPRVOL	00000 (0dB)	HPR Volume Similar to HPLVOL

Table 33 HPL / HPR PGA Control

MONO OUTPUT

The MONO output (pin 31) is designed to drive a 16Ω headphone load and can also be used as a line outputs. The available input sources are MONOMIX, INV1 and Vmid (see Table 34)

REGISTER ADDRESS	BIT	LABEL	DEFAULT	DESCRIPTION
1Ch Output PGA Mux Select	15:14	MONO	00 (Vmid)	MONO input source select 00: Vmid 01: no i/p (Z _H if buffer disabled) 10: MONOMIX 11: INV1

Table 34 MONO PGA Input Source

The signal volume on MONO can be independently adjusted under software control by writing to register 08h.

When not in use MONO can be powered down using the Powerdown register bit MONO (register 3Eh, bit 13). To minimise pops and clicks when the PGA is powered down / up it is recommended that the Vmid input is selected during the power down / up cycle. This ensures the same DC level is maintained on the output pin throughout.

REGISTER ADDRESS	BIT	LABEL	DEFAULT	DESCRIPTION
08h MONO Vol	7	MU	1 (Mute)	Mute MONO 1: Mute (OFF) 0: No Mute (ON)
	6	ZC	0	Right zero cross enable 0: Change gain immediately 1: Change gain only on zero crossings, or after time-out
	5:0	MONOVOL	000000 (0dB)	MONO Volume 000000: 0dB (maximum) 000001: -1.5dB ... (1.5dB steps) 011111: -46.5dB 1xxxxx: -46.5dB

Table 35 Mono PGA Control

SPEAKER OUTPUTS – SPKL AND SPKR

The SPKL and SPKR (pins 35 and 36) are designed to drive a loudspeaker load down to 8Ω and can also be used as line outputs and headphone outputs. They are designed to drive an 8Ω load AC coupled or in a BTL (capless) configuration. The available input sources are HPMIXL/R, SPKMIXL/R, INV1/2 and Vmid (see Table 36).

REGISTER ADDRESS	BIT	LABEL	DEFAULT	DESCRIPTION
1Ch Output PGA Mux Select	13:11	SPKL	000 (Vmid)	SPKL input source select 000: Vmid 001: no i/p (Z _H if buffer disabled) 010: HPMIXL 011: SPKMIX 100: INV1 101-111: unused
	10:8	SPKR	000 (Vmid)	SPKR input source select 000: Vmid 001: no i/p (Z _H if buffer disabled) 010: HPMIXR 011: SPKMIX 100: INV2 101-111: unused

Table 36 SPKL / SPKR PGA Input Source

The signal volume on SPKL and SPKR can be independently adjusted under software control by writing to register 02h.

When not in use SPKL and SPKR can be powered down using the Powerdown register bits SPKL and SPKR (register 3Eh, bits [8:7]). To minimise pops and clicks when the PGA is powered down / up it is recommended that the Vmid input is selected during the power down / up cycle. This ensures the same DC level is maintained on the output pin throughout.

REGISTER ADDRESS	BIT	LABEL	DEFAULT	DESCRIPTION
02h Speaker Volume	15	MUL	1 (Mute)	Mute SPKL 1: Mute (OFF) 0: No Mute (ON)
	14	ZCL	0	Left zero cross enable 0: Change gain immediately 1: Change gain only on zero crossings, or after time-out
	13:8	SPKLVOL	000000 (0dB)	SPKL Volume 000000: 0dB (maximum) 000001: -1.5dB ... (1.5dB steps) 011111: -46.5dB 1xxxxx: -46.5dB
	7	MUR	1 (Mute)	Mute SPKR 1: Mute (OFF) 0: No Mute (ON)
	6	ZCR	0	Right zero cross enable 0: Change gain immediately 1: Change gain only on zero crossings, or after time-out
	5:0	SPKRVOL	00000 (0dB)	SPKR Volume Similar to SPKLVOL

Table 37 SPKL / SPKR PGA Control

Note:

- For BTL speaker drive, it is recommended that both PGAs have the same gain setting.

AUXILLARY OUTPUTS – OUT3 AND OUT4

The OUT3 and OUT4 outputs (pins 37 and 33) are designed to drive a loudspeaker load down to 8Ω and can also be used as line outputs and headphone outputs. They are designed to drive an 8Ω load AC coupled or in a BTL (capless) configuration and can be used as a midrail buffer to drive the headphone outputs in a capless DC configuration. The available input sources are INV1/2 and Vmid (see Table 38).

REGISTER ADDRESS	BIT	LABEL	DEFAULT	DESCRIPTION
1Ch Output PGA Mux Select	3:2	OUT3	00 (Vmid)	OUT3 input source select 00: Vmid 01: no i/p (Z _H if buffer disabled) 10: INV1 11: unused
	1:0	OUT4	00 (Vmid)	OUT4 input source select 00: Vmid 01: no i/p (Z _H if buffer disabled) 10: INV2 11: unused

Table 38 OUT3 / OUT4 PGA Input Source

The signal volume on OUT3 and OUT4 can be independently adjusted under software control by writing to register 06h.

When not in use OUT3 and OUT4 can be powered down using the Powerdown register bits OUT3 and OUT4 (register 3Eh, bits [11:12]). To minimise pops and clicks when the PGA is powered down / up it is recommended that the Vmid input is selected during the power down / up cycle. This ensures the same DC level is maintained on the output pin throughout.

REGISTER ADDRESS	BIT	LABEL	DEFAULT	DESCRIPTION
06h Speaker Volume	15	MU4	1 (Mute)	Mute OUT4 1: Mute (OFF) 0: No Mute (ON)
	14	ZC4	0	OUT4 zero cross enable 0: Change gain immediately 1: Change gain only on zero crossings, or after time-out
	13:8	OUT4VOL	000000 (0dB)	OUT4 Volume 000000: 0dB (maximum) 000001: -1.5dB ... (1.5dB steps) 011111: -46.5dB 1xxxxx: -46.5dB
	7	MU3	1 (Mute)	Mute OUT3 1: Mute (OFF) 0: No Mute (ON)
	6	ZC3	0	OUT3 zero cross enable 0: Change gain immediately 1: Change gain only on zero crossings, or after time-out
	5:0	OUT3VOL	00000 (0dB)	OUT3 Volume Similar to OUT4VOL

Table 39 OUT3 / OUT4 PGA Control

THERMAL SENSOR

The speaker and headphone outputs can drive very large currents. To protect the WM9714L from becoming too hot, a thermal sensor has been built in. If the chip temperature reaches approximately 150°C, and the ENT bit is set, the WM9714L deasserts GPIO bit 11 in register 54h, a virtual GPIO that can be set up to generate an interrupt to the CPU (see “GPIO and Interrupt Control” section).

REGISTER ADDRESS	BIT	LABEL	DEFAULT	DESCRIPTION
3Ch	13	TSHUT	1	Power down thermal sensor 0: Enabled 1: Disabled
54h	11	TI	0	Thermal sensor (virtual GPIO) 1: Temperature below 150°C 0: Temperature above 150°C See also “GPIO and Interrupt Control” section.

Table 40 Thermal Cutout Control

JACK INSERTION AND AUTO-SWITCHING

In a phone application, a BTL ear speaker may be connected across MONO and HPL, a stereo headphone on HPL and HPR and stereo speakers on SPKL, SPKR, OUT3 and OUT4 (see Figure 15). Typically, only one of these three output devices is used at any given time: when no headphone is plugged in, the BTL ear speaker or stereo speakers are active, otherwise the headphone is used.

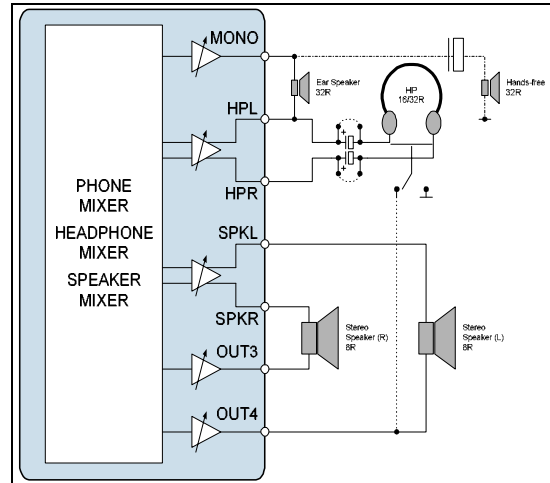

Figure 15 Typical Output Configuration

The presence of a headphone can be detected using one of GPIO1/6/7/8 (pins 44, 3, 11 & 12) and an external pull-up resistor (see “Applications Information” section for a circuit diagram). When the jack is inserted the GPIO is pulled low by a switch on the socket. When the jack is removed the GPIO is pulled high by a resistor. If the JIEN bit is set, the WM9714L automatically switches between headphone and any other output configuration, typically ear speaker or stereo speaker that has been set up in the Powerdown and Output PGA Mux Select registers.

Note: The GPIO polarity can be inverted by setting register 4Eh.

In addition to the typical configuration explained above the WM9714L can also support automatic switching between the following three configurations set as BTL ear speaker and headphone.

REGISTER ADDRESS	BIT	LABEL	DEFAULT	DESCRIPTION
24h Output Volume Mapping (Jack Insert)	1:0	EARSPKSEL	00	00: Default, no ear speaker configuration selected. 01: MONO and HPL driver selected as BTL ear speaker. 10: OUT3 and HPL driver selected as BTL ear speaker. 11: OUT4 and HPL driver selected as BTL ear speaker.

Table 41 Ear Speaker Configuration

For example if OUT4 and HPL is selected as the BTL ear speaker, the user should select EARSPKSEL = 3h, then OUT4 is tri-stated on jack insert to prevent sound across the ear speaker during headphone operation and HPL volume is set to OUT4 volume on jack out to ensure correct ear speaker operation. It should be noted that all other outputs except HPL, HPR and selected ear speaker driver are disabled and internally connected to VREF on jack insert. This maintains VREF at those outputs and helps prevent pops when the outputs are enabled.

Finally if the user wishes to DC couple the headphone outputs the user needs to select between OUT3 and OUT4 as the mid-rail output buffer driver. The selected mid-rail output buffer is enabled on jack insert. On jack out it defaults to whatever configuration has been set up in the Powerdown and Output PGA Mux Select registers.

REGISTER ADDRESS	BIT	LABEL	DEFAULT	DESCRIPTION
24h Output Volume Mapping (Jack Insert)	3:2	DCDRVSEL	00	00: Default, AC coupled headphone. 01: OUT4 as mid-rail output buffer. 11: OUT3 as mid-rail output buffer.

Table 42 DC Coupled Headphone Configuration

In summary:

JIEN not set: Outputs work as normal as selected in the Powerdown and Output PGA Mux Select registers.

JIEN set: On jack insert GPIO1/6/7/8 is pulled low, HPL and HPR are enabled, DCDRVSEL decides if the headphones are DC or AC coupled and configures OUT3 or OUT4 to suit, EARSPKSEL decides if MONO, OUT3 or OUT4 need to be tri-stated to ensure no sound out on the ear-speaker and finally all other outputs are disabled as explained above to prevent pops on re-enabling.

On jack out GPIO1/6/7/8 is pulled high, the outputs work as normal as selected in the Powerdown and Output PGA Mux Select registers except that HPL Volume is controlled by EARSPKSEL to ensure correct ear speaker operation.

REGISTER ADDRESS	BIT	LABEL	DEFAULT	DESCRIPTION
24h Output Volume Mapping (Jack Insert)	4	JIEN	0 (OFF)	Jack Insert Enable – Takes output of GPIO1 logic
5Ah Additional Functions (1)	7:6	JSEL	00 (GPIO1)	GPIO select for jack insert detection: 00: GPIO1 01: GPIO6 10: GPIO7 11: GPIO8

Table 43 Jack Insertion / Auto-Switching (1)

J1EN	EARSPEL	DCDRSEL	GPIO1	MODE DESCRIPTION	HPL STATE	HPL VOLUME	HPR STATE	HPR VOLUME	MONO STATE	OUT3 STATE	OUT4 STATE	SPKL STATE	SPKR STATE
0	XX	XX	X	Jack Insert Detection Disabled.	User Controlled	User Controlled	User Controlled	User Controlled	User Controlled	User Controlled	User Controlled	User Controlled	User Controlled
1	00	00	0	Jack Insert Detection Enabled. Headphone plugged in. No Ear Speaker Selected. AC Coupled Headphone Selected.	Enabled	HPL Volume	Enabled	HPR Volume	HZ	HZ	HZ	HZ	HZ
1	01	00	0	Jack Insert Detection Enabled. Headphone plugged in. MONO Ear Speaker Selected. AC Coupled Headphone Selected.	Enabled	HPL Volume	Enabled	HPR Volume	Tri-States	HZ	HZ	HZ	HZ
1	10	00	0	Jack Insert Detection Enabled. Headphone plugged in. OUT3 Ear Speaker Selected. AC Coupled Headphone Selected.	Enabled	HPL Volume	Enabled	HPR Volume	HZ	Tri-States	HZ	HZ	HZ
1	11	00	0	Jack Insert Detection Enabled. Headphone plugged in. OUT4 Ear Speaker Selected. AC Coupled Headphone Selected.	Enabled	HPL Volume	Enabled	HPR Volume	HZ	HZ	Tri-States	HZ	HZ
1	11	01	0	Jack Insert Detection Enabled. Headphone plugged in. OUT4 Ear Speaker Selected. OUT3 DC Coupled Headphone Selected.	Enabled	HPL Volume	Enabled	HPR Volume	HZ	VMID	Tri-States	HZ	HZ
1	00	XX	1	Jack Insert Detection Enabled. Headphone plugged out. No Ear Speaker Selected.	User Controlled	User Controlled	User Controlled	User Controlled	User Controlled	User Controlled	User Controlled	User Controlled	User Controlled
1	11	XX	1	Jack Insert Detection Enabled. Headphone plugged out. OUT4 Ear Speaker Selected.	User Controlled	OUT4 Volume	User Controlled	User Controlled	User Controlled	User Controlled	User Controlled	User Controlled	User Controlled

Table 44 Jack Insertion / Auto-Switching (2)

DIGITAL AUDIO (SPDIF) OUTPUT

The WM9714L supports the SPDIF standard. Pins 48 & 12 can be used to output the SPDIF data. Note that pins 48 & 12 can also be used as GPIO pins. The GE5 & GE8 bits (register 56h, bit 5 & bit 8) select between GPIO and SPDIF functionality for pins 48 & 12 respectively (see "GPIO and Interrupt control" section).

Register 3Ah is a read/write register that controls SPDIF functionality and manages bit fields propagated as channel status (or sub-frame in the V case). With the exception of V, this register should only be written to when the SPDIF transmitter is disabled (SPDIF bit in register 2Ah is '0'). Once the desired values have been written to this register, the contents should be read back to ensure that the sample rate in particular is supported, then SPDIF validity bit SPCV in register 2Ah should be read to ensure the desired configuration is valid. Only then should the SPDIF enable bit in register 2Ah be set. This ensures that control and status information start up correctly at the beginning of SPDIF transmission.

REGISTER ADDRESS	BIT	LABEL	DEFAULT	DESCRIPTION
2Ah Extended Audio	10	SPCV	0	SPDIF validity bit (read-only)
	5:4	SPSA	01	SPDIF slot assignment (ADCO = 0) 00: Slots 3, 4 01: Slots 6, 9 10: Slots 7, 8 11: Slots 10, 11
	2	SEN	0	SPDIF output enable 1 = enabled, 0 = disabled
3Ah SPDIF Control Register	15	V	0	Validity bit; '0' indicates frame valid, '1' indicates frame not valid
	14	DRS	0	Indicates that the WM9714L does not support double rate SPDIF output (read-only)
	13:12	SPSR	10	Indicates that the WM9714L only supports 48kHz sampling on the SPDIF output (read-only)
	11	L	0	Generation level; programmed as required by user
	10:4	CC	0000000	Category code; programmed as required by user
	3	PRE	0	Pre-emphasis; '0' indicates no pre-emphasis, '1' indicates 50/15us pre-emphasis
	2	COPY	0	Copyright; '0' indicates copyright is not asserted, '1' indicates copyright
	1	AUDIB	0	Non-audio; '0' indicates data is PCM, '1' indicates non-PCM format (e.g. DD or DTS)
5Ch Additional Function Control	4	ADCO	0	Source of SPDIF data 0: SPDIF data comes from SDATAOUT (pin 5), slot selected by SPSA 1: SPDIF data comes from audio ADC

Table 45 SPDIF Output Control

AUX ADC

The WM9714L includes a very low power, 12-bit successive approximation type ADC which can be used for battery and auxiliary measurements.

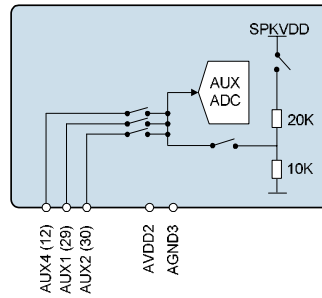

Figure 16 AUX ADC Switch Matrix

The AUX ADC is accessed and controlled through the AC-Link interface.

POWER MANAGEMENT

To save power, the AUX ADC can be independently disabled when not used.

The AUX ADC is powered-down using PADCPD, register 3Ch bit 15.

The state of the ADC is controlled by the following bits.

REGISTER ADDRESS	BIT	LABEL	DEFAULT	DESCRIPTION
3Ch	15	PADCPD	1 = off	AUX ADC power down
78h	15:14	PRP	00	AUX ADC enable 00 – Pen digitiser off, pen detect off, no wake-up on pen down (default) 01 – NOT USED 10 – NOT USED 11 – AUX ADC enabled

Table 46 ADC Control (Power Management)

INITIATION OF MEASUREMENTS

The WM9714L ADC interface supports both polling routines and DMA (direct memory access) to control the flow of data from the AUX ADC to the host CPU.

In a polling routine, the CPU starts each measurement individually by writing to the POLL bit (register 74h, bit 9). This bit automatically resets itself when the measurement is completed.

REGISTER ADDRESS	BIT	LABEL	DEFAULT	DESCRIPTION
74h	9	POLL	0	Writing "1" initiates a measurement. (when CTC is not set)
	8	CTC	0	0: Polling mode 1: Continuous mode (for DMA)
76h	9:8	CR	00	Continuous mode rate (DEL = 1111) 00: 93.75 Hz (every 512 AC-Link frames) 01: 120 Hz (every 400 AC-Link frames) 10: 153.75 Hz (every 312 AC-Link frames) 11: 187.5Hz (every 256 AC-Link frames) Continuous mode "fast rate" (DEL = 1111) 00: 8 kHz (every six AC-Link frames) 01: 12 kHz (every four AC-Link frames) 10: 24 kHz (every other AC-Link frame) 11: 48 kHz (every AC-Link frame)

Table 47 AUX ADC Control (Initiation of Measurements)

In continuous mode (CTC = 1), the WM9714L autonomously initiates measurements (or sets of measurements) at the rate set by CR, and supplies the measured data to the CPU on one of the unused AC'97 time slots. DMA-enabled CPUs can write the data directly into a FIFO without any intervention by the CPU core. This reduces CPU loading and speeds up the execution of user programs in handheld systems.

Note that the measurement frequency in continuous mode is also affected by the DEL bits. The faster rates achieved when DEL = 1111 may be useful when the ADC is used for multiple measurements.

MEASUREMENT TYPES

The ADCSEL control bits determine which type of measurement is performed (see below).

REGISTER ADDRESS	BIT	LABEL	DEFAULT	DESCRIPTION
74h	9	POLL	0	Writing "1" initiates a measurement. (when CTC is not set)
	8	CTC	0	0: Polling mode 1: Continuous mode (for DMA)
	7	ADCSEL_AUX4	0	Enable COMP1/AUX4 measurement (pin32). NB: Only one of bits[7:4] should be set.
	6	ADCSEL_AUX3	0	Enable COMP1/AUX3 measurement (pin31) . NB: Only one of bits[7:4] should be set.
	5	ADCSEL_AUX2	0	Enable COMP1/AUX2 measurement (pin30) . NB: Only one of bits[7:4] should be set.
	4	ADCSEL_AUX1	0	Enable COMP1/AUX1 measurement (pin29) . NB: Only one of bits[7:4] should be set.

Table 48 AUX ADC Control (Measurement Types)

The WM9714L performs a single measurement – either in polling mode or continuously, as indicated by the CTC bit. The type of measurement is specified by the ADCSEL[7:4] bits. Only one of the ADCSEL[7:4] bits should be set.

CONVERSION RATE

As stated previously the conversion rate is specified by the CR bits (reg 76h).

CR may be set to 93.75Hz (every 512 AC-Link Frames), 120Hz (every 400 AC-Link Frames), 153.75Hz (every 312 AC-Link frames) or 187.5Hz (every 256 AC-Link frames).

If only one ADRSEL[7:1] bit is set then each individual conversion occurs at the rate specified by CR.

If multiple ADRSEL[7:1] bits are set then the complete set of conversions requested is completed at the rate specified by CR.

DATA READBACK

This data is stored in register 7Ah, and can be retrieved by reading the register in the usual manner (see AC-Link Interface section). Additionally, the data can also be passed to the controller on one of the AC-Link time slots not used for audio functions.

The output data word of the AUX ADC interface consists of three parts:

- 1 Unused bit (Ignore).
- Output data from the AUX ADC (12 bits)
- ADCSRC: 3 additional bits that indicate the source of the ADC data.

If the data is being read back using the polling method, there are several ways to determine when a measurement has finished:

- Reading back the POLL bit. If it has been reset to '0', then the measurement has finished.
- Monitoring the ADA signal, see GPIO and interrupt section. ADA goes high after every single conversion.
- Reading back 7Ah until the new data appears

REGISTER ADDRESS	BIT	LABEL	DEFAULT	DESCRIPTION
7Ah or AC-Link slot selected by SLT	14:12	ADC SRC	000	AUX ADC Source 000: No measurement 001: Not used 010: Not used 011: Not used 100: COMP1/AUX1 measurement (pin 29) 101: COMP2/AUX2 measurement (pin 30) 110: BMON/AUX3 measurement (pin 31) 111: Not used
	11:0	ADCD	000h	AUX ADC Data (read-only) Bit 11 = MSB Bit 0 = LSB
78h	9	WAIT	0	0: No effect (new ADC data overwrites unread data in register 7Ah) 1: New data is held back, and measurements delayed, until register 7Ah is read)

Table 49 AUX ADC Data

To avoid losing data that has not yet been read, the WM9714L can delay overwriting register 7Ah with new conversions until the old data has been read. This function is enabled using the WAIT bit.

If the SLEN bit is set to '1', then the ADC data appears on the AC-Link slot selected by the SLT control bits, as shown below. The Slot 0 'tag' bit corresponding to the selected time slot is asserted whenever there is new data on that slot.

REGISTER ADDRESS	BIT	LABEL	DEFAULT	DESCRIPTION
76h	3	SLEN	0	Slot Readback Enable 0: Disabled (readback through register only) 1: Enable (readback slot selected by SLT)
	2:0	SLT	110	AC'97 Slot Selection for AUX ADC Data 000: Slot 5 001: Slot 6 ... 101: Slot 10 110: Slot 11 111: RESERVED

Table 50 Returning AUX ADC Data Through an AC-Link Time Slot

MASK INPUT CONTROL

Sources of glitch noise, such as the signals driving an LCD display, may feed through to the AUX ADC inputs and affect measurement accuracy. In order to minimise this effect, a signal may be applied to MASK (pin 47 / pin 3) to delay or synchronise the sampling of any input to the ADC. The effect of the MASK signal depends on the the MSK bits of register 78h (bits [7:6]), as described below.

REGISTER ADDRESS	BIT	LABEL	DEFAULT	DESCRIPTION
78h	7:6	MSK	00	MASK input control (see Table 52)

Table 51 MASK Input Control

MSK[1-0]	EFFECT OF SIGNAL ON MASK PIN
00	Mask has no effect on conversions GPIO input disabled (default)
01	Static; 'hi' on MASK pin stops conversions, 'lo' has no effect.
10	Edge triggered; rising or falling edge on MASK pin delays conversions by an amount set in the DEL[3-0] register. Conversions are asynchronous to the MASK signal.
11	Synchronous mode; conversions wait until rising or falling edge on MASK initiates cycle; screen starts to be driven when the edge arrives, the conversion sample being taken a period set by DEL[3-0] after the edge.

Table 52 Controlling the MASK Feature

Note that pin 47 / pin 3 can also be used as a GPIO(see "GPIO and Interrupt Control" section), or to output the ADA signal (see below).

THE ADA SIGNAL

Whenever data becomes available from the AUX ADC, the internal ADA (ADC Data Available) signal goes high and remains high until the data has been read from register 7Ah (if SLEN = 0) or until it has been sent out on an AC-Link slot (if SLEN = 1).

ADA goes high after every AUX ADC conversion (in normal mode, COO=0)

ADA can be used to generate an interrupt, if the AW bit (register 52h, bit 12) is set (see "GPIO and interrupt control" section)

It is also possible to output the ADA signal on pin 47 / pin 3, if this pin is not used as a GPIO. The GE4/6 bit must be set to '0' to achieve this (see "GPIO and interrupt control" section).

Alternatively, ADA can be read from bit 12 in register 54h.

ADDITIONAL FEATURES

AUXILIARY ADC INPUTS

The WM9714L has three pins that can be used as auxiliary ADC inputs:

- MIC2A / COMP1 / AUX1 (pin 29)
- MIC2B / COMP2 / AUX2 (pin 30)
- AUX4 (pin 12)

Additionally, the speaker supply (SPKVDD) can be used as an auxiliary ADC input through an on-chip potential divider giving an input to the auxiliary ADC of SPKVDD/3. This input is referred to as the AUX3 input (see Figure 16).

Pins 29 and 30 are also used as comparator inputs (see Battery Alarm and Battery Measurement), but auxiliary measurements can still be taken on these pins at any time. The ADCSEL control bits select between different ADC inputs, as shown in **Error! Reference source not found.**

The ADCSEL control bits determine which type of measurement is performed (see below). When performing auxiliary conversions the co-ordinate mode bit, COO, should be off (0).

BATTERY ALARM AND ANALOGUE COMPARATORS

The battery alarm function differs from battery measurement in that it does not actually measure the battery voltage. Battery alarm only indicates “OK”, “Low” or “Dead”. The advantage of the battery alarm function is that it does not require a clock and can therefore be used in low-power sleep or standby modes.

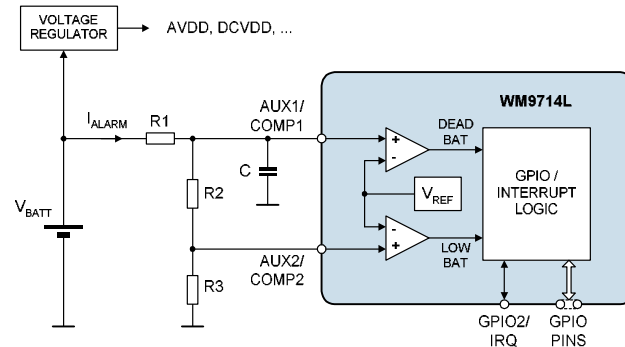

Figure 17 Battery Alarm Example Schematic

The typical schematic for a dual threshold battery alarm is shown above. This alarm has two thresholds, “dead battery” (COMP1) and “low battery” (COMP2). R1, R2 and R3 set the threshold voltages. Their values can be up to about 1M Ω in order to keep the battery current [$I_{ALARM} = V_{BATT} / (R1+R2+R3)$] to a minimum (higher resistor values may affect the accuracy of the system as leakage currents into the input pins become significant).

Dead battery alarm: COMP1 triggers when $V_{BATT} < V_{REF} \times (R1+R2+R3) / (R2+R3)$

A dead battery alarm is the highest priority of interrupt in the system. It should immediately save all unsaved data and shut down the system. The GP15, GS15 and GW15 bits must be set to generate this interrupt.

Low battery alarm: COMP2 triggers when $V_{BATT} < V_{REF} \times (R1+R2+R3) / R3$

A low battery alarm has a lower priority than a dead battery alarm. Since the threshold voltage is higher than for a dead battery alarm, there is enough power left in the battery to give the user a warning and/or shut down “gracefully”. When V_{BATT} gets close to the low battery threshold, spurious alarms are filtered out by the COMP2 delay function.

The purpose of the capacitor C is to remove from the comparator inputs any high frequency noise or glitches that may be present on the battery (for example, noise generated by a charge pump). It forms a low pass filter with R1, R2 and R3.

Low pass cutoff f_c [Hz] = $1 / (2\pi \times C \times (R1 \parallel (R2+R3)))$

Provided that the cutoff frequency is several orders of magnitude lower than the noise frequency f_n , this simple circuit can achieve excellent noise rejection.

Noise rejection [dB] = $20 \log (f_n / f_c)$

The circuit shown above also allows for measuring the battery voltage V_{BATT} . This is achieved simply by setting the AUX ADC input to be either COMP1 (ADCSEL = 100) or COMP2 (ADCSEL = 101) (see also Auxiliary ADC Inputs).

The WM9714L has two on-chip comparators that can be used to implement a battery alarm function, or other functions such as a window comparator. Each comparator has one of its inputs tied to any one of three device pins and the other tied to a voltage reference. The voltage reference can be either internally generated ($V_{REF} = AVDD/2$) or externally connected on AUX4 (pin 12).

The comparator output signals are passed to the GPIO logic block (see "GPIO and Interrupt Control" section), where they can be used to send an interrupt to the CPU via the AC-Link or via the IRQ pin, and / or to wake up the WM9714L from sleep mode. COMP1/AUX1 (pin 29) corresponds to GPIO bit 15 and COMP2/AUX2 (pin 30) to bit 14.

REGISTER ADDRESS	BIT	LABEL	DEFAULT	DESCRIPTION
4Eh	15	CP1	1	COMP1 Polarity (see also "GPIO and Interrupt Control") 0: Alarm when COMP1 voltage is below VREF 1: Alarm when COMP1 voltage is above VREF
	14	CP2	1	COMP1 Polarity (see also "GPIO and Interrupt Control") 0: Alarm when COMP2 voltage is below VREF 1: Alarm when COMP2 voltage is above VREF
5Ah	15:13	COMP2 DEL	000	Low Battery Alarm Delay 000: No delay 001: 0.17s ($2^{13} = 8192$ AC-Link frames) 010: 0.34s ($2^{14} = 16384$ AC-Link frames) 011: 0.68s ($2^{15} = 32768$ AC-Link frames) 100: 1.4s ($2^{16} = 65536$ AC-Link frames) 101: 2.7s ($2^{17} = 131072$ AC-Link frames) 110: 5.5s ($2^{18} = 262144$ AC-Link frames) 111: 10.9s ($2^{19} = 524288$ AC-Link frames)

Table 53 Comparator Control

REGISTER ADDRESS	BIT	LABEL	DEFAULT	DESCRIPTION		
5Ch Additional Analogue Functions	14	C1REF	0	Comparator 1 Reference Voltage		
				0	VREF = AVDD/2	
					1	WIPER/AUX4 (pin 12)
	13:12	C1SRC	00	Comparator 1 Signal Source		
				00	AVDD/2 when C1REF='1'. Otherwise comparator 1 is powered down	
				01	COMP1/AUX1 (pin 29)	
				10	COMP2/AUX2 (pin 30)	
					11	AUX3 (SPKVDD)
	11	C2REF	0	Comparator 2 Reference Voltage		
				0	VREF = AVDD/2	
					1	WIPER/AUX4 (pin 12)
	10:9	C2SRC	00	Comparator 2 Signal Source		
00				AVDD/2 when C2REF='1'. Otherwise comparator 2 is powered down		
01				COMP1/AUX1 (pin 29)		
10				COMP2/AUX2 (pin 30)		
				11	AUX3 (SPKVDD)	

Table 54 Comparator Reference and Source Control

COMP2 DELAY FUNCTION

COMP2 has an optional delay function for use when the input signal is noisy. When COMP2 triggers and the delay is enabled (i.e. COMP2DEL is non-zero), then GPIO bit 14 does not change state immediately, and no interrupt is generated. Instead, the WM9714L starts a delay timer and checks COMP2 again after the delay time has passed. If COMP2 is still active, then the GPIO bit is set and an interrupt may be generated (depending on the state of the GW14 bit). If COMP2 is no longer active, the GPIO bit is not set, i.e. all register bits are as if COMP2 had never triggered.

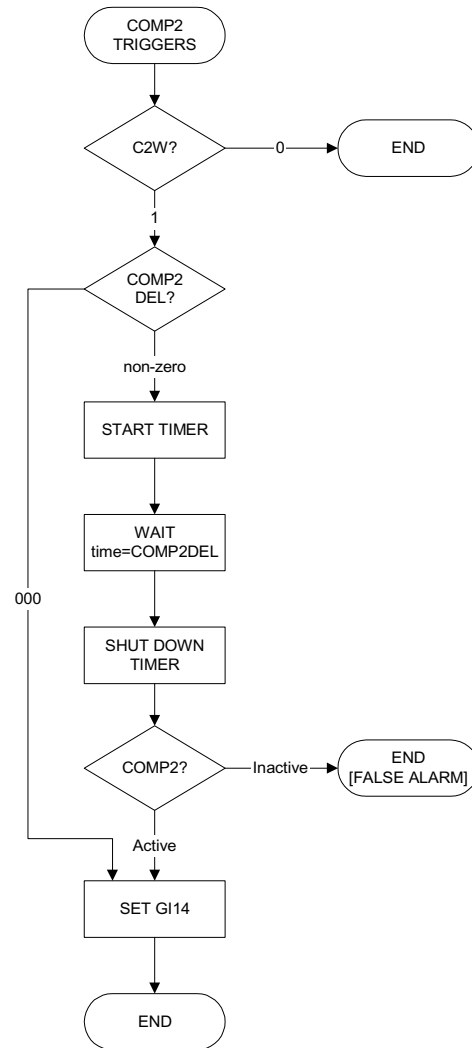

Figure 18 COMP2 Delay Flow Chart

GPIO AND INTERRUPT CONTROL

The WM9714L has eight GPIO pins that operate as defined in the AC'97 Revision 2.2 specification. Each GPIO pin can be set up as an input or as an output, and has corresponding bits in register 54h and in slot 12. The state of a GPIO output is determined by sending data through slot 12 of outgoing frames (SDATAOUT). Data can be returned from a GPIO input by reading the register bit, or examining slot 12 of incoming frames (SDATAIN). GPIO inputs can be made sticky, and can be programmed to generate an interrupt, transmitted either through the AC-Link or through a dedicated, level-mode interrupt pin (GPIO2/IRQ, pin 45).

In addition, the GPIO pins 1, 3, 4 and 5 can be used for the PCM interface by setting bit 15 of register 36h (see "PCM Codec" section). Setting this bit disables any GPIO functions selected on these pins.

REGISTER ADDRESS	BIT	LABEL	DEFAULT	DESCRIPTION
36h PCM Codec Control	15	CTRL	0	Enables PCM interface on GPIO pins 1, 3, 4 and 5. 0: Normal GPIO functions 1: PCM interface enabled
56h GPIO Pin Sharing	8:2	GE#	1 (GPIO)	Toggle GPIO pin function: 0: secondary function enabled 1: GPIO enabled

Table 55 GPIO Additional Function Control

GPIO pins 2 to 8 are multi-purpose pins that can also be used for other (non-GPIO / -PCM) purposes, e.g. as a SPDIF output. This is controlled by register 56h.

Note that GPIO6/7/8 each have an additional function independent of the GPIO / auxiliary functions discussed above. If these pins are to be used as GPIO then the independent function needs to be disabled using its own control registers, e.g. to use pin 11 as a GPIO then the RESETB function needs to be disabled (RSTDIS, register 5Ah, bit 8).

Independently of the GPIO pins, the WM9714L also has seven virtual GPIOs. These are signals from inside the WM9714L, which are treated as if they were GPIO input signals. From a software perspective, virtual GPIOs are the same as GPIO pins, but they cannot be set up as outputs, and are not tied to an actual pin. This allows for simple, uniform processing of different types of signals that may generate interrupts (e.g. battery warnings, jack insertion, high-temperature warning, or GPIO signals).

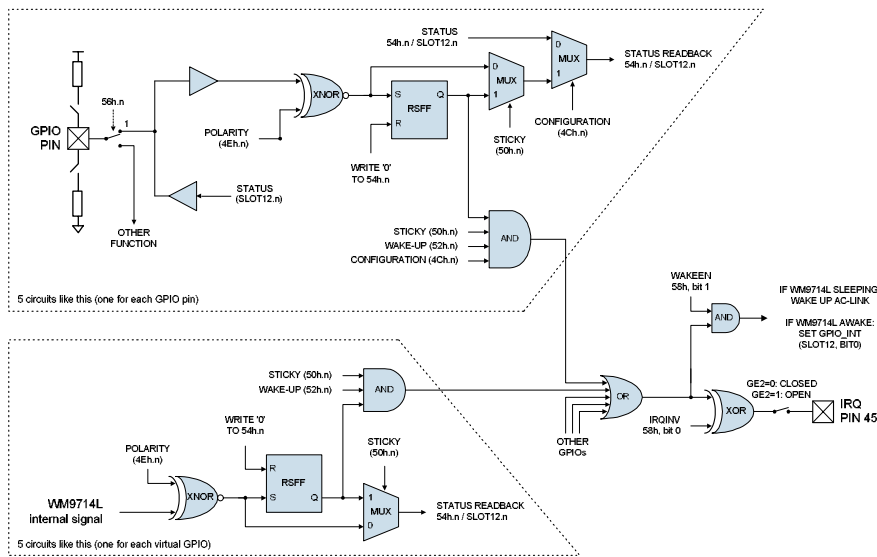

Figure 19 GPIO Logic

GPIO BIT	SLOT 12 BIT	TYPE	PIN NO.	DESCRIPTION
1	5	GPIO Pin	44	GPIO1
2	6	GPIO Pin	45	GPIO2 / IRQ enabled only when pin not used as IRQ
3	7	GPIO Pin	46	GPIO3
4	8	GPIO Pin	47	GPIO4 / ADA / MASK enabled only when pin not used as ADA
5	9	GPIO Pin	48	GPIO5 / SPDIF_OUT enabled only when pin not used as SPDIF_OUT
6	10	GPIO Pin	3	GPIO6 / ADA / MASK Enabled only when pin not used as ADA
7	11	GPIO Pin	11	GPIO7
8	12	GPIO Pin	12	GPIO8 / SPDIF_OUT enabled only when pin not used as SPDIF_OUT
9	13	Virtual GPIO	- [MICDET]	Internal microphone bias current detect, generates an interrupt above a threshold (see MICBIAS Current Detect)
10	14	Virtual GPIO	- [MICSHT]	Internal shorted microphone detect, generates an interrupt above a threshold (see MICBIAS Current Detect)
11	15	Virtual GPIO	- [Thermal Cutout]	Internal thermal cutout signal, indicates when internal temperature reaches approximately 150°C (see "Thermal Sensor")
12	16	virtual GPIO	- [ADA]	Internal ADA (ADC Data Available) Signal enabled only when AUX ADC is active
13	17	Virtual GPIO	-	Not used
14	18	Virtual GPIO	- [COMP2]	Internal COMP2 output (Low Battery Alarm) enabled only when COMP2 is on
15	19	Virtual GPIO	- [COMP1]	Internal COMP1 output (Dead Battery Alarm) enabled only when COMP1 is on

Table 56 GPIO Bits and Pins

Note: GPIO7 (Pin 11) has an independent RESETB function. This must be disabled using RSTDIS (Register 5Ah, bit 8) before using Pin 11 as a GPIO.

The properties of the GPIOs are controlled through registers 4Ch to 52h, as shown below.

REGISTER ADDRESS	BIT	LABEL	DEFAULT	DESCRIPTION	
4Ch	n	GCn	1	GPIO Pin Configuration 0: Output 1: Input GC9-15 are always '1'	
4Eh	n	GPn	1	GPIO Pin Polarity / Type	
				Input (GCn=1)	Output (GCn=0)
				0: Active Low 1: Active High [GIn = pin level XNOR GPn]	0: Active High 1: Active low
50h	n	GSn	0	GPIO Pin Sticky 1: Sticky 0: Not Sticky	
52h	n	GWn	0	GPIO Pin Wake-up 1: Wake Up (generate interrupts from this pin) 0: No wake-up (no interrupts generated)	
54h	n	GIn	N/A	GPIO Pin Status Read: Returns status of each GPIO pin Write: Writing '0' clears sticky bit	

Table 57 GPIO Control

The following procedure is recommended for handling interrupts:

When the controller receives an interrupt, check register 54h. For each GPIO bit in descending order of priority, check if the bit is '1'. If yes, execute corresponding interrupt routine, then write '0' to corresponding bit in 54h. If no, continue to next lower priority GPIO. After all GPIOs have been checked, check if interrupt still present or no. If yes, repeat procedure. If no, then jump back to process that ran before the interrupt.

If the system CPU cannot execute such an interrupt routine, it may be preferable to switch an internal signal directly onto the GPIO pins. However, in this case the interrupt signals cannot be made sticky, and more GPIO pins are tied up both on the WM9714L and on the CPU.

REGISTER ADDRESS	BIT	LABEL	DEFAULT	DESCRIPTION
56h GPIO pins function select	2	GE2	1	GPIO2 / IRQ output select 0: Pin 45 disconnected from GPIO logic set 4Ch, bit 2 to '0' to output IRQ signal 1: Pin 45 connected to GPIO logic (IRQ disabled)
	3	GE3	1	GPIO3 output select 0: Pin 46 disconnected from GPIO logic 1: Pin 46 connected to GPIO logic
	4	GE4	1	GPIO4 / ADA / MASK output select 0: Pin 47 disconnected from GPIO logic set 4Ch, bit 4 to '0' to output ADA signal set 4Ch, bit 4 to '1' to input MASK signal 1: Pin 47 connected to GPIO logic
	5	GE5	1	GPIO5 / SPDIF output select 0: Pin 48 = SPDIF (disconnected from GPIO logic) set 4Ch, bit 5 to '0' to output SPDIF signal 1: Pin 48 connected to GPIO logic (SPDIF disabled)
	6	GE6	1	GPIO6 / ADA / MASK output select 0: Pin 3 disconnected from GPIO logic set 4Ch, bit 6 to '0' to output ADA signal set 4Ch, bit 6 to '1' to input MASK signal 1: Pin 3 connected to GPIO logic
	7	GE7	1	GPIO7 0: Pin 11 disconnected from GPIO logic 1: Pin 11 connected to GPIO logic
	8	GE8	1	GPIO8 / SPDIF output select 0: Pin 12 = SPDIF (disconnected from GPIO logic) set 4Ch, bit 8 to '0' to output SPDIF signal 1: Pin 12 connected to GPIO logic (SPDIF disabled)

Table 58 Using GPIO Pins for Non-GPIO Functions

POWER MANAGEMENT

INTRODUCTION

The WM9714L includes the standard power down control register defined by the AC'97 specification (register 26h). Additionally, it also allows more specific control over the individual blocks of the device through register Powerdown registers 3Ch and 3Eh. Each particular circuit block is active when both the relevant bit in register 26h AND the relevant bit in the Powerdown registers 3Ch and 3Eh are set to '0'.

Note that the default power-up condition is all OFF.

AC97 CONTROL REGISTER

REGISTER ADDRESS	BIT	LABEL	DEFAULT	DESCRIPTION
26h Powerdown/ Status register	14	PR6	1 (OFF)	Disables all output PGAS
	13	PR5	1 (OFF)	Disables internal clock
	12	PR4	1 (OFF)	Disables AC-link interface (external clock off)
	11	PR3	1 (OFF)	Disables VREF, input PGAs, DACs, ADCs, mixers and outputs
	10	PR2	1 (OFF)	Disables input PGAs and mixers
	9	PR1	1 (OFF)	Disables stereo DAC
	8	PR0	1 (OFF)	Disables stereo ADCs and record mux PGA
	3	REF	0	Read-only bit, indicates VREF is ready (inverse of PR2)
	2	ANL	0	Read-only bit, indicates analogue mixers are ready (inverse of PR3)
	1	DAC	0	Read-only bit, indicates stereo DAC is ready (inverse of PR1)
0	ADC	0	Read-only bit, indicates stereo ADC is ready (inverse of PR0)	

Table 59 Powerdown and Status Register (Conforms to AC'97 Rev 2.2)

EXTENDED POWERDOWN REGISTERS

REGISTER ADDRESS	BIT	LABEL	DEFAULT	DESCRIPTION
3Ch Powerdown (1)	15	PADCPD	1 (OFF)	Disables aux ADC
	14	VMID1M	1 (OFF)	Disables 1Meg Vmid resistor string
	13	TSHUT	1 (OFF)	Disables thermal shutdown
	12	VXDAC	1 (OFF)	Disables VXDAC
	11	AUXDAC	1 (OFF)	Disables AUXDAC
	10	MBIAS	1 (OFF)	Disables master bias reference generator
	9	PLL	1 (OFF)	Disables PLL
	7	DACL	1 (OFF)	Disables left DAC (see Note 1)
	6	DACR	1 (OFF)	Disables right DAC (see Note 1)
	5	ADCL	1 (OFF)	Disables left ADC
	4	ADCR	1 (OFF)	Disables right ADC
	3	HPLX	1 (OFF)	Disables left headphone mixer
	2	HPRX	1 (OFF)	Disables right headphone mixer
1	SPKX	1 (OFF)	Disables speaker mixer	
0	MX	1 (OFF)	Disables mono mixer	

Note: When analogue inputs or outputs are disabled, they are internally connected to VREF through a large resistor ($VREF=AVDD/2$ except when VREF and VMID1M are both OFF). This maintains the potential at that node and helps to eliminate pops when the pins are re-enabled.

Table 60 Extended Power Down Register (1) (Additional to AC'97 Rev 2.2)

Note:

1. When disabling a PGA, always ensure that it is muted first.

REGISTER ADDRESS	BIT	LABEL	DEFAULT	DESCRIPTION
3Eh Powerdown (2)	15	MCD	1 (OFF)	Disables microphone current detect
	14	MICBIAS	1 (OFF)	Disables microphone bias
	13	MONO	1 (OFF)	Disables MONO output PGA (see Note 1)
	12	OUT4	1 (OFF)	Disables OUT4 output PGA (" ")
	11	OUT3	1 (OFF)	Disables OUT3 output PGA (" ")
	10	HPL	1 (OFF)	Disables HPL output PGA (" ")
	9	HPR	1 (OFF)	Disables HPR output PGA (" ")
	8	SPKL	1 (OFF)	Disables SPKL output PGA (" ")
	7	SPKR	1 (OFF)	Disables SPKR output PGA (" ")
	6	LL	1 (OFF)	Disables LINEL PGA (" ")
	5	LR	1 (OFF)	Disables LINER PGA (" ")
	4	MOIN	1 (OFF)	Disables MONOIN PGA (" ")
	3	MA	1 (OFF)	Disables mic PGA MA (" ")
	2	MB	1 (OFF)	Disables mic PGA MB (" ")
	1	MPA	1 (OFF)	Disables mic pre-amp MPA
	0	MPB	1 (OFF)	Disables mic pre-amp MPB

Note: When analogue inputs or outputs are disabled, they are internally connected to VREF through a large resistor (VREF=AVDD/2 except when VREF and VMID1M are both OFF). This maintains the potential at that node and helps to eliminate pops when the pins are re-enabled.

Table 61 Extended Power Down Register (2) (Additional to AC'97 Rev 2.2)

Note:

1. When disabling a PGA, always ensure that it is muted first.

ADDITIONAL POWER MANAGEMENT

Mixer output inverters: see "Mixer output Inverters" section. Inverters are OFF by default.

SLEEP MODE

Whenever the PR4 bit (reg. 26h) is set, the AC-Link interface is disabled, and the WM9714L is in sleep mode. There is in fact a very large number of different sleep modes, depending on the other control bits. For example, the low-power standby mode described below is a sleep mode. It is desirable to use sleep modes whenever possible, as this will save power. The following functions do not require a clock and can therefore operate in sleep mode:

- Analogue-to-analogue audio (DACs and ADCs unused), e.g. phone call mode
- GPIO and interrupts
- Battery alarm / analogue comparators

The WM9714L can awake from sleep mode as a result of

- A warm reset on the AC-Link (according to the AC'97 specification)
- A signal on a GPIO pin (if the pin is configured as an input, with wake-up enabled – see "GPIO and Interrupt Control" section)
- A virtual GPIO event such as battery alarm, etc. (see "GPIO and Interrupt Control" section)

LOW POWER STANDBY MODE

If all the bits in registers 26h, 3Ch and 3Eh are set except VMID1M (register 3Ch, bit 14), then the WM9714L is in low-power standby mode and consumes very little current. A $1M\Omega$ resistor string remains connected across AVDD to generate VREF. This is necessary if the on-chip analogue comparators are used (see "Battery Alarm and Battery Measurement" section), and helps shorten the delay between wake-up and playback readiness. If VREF is not required, the $1M\Omega$ resistor string can be disabled by setting the VMID1M bit, reducing current consumption further.

SAVING POWER AT LOW SUPPLY VOLTAGES

The analogue supplies to the WM9714L can run from 1.8V to 3.6V. By default, all analogue circuitry on the IC is optimized to run at 3.3V. This set-up is also good for all other supply voltages down to 1.8V. However, at lower voltages, it is possible to save power by reducing the internal bias currents used in the analogue circuitry. This is controlled as shown below.

REGISTER ADDRESS	BIT	LABEL	DEFAULT	DESCRIPTION
5Ch	6:5	VBIAS	00	Analogue Bias optimization 11 : Lowest bias current, optimized for 1.8V 10 : Low bias current, optimized for 2.5V 01, 00 : Default bias current, optimized for 3.3V

Table 62 Analogue Bias Selection

POWER ON RESET (POR)

The WM9714L has an internal power on reset (PORB) which ensures that a reset is applied to all registers until a supply threshold has been exceeded. The POR circuitry monitors the voltage for both AVDD and DCVDD and will release the internal reset signal once these supplies are both nominally greater than 1.36V. The internal reset signal is an AND of the PORB and RESETB input signal.

It is recommended that for operation of the WM9714L, all device power rails should be stable before configuring the device for operation.

AC97 INTERFACE TIMING

Test Characteristics:

DBVDD = 3.3V, DCVDD = 3.3V, DGND1 = DGND2 = 0V, $T_A = -25^\circ\text{C}$ to $+85^\circ\text{C}$, unless otherwise stated.

CLOCK SPECIFICATIONS

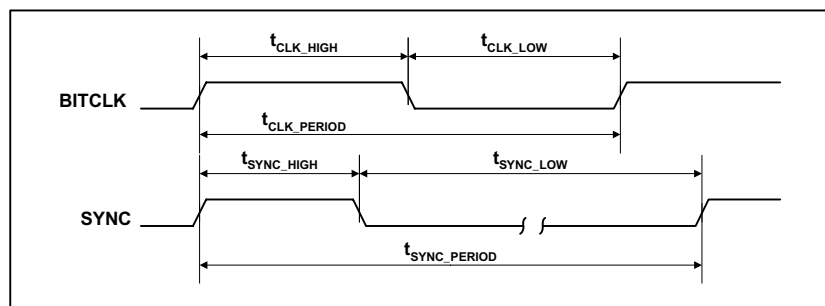

Figure 20 Clock Specifications (50pF External Load)

PARAMETER	SYMBOL	MIN	TYP	MAX	UNIT
BITCLK frequency			12.288		MHz
BITCLK period	t_{CLK_PERIOD}		81.4		ns
BITCLK output jitter				750	ps
BITCLK high pulse width (Note 1)	t_{CLK_HIGH}	36	40.7	45	ns
BITCLK low pulse width (Note 1)	t_{CLK_LOW}	36	40.7	45	ns
SYNC frequency			48		kHz
SYNC period	t_{SYNC_PERIOD}		20.8		μ s
SYNC high pulse width	t_{SYNC_HIGH}		1.3		μ s
SYNC low pulse width	t_{SYNC_LOW}		19.5		μ s

Note:

1. Worst case duty cycle restricted to 45/55

DATA SETUP AND HOLD

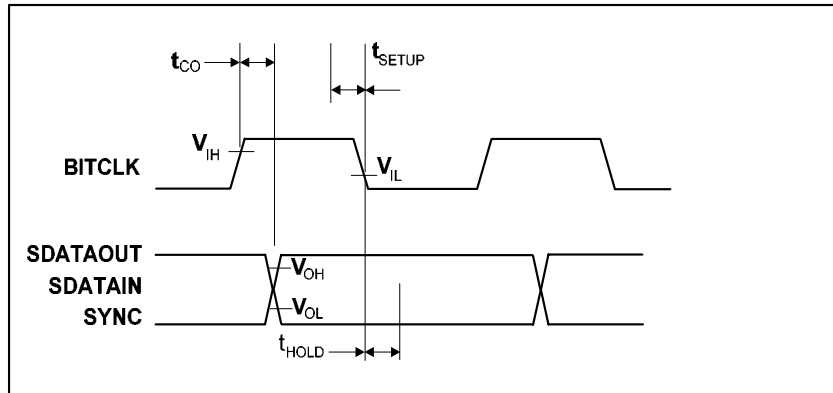

Figure 21 Data Setup and Hold (50pF External Load)

Note:

Setup and hold times for SDATAIN are with respect to the AC'97 controller, not the WM9714L.

PARAMETER	SYMBOL	MIN	TYP	MAX	UNIT
Setup to falling edge of BITCLK	t_{SETUP}	10			ns
Hold from falling edge of BITCLK	t_{HOLD}	10			Ns
Output valid delay from rising edge of BITCLK	t_{CO}			15	ns

SIGNAL RISE AND FALL TIMES

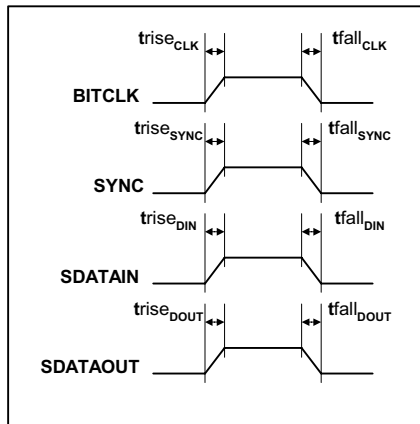

Figure 22 Signal Rise and Fall Times (50pF External Load)

PARAMETER	SYMBOL	MIN	TYP	MAX	UNIT
BITCLK rise time	$trise_{CLK}$	2		6	ns
BITCLK fall time	$tfall_{CLK}$	2		6	ns
SYNC rise time	$trise_{SYNC}$	2		6	ns
SYNC fall time	$tfall_{SYNC}$	2		6	ns
SDATAIN rise time	$trise_{DIN}$	2		6	ns
SDATAIN fall time	$tfall_{DIN}$	2		6	ns
SDATAOUT rise time	$trise_{DOUT}$	2		6	ns
SDATAOUT fall time	$tfall_{DOUT}$	2		6	ns

AC-LINK POWERDOWN

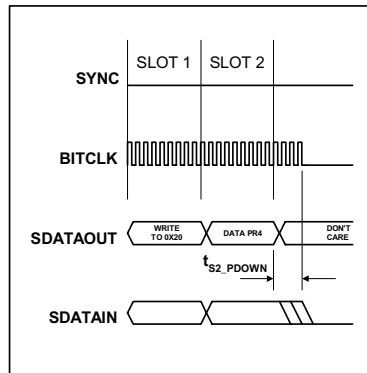

Figure 23 AC-Link Powerdown Timing

AC-Link powerdown occurs when PR4 (register 26h, bit 12) is set (see “Power Management” section).

PARAMETER	SYMBOL	MIN	TYP	MAX	UNIT
End of Slot 2 to BITCLK and SDATAIN low	t_{S2_PDOWN}			1.0	μs

COLD RESET (ASYNCHRONOUS, RESETS REGISTER SETTINGS)

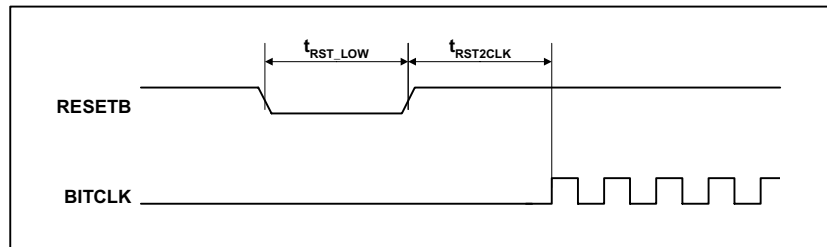
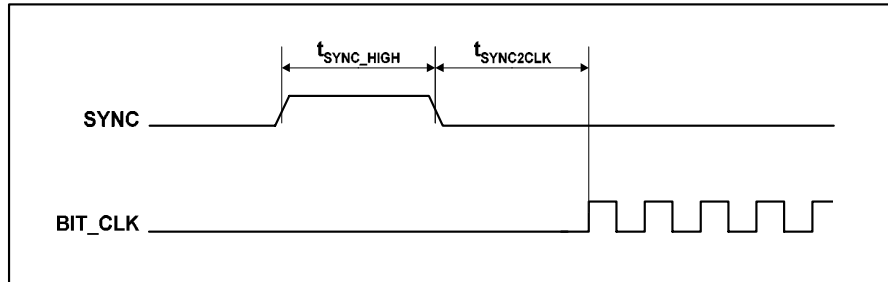

Figure 24 Cold Reset Timing

Note:

For correct operation SDATAOUT and SYNC must be held LOW for entire RESETB active low period otherwise the device may enter test mode. See AC'97 specification or Wolfson applications note WAN104 for more details.

PARAMETER	SYMBOL	MIN	TYP	MAX	UNIT
RESETB active low pulse width	t_{RST_LOW}	1.0			μs
RESETB inactive to BITCLK startup delay	$t_{RST2CLK}$	162.8			ns

WARM RESET (ASYNCHRONOUS, PRESERVES REGISTER SETTINGS)**Figure 25 Warm Reset Timing**

PARAMETER	SYMBOL	MIN	TYP	MAX	UNIT
SYNC active high pulse width	$t_{\text{SYNC_HIGH}}$		1.3		μs
SYNC inactive to BITCLK startup delay	t_{RST2CLK}	162.4			ns

REGISTER MAP

Reg	Name	15	14	13	12	11	10	9	8	7	6	5	4	3	2	1	0	Default		
00h	Reset	0	SE4	SE3	SE2	SE1	SE0	ID9	ID8	ID7	ID6	ID5	ID4	ID3	ID2	ID1	ID0	6174h		
02h	Speaker Volume	MUL	ZCL	SPKLVOL						MUR	ZCR	SPKRVOL						8080h		
04h	Headphone Volume	MUL	ZCL	HPLVOL						MUR	ZCR	HPRVOL						8080h		
06h	OUT3/4 Volume	MU4	ZC4	OUT4VOL						MU3	ZC3	OUT3VOL						8080h		
08h	MONO Vol & MONOIN PGA Vol / Routing	M2H	M2S	0	MONOINVOL						MU	ZC	MONOVOL						C880h	
0Ah	LINEIN PGA Volume / Routing	L2H	L2S	L2M	LINELVOL						0	0	0	LINERVOL						E808h
0Ch	DAC PGA Volume / Routing	D2H	D2S	D2M	DACLVOL						0	0	0	DACRVOL						E808h
0Eh	MIC PGA Volume	0	0	0	MICAVAL						0	0	0	MICBVAL						0808h
10h	MIC Routing	0	0	0	0	0	0	0	0	MA2M	MB2M	MIC2MBS	MIC2H	MIC2HVOL				00DAh		
12h	Record PGA Volume	RMU	GRL	(Extended) RECVOLL						ZC	GRR	(Extended) RECVOLR						8000h		
14h	Record Routing / Mux Select	R2H	R2HVOL			R2M			R2MBS	0	REC	RECSL			RECSR			D600h		
16h	PCBEEP Volume / Routing	B2H	B2HVOL		B2S	B2SVOL			B2M	B2MVOL			0	0	0	0	AAA0h			
18h	VxDAC Volume / Routing	V2H	V2HVOL		V2S	V2SVOL			V2M	V2MVOL			0	0	0	0	AAA0h			
1Ah	AUXDAC Volume / Routing	A2H	A2HVOL		A2S	A2SVOL			A2M	A2MVOL			0	0	0	0	AAA0h			
1Ch	Output PGA Mux Select	MONO		SPKL			SPKR			HPL		HPR		OUT3		OUT4		0000h		
1Eh	DAC 3D Control & INV Mux Select	INVA			INVB			0	0	0	0	3DLC	3DUC	3DDEPTH				0000h		
20h	DAC Tone Control	BB	0	0	BC	BASS				0	DAT	0	TC	TRBL				0F0Fh		
22h	MIC Input Select & Bias / Detect Ctrl	MICMPSEL		MPASEL		MPABST		MPBBST		MBOP2EN	MBOP1EN	MBVOL	MCDTHR		MCDSCTHR			0040h		
24h	Output Volume Mapping (Jack Insert)	0	0	0	0	0	0	0	0	0	0	0	JIE	DCDRVSEL	EARSPKSEL			0000h		
26h	Powerdown Ctr/Stat	0	PR6	PR5	PR4	PR3	PR2	PR1	PRO	0	0	0	0	REF	ANL	DAC	ADC	7F00h		
28h	Extended Audio ID	ID1	ID0	0	0	REV1	REV0	AMAP	LDAC	SDAC	CDAC	0	0	VRM	SPDIF	DRA	VRA	0405h		
2Ah	Ext'd Audio Stat/Ctrl	0	0	0	0	0	SPCV	0	0	0	0	0	SPSA	0	SEN	0	VRA	0410h		
2Ch	Audio DACs Sample Rate	DACSR (Audio DACs Sample Rate)																BB80h		
2Eh	AUXDAC Sample Rate	AUXDACSR (Auxiliary DAC Sample Rate)																BB80h		
22h	Audio ADCs Sample Rate	ADCSR (Audio ADCs Sample Rate)																BB80h		
36h	PCM codec control	CTRL	MODE	SWAP	DIV				VDACSR	CP	FSP	SEL			WL	FMT			4523h	
3Ah	SPDIF control	V	DRS	SPSR		L	CC (Category Code)						PRE	COPY	AUDIB	PRO	0000h			
3Ch	Powerdown (1)	PADCPD	VMD1M	TSHUT	VXDAC	AUXDAC	MBIAS	PLL	1	DACL	DACR	ADCL	ADCR	HPLX	HPRX	SPXK	MX	FEFFh		
3Eh	Powerdown (2)	MCD	MICBIAS	MONO	OUT4	OUT3	HPL	HPR	SPKL	SPKR	LL	LR	MOIN	MA	MB	MPA	MPB	FFFFh		
40h	General Purpose	0	0	3DE	0	0	0	0	0	LB	0	0	0	0	0	0	0	0000h		
42h	Fast Power-Up Control	0	0	0	0	0	0	0	0	0	MONO	SPKL	SPKR	HPL	HPR	OUT3	OUT4	0000h		
44h	MCLK / PLL Control	0	SEXT[6:4]				SEXT[3:0]				CLKSRC	0	PENDIV		CLKX2	CLKMUX	0080h			
46h	MCLK / PLL Control	N[3:0]			LF	SDM	DIVSEL	DIVCTL	0	PGADDR			PGDATA					0000h		
4Ch	GPIO Pin Configuration	1	1	1	1	1	1	1	GC8	GC7	GC6	GC5	GC4	GC3	GC2	GC1	0	FFFEh		
4Eh	GPIO Pin Polarity / Type	C1P	C2P	PP	AP	TP	SP	MP	GP8	GP7	GP6	GP5	GP4	GP3	GP2	GP1	1	FFFFh		
50h	GPIO Pin Sticky	C1S	C2S	PS	AS	TS	SS	MS	GS8	GS7	GS6	GS5	GS4	GS3	GS2	GS1	0	0000h		
52h	GPIO Pin Wake-Up	C1W	C2W	PW	AW	TW	SW	MW	GW8	GW7	GW6	GW5	GW4	GW3	GW2	GW1	0	0000h		
54h	GPIO Pin Status	C1I	C2I	PI	AI	TI	SI	MI	GI8	GI7	GI6	GI5	GI4	GI3	GI2	GI1	0	GPIO pins		
56h	GPIO Pin Sharing	1	1	1	1	1	1	1	GE8	GE7	GE6	GE5	GE4	GE3	GE2	1	0	FFFEh		
58h	GPIO Pull UP/DOWN Ctr	PU8	PU7	PU6	PU5	PU4	PU3	PU2	PU1	PD8	PD7	PD6	PD5	PD4	PD3	PD2	PD1	4000h		
5Ah	Additional Functions (1)	COMP2DEL		0	0	0	0	RSTDIS	JSEL		HPMODE		Die Revision		WAKEEN	IRQINV	0000h			
5Ch	Additional Functions (2)	AMUTE	C1REF	C1SRC		C2REF	C2SRC		0	AMEN	VBIAS		ADCO	HPF	0	ASS			0000h	
60h	ALC Control	ALCL (target level)				HLD (hold time)				DCY (decay time)				ATK (attack time)				B032h		
62h	ALC / Noise Gate Control	ALCSEL		MAXGAIN			ZCTIMEOUT		ALCZC	NGAT	0	NGG	NGTH (threshold)					3E00h		
64h	AUXDAC input control	XSLE	AUXDACSLT				AUXDAC VAL												0000h	
68h	Test Register (1)	EVAL	CASLPE	CMPTST	ADCTST	DMODE			DWAMODE	THERMESHUT	VMDBP	XCLKENB	DITHENB	MUTEENB	DCCAP	DPI	0060h			
6Ah	Test Register (2)	BISTEN	3DSTEN	DACTSTEN	PENADCTST				INTLPBCK	3DCLK	3DBP	BMONCNT	0	ALCTST	RMPDNENB	RAMINIT	RAMTST	0000h		
6Ch	Test Register (3)	0	0	0	IBSTMP		IBSTGBL		IBSTPADC	IADC			HIOP	HIMIX	HIPGA	HIDAC	HIADCP	0000h		
6Eh	Test Register (4)	TSTLF	TSTDIG	TSTLK	TSTRST	0	0	0	0	0	CLKDETENB	VDACTSTEN	VGPIORST	VGPIOS	WP_BCLK	WP_MCLK	0000h			
74h	Digitiser Reg 1	0	0	0	0	0	0	POLL	CTC	ADCSEL							COD		0000h	
76h	Digitiser Reg 2	0	0	0	0	0	0	CR	DEL				SLEN	SLT			0006h			
78h	Digitiser Reg 3	PRP		RPR	45W	PDEN	PDPOL	WAIT	PIL	MSK			RPU				0001h			
7Ah	Digitiser Read Back	PNDN	ADCSRC				ADCD (TOUCHPANEL ADC Y DATA)												0000h	
7Ch	Vendor ID1	ASCII character "W"								ASCII character "M"								574Dh		
7Eh	Vendor ID2	ASCII character "L"																0Dh	4C13h	

Table 63 WM9714L Register Map

REGISTER BITS BY ADDRESS

REGISTER ADDRESS	BIT	LABEL	DEFAULT	DESCRIPTION	REFER TO
00h	14:10	SE [4:0]	11000	Indicates a codec from Wolfson Microelectronics	Intel's AC'97 Component Specification, Revision 2.2, page 50
	9:6	ID9:6	0101	Indicates 18 bits resolution for ADCs and DACs	
	5	ID5	1	Indicates that the WM9714L supports bass boost	
	4	ID4	1	Indicates that the WM9714L has a headphone output	
	3	ID3	0	Indicates that the WM9714L does not support simulated stereo	
	2	ID2	1	Indicates that the WM9714L supports bass and treble control	
	1	ID1	0	Indicates that the WM9714L does not support modem functions	
0	ID0	0	Indicates that the WM9714L does not have a dedicated microphone ADC		

Register 00h is a read-only register. Writing any value to this register resets all registers to their default, but does not change the contents of reg. 00h. Reading the register reveals information about the codec to the driver, as required by the AC'97 Specification, Revision 2.2

REGISTER ADDRESS	BIT	LABEL	DEFAULT	DESCRIPTION	REFER TO
02h	15	MUL	1 (mute)	Mutes SPKL	Analogue Audio Outputs
	14	ZCL	0 (OFF)	Enables zero-cross detector on SPKL	
	13:8	SPKLVOL	000000 (0dB)	SPKL volume	
	7	MUR	1 (mute)	Mutes SPKR	
	7	ZCR	0 (OFF)	Enables zero-cross detector on SPKR	
5:0	SPKRVOL	000000 (0dB)	SPKR volume		

Register 02h controls the output pins SPKL and SPKR.

REGISTER ADDRESS	BIT	LABEL	DEFAULT	DESCRIPTION	REFER TO
04h	15	MUL	1 (mute)	Mutes HPL	Analogue Audio Outputs
	14	ZCL	0 (OFF)	Enables zero-cross detector on HPL	
	13:8	HPL VOL	000000 (0dB)	HPL volume	
	7	MUR	1 (mute)	Mutes HPR	
	6	ZCR	0 (OFF)	Enables zero-cross detector on HPR	
5:0	HPR VOL	000000 (0dB)	HPR volume		

Register 04h controls the headphone output pins, HPL and HPR.

REGISTER ADDRESS	BIT	LABEL	DEFAULT	DESCRIPTION	REFER TO
06h	15	MU4	1 (mute)	Mutes OUT4	Analogue Audio Outputs
	14	ZC4	0 (OFF)	Enables zero-cross detector	
	13:8	OUT4VOL	000000 (0dB)	OUT4 volume	
	7	MU3	1 (mute)	Mutes OUT3	
	6	ZC3	0 (OFF)	Enables zero-cross detector	
5:0	OUT3VOL	000000 (0dB)	OUT3 volume		

Register 06h controls the analogue output pins OUT3 and OUT4.

REGISTER ADDRESS	BIT	LABEL	DEFAULT	DESCRIPTION	REFER TO
08h	15	M2H	1 (mute)	Mutes MONOIN to headphone mixer paths	Analogue Inputs; Analogue Audio Outputs
	14	M2S	1 (mute)	Mutes MONOIN to speaker mixer path	
	12:8	MONOINVOL	01000 (0dB)	Controls MONOIN input gain to all mixers (but not to ADC)	
	7	MU	1 (mute)	Mutes MONO.	
	6	ZC	0 (OFF)	Enables zero-cross detector	
	5:0	MONOVOL	000000 (0dB)	MONO volume	

Register 08h controls the analogue output pin MONO and the analogue input pin MONOIN.

REGISTER ADDRESS	BIT	LABEL	DEFAULT	DESCRIPTION	REFER TO
0Ah	15	L2H	1 (mute)	Mutes LINE to headphone mixer paths	Analogue Inputs, Line Input
	14	L2S	1 (mute)	Mutes LINE to speaker mixer path	
	13	L2M	1 (mute)	Mutes LINE to mono mixer path	
	12:8	LINELVOL	01000 (0dB)	Controls LINEL input gain to all mixers (but not to ADC)	
	4:0	LINERVOL	01000 (0dB)	Controls LINER input gain to all mixers (but not to ADC)	

Register 0Ah controls the analogue input pins LINEL and LINER.

REGISTER ADDRESS	BIT	LABEL	DEFAULT	DESCRIPTION	REFER TO
0Ch	15	D2H	1 (mute)	Mutes DAC to headphone mixer path	Audio DACs
	14	D2S	1 (mute)	Mutes DAC to speaker mixer path	
	13	D2M	1 (mute)	Mutes DAC to mono mixer path	
	12:8	DACLVOL	01000 (0dB)	Controls left DAC input gain to all mixers	
	4:0	DACRVOL	01000 (0dB)	Controls right DAC input gain to all mixers	

Register 0Ch controls the audio DACs (but not AUXDAC).

REGISTER ADDRESS	BIT	LABEL	DEFAULT	DESCRIPTION	REFER TO
0Eh	12:8	MICAVOL	01000 (0dB)	Controls MICA PGA volume	Analogue Inputs, Microphone Input
	4:0	MICBVOL	01000 (0dB)	Controls MICB PGA volume	

Register 0Eh controls the microphone PGA volume (MICA and MICB).

REGISTER ADDRESS	BIT	LABEL	DEFAULT	DESCRIPTION	REFER TO
10h	7	MA2M	1 (mute)	Mutes MICA to mono mixer path	Analogue Inputs, Microphone Input
	6	MB2M	1 (mute)	Mutes MICB to mono mixer path	
	5	MIC2MBST	0 (OFF)	Enables 20dB gain boost at mono mixer for MICA and MICB	
	4:3	MIC2H	11 (mute)	Controls microphone to headphone mixer paths. 00=stereo, 01=MICA only, 10=MICB only, 11=mute MICA and MICB	
	2:0	MIC2HVOL	010 (0dB)	Controls gain of microphone to headphone mixer path	

Register 10h controls the microphone routing (MICA and MICB).

REGISTER ADDRESS	BIT	LABEL	DEFAULT	DESCRIPTION	REFER TO
12h	15	RMU	1 (mute)	Mutes audio ADC input	Audio ADC, Record Gain
	14	GRL	0 (standard)	Selects gain range for PGA of left ADC. 0=0...+22.5dB in 1.5dB steps, 1=-17.25...+30dB in 0.75dB steps	
	13:8	RECVOLL	000000 (0dB)	Controls left ADC recording volume	
	7	ZC	0 (OFF)	Enables zero-cross detector	
	6	GRR	0 (standard)	Selects gain range for PGA of left ADC. 0=0...+22.5dB in 1.5dB steps, 1=-17.25...+30dB in 0.75dB steps	
	5:0	RECVOLR	000000 (0dB)	Controls right ADC recording volume	

Register 12h controls the record volume.

REGISTER ADDRESS	BIT	LABEL	DEFAULT	DESCRIPTION	REFER TO
14h	15:14	R2H	11 (mute)	Controls record mux to headphone mixer paths. 00=stereo, 01=left ADC only, 10=right ADC only, 11=mute left and right	Audio ADC, Record Selector
	13:11	R2HVOL	010 (0dB)	Controls gain of record mux l/r to headphone mixer paths	
	10:9	R2M	11 (mute)	Controls record mux to mono mixer path. 00=stereo, 01=left rec mux only, 10=right rec mux only, 11=mute left and right	
	8	R2MBST	0 (OFF)	Enables 20dB gain boost for record mux to mono mixer path	
	6	RECBST	0 (OFF)	Enables 20dB gain boost for ADC record path	
	5:3	RECSL	000 (mic)	Selects left record mux signal source: 000=MICA, 001=MICB, 010=LINEL, 011=MONOIN, 100=HPMIXL, 101=SPKMIC, 110=MONOMIX, 111=Z _h	
	2:0	RECSR	000 (mic)	Selects right record mux signal source: 000=MICA, 001=MICB, 010=LINER, 011=MONOIN, 100=HPMIXR, 101=SPKMIC, 110=MONOMIX, 111=Z _h	

Register 14h controls the record selector and the ADC to mono mixer path.

REGISTER ADDRESS	BIT	LABEL	DEFAULT	DESCRIPTION	REFER TO
16h	15	B2H	1 (mute)	Mutes PCBEEP to headphone mixer paths	Analogue Inputs, PCBEEP Input
	14:12	B2HVOL	010 (0dB)	Controls gain of PCBEEP to headphone mixer paths	
	11	B2S	1 (mute)	Mutes PCBEEP to speaker mixer path	
	10:8	B2SVOL	010 (0dB)	Controls gain of PCBEEP to speaker mixer path	
	7	B2M	1 (mute)	Mutes PCBEEP to mono mixer path	
	6:4	B2MVOL	010 (0dB)	Controls gain of PCBEEP to mono mixer path	

Register 16h controls the analogue input pin PCBEEP.

REGISTER ADDRESS	BIT	LABEL	DEFAULT	DESCRIPTION	REFER TO
18h	15	V2H	1 (mute)	Mutes VXDAC to headphone mixer paths	Audio Mixers, Side Tone Control
	14:12	V2HVOL	010 (0dB)	Controls gain of VXDAC to headphone mixer paths	
	11	V2S	1 (mute)	Mutes VXDAC to speaker mixer path	
	10:8	V2SVOL	010 (0dB)	Controls gain of VXDAC to speaker mixer path	
	7	V2M	1 (mute)	Mutes VXDAC to mono mixer path	
	6:4	V2MVOL	010 (0dB)	Controls gain of VXDAC to mono mixer path	

Register 18h controls the output signal of the Voice DAC.

REGISTER ADDRESS	BIT	LABEL	DEFAULT	DESCRIPTION	REFER TO
1Ah	15	A2H	1 (mute)	Mutes AUXDAC to headphone mixer paths	Auxiliary DAC
	14:12	A2HVOL	010 (0dB)	Controls gain of AUXDAC to headphone mixer paths	
	11	A2S	1 (mute)	Mutes AUXDAC to speaker mixer path	
	10:8	A2SVOL	010 (0dB)	Controls gain of AUXDAC to speaker mixer path	
	7	A2M	1 (mute)	Mutes AUXDAC to mono mixer path	
	6:4	A2MVOL	010 (0dB)	Controls gain of AUXDAC to mono mixer path	

Register 1Ah controls the output signal of the auxiliary DAC.

REGISTER ADDRESS	BIT	LABEL	DEFAULT	DESCRIPTION	REFER TO
1Ch	15:14	MONO	00 (Z _H)	MONO PGA input select: 00=Vmid; 01=no i/p (Z _H if buffer disabled); 10=MONOMIX; 11=INV1	Analogue Audio Outputs
	13:11	SPKL	000 (Z _H)	SPKL PGA input select: 000=Vmid; 001=no i/p (Z _H if buffer disabled); 010=HPMIXL; 011=SPKMIX; 100=INV1; 101-111=unused	
	10:8	SPKR	000 (Z _H)	SPKR PGA input select: 000=Vmid; 001=no i/p (Z _H if buffer disabled); 010=HPMIXR; 011=SPKMIX; 100=INV2; 101-111=unused	
	7:6	HPL	00 (Z _H)	HPL PGA input select: 00=Vmid; 01=no i/p (Z _H if buffer disabled); 10=HPMIXL; 11=unused	
	5:4	HPR	00 (Z _H)	HPR PGA input select: 00=Vmid; 01=no i/p (Z _H if buffer disabled); 10=HPMIXR; 11=unused	
	3:2	OUT3	00 (Z _H)	OUT3 PGA input select: 00=Vmid; 01=no i/p (Z _H if buffer disabled); 10=INV1; 11=unused	
	1:0	OUT4	00 (Z _H)	OUT4 PGA input select: 00=Vmid; 01=no i/p (Z _H if buffer disabled); 10=INV2; 11=unused	

Register 1Ch controls the inputs to the output PGAs.

REGISTER ADDRESS	BIT	LABEL	DEFAULT	DESCRIPTION	REFER TO
1Eh	15:13	INV1	000 (Z _H)	INV1 input select: 000=Z _H (OFF – no source selected); 001=MONOMIX; 010=SPKMIX; 011=HPMIXL; 100=HPMIXR; 101=HPMIXMONO; 110=unused; 111=Vmid	Audio DACs, 3D Stereo Enhancement, Analogue Audio Outputs
	12:10	INV2	000 (Z _H)	INV2 input select: 000=Z _H (OFF – no source selected); 001=MONOMIX; 010=SPKMIX; 011=HPMIXL; 100=HPMIXR; 101=HPMIXMONO; 110=unused; 111=Vmid	
	5	3DLC	0 (low)	Selects lower cut-off frequency	
	4	3DUC	0 (high)	Selects upper cut-off frequency	
	3:0	3DDEPTH	0000 (0%)	Controls depth of 3D effect	

Register 1Eh controls 3D stereo enhancement for the audio DACs and input muxes to the output inverters INV1 and INV2.

REGISTER ADDRESS	BIT	LABEL	DEFAULT	DESCRIPTION	REFER TO
20h	15	BB	0 (linear)	Selects linear bass control or adaptive bass boost	Audio DACs, Tone Control / Bass Boost
	12	BC	0 (low)	Selects bass cut-off frequency	
	11:8	BASS	1111 (OFF)	Controls bass intensity	
	6	DAT	0 (OFF)	Enables 6dB pre-DAC attenuation	
	4	TC	0 (high)	Selects treble cut-off frequency	
	3:0	TRBL	1111 (OFF)	Controls treble intensity	

Register 20h controls the bass and treble response of the left and right audio DAC (but not AUXDAC).

REGISTER ADDRESS	BIT	LABEL	DEFAULT	DESCRIPTION	REFER TO
22h	15:14	MICCOMPSEL	00 (mics)	Selects input function for MIC2A/COMP1 and MIC2B/COMP2	Analogue Inputs, Microphone Input
	13:12	MPASEL	00 (MIC1)	Selects input to MICA preamp (from MIC1, MIC2A, MIC2B)	
	11:10	MPABST	00 (12dB)	Controls MICA preamp gain boost	
	9:8	MPBBST	00 (12dB)	Controls MICB preamp gain boost	
	7	MBOP2EN	0 (Off)	Enables microphone bias output path to pin 12	
	6	MBOP1EN	1 (On)	Enables microphone bias output path to MICBIAS	
	5	MBVOL	0 (0.9xAVDD)	Selects microphone bias voltage	
	4:2	MCDTHR	000 (100uA)	Controls microphone current detect threshold	
	1:0	MCDSCTHR	00 (600uA)	Controls microphone short-circuit detect threshold	

Register 22h controls the microphone input configuration and microphone bias and detect configuration.

REGISTER ADDRESS	BIT	LABEL	DEFAULT	DESCRIPTION	REFER TO
24h	4	JIEN	0 (OFF)	Jack insert detect enable	Analogue Audio Outputs
	3:2	DCDRVSEL	00 (AC)	Output PGA source for headphone DC reference (default is AC coupled – no source selected)	
	1:0	EARSPKSEL	00	Ear speaker source select (default is no source selected)	

Register 24h controls the output volume mapping on headphone jack insertion.

REGISTER ADDRESS	BIT	LABEL	DEFAULT	DESCRIPTION	REFER TO
26h	14	PR6	1 (OFF)	Disables all output PGAS	Power Management
	13	PR5	1 (OFF)	Disables internal clock	
	12	PR4	1 (OFF)	Disables AC-link interface (external clock off)	
	11	PR3	1 (OFF)	Disables VREF, input PGAs, DACs, ADCs, mixers and outputs	
	10	PR2	1 (OFF)	Disables input PGAs and mixers	
	9	PR1	1 (OFF)	Disables stereo DAC	
	8	PR0	1 (OFF)	Disables stereo ADCs and record mux PGA	
	3	REF	0	Read-only bit, indicates VREF is ready (inverse of PR2)	
	2	ANL	0	Read-only bit, indicates analogue mixers are ready (inverse of PR3)	
	1	DAC	0	Read-only bit, indicates stereo DAC is ready (inverse of PR1)	
0	ADC	0	Read-only bit, indicates stereo ADC is ready (inverse of PR0)		

Register 26h is for power management according to the AC'97 specification. Note that the actual state of many circuit blocks depends on both register 24h AND registers 3Ch and 3Eh.

REGISTER ADDRESS	BIT	LABEL	DEFAULT	DESCRIPTION	REFER TO
28h	15:14	ID	00	Indicates that the WM9714L is configured as the primary codec in the system.	Intel's AC'97 Component Specification, Revision 2.2, page 59
	11:10	REV	01	Indicates that the WM9714L conforms to AC'97 Rev2.2	
	9	AMAP	0	Indicates that the WM9714L does not support slot mapping	
	8	LDAC	0	Indicates that the WM9714L does not have an LFE DAC	
	7	SDAC	0	Indicates that the WM9714L does not have Surround DACs	
	6	CDAC	0	Indicates that the WM9714L does not have a Centre DAC	
	3	VRM	0	Indicates that the WM9714L does not have a dedicated, variable rate microphone ADC	
	2	SPDIF	1	Indicates that the WM9714L supports SPDIF output	
	1	DRA	0	Indicates that the WM9714L does not support double rate audio	
	0	VRA	1	Indicates that the WM9714L supports variable rate audio	

Register 28h is a read-only register that indicates to the driver which advanced AC'97 features the WM9714L supports.

REGISTER ADDRESS	BIT	LABEL	DEFAULT	DESCRIPTION	REFER TO
2Ah	10	SPCV	1 (valid)	SPDIF validity bit (read-only)	Digital Audio (SPDIF) Output
	5:4	SPSA	01 (slots 6, 9)	Controls SPDIF slot assignment. 00=slots 3 and 4, 01=6/9, 10=7/8, 11=10/11	
	2	SEN	0 (OFF)	Enables SPDIF output enable	
	0	VRA	0 (OFF)	Enables variable rate audio	

Register 2Ah controls the SPDIF output and variable rate audio.

REGISTER ADDRESS	BIT	LABEL	DEFAULT	DESCRIPTION	REFER TO
2Ch	all	DACSR	BB80h	Controls stereo DAC sample rate	Variable Rate Audio / Sample Rate Conversion
2Eh	all	AUXDACSR	BB80h	Controls auxiliary DAC sample rate	
32h	all	ADCSR	BB80h	Controls audio ADC sample rate	

Note: The VRA bit in register 2Ah must be set first to obtain sample rates other than 48kHz

Registers 2Ch, 2Eh 32h and control the sample rates for the stereo DAC, auxiliary DAC and audio ADC, respectively.

REGISTER ADDRESS	BIT	LABEL	DEFAULT	DESCRIPTION	REFER TO
36h	15	CTRL	0 (GPIO reg)	Specifies how the PCM interface pins are controlled.	PCM Codec
	14:13	MODE	10 (master mode)	PCM interface mode when PCMCTRL=1	
	12	SWAP	0 (no swap)	PCM data swap	
	11:9	DIV	010 (1/4)	Voice DAC clock to PCMCLK divider	
				reserved	
	7	CP	0 (normal)	PCMCLK polarity	
	6	FSP	0	right, left and I ² S modes – PCMFS polarity DSP Mode – mode A/B select	
	5:4	SEL	00 (LandR data)	PCM ADC channel select	
	3:2	WL	10 (24 bits)	PCM Data Word Length	
1:0	FMT	10 (I ² S)	PCM Data Format Select		

Register 36h controls the PCM codec.

REGISTER ADDRESS	BIT	LABEL	DEFAULT	DESCRIPTION	REFER TO
3Ah	15	V	0	Validity bit; '0' indicates frame valid, '1' indicates frame not valid	Digital Audio (SPDIF) Output
	14	DRS	0	Indicates that the WM9714L does not support double rate SPDIF output (read-only)	
	13:12	SPSR	10	Indicates that the WM9714L only supports 48kHz sampling on the SPDIF output (read-only)	
	11	L	0	Generation level; programmed as required by user	
	10:4	CC	0000000	Category code; programmed as required by user	
	3	PRE	0	Pre-emphasis; '0' indicates no pre-emphasis, '1' indicates 50/15us pre-emphasis	
	2	COPY	0	Copyright; '0' indicates copyright is not asserted, '1' indicates copyright	
	1	AUDIB	0	Non-audio; '0' indicates data is PCM, '1' indicates non-PCM format (e.g. DD or DTS)	
0	PRO	0	Professional; '0' indicates consumer, '1' indicates professional		

Register 3Ah controls the SPDIF output.

REGISTER ADDRESS	BIT	LABEL	DEFAULT	DESCRIPTION	REFER TO
3Ch	15	PD15	1 (OFF)	AUX ADC power down	Power Management
	14	VMID1M	1 (OFF)	Disables 1Meg Vmid resistor string	
	13	TSHUT	1 (OFF)	Disables thermal shutdown	
	12	VXDAC	1 (OFF)	Disables VXDAC	
	11	AUXDAC	1 (OFF)	Disables AUXDAC	
	10	VREF	1 (OFF)	Disables reference generator	
	9	PLL	1 (OFF)	Disables PLL	
	7	DACL	1 (OFF)	Disables left DAC	
	6	DACR	1 (OFF)	Disables right DAC	
	5	ADCL	1 (OFF)	Disables left ADC	
	4	ADCR	1 (OFF)	Disables right ADC	
	3	HPLX	1 (OFF)	Disables left headphone mixer	
	2	HPRX	1 (OFF)	Disables right headphone mixer	
	1	SPKX	1 (OFF)	Disables speaker mixer	
0	MX	1 (OFF)	Disables mono mixer		

* "0" corresponds to "ON", if and only if the corresponding bit in register 26h is also 0.

Register 3Ch is for power management additional to the AC'97 specification. Note that the actual state of each circuit block depends on both register 3Ch AND register 26h.

REGISTER ADDRESS	BIT	LABEL	DEFAULT	DESCRIPTION	REFER TO
3Eh	15	MCD	1 (OFF)	Disables microphone current detect	Power Management
	14	MICBIAS	1 (OFF)	Disables microphone bias	
	13	MONO	1 (OFF)	Disables MONO output PGA	
	12	OUT4	1 (OFF)	Disables OUT4 output PGA	
	11	OUT3	1 (OFF)	Disables OUT3 output PGA	
	10	HPL	1 (OFF)	Disables HPL output PGA	
	9	HPR	1 (OFF)	Disables HPR output PGA	
	8	SPKL	1 (OFF)	Disables SPKL output PGA	
	7	SPKR	1 (OFF)	Disables SPKR output PGA	
	6	LL	1 (OFF)	Disables LINEL PGA	
	5	LR	1 (OFF)	Disables LINER PGA	
	4	MOIN	1 (OFF)	Disables MONOIN PGA	
	3	MA	1 (OFF)	Disables mic PGA MA	
	2	MB	1 (OFF)	Disables mic PGA MB	
1	MPA	1 (OFF)	Disables mic pre-amp MPA		
0	MPB	1 (OFF)	Disables mic pre-amp MPB		

* "0" corresponds to "ON", if and only if the corresponding bit in register 26h is also 0.

Register 3Eh is for power management additional to the AC'97 specification. Note that the actual state of each circuit block depends on both register 3Eh AND register 26h.

REGISTER ADDRESS	BIT	LABEL	DEFAULT	DESCRIPTION	REFER TO
40h	13	3DE	0 (OFF)	Enables 3D enhancement	Audio DACs, 3D Stereo Enhancement
	7	LB	0 (OFF)	Enables loopback (i.e. feed ADC output data directly into DAC)	Intel's AC'97 Component Specification, Revision 2.2, page 55

Register 40h is a "general purpose" register as defined by the AC'97 specification. Only two bits are implemented in the WM9714L.

REGISTER ADDRESS	BIT	LABEL	DEFAULT	DESCRIPTION	REFER TO
42h	6	MONO	0 (Off)	Enables fast power for MONO output	Analogue Audio Outputs, Power-Up
	5	SPKL	0 (Off)	Enables fast power for SPKL output	
	4	SPKR	0 (Off)	Enables fast power for SPKR output	
	3	HPL	0 (Off)	Enables fast power for HPL output	
	2	HPR	0 (Off)	Enables fast power for HPR output	
	1	OUT3	0 (Off)	Enables fast power for OUT3 output	
	0	OUT4	0 (Off)	Enables fast power for OUT4 output	

Register 42h controls power-up conditions for output PGAs.

REGISTER ADDRESS	BIT	LABEL	DEFAULT	DESCRIPTION	REFER TO
44h	14:1 2	S _{EXT} [6:4]	000 (div 1)	Defines clock division ratio for Hi-fi block: 000=f; 001=f/2; ... ; 111=f/8	Clock Generation
	11:8	S _{EXT} [3:0]	0000 (div 1)	Defines clock division ratio for PCM interface and voice DAC: 0000=f; 0001=f/1; ... ; 1111=f/16	
	7	CLKSRC	1 (ext clk)	Selects between PLL clock and External clock	
	5:3	PENDIV	000 (div 16)	Sets AUXADC clock divisor: 000=f/16; 001=f/12; 010=f/8; 011=f/6; 100=f/4; 101=f/3; 110=f/2; 111=f	
	2	CLKBX2	0 (Off)	Clock doubler for MCLKB	
	1	CLKAX2	0 (Off)	Clock doubler for MCLKA	
	0	CLKMUX	0 (MCLKA)	Selects between MCLKA and MCLKB (N.B. On power-up clock must be present on MCLKA and must be active for 2 clock cycles after switching to MCLKB)	

Register 44h controls clock division and muxing.

REGISTER ADDRESS	BIT	LABEL	DEFAULT	DESCRIPTION	REFER TO
46h	15:1 2	N[3:0]	0000	PLL integer division control (must be set between 5-12 for integer N mode)	Analogue Audio Outputs, Power-Up
	11	LF	0 = off	Allows PLL operation with low frequency input clocks (< 8.192MHz)	
	10	SDM	0	Sigma Delta Modulator enable. Allows fractional N division	
	9	DIVSEL	0 = off	Enables input clock to PLL to be divided by 2 or 4. Use if input clock is above 14.4MHz	
	8	DIVCTL	0	Controls division mode when DIVSEL is high. 0 = div by 2, 1 = div by 4.	
	6:4	PGADDR	000	Pager address bits to access programming of K[21:0] and S _{PLL} [7:0]	
	3:0	PGDATA	0000	Pager data bits	

Register 46h controls PLL clock generation.

REGISTER ADDRESS	BIT	LABEL	DEFAULT	DESCRIPTION	REFER TO
4Ch			all 1 (all inputs) except unused bits	Controls GPIO configuration as inputs or as outputs (note: virtual GPIOs can only be inputs)	GPIO and Interrupt Control
4Eh			all 1	Controls GPIO polarity (actual polarity depends on register 4Ch AND register 4Eh)	
50h			all 0 (not sticky)	Makes GPIO signals sticky	
52h			all 0 (OFF)	Enables wake-up for each GPIO signal	
54h			= status of GPIO inputs	GPIO pin status (read from inputs, write '0' to clear sticky bits)	
	15	please refer to the register map		Controls Comparator 1 signal (virtual GPIO)	
	14			Controls Comparator 2 signal (virtual GPIO)	
	13			Controls Pen-Down Detector signal (virtual GPIO)	
	12			Controls ADA signal (virtual GPIO)	
	11			Controls Thermal sensor signal (virtual GPIO)	
	10			Controls Microphone short detect (virtual GPIO)	
	9			Controls Microphone insert detect (virtual GPIO)	
	8			Controls GPIO8 (pin 3)	
	7			Controls GPIO7 (pin 11)	
	6			Controls GPIO6 (pin 12)	
	5			Controls GPIO5 (pin 48)	
	4			Controls GPIO4 (pin 47)	
	3			Controls GPIO3 (pin 46)	
	2			Controls GPIO2 (pin 45)	
	1			Controls GPIO1 (pin 44)	

Register 4Ch to 54h control the GPIO pins and virtual GPIO signals.

REGISTER ADDRESS	BIT	LABEL	DEFAULT	DESCRIPTION	REFER TO
56h	8	GE8	1 (GPIO)	Selects between GPIO8 and SPDIF_OUT function for pin 12	GPIO and Interrupt Control
	7	GE7	1 (GPIO)	Selects GPIO7 function for pin 11	
	6	GE6	1 (GPIO)	Selects between GPIO6 and ADA/MASK functions for pin 3	
	5	GE5	1 (GPIO)	Selects between GPIO5 and SPDIF_OUT function for pin 48	
	4	GE4	1 (GPIO)	Selects between GPIO4 and ADA/MASK functions for pin 47	
	3	GE3	1 (GPIO)	Selects GPIO3 function for pin 46	
	2	GE2	1 (GPIO)	Selects between GPIO2 and IRQ function for pin 45	

Register 56h controls the use of GPIO pins for non-GPIO functions.

REGISTER ADDRESS	BIT	LABEL	DEFAULT	DESCRIPTION	REFER TO
58h	15:8	PU	01000000	Enables weak pull-up on GPIO pins (1=On)	GPIO and Interrupt Control
	7:0	PD	00000000	Enables weak pull-down on GPIO pins (1=On)	

Register 58h controls GPIO pull-up/down.

REGISTER ADDRESS	BIT	LABEL	DEFAULT	DESCRIPTION	REFER TO
5Ah	15:13	COMP2DEL	000 (no delay)	Selects Comparator 2 delay	Battery Alarm
	8	RSTDIS	0 (RESETB enabled)	Disables RESETB pin to enable use as a GPIO	GPIO Interrupt and Control
	7:6	JSEL	00 (GPIO1)	Selects GPIO for jack insert detect: 00: GPIO1 01: GPIO6 10: GPIO7 11: GPIO8	Jack Insertion & Auto-Switching
	5:4	HPMODE	00	HPF corner frequency 00: 7Hz @ Fs=48kHz 01: 82Hz @ Fs=16kHz 10: 82Hz @ Fs=8kHz 11: 170Hz @ Fs=8kHz	Audio ADCs
	3:2	DIE REV	Indicates device revision. 00=Rev.A, 01=Rev.B, 10=Rev.C		N/A
	1	WAKEEN	0 (no wake-up)	Enables GPIO wake-up	GPIO and Interrupt Control
	0	IRQ INV	0 (not inverted)	Inverts the IRQ signal (pin 45)	

Register 5Ah controls several additional functions.

REGISTER ADDRESS	BIT	LABEL	DEFAULT	DESCRIPTION	REFER TO
5Ch	15	AMUTE	0	Read-only bit to indicate DAC auto-muting	Audio DACs, Stereo DACs
	14	C1REF	0 (AVDD/2)	Selects Comparator 1 Reference Voltage	Battery Alarm
	13:12	C1SRC	00 (OFF)	Selects Comparator 1 Signal Source	
	11	C2REF	0 (AVDD/2)	Selects Comparator 1 Reference Voltage	
	10:9	C2SRC	00 (OFF)	Selects Comparator 1 Signal Source	
	7	AMEN	0 (OFF)	Enables DAC Auto-Mute	
	6:5	VBIAS	00	Selects analogue bias for lowest power, depending on AVDD supply. 0X=3.3V, 10=2.5V, 11=1.8V	Power Management
	4	ADCO	0	Selects source of SPDIF data. 0=from SDATAOUT, 1= from audio ADC	Digital Audio (SPDIF) Output
	3	HPF	0	Disables ADC high-pass filter	Audio ADC
1:0	ASS	00	Selects time slots for stereo ADC data. 00=slots 3 and 4, 01=7/8, 10=6/9, 11=10/11	Audio ADC, ADC Slot Mapping	

Register 5Ch controls several additional functions.

REGISTER ADDRESS	BIT	LABEL	DEFAULT	DESCRIPTION	REFER TO
60h	15:12	ALCL	1011 (-12dB)	Controls ALC threshold	Audio ADC, Automatic Level Control
	11:8	HLD	0000 (0 ms)	Controls ALC hold time	
	7:4	DCY	0011 (192 ms)	Controls ALC decay time	
	3:0	ATK	0010 (24 ms)	Controls ALC attack time	
62h	15:14	ALCSEL	00 (OFF)	Controls which channel ALC operates on. 00=none, 01=right only, 10=left only, 11=both	
	13:11	MAXGAIN	111 (+30dB)	Controls upper gain limit for ALC	
	10:9	ZC TIMEOUT	11 (slowest)	Controls time-out for zero-cross detection	
	8	ALCZC	0 (OFF)	Enables zero-cross detection for ALC	
	7	NGAT	0 (OFF)	Enables noise gate function	
	5	NGG	0 (hold gain)	Selects noise gate type. 0=hold gain, 1=mute	
	4:0	NGTH	00000 (-76.5dB)	Controls noise gate threshold	

Registers 60h and 62h control the ALC and Noise Gate functions.

REGISTER ADDRESS	BIT	LABEL	DEFAULT	DESCRIPTION	REFER TO
64h	15	XSLE	0	Selects input for AUXDAC. 0=from AUXDACVAL (for DC signals), 1=from AC-Link slot (for AC signals)	Auxiliary DAC
	14:12	AUXDACSLT	000 (Slot 5)	Selects input slot for AUXDAC (with XSLE=1)	
	11:0	AUXDACVAL	000000000	AUXDAC Digital Input for AUXDAC (with XSLE=0). 000h= minimum, FFFh=full-scale	

Register 64h controls the input signal of the auxiliary DAC.

REGISTER ADDRESS	BIT	LABEL	DEFAULT	DESCRIPTION	REFER TO
74h	9	POLL	0	Writing "1" initiates a measurement (when CTC is not set)	
	8	CTC	0	0=Polling mode; 1=Continuous mode (for DMA)	
	7	ADCSEL_AUX4	0	Enable COMP1/AUX4 measurement (pin32)	
	6	ADCSEL_AUX3	0	Enable COMP1/AUX3 measurement (pin31)	
	5	ADCSEL_AUX2	0	Enable COMP1/AUX2 measurement (pin30)	
	4	ADCSEL_AUX1	0	Enable COMP1/AUX1 measurement (pin29)	
76h	9:8	CR	00 (93.75Hz)	Controls conversion rate in continuous mode	AUX ADC Interface
	7:4	DEL	0000 (20.8µs)	Controls AUX ADC settling time	
	3	SLEN	1	Enables slot readback of AUX ADC data	
	2:0	SLT	110 (slot 11)	Selects time slot for readback of AUX ADC data	
78h	15:14	PRP	00	Selects mode of operation. 00=OFF, 11=running	
	9	WAIT	0	Controls data readback from register 7Ah. 0=overwrite old data with new, 1=wait until old data has been read	
	7:6	MSK	00 (OFF)	Controls MASK feature	
7Ah read only	14:12	ADCSRC	000 (none)	Indicates measurement type	
	11:0	ADCD	000h	Returns data from AUXADC	

Registers 76h, 78h and 7Ah control the AUX ADC interface.

WM9714L

Preliminary Technical Data

REGISTER ADDRESS	BIT	LABEL	DEFAULT	DESCRIPTION	REFER TO
7Ch	15:8	F7:0	57h	ASCII character "W" for Wolfson	Intel's AC'97 Component Specification, Revision 2.2, page 50
	7:0	S7:0	4Dh	ASCII character "M"	
7Eh	15:8	T7:0	4Ch	ASCII character "L"	
	7:0	REV7:0	12h	12 for WM9714L	

Register 7Ch and 7Eh are read-only registers that indicate to the driver that the codec is a WM9714L.

APPLICATIONS INFORMATION

RECOMMENDED EXTERNAL COMPONENTS

Recommended External Component Diagram -TBA

LINE OUTPUT

The headphone outputs, HPL and HPR, can be used as stereo line outputs. The speaker outputs, SPKL and SPKR, can also be used as line outputs. Recommended external components are shown below.

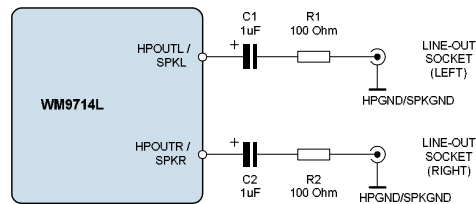

Figure 26 Recommended Circuit for Line Output

The DC blocking capacitors and the load resistance together determine the lower cut-off frequency, f_c . Assuming a 10 k Ω load and $C_1, C_2 = 10\mu\text{F}$:

$$f_c = 1 / 2\pi (R_L + R_1) \quad C_1 = 1 / (2\pi \times 10.1\text{k}\Omega \times 1\mu\text{F}) = 16 \text{ Hz}$$

Increasing the capacitance lowers f_c , improving the bass response. Smaller values of C_1 and C_2 will diminish the bass response. The function of R_1 and R_2 is to protect the line outputs from damage when used improperly.

AC-COUPLED HEADPHONE OUTPUT

The circuit diagram below shows how to connect a stereo headphone to the WM9714L.

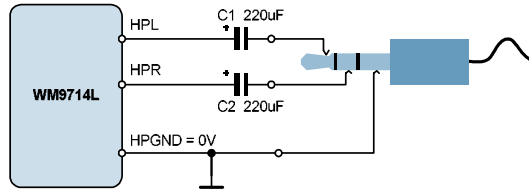

Figure 27 Simple Headphone Output Circuit Diagram

The DC blocking capacitors C1 and C2 together with the load resistance determine the lower cut-off frequency, f_c . Increasing the capacitance lowers f_c , improving the bass response. Smaller capacitance values will diminish the bass response. For example, with a 16Ω load and $C1 = 220\mu\text{F}$:

$$f_c = 1 / 2\pi R_L C_1 = 1 / (2\pi \times 16\Omega \times 220\mu\text{F}) = 45 \text{ Hz}$$

DC COUPLED (CAPLESS) HEADPHONE OUTPUT

In the interest of saving board space and cost, it may be desirable to eliminate the $220\mu\text{F}$ DC blocking capacitors. This can be achieved by using OUT3 as a headphone pseudo-ground, as shown below.

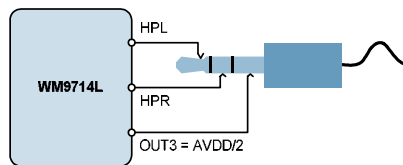

Figure 28 Capless Headphone Output Circuit Diagram

As the OUT3 pin produces a DC voltage of $AVDD/2$, there is no DC offset between HPL/HPR and OUT3, and therefore no DC blocking capacitors are required. However, this configuration has some drawbacks:

The power consumption of the WM9714L is increased, due to the additional power consumed in the OUT3 output buffer.

If the DC coupled output is connected to the line-in of a grounded piece of equipment, then OUT3 becomes short-circuited. Although the built-in short circuit protection will prevent any damage to the WM9714L, the audio signal will not be transmitted properly.

OUT3 cannot be used for another purpose

BTL LOUDSPEAKER OUTPUT

SPKL and SPKR can differentially drive a mono 8Ω loudspeaker as shown below.

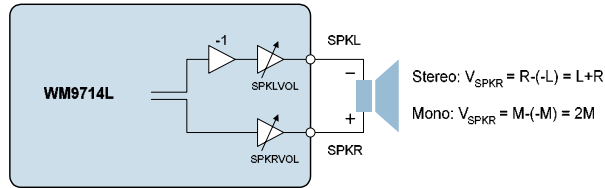

Figure 29 Speaker Output Connection (INV = 1)

To drive out differentially one of the speaker outputs must be inverted using INV1 or INV2.

COMBINED HEADSET / BTL EAR SPEAKER

In smartphone applications with a loudspeaker and separate ear speaker (receiver), a BTL ear speaker can be connected at the OUT3 pin, as shown below.

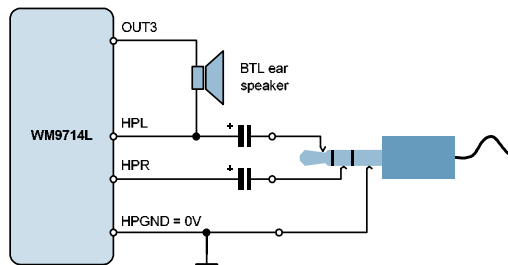

Figure 30 Combined Headset / BTL Ear Speaker

The ear speaker and the headset play the same signal. Whenever the headset is plugged in, the headphone outputs are enabled and OUT3 disabled. When the headset is not plugged in, OUT3 is enabled (see "Jack Insertion and Auto-Switching")

COMBINED HEADSET / SINGLE-ENDED EAR SPEAKER

Instead of a BTL ear speaker, a single-ended ear speaker can also be used, as shown below.

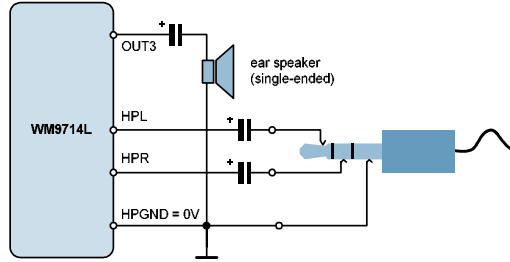

Figure 31 Combined Headset / Single-ended Ear Speaker

JACK INSERT DETECTION

The circuit diagram below shows how to detect when a headphone or headset has been plugged into the headphone socket. It generates an interrupt, instructing the controller to enable HPL and HPR and disable OUT3.

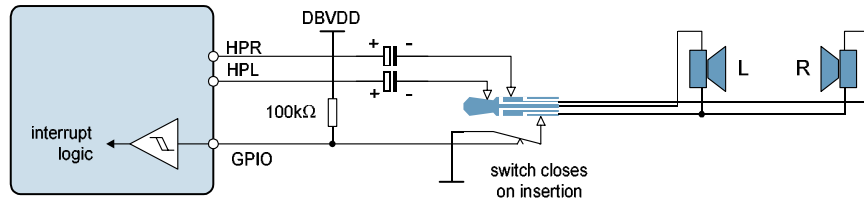

Figure 32 Jack Insert Detection Circuit

The circuit requires a headphone socket with a switch that closes on insertion. It detects both headphones and phone headsets. Any GPIO pin can be used, provided that it is configured as an input.

HOOKSWITCH DETECTION

Alternatively a headphone socket with a switch that opens on insertion can be used. For this mode of operation the GPIO input must be inverted.

The circuit diagram below shows how to detect when the "hookswitch" of a phone headset is pressed (pressing the hookswitch is equivalent to lifting the receiver in a stationary telephone).

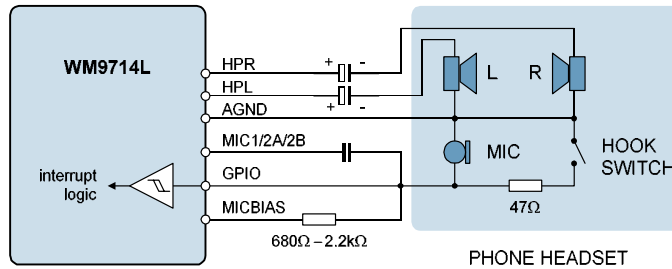

Figure 33

Hookswitch Detection Circuit

The circuit uses a GPIO pin as a sense input. The impedance of the microphone and the resistor in the MICBIAS path must be such that the potential at the GPIO pin is above $0.7 \times DBVDD$ when the hookswitch is open, and below $0.3 \times DBVDD$ when it is closed.

TYPICAL OUTPUT CONFIGURATIONS

The WM9714L has three outputs capable of driving loads down to 16Ω (headphone / line drivers) – HPL, HPR and MONO - and four output capable of driving loads down to 8Ω (loudspeaker / line drivers) – SPKL, SPKR, OUT3 and OUT4. The combination of output drivers, mixers and mixer inverters means that many output configurations can be supported. Below are some examples of typical output configurations for smartphone applications.

STEREO SPEAKER

Figure 34 shows a typical output configuration for stereo speakers with headphones, ear speaker and hands-free operation. The table shows suggested mixer outputs to select for each output PGA for a given operating scenario. (Note the inverted mixer outputs can be achieved using the mixer output inverters INV1 and INV2).

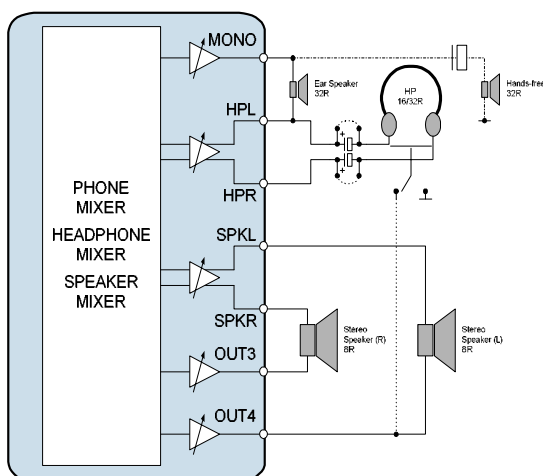

Config/ Driver	Hands-free (1:mmix)	Hands-free (2:spkmix)	Ear Speaker (1:mmix)	Ear Speaker (2:hpmix)	Ear Speaker (1) + Speaker	Ear Speaker (2) + Speaker	Stereo Speaker	Headphone
mono	mmix	spkmix	mmix	-hpmixR	mmix	-hpmixR	-	Z _H
spkl	-	-	-	-	hpmixL	hpmixL	hpmixL	(Z _H)
spkr	-	-	-	-	hpmixR	hpmixR	hpmixR	-
hpl	Z _H	Z _H	V _{mid}	hpmixL	V _{mid}	hpmixL	-	hpmixL
hpr	-	-	-	-	-	-	-	hpmixR
out3	-	-	-	-	-hpmixR	-hpmixR	-hpmixR	-
out4	-	-	-	-	-hpmixL	-hpmixL	-hpmixL	(V _{mid})

Figure 34 Stereo Speaker Output Configuration

MONO SPEAKER

Figure 35 shows a typical output configuration for mono speaker with headphones, ear speaker and hands-free operation. The table shows suggested mixer outputs to select for each output PGA for a given operating scenario. (Note the inverted mixer outputs can be achieved using the mixer output inverters INV1 and INV2).

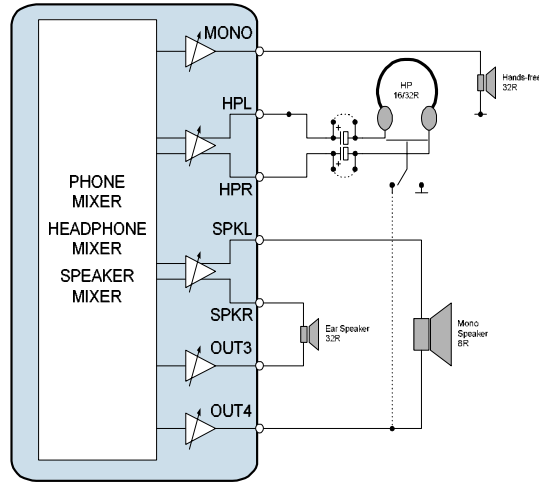

Config/ Driver	Hands-free (1:mmix)	Hands-free (2:spkmix)	Ear Speaker (1:mmix)	Ear Speaker (2:hpmix)	Ear Speaker (1) + Speaker	Ear Speaker (2) + Speaker	Mono Speaker	Headphone
mono	mmix	spkmix	-	-	-	-	-	-
spkl	-	-	-	-	hpmixL	hpmixL	spkmix	(Z4)
spkr	-	-	mmix	hpmixR	mmix	hpmixR	-	-
hpl	-	-	-	-	-	-	-	hpmixL
hpr	-	-	-	-	-	-	-	hpmixR
out3	-	-	-mmix	-hpmixL	-mmix	-hpmixL	-	-
out4	-	-	-	-	-hpmixR	-hpmixR	-spkmix	(Vmid)

Figure 35 Mono Speaker Output Configuration

WM9714L MONO SPEAKER

Figure 36 shows a typical output configuration compatible with the WM9712 for mono speaker with headphones, ear speaker and hands-free operation. The table shows suggested mixer outputs to select for each output PGA for a given operating scenario. (Note the inverted mixer outputs can be achieved using the mixer output inverters INV1 and INV2).

When using this configuration note that AVDD, HPVDD and SPKVDD must all be at the same voltage to achieve the best performance.

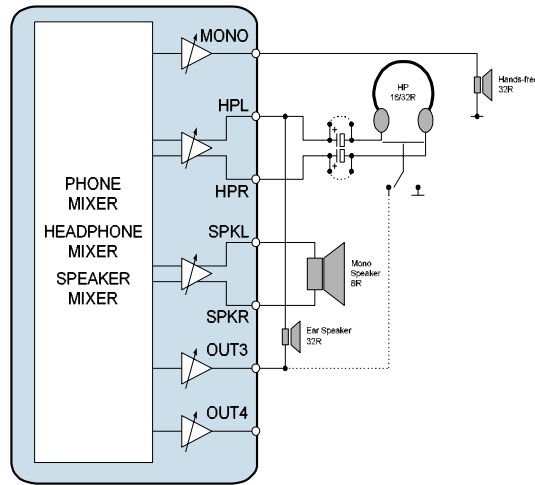

Config/ Driver	Hands-free (1:mmix)	Hands-free (2:spkmix)	Ear Speaker (1:mmix)	Ear Speaker (2:hpmix)	Ear Speaker (1) + Speaker	Ear Speaker (2) + Speaker	Mono Speaker	Headphone
mono	mmix	spkmix	-	-	-	-	-	-
spkl	-	-	-	-	hpmixL	hpmixL	spkmix	-
spkr	-	-	-	-	-hpmixR	hpmixR	-spkmix	-
hpl	-	-	V _{mid}	hpmixL	mmix	hpmixL	-	hpmixL
hpr	-	-	-	-	-	-	-	hpmixR
out3	-	-	mmix	-hpmixR	-mmix	-hpmixR	-	(Zt)
out4	-	-	-	-	-	-	-	-

Figure 36 WM9714L Mono Speaker Configuration

PACKAGE DIMENSIONS

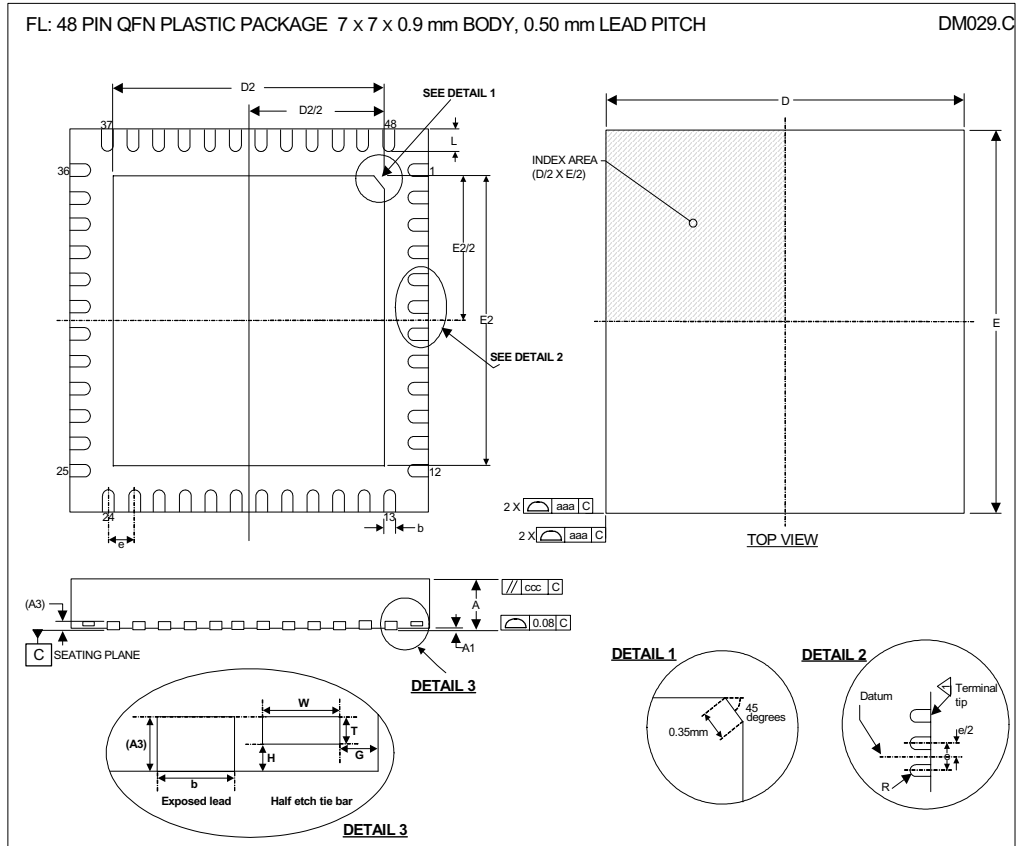

Symbols	Dimensions (mm)			NOTE
	MIN	NOM	MAX	
A	0.80	0.90	1.00	
A1	0	0.02	0.05	
A3		0.20 REF		
b	0.18	0.25	0.30	1
D		7.00 BSC		
D2	5.00	5.15	5.25	
E		7.00 BSC		
E2	5.00	5.15	5.25	
e		0.5 BSC		
G		0.213		
H		0.1		
L	0.30	0.4	0.50	
T		0.1		
W		0.2		
Tolerances of Form and Position				
aaa	0.15			
bbb	0.10			
ccc	0.10			
REF	JEDEC, MO-220, VARIATION VKKD-2			

- NOTES:
1. DIMENSION b APPLIED TO METALLIZED TERMINAL AND IS MEASURED BETWEEN 0.15 mm AND 0.30 mm FROM TERMINAL TIP.
 2. ALL DIMENSIONS ARE IN MILLIMETRES
 3. THE TERMINAL #1 IDENTIFIER AND TERMINAL NUMBERING CONVENTION SHALL CONFORM TO JESD 95-1 SPP-002.
 4. COPLANARITY APPLIES TO THE EXPOSED HEAT SINK SLUG AS WELL AS THE TERMINALS.
 5. THIS DRAWING IS SUBJECT TO CHANGE WITHOUT NOTICE.

IMPORTANT NOTICE

Wolfson Microelectronics plc (WM) reserve the right to make changes to their products or to discontinue any product or service without notice, and advise customers to obtain the latest version of relevant information to verify, before placing orders, that information being relied on is current. All products are sold subject to the WM terms and conditions of sale supplied at the time of order acknowledgement, including those pertaining to warranty, patent infringement, and limitation of liability.

WM warrants performance of its products to the specifications applicable at the time of sale in accordance with WM's standard warranty. Testing and other quality control techniques are utilised to the extent WM deems necessary to support this warranty. Specific testing of all parameters of each device is not necessarily performed, except those mandated by government requirements.

In order to minimise risks associated with customer applications, adequate design and operating safeguards must be used by the customer to minimise inherent or procedural hazards. Wolfson products are not authorised for use as critical components in life support devices or systems without the express written approval of an officer of the company. Life support devices or systems are devices or systems that are intended for surgical implant into the body, or support or sustain life, and whose failure to perform when properly used in accordance with instructions for use provided, can be reasonably expected to result in a significant injury to the user. A critical component is any component of a life support device or system whose failure to perform can be reasonably expected to cause the failure of the life support device or system, or to affect its safety or effectiveness.

WM assumes no liability for applications assistance or customer product design. WM does not warrant or represent that any license, either express or implied, is granted under any patent right, copyright, mask work right, or other intellectual property right of WM covering or relating to any combination, machine, or process in which such products or services might be or are used. WM's publication of information regarding any third party's products or services does not constitute WM's approval, license, warranty or endorsement thereof.

Reproduction of information from the WM web site or datasheets is permissible only if reproduction is without alteration and is accompanied by all associated warranties, conditions, limitations and notices. Representation or reproduction of this information with alteration voids all warranties provided for an associated WM product or service, is an unfair and deceptive business practice, and WM is not responsible nor liable for any such use.

Resale of WM's products or services with statements different from or beyond the parameters stated by WM for that product or service voids all express and any implied warranties for the associated WM product or service, is an unfair and deceptive business practice, and WM is not responsible nor liable for any such use.

ADDRESS:

Wolfson Microelectronics plc
Westfield House
Westfield Road
Edinburgh
EH11 2QB
United Kingdom

Tel :: +44 (0)131 272 7000

Fax :: +44 (0)131 272 7001

Email :: sales@wolfsonmicro.com