

Micropower Voltage Reference

FEATURES

- Low Output Voltage 1.235V
- Dynamic Impedance.....1Ω max
- Low Temperature Coefficient.....30ppm/°C (typ)
- Operating Current 10μA to 20mA
- Extended Temperature Range .. -40°C to +85°C
- Initial Tolerance.....1% and 2%
- Pin Compatible with LM185/285/385, 1.23V

APPLICATIONS

- Portable Meter Reference
- Portable Test Instruments
- Battery Operated Systems
- Panel Meters



Now Available in Lead Free Packaging

DESCRIPTION

The SPX385-1.2 is a micropower 2-terminal band-gap voltage reference with a very wide operating current range from 10μA to 20mA that provides a stable voltage. The high stability of this device is primarily the result of the low temperature coefficient Thin Film Resistor process and Laser Trimming of the output voltage at the wafer level.

The SPX385-1.2 is available in a TO-92, SOIC-8 and SOT-89 package with an operating temperature range of -40°C to 85°C. A 2.5 and 5.0 volt devices are also available - SPX385-2.5, SPX385-5.0.

BLOCK DIAGRAM

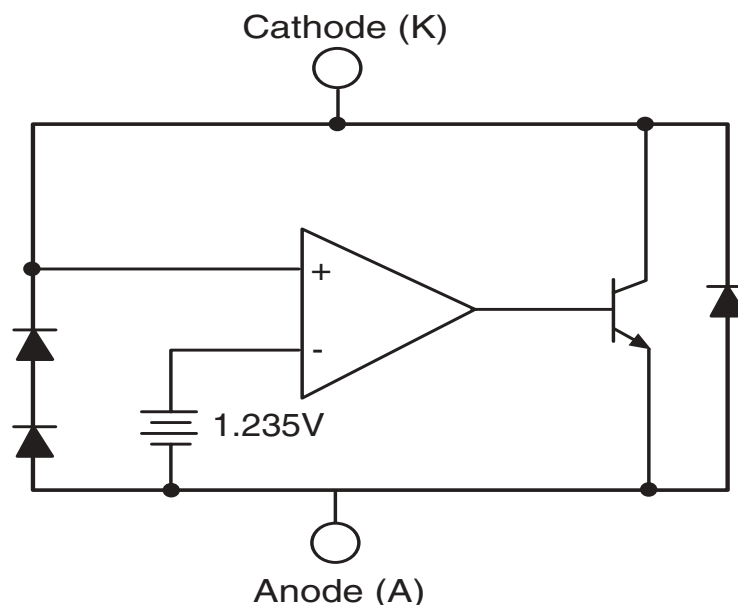

Figure 1: Block Diagram

ABSOLUTE MAXIMUM RATINGS

Reverse Current (I_{KA})	30mA
Forward Current (I_{AK})	10mA
Operating Temperature Range (T_A)	-40 to +85°C
Continuous Power Dissipation at 25°C (P_D)	
TO-92	775mW
SOIC-8	750mW
SOT-89	1000mW
Junction Temperature (T_J)	150°C
Storage Temperature (T_{STG})	- 65 to 150°C
Lead Temperature (Soldering 10 sec.), T_L	300°C

Stresses greater than those listed under ABSOLUTE MAXIMUM RATINGS may cause permanent damage to the device. This is a stress rating only and functional operation of the device at these or any other conditions above those indicated in the operational sections of this specification is not implied. Exposure to absolute maximum rating conditions for extended periods may affect reliability.

TYPICAL THERMAL RESISTANCES

PACKAGE	θ_{JA}	θ_{JA}	TYPICAL DERATING
TO-92	160°C/W	80°C/W	6.3 mW/°C
SOIC-8	175°C/W	45°C/W	5.7mW/°C
SOT-89	110°C/W	8°C/W	9.1mW/°C

ELECTRICAL CHARACTERISTICS

$I_{IN} = 100\mu A$, $T_A = 25^\circ C$, unless otherwise specified.

PARAMETER	CONDITIONS	SPX385A-1.2			SPX385-1.2			UNIT
		MIN.	TYP.	MAX.	MIN.	TYP.	MAX.	
Reference Voltage		1.223	1.235	1.247	1.205	1.235	1.260	V
Dynamic Output Impedance	$F = 20\text{Hz}$ $I_R = 100\mu A$		0.6	1.0		0.6	1.0	Ω
Reference Voltage Change with I_R	$10\mu A \leq I_R \leq 20\text{mA}$		10	20		10	20	mV
Temperature Coefficient	Note 1		30	50		30	50	ppm/°C
Minimum Operating Current			8	10		8	10	μA
Output Wideband Noise	$10\text{Hz} \leq f \leq 10\text{kHz}$		60			60		μV_{rms}
Operating Temperature		-40		+85	-40		+85	°C

Note 1. Three-point measurement guarantees the error band over the specified temperature range.

* CALCULATING AVERAGE TEMPERATURE COEFFICIENT (TC)

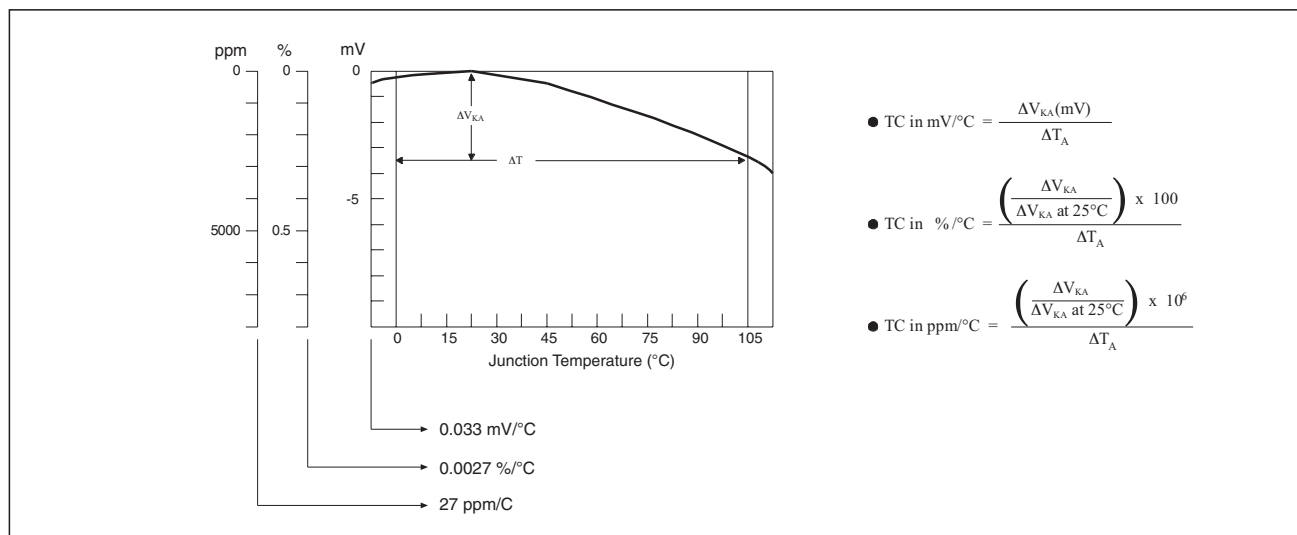

Figure 2. V_{REF} vs. Temperature

TYPICAL PERFORMANCE CHARACTERISTICS

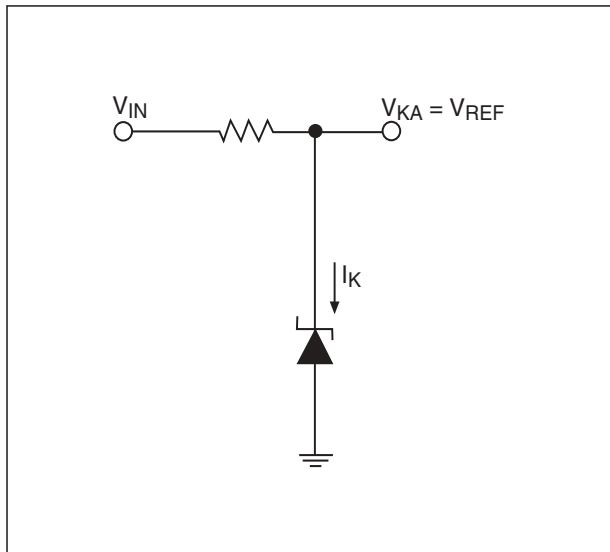

Figure 3. Test Circuit for $V_{KA} = V_{REF}$

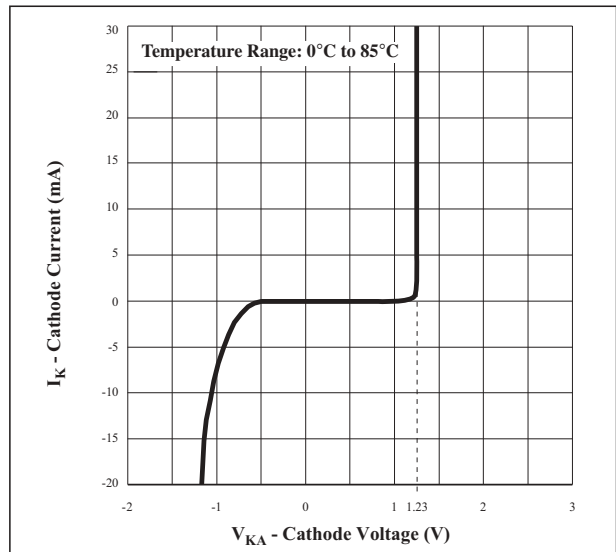

Figure 4. High Current Operating Characteristics

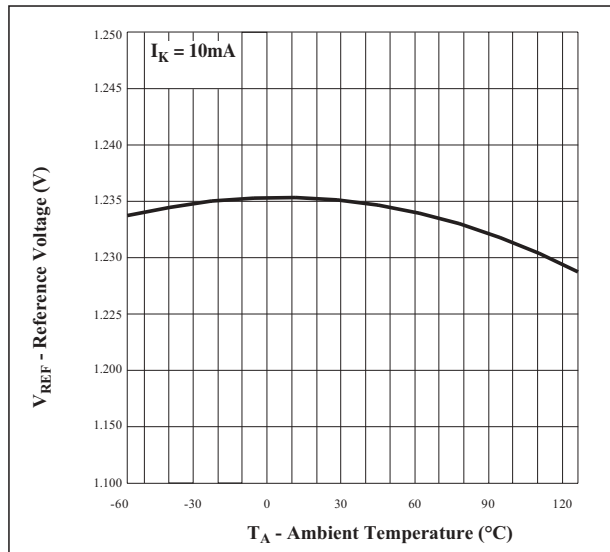

Figure 5. Reference Voltage vs. Ambient Temperature

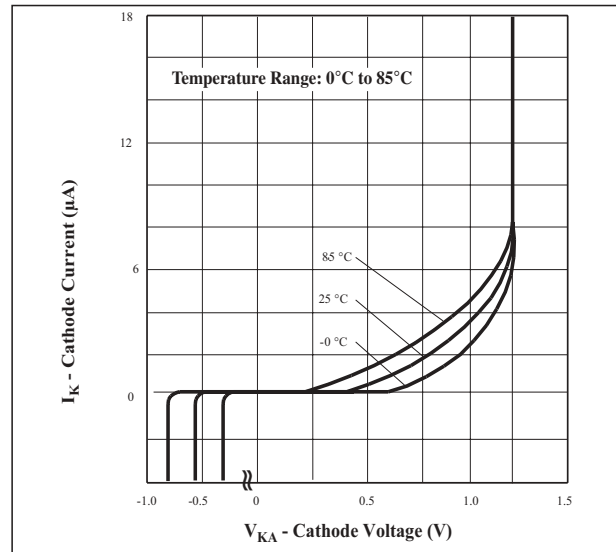

Figure 6. Low Current Operating Characteristics

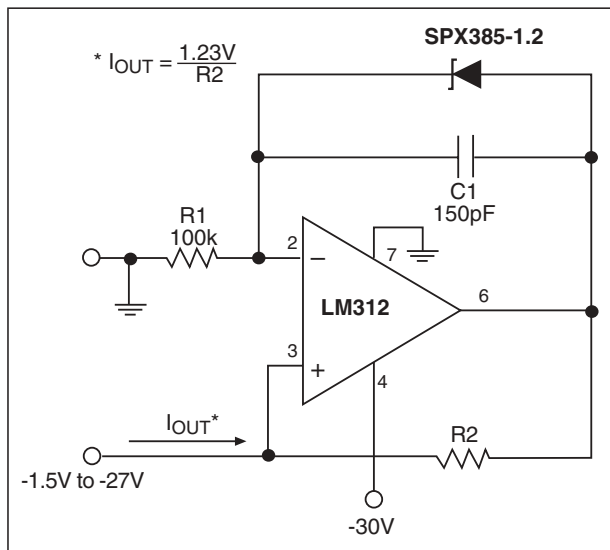

Figure 7a. Precision $1\mu\text{A}$ to 1mA Current Sink

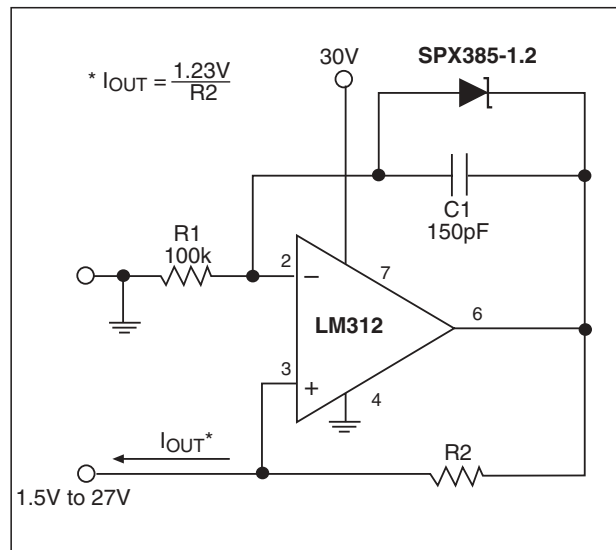

Figure 7b. Precision $1\mu\text{A}$ to 1mA Current Source

TYPICAL PERFORMANCE CHARACTERISTICS

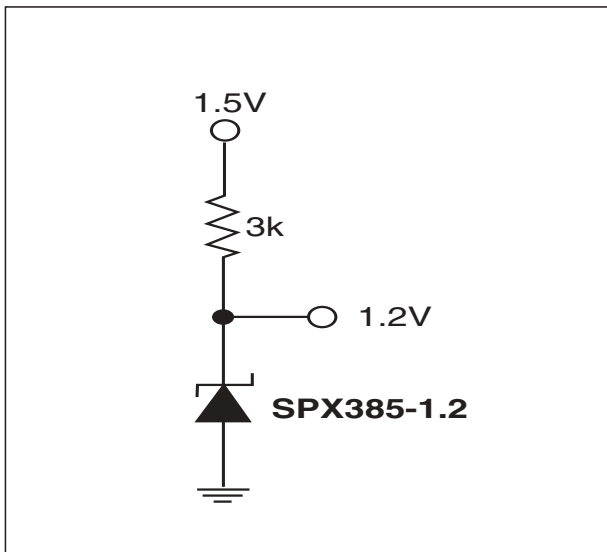

Figure 8. Reference from 1.5V Battery

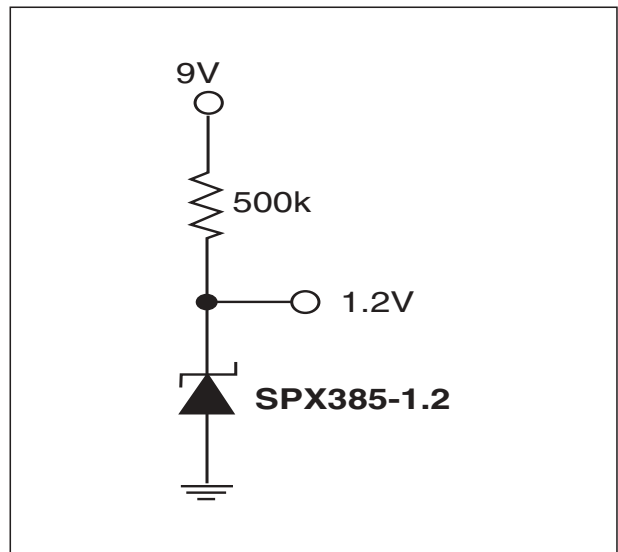

Figure 9. Micropower Reference from 9V Battery

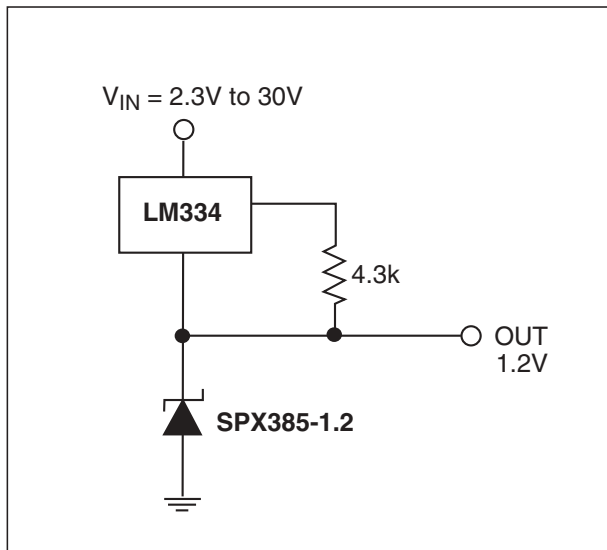

Figure 10. Wide Input Range Reference

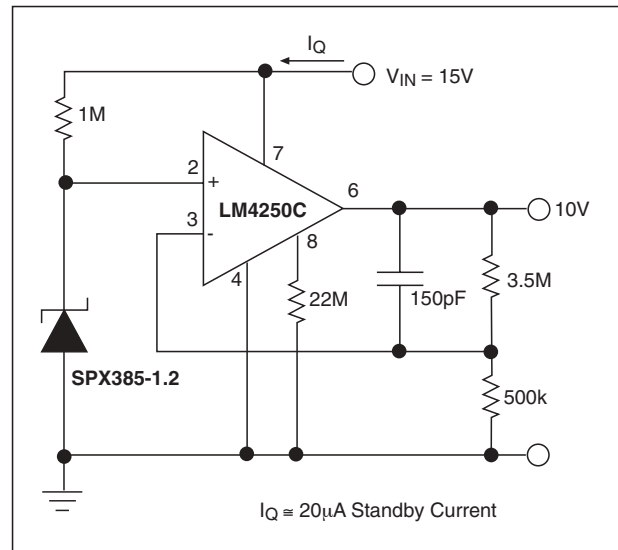
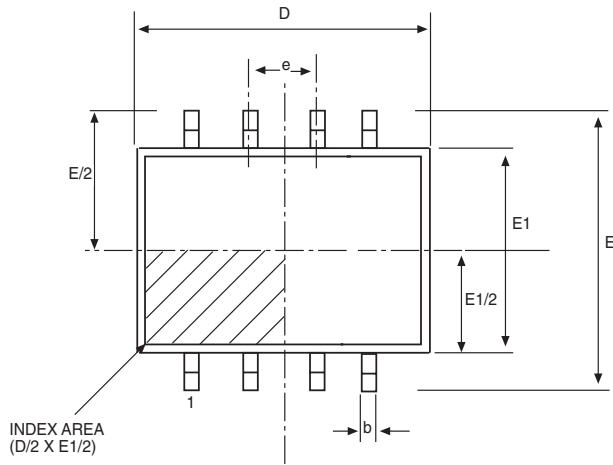
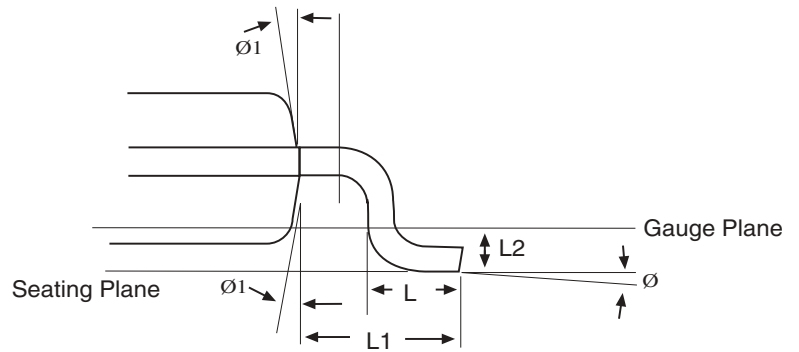
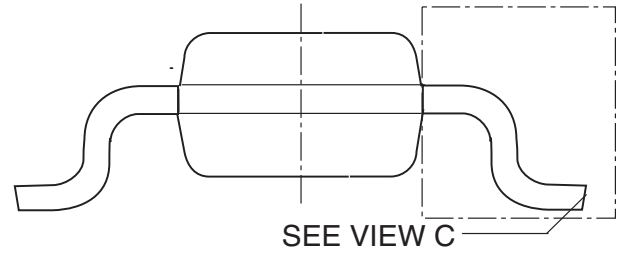

Figure 11. Precision Micropower 10V Reference



TOP VIEW



VIEW C

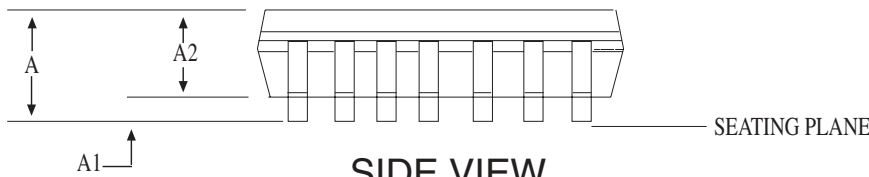

SIDE VIEW

8 Pin NSOIC (JEDEC MS-012, AA - VARIATION)	DIMENSIONS Minimum/Maximum (mm)		
COMMON HEIGHT DIMENSION			
SYMBOL	MIN	NOM	MAX
A	1.35	-	1.75
A1	0.10	-	0.25
A2	1.25	-	1.65
b	0.31	-	0.51
c	0.17	-	0.25
D	4.90 BSC		
E	6.00 BSC		
E1	3.90 BSC		
e	1.27 BSC		
L	0.40	-	1.27
L1	1.04 REF		
L2	0.25 BSC		
Ø	0°	-	8°
Ø1	5°	-	15°

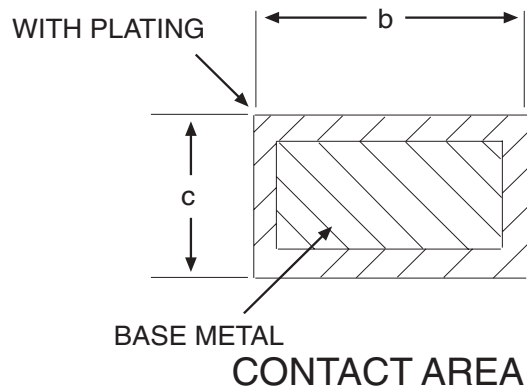

8 PIN NSOIC

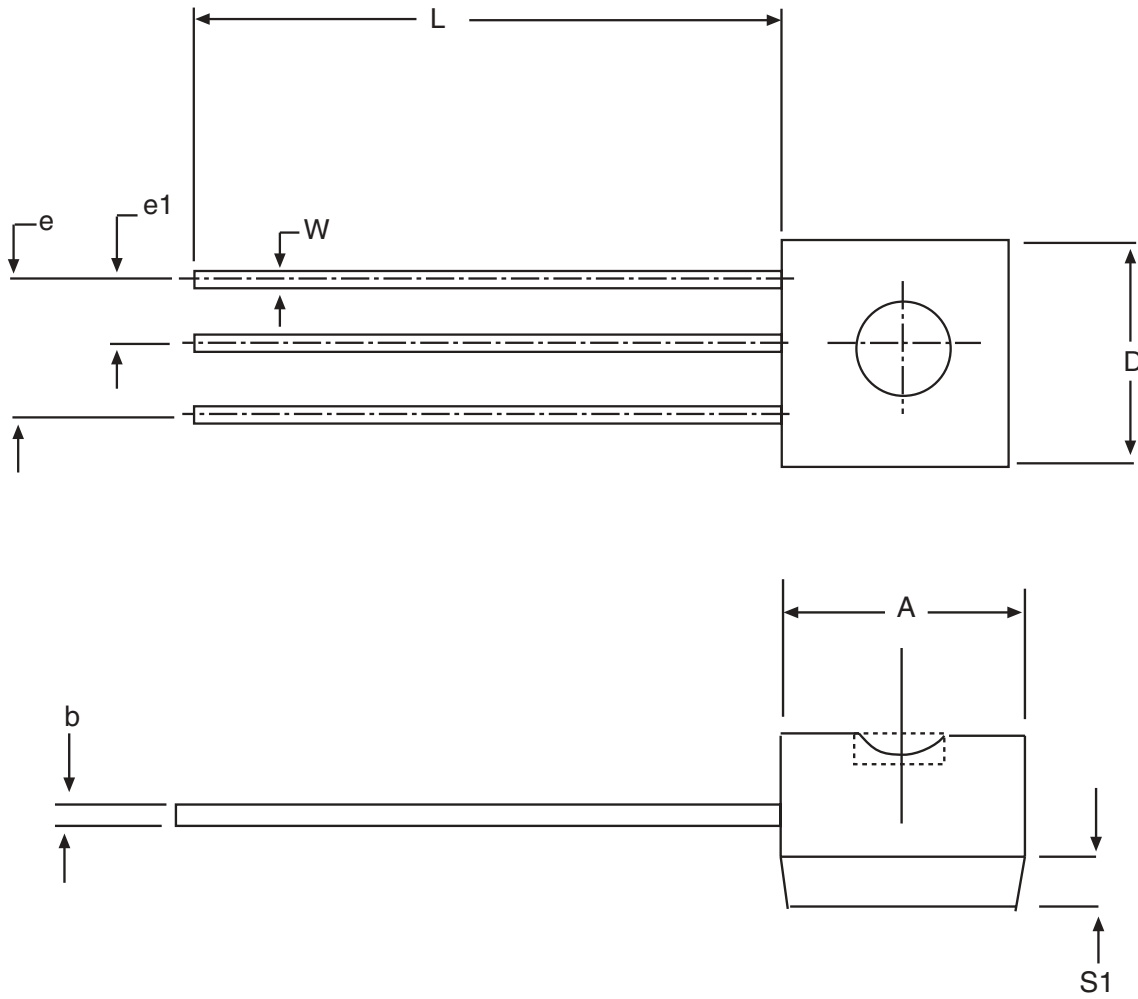

3 PIN TO-92 CARSEM DWG # TLG920001		DIMENSIONS Minimum/Maximum (mm)		
COMMON HEIGHT DIMENSION				
SYMBOL	MIN	NOM	MAX	
A	4.32	-	4.95	
b	0.36	-	0.51	
E	3.30	-	3.94	
e	2.41	-	2.67	
e1	1.14	-	1.40	
L	12.70	-	15.49	
R	2.16	-	2.41	
S1	1.14	-	1.52	
W	0.41	-	0.56	
D	4.45	-	4.95	
∂	4°	-	6°	

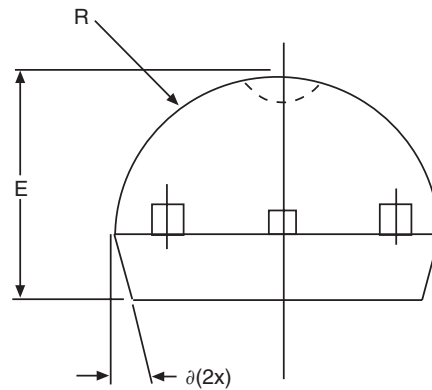

3 PIN TO-92

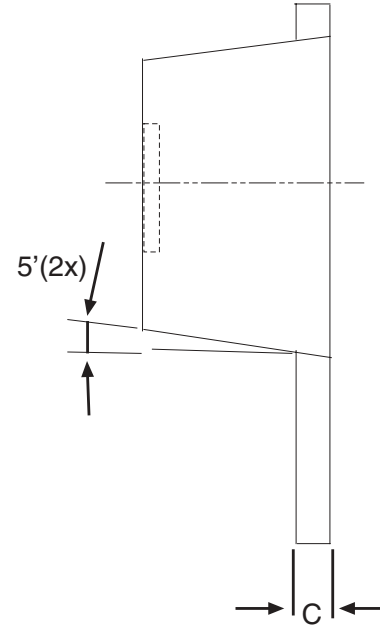
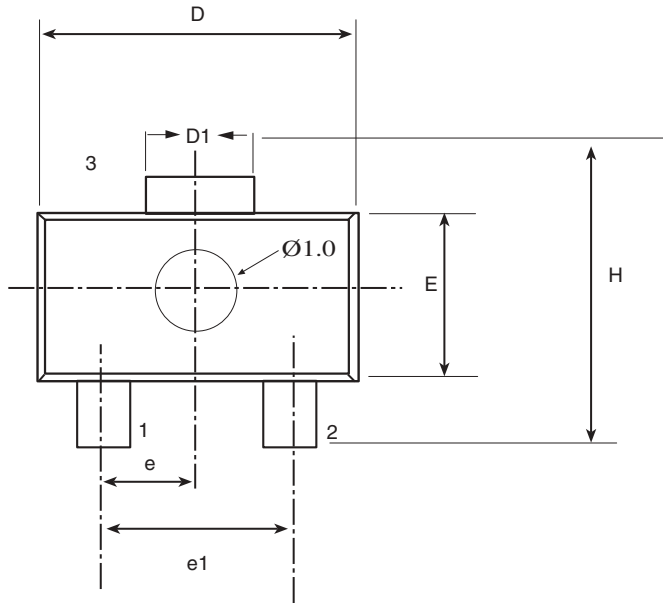

3 PIN SOT-89 LINGSEN # PO-SOT-004	Dimensions in (mm)		
	MIN	NOM	MAX
A	1.40	1.50	1.60
b	0.36	0.42	0.48
b1	0.41	0.47	0.53
C	0.38	0.40	0.43
D	4.40	4.50	4.60
D1	1.40	1.60	1.75
E	2.40	2.50	2.60
e	1.45	1.50	1.55
e1	2.90	3.00	3.10
H	3.94	-	4.25
L	0.80	-	1.20

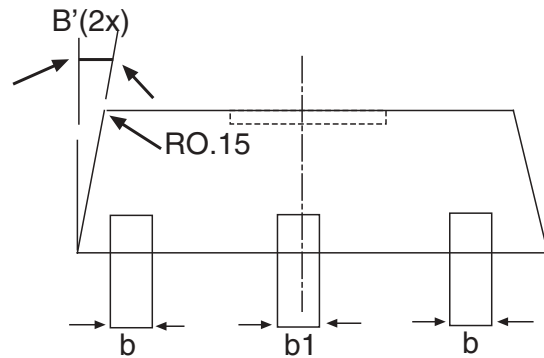

3 PIN SOT-89

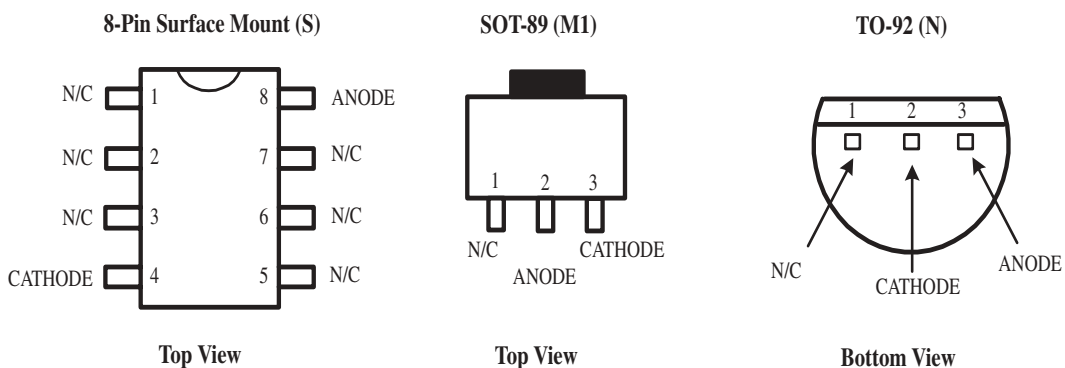

ORDERING INFORMATION

Part Number	Accuracy	Output Voltage	Package Type
SPX385AM1-1.2	1.0%	1.235V	3-Pin SOT-89
SPX385AM1-1.2/TR	1.0%	1.235V	3-Pin SOT-89
SPX385AS-1.2	1.0%	1.235V	8-Pin NSOIC
SPX385AS-1.2/TR	1.0%	1.235V	8-Pin NSOIC
SPX385AN-1.2	1.0%	1.235V	3-Pin TO-92
SPX385AN-1.2/TR	1.0%	1.235V	3-Pin TO-92
SPX385M1-1.2	2.0%	1.235V	3-Pin SOT-89
SPX385M1-1.2/TR	2.0%	1.235V	3-Pin SOT-89
SPX385S-1.2	2.0%	1.235V	8-Pin NSOIC
SPX385S-1.2/TR	2.0%	1.235V	8-Pin NSOIC
SPX385N-1.2	2.0%	1.235V	3-Pin TO-92
SPX385N-1.2/TR	2.0%	1.235V	3-Pin TO-92

Available in lead free packaging. To order add "-L" suffix to part number.

Example: SPX385S-1.2/TR = standard; SPX385S-L-1.2/TR = lead free

/TR = Tape and Reel

Pack quantity is 2000 for TO-92; 2500 for NSOIC and SOT-89.



ANALOG EXCELLENCE

Sipex Corporation

Headquarters and Sales Office:
 233 Hillview Dr
 Milpitas, CA 95035
 TEL: (408) 934-7500
 FAX: (408) 935-7600

Sipex Corporation reserves the right to make changes to any products described herein. Sipex does not assume any liability arising out of the application or use of any product or circuit described herein; neither does it convey any license under its patent rights nor the rights of others.