

Features

- Supports AT&T TR62411 Stratum 3, 4 and Stratum 4 Enhanced for DS1 interfaces and for ETSI ETS 300 011, TBR 4, TBR 12, and TBR 13 for E1 interfaces
- Supports ITU-T G.812 Type IV clocks for 1.544kbit/s interfaces and 2.048kbit/s interface
- Provides C1.5, C3, C2, C4, C8, C6, C16 and C19 output clock signals
- Provides five kinds of 8kHz ST-BUS framing signals
- Two independent reference inputs
- Input reference frequency 1.544MHz, 2.048MHz or 8kHz selectable
- Provides bit error free reference switching and meets phase slope and MTIE requirements
- Normal, Holdover or Free-Run operating modes available
- Automatic reference input impairment monitor
- Power supply: 5V (4409) and 3.3V(4409L)

Applications

- Synchronization and timing control for multitrunk T1 and E1 systems, STS-3/OC3 systems
- ST-BUS clock and frame pulse sources
- Primary Trunk Rate Converters

Description

PT7A4409/4409L employs a digital phase-locked loop (DPLL) to provide timing and synchronizing signals for multitrunk T1 and E1 primary rate transmission links, and for STS-3/OC3 links. The ST-BUS clock and framing signals are phase-locked to input reference signals of either 2.048 MHz, 1.544MHz or 8 kHz.

The PT7A4409/4409L meets the requirements for AT&T TR62411 Stratum 3, 4 and Stratum 4 Enhanced, and ETSI ETS 300 011 in jitter tolerance, jitter transfer, intrinsic jitter, frequency accuracy, holdover accuracy, capture range, phase slope and MTIE, etc.

The PT7A4409/4409L operates in Manual or Automatic Mode, and in each of the modes, three operating states are available: Normal, Holdover and Free-Run.

Ordering Information

Part Number	Package
PT7A4409J	44-Pin PLCC
PT7A4409LJ	44-Pin PLCC
PT7A4409JE	Lead free 44-Pin PLCC
PT7A4409LJE	Lead free 44-Pin PLCC

Contents

Features	1
Applications	1
Description	1
Ordering Information	1
Block Diagram	3
Pin Information	4
Pin Assignment	4
Pin Configuration	4
Pin Description	5
Functional Description	7
Overall Operation	7
Modes and States of Operation	10
Applications Information	14
Detailed Specifications	16
Definitions of Critical Performance Specifications	16
Absolute Maximum Ratings	18
Recommended Operating Conditions	18
DC Electrical and Power Supply Characteristics	19
AC Electrical Characteristics	20
Mechanical Specifications	33
Note	34

Block Diagram

Figure 1. Block Diagram

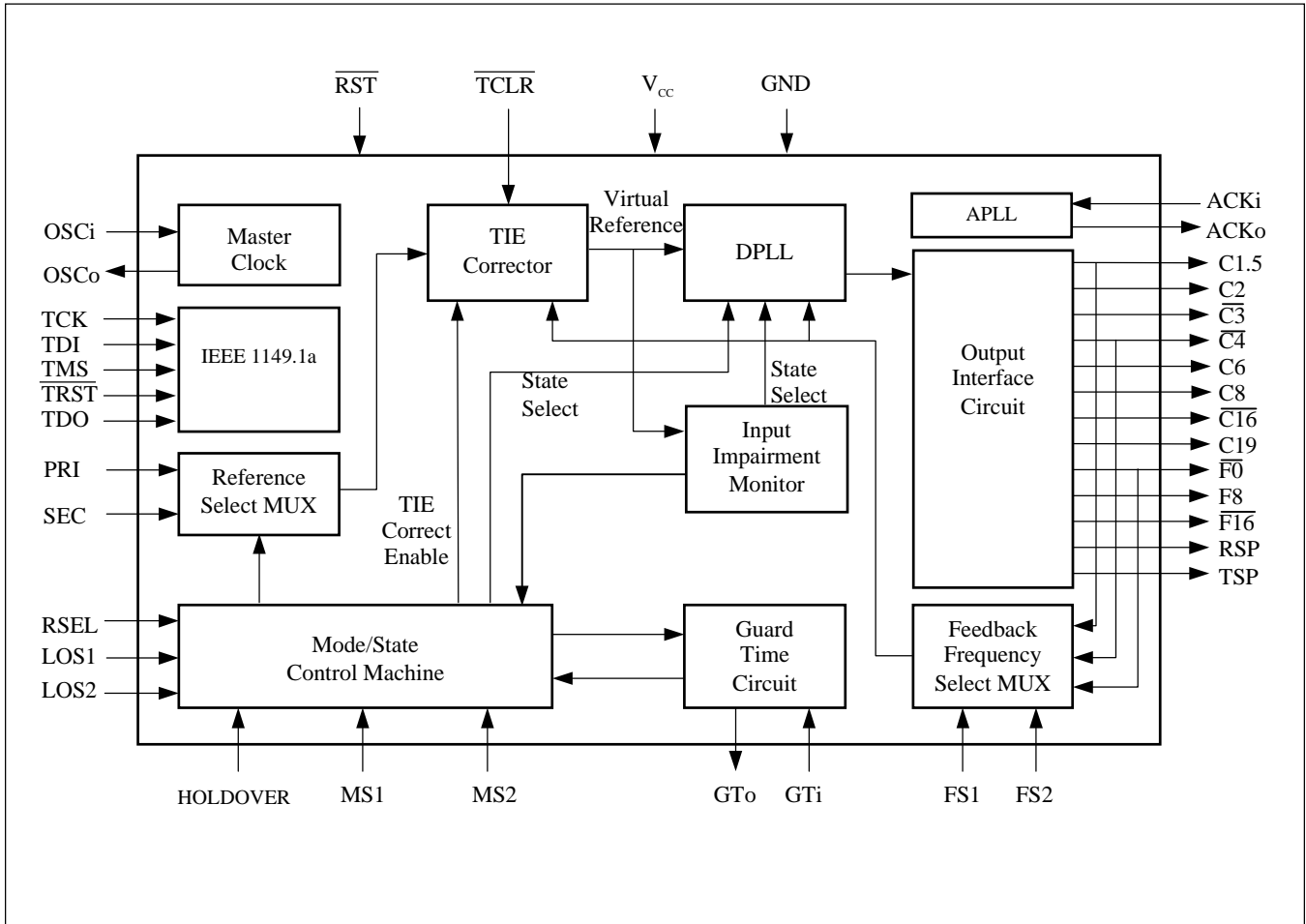

Pin Information

Pin Assignment

Table 1. Pin Assignment

Group	Symbol	Function
Chip Clock	OSCi, OSCo, ACKi, ACKo	Clock
Power & Ground	V _{CC} , GND, AVDD, AGND	Power
Clock and Framing Outputs	C1.5, $\overline{C3}$, C2, $\overline{C4}$, C6, C8, $\overline{C16}$, C19, $\overline{F0}$, F8, $\overline{F16}$, RSP, TSP	Clock and Framing Signals
Control Signals	RSEL, LOS1, LOS2, MS1, MS2, GTi, GTo, FS1, FS2, RST, \overline{TCLR}	Control
Reference Inputs	PRI, SEC	Reference Clock
IEEE 1149.1a	TCK, TDI, TMS, \overline{TRST} , TDO	IEEE 1149.1a Interface

Pin Configuration

Figure 2. Pin Configuration

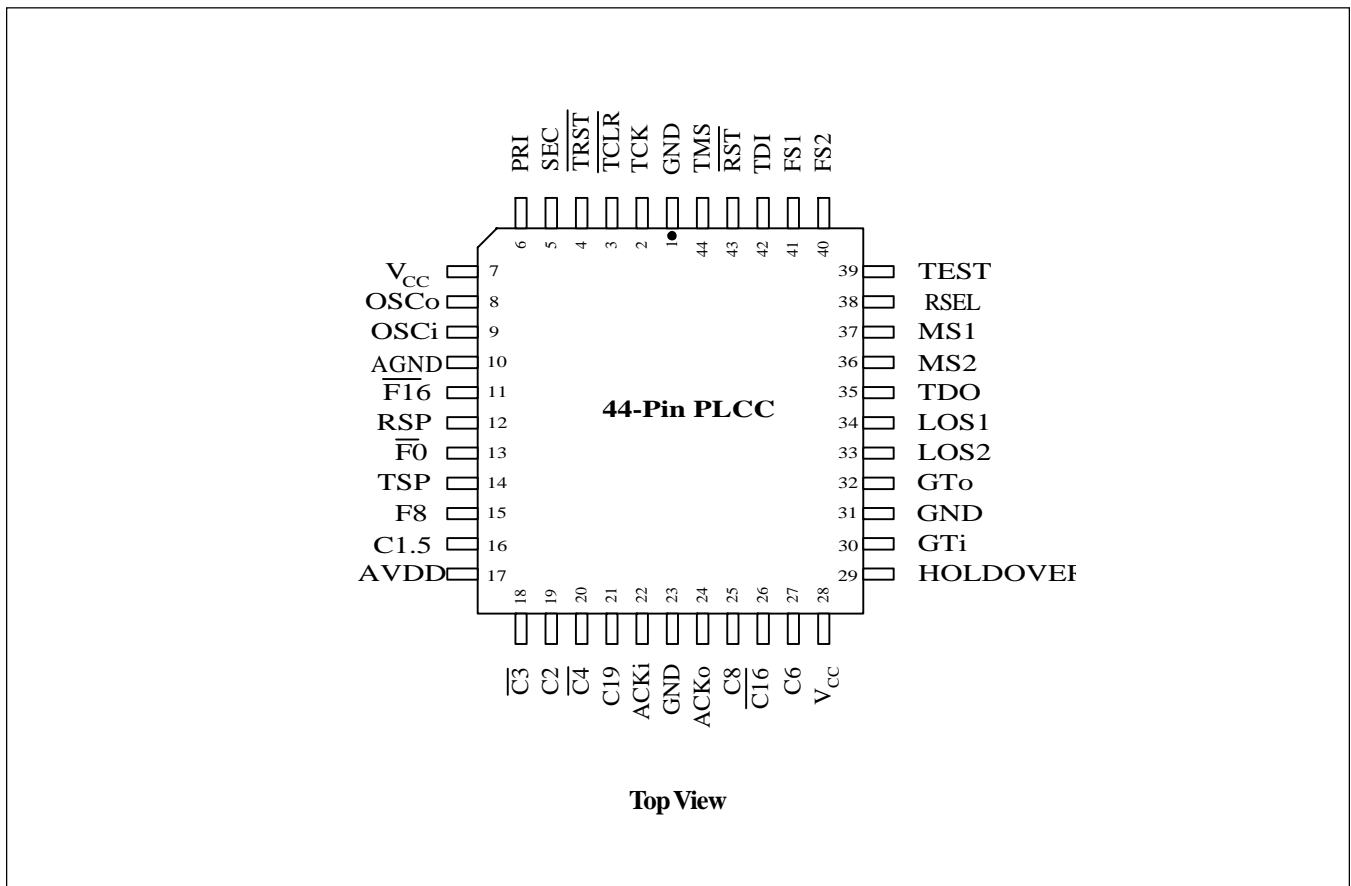

Pin Description

Table 2. Pin Description

Pin	Name	Type	Description
1, 23, 31	GND	Ground	Digital Ground (0V)
10	AGND	Ground	Analog Ground
2	<u>TCK</u>	I	Test Clock (TTL Input): Provides the clock to the JTAG test logic. This pin is internally pulled up to V_{CC} .
3	TCLR	I	TIE circuit reset (TTL): A low level on this pin will reset the TIE circuit, re-aligning the output signals with the input signal. TCLR must be active (low) for at least 300ns. This pin is internally pulled down to GND.
4	TRST	I	Test Reset (TTL Input): Asynchronously initializes the JTAG TAP controller by putting it in the Test-Logic-Reset state. This pin is internally pulled down to GND.
5	SEC	I	Secondary reference (TTL): One of two independent input reference signals, internally pulled down to GND.
6	PRI	I	Primary reference (TTL): The other independent reference signal, internally pulled down to GND.
7, 28	V_{CC}	Power	Power supply +5V DC for PT7A4409J. +3.3V DC for PT7A4409LJ
8	OSCo	O	Oscillator master clock output (CMOS): Output of 20MHz master clock
9	OSCi	I	Oscillator master clock input (CMOS): Input of 20MHz master clock (can be connected directly to a clock source)
11	F16	O	Frame pulse ST-BUS 16.384Mb/s (CMOS): 8kHz frame signal with 61ns low level pulse that marks the beginning of a ST-BUS frame, typically used for ST-BUS operation at 8.192Mb/s. See figure 18.
12	RSP	O	Receive Sync Pulse (CMOS Output). This is an 8kHz 488ns active high framing pulse, which marks the end of an ST-BUS frame. See Figure 19.
13	F0	O	Frame pulse ST-BUS 2.048 Mb/s (CMOS): 8kHz frame signal with 244ns low level pulse that marks the beginning of a ST-BUS frame e, typically used for ST-BUS operation at 2.048Mb/s. See figure 18.
14	TSP	O	Transmit Sync Pulse (CMOS Output). This is an 8kHz 488ns active high framing pulse, which marks the beginning of an ST-BUS frame. See Figure 19.
15	F8	O	Frame pulse ST-BUS 8.192 Mb/s (CMOS): 8kHz frame signal with 122ns high level pulse that marks the beginning of a ST-BUS frame
16	CT.5	O	1.544 MHz clock (CMOS): This output is used in T1 applications.
17	AVDD	Power	Analog Power Supply: +5V DC for PT7A4409J. +3.3V DC for PT7A4409LJ
18	€3	O	3.088 MHz clock (CMOS): This output is used in T1 applications.
19	C2	O	2.048 MHz clock (CMOS): This output is used for ST-BUS operation at 2.048Mb/s.
20	C4	O	4.096 MHz clock (CMOS): This output is used for ST-BUS operation at 2.048Mb/s and 4.096Mb/s.
21	C19	O	Clock 19.44MHz (CMOS Output). This output is used in OC3/STS3 applications.
22	ACKi	I	Analog PLL Clock Input (CMOS Input). This input clock is a reference for an internal analog PLL. This pin is internally pulled down to GND.
24	ACKo	O	Analog PLL Clock Output (CMOS Output). This output clock is generated by the internal analog PLL.

Table 2. Pin Description (continued)

Pin	Name	Type	Description
25	C8	O	8.192 MHz clock (CMOS): This output is used for ST-BUS operation at 8.192Mb/s.
26	$\overline{C16}$	O	16.384 MHz clock (CMOS): This output is used for ST-BUS operation with a 16.384MHz clock.
27	C6	O	Clock 6.312 MHz (CMOS Output). This output is used for DS2 applications.
29	HOLDOVER	O	Holdover (CMOS Output). This output goes to a logic high whenever the digital PLL goes into holdover mode.
30	GTi	I	Guard Time (Schmitt input): The signal at this pin is used by the device's state machine in both Manual and Automatic modes to effect the TIE function and the state changes between Primary Holdover and Primary Normal, and Primary Holdover and Secondary Normal. Refer to Tables 6 and 7. The signal at this pin is clocked in by the rising edge of F8.
32	GTo	O	Guard Time (CMOS): The LOS1 input is clocked in by the rising edge of F8, then buffered and sent to GTo when in Automatic Mode. This pin is typically used to drive GTi input through an RC circuit.
33	LOS2	I	Secondary Reference Loss (TTL): This pin is normally connected to an external source that applies high logic level whenever the secondary reference signal is lost or invalid. The existing level at this pin is clocked in by the rising edge of F8. This pin is internally pulled down to GND.
34	LOS1	I	Primary Reference Loss (TTL): A high level is applied on this pin when the Primary reference signal is lost or invalid. Refer to pin description of LOS2. This pin is internally pulled down to GND.
35	TDO	O	Test Serial Data Out (TTL Output). JTAG serial data is output on this pin on the falling edge of TCK. This pin is held in high impedance state when JTAG scan is not enable.
36	MS2	I	Mode/Control Select 2 (TTL): Along with MS1, determines the operating modes (Manual or Automatic) and operating states when in Maunal mode (Normal, Holdover or Free-Run).
37	MS1	I	Mode/Control Select 1 (TTL): Refer to pin description of MS2. This Pin is internally pilled down to GND.
38	RSEL	I	Reference Source Select (TTL): In Manual mode, low logic level at this pin selects the Primary Reference as the input reference signal and a high level selects the Secondary. For Automatic mode, this pin must always be maintained at low logic level. This pin is internally pulled down to GND.
39	TEST	I	Test (TTL Input). This input is normally tied low. When pulled high, it enables internal test modes. This pin is internally pulled down to GND.
40	FS2	I	Frequency Select 2 (TTL): Together with FS1, selects one of the three DPLL feedback frequencies to match the desired Input Reference Frequency (8 kHz, 1.544 MHz or 2.048 MHz).
41	FS1	I	Frequency Select 1 (TTL): Refer to the pin description of FS2.
42	TDI	I	Test Serial Data In (TTL Input). JTAG serial test instructions and data are shifted in on this pin. This pin is internally pulled up to V_{CC} .
43	\overline{RST}	I	Reset (Schmitt): \overline{RST} Resets the device when at low logic level. Reset is needed whenever the operating mode is changed, or the reference signal frequency is switched or when power-up; so as to ensure proper operation of the device. Following Reset, the output clocks and frame signals are phase-aligned with the input reference source.
44	TMS	I	Test Mode Select (TTL Input). JTAG signal that controls the state transitions of the TAP controller. This pin is internally pulled up to V_{CC} .

Functional Description

Overall Operation

The PT7A4409/4409L is a multitruunk synchronizer that provides the clock and frame signals for T1 and E1 primary rate digital transmission links, and STS-3/OC3 links.

It basically consists of the Clock Generator, Mode/State Control Machine, Time Interval Error (TIE) Corrector, Digital Phase-Locked Loop (DPLL), Analog Phase- Locked Loop (APLL), Input Impairment Monitor and Output Interface Circuit.

The DPLL circuit provides synchronization of the output signals with any given input reference signal, and the TIE circuit ensures phase continuity whenever the input reference signal source is changed.

Referring to the block diagram on Page 3, the detailed functions of the PT7A4409/4409L are described as follows.

Master Clock

The PT7A4409/4409L uses either an external clock source or an external crystal and a few discrete components with its internal oscillator as the master clock.

Reference Select MUX

The PT7A4409/4409L accepts two independent reference signals, the primary reference and secondary reference. Either one of them is selected by the Reference Select MUX circuit and sent to the TIE circuit. The selection is decided according to the availability and quality of the reference signals, the mode operation, and State. Refer to Tables 3, 6 and 7.

Feedback Frequency Select MUX

The feedback frequency is selected by FS1 and FS2 (as shown in Table 3) to match the particular incoming reference frequency (1.544MHz, 2.048MHz or 8kHz). A reset (\overline{RST}) must be performed after every frequency select input change.

Table 3. Feedback Frequency Selection

FS2	FS1	Input Frequency
0	0	Reserved
0	1	8kHz
1	0	1.544MHz
1	1	2.048MHz

Time Interval Error (TIE) Corrector

The purpose of the TIE corrector is to allow the phase of the output signals to be constant while switching between two mutually incoherent reference signal input sources. Whenever a new input reference signal is selected, the TIE corrector measures the phase difference between it and the feedback signal and aligns them using a variable delay circuit. Thus, the TIE Corrector output a virtual reference input signal for the DPLL that has the same phase as it had for the previous reference signal input source. Thus, the PT7A4409/4409L provides a totally seamless (*glitch-free*) transition from one reference signal to another. The TIE Corrector diagram is shown in Figure 3.

Figure 3. TIE Corrector

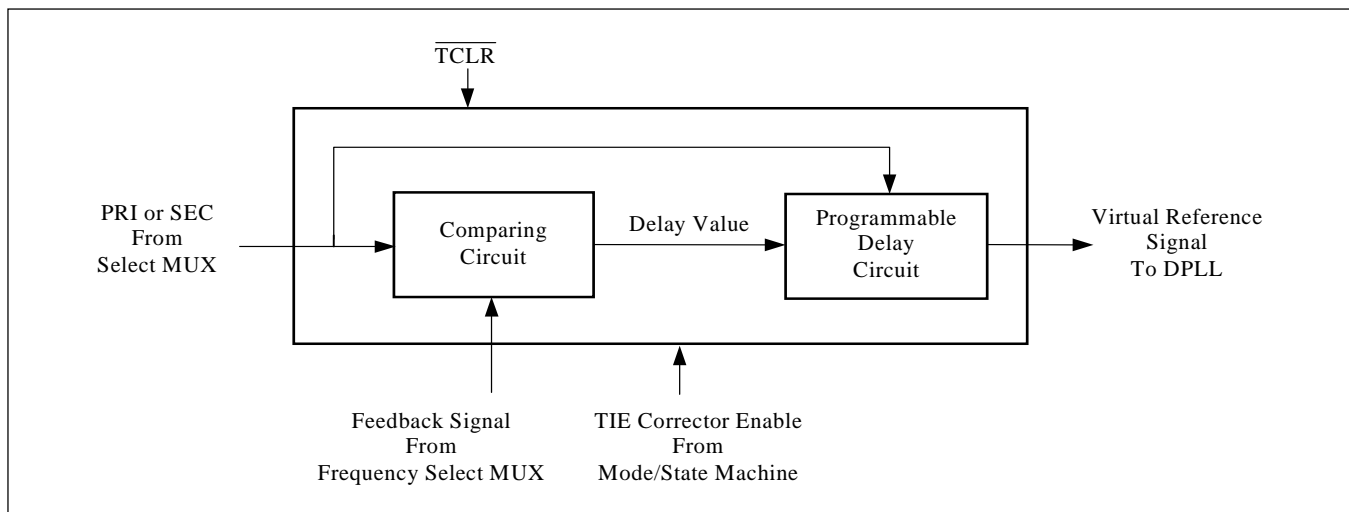

Whenever there is a change in the input reference source, such as a switch from the primary reference signal (PRI) to secondary reference signal (SEC), the typical result is a step change in phase of the DPLL input signal that causes an unacceptable step change in the DPLL input signal phase. The TIE Corrector circuit is used to eliminate the step change in the DPLL input signal phase, thus maintaining continuity of phase at the DPLL output.

Referring to Figure 3, the selected reference signal (e.g. SEC) feeds the Comparing Circuit where it is compared with the feedback signal from the output circuit. Whenever there is a step change in the reference input signal's phase, the Comparing Circuit will generate a Delay Value for the Programmable Delay Circuit. The Delay Circuit then delays the input reference signal by the Delay Value, thus providing the DPLL with a Virtual Reference Signal having no phase discontinuity.

The DPLL phase detects and tracks the Virtual Reference Signal. As the Virtual Reference Signal exhibits no discontinuity of phase, there is no phase transient in the DPLL output signal. This is the Normal operation of the device.

During the input reference signals source switching process, a holdover state will occur before the DPLL begins to track the Virtual Reference Signal. When the input reference is switched to the new source, the State Machine initiates Holdover State, during which the DPLL does not use the Virtual Reference Signal. Instead, it uses stored information to produce a clock signal that is compared in the Comparing Circuit with the Feedback Signal. This compared result is sent to the Programmable Delay Circuit which in turn delivers to the DPLL input a new Virtual Reference Signal whose phase is aligned with that of the previous input reference signal. The State Machine then terminates Holdover State and return the device to Normal state.

As the Programmable Delay Circuit maintains the phase of the Virtual Reference Signal while the TIE Corrector is enabled, there will in general be a time delay between the chip output signals and the selected input reference signal after switching to a new input reference source (e.g. from PRI to SEC). Each time a new reference source is selected, there will in general be a new time delay. The value of this delay represents the accumulation of the phase errors measured and corrected for during the various reference source switching events.

The Programmable Delay Circuit can be zeroed through the TCLR pin (low level, min. duration 300ns), realigning the output signals with the present input reference signal. The speed of realignments is limited by the Limiter in the DPLL to 5ns per 125µs. Convergence is in the direction of least phase travel.

Digital Phase-Locked Loop (DPLL)

The DPLL consists of the Phase Detector, Limiter, Loop Filter, Digitally Controlled Oscillators (DCO1 and DCO2) and Control Circuit. See Figure 4 for the block diagram of DPLL.

The Virtual Reference Signal from TIE is sent to Phase Detector for comparison with the Feedback Signal from the Feedback Frequency Select MUX. An error signal corresponding to their instantaneous phase difference is produced and sent to the Limiter.

The Limiter amplifies this error signal to ensure the DPLL responds to all input transient conditions with a maximum output phase slope of 5ns per 125µs. This performance easily meets the maximum phase slope of 7.6ns per 125µs or 81ns per 1.326ms specified by AT&T TR62411.

The Loop Filter is a 1.9Hz low pass filter for all three reference frequency selections: 8kHz, 1.544MHz and 2.048MHz. The filter ensures that the jitter transfer requirements in ETS 300-011 and AT&T TR62411 are met.

Figure 4. Block Diagram of DPLL

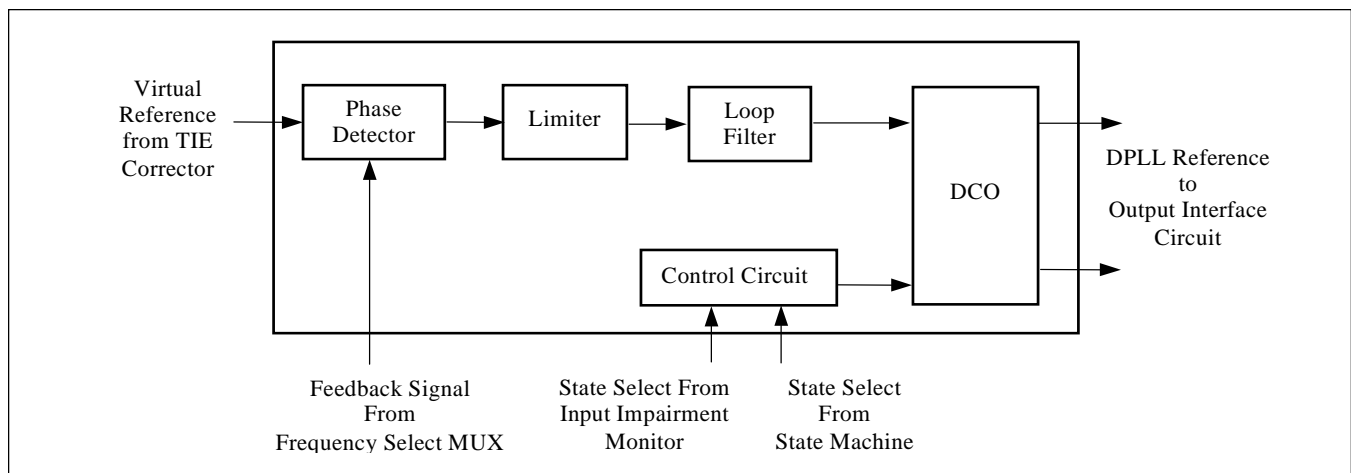

The Control Circuit uses signals from the State Machine and Input Impairment Monitor to control the operating states of the DPLL. Three states are available, Normal, Holdover and Free-Run.

The Error Signal, after limited and filtered, is sent to two Digitally Controlled Oscillators. Based on the processed error value, the DCO will generate the corresponding digital output signals for the Tapped Delay Line in the Output Interface Circuit to produce 12.352MHz, 12.624MHz, 19.44MHz and 16.384MHz signals. The DCO synchronization method depends upon the PT7A4409/4409L operating state, as follows:

In Normal state, the DCO generates four output signals which are frequency and phase locked to the selected input reference signal.

In Holdover state, the DCO generates four output signals whose frequencies are equal to what they were for a 30ms period shortly before the end of the last Normal State.

In Free-Run state, the DCO is free running with an accuracy equal to that of the OSCi 20MHz source.

Output Interface Circuit

The Output Interface Circuit consists of the Tapped Delay Lines and E1/T1 Dividers as shown in Figure 5.

Signals from the DCO are sent to Tapped Delay Lines to generate four clock signals, 16.384MHz, 12.624MHz, 19.44MHz and 12.352MHz, which are divided in the T1 and E1 Dividers respectively to provide needed clock and frame signals.

The T1 Divider uses the 12.352MHz signal to generate two clock signals, C1.5 and $\overline{C3}$. They have a nominal 50% duty cycle.

The DS2 Divider uses 12.624MHz signal to generate clock signal C6.

Clock signal C19 is generated from 19.44MHz by tapped Delay Line.

The E1 Divider uses the 16.384MHz signal to generate four clock signals and three frame signals, i.e., C2, C4, C8, $\overline{C16}$, F0, F8 and F16. The frame signals are generated directly from the C16 signal.

The C2, $\overline{C4}$, C8 and $\overline{C16}$ signals have nominal 50% duty cycle.

All the frame and clock outputs are locked to each other for all operating states. They have limited driving capability and should be buffered when driving high capacitance (e.g., 30pF) loads.

Figure 5. Block Diagram of Output Interface Circuit

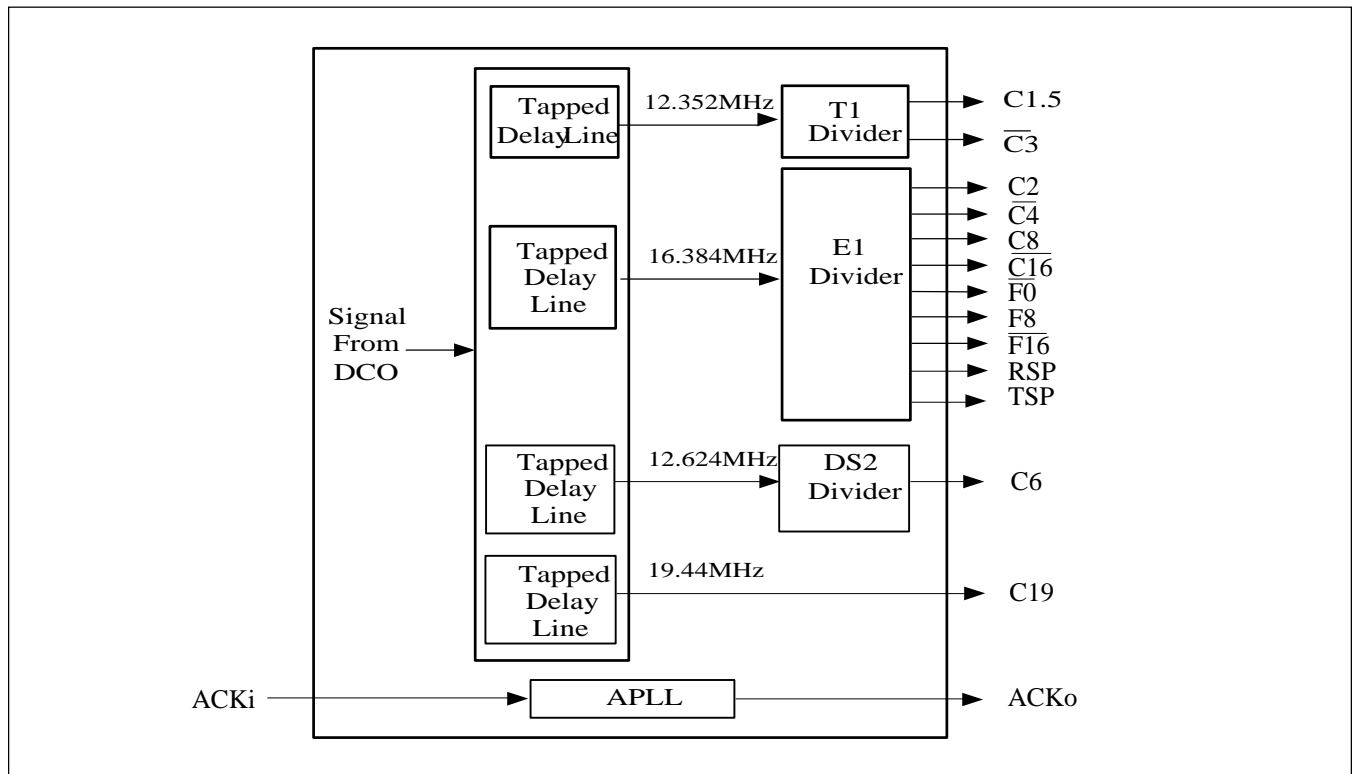

Mode/State Control Machine

The Mode/State Control Machine determines whether the PT7A4409/4409L operates in Automatic or Manual mode, and whether it is in the Normal, Holdover or Free-Run state. In Automatic Mode, the PT7A4409/4409L selects one of three states, Normal, Holdover or Free-Run State. The sequence is determined by LOS1, LOS2 and GTi signals. In Manual Mode, a single state of operation is selected, in accordance with the MS1, MS2, GTi and RSEL signals.

All mode and state changes are synchronous with the rising edge of F8. See the Modes and States of Operation section for complete details.

Guard Time Circuit

The Guard Time Circuit sends control signal (GTi) to Mode/State Control Machine for control of Modes and States. It has two functions:

- enabling/disabling the TIE Corrector (Manual and Automatic) (Refer to Table 6 and 7);
- selecting which mode change takes place (Automatic only).

Under Automatic Mode and in Primary Normal State, two state changes are possible (not counting Auto-Holdover). They are:

- Primary Normal to Primary Holdover, and
- Primary Normal to Secondary Normal.

The level at the GTi pin determines which state occurs. When

- GTi=0, Primary Normal to Primary Holdover,
- GTi=1, Primary Normal to Secondary Normal.

Input Impairment Monitor

This circuit monitors the input signals to the DPLL and automatically enables the Holdover State (Auto-Holdover) when the incoming signal is completely lost, or if its frequency is outside the auto-holdover capture range (either a small or large amount). When the incoming signal returns to normal, the DPLL will be returned to Normal State.

Figure 6. Block Diagram of Mode/State Control Machine

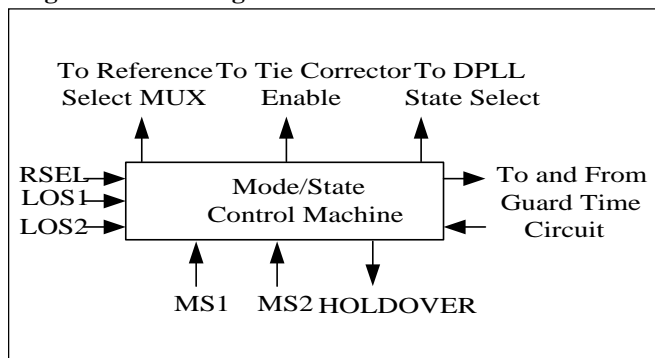

The Auto-Holdover circuit does not use TIE correction. Therefore, the phase delay between the input and output after switching back to Normal State is preserved (is the same as just prior to the switch to Auto-Holdover).

APLL

The analog PLL is intended to be used to achieve a 50% Duty cycle output clock. Connecting C19 to AVKi will generate a phase locked 19.44 MHz ACK0 output with a nominal 50% duty cycle and a maximum peak-to-peak unfiltered jitter of 0.174 U.I. the analog PLL has an intrinsic jitter level separate pins are provided to power (AVDD, AGND) the analog PLL.

Modes and States of Operation

The PT7A4409/4409L operates either in Manual mode or Automatic mode. Each mode has three possible operating states, Normal, Holdover or Free-Run.

Shown in Table 4 and Table 5 are the mode and state selection instructions, using pins MS1, MS2, and RSEL.

Table 4. Input Reference Selection

Modes	RSEL	Input Reference
Manual	0	PRI
	1	SEC
Auto	0	Mode/State Machine Control
	1	Reserved

Table 5. Operation Modes and States

MS2	MS1	Modes	States
0	0	Manual	Normal
0	1	Manual	Holdover
1	0	Manual	Freerun
1	1	Auto	Mode/State Machine Control

Manual Mode

The Manual Operation Mode is used when either very simple control is required, or when complex control is required which is not accommodated by Automatic Mode. For example, Manual Mode can be used in a system requiring only Normal State and only one input stimulus (RSEL). Complex control is used for systems requiring states of operation and more input stimuli. In such cases, external circuitry, typically a microcontroller, is needed.

In Manual Mode, one of the three states is selected by MS2 and MS1. The active reference input is selected by the RSEL pin. See Table 4 and Table 5. For the state change situation, refer to Table 6 and Figure 7.

Automatic Mode

Automatic Mode is used in systems requiring neither very simple nor very complex control, which can be realized by the PT7A4409/4409L in accordance with the State Change Diagram shown in Figure 8.

Automatic Mode is also selected by MS2 and MS1 (set 1,1). In this Mode, the PT7A4409/4409L will operate in three states alternatively. The changes of states will follow a sequence automatically under control of LOS1, LOS2 and GTi. See Table 7 and Figure 8 for the state change sequence.

Normal State

In Normal State, the PT7A4409/4409L output signals are synchronized with one of two input reference inputs.

In this state, the input reference signal is used, with or without TIE correction, as reference for the DPLL phase detector.

Holdover State

In Holdover State, the output signals of PT7A4409/4409L are not synchronized with the external input reference signal. Instead, they are generated by using the information stored 30ms to 60ms before when the device operated in Normal State.

When in Normal Mode, a numerical value corresponding to the output reference frequency is stored alternately in two memory locations every 30ms. When the device is switched into Holdover state, the value in memory from (between 30ms and 60ms) is used to set the output frequency of the device.

Generally, the amount of phase drift while in Holdover is negligible because the Holdover State is very accurate. Two factors affect the accuracy of Holdover State. One is drift on the Master Clock while in Holdover State. The change in OSCi accuracy while in Holdover, other than absolute Master Clock (OSCi) accuracy, will affect the holdover accuracy. The other factor is large jitter on the reference input prior (30 to 60ms) to the mode switch.

The Holdover State is generally used for short durations, under control of GTi signal, when the synchronization to the input reference is temporarily disturbed.

Free-Run State

Typically the Free-Run State is used when a master clock is required or immediately following system power-up before network synchronization is achieved.

In Free-Run State, the outputs of the PT7A4409/4409L are uncorrelated with the input reference signal and the stored information of output reference. Instead, these output signals are based solely on the master clock frequency (OSCi). The accuracy of the output clock is equal to the accuracy of the master clock (OSCi).

Table 6. Manual Operation Mode

Input Control				State				
MS2	MS1	RSEL	GTi	Free-Run S0	Normal (PRI) S1	Normal (SEC) S2	Holdover (PRI) S1H	Holdover (SEC) S2H
0	0	0	0	S1	-	S1 TIE	S1	S1 TIE
0	0	0	1	S1	-	S1 TIE	S1 TIE	S1 TIE
0	0	1	X	S2	S2 TIE	-	S2 TIE	S2 TIE
0	1	0	X	/	S1H	/	-	/
0	1	1	X	/	/	S2H	/	-
1	0	X	X	-	S0	S0	S0	S0

Legend: -: No change

/: Not valid

TIE: State change occurs with TIE Corrector circuit.

Refer to figure 6 for state changes to and from Auto-Holdover state.

Figure 7. Diagram of State Change in Manual Mode

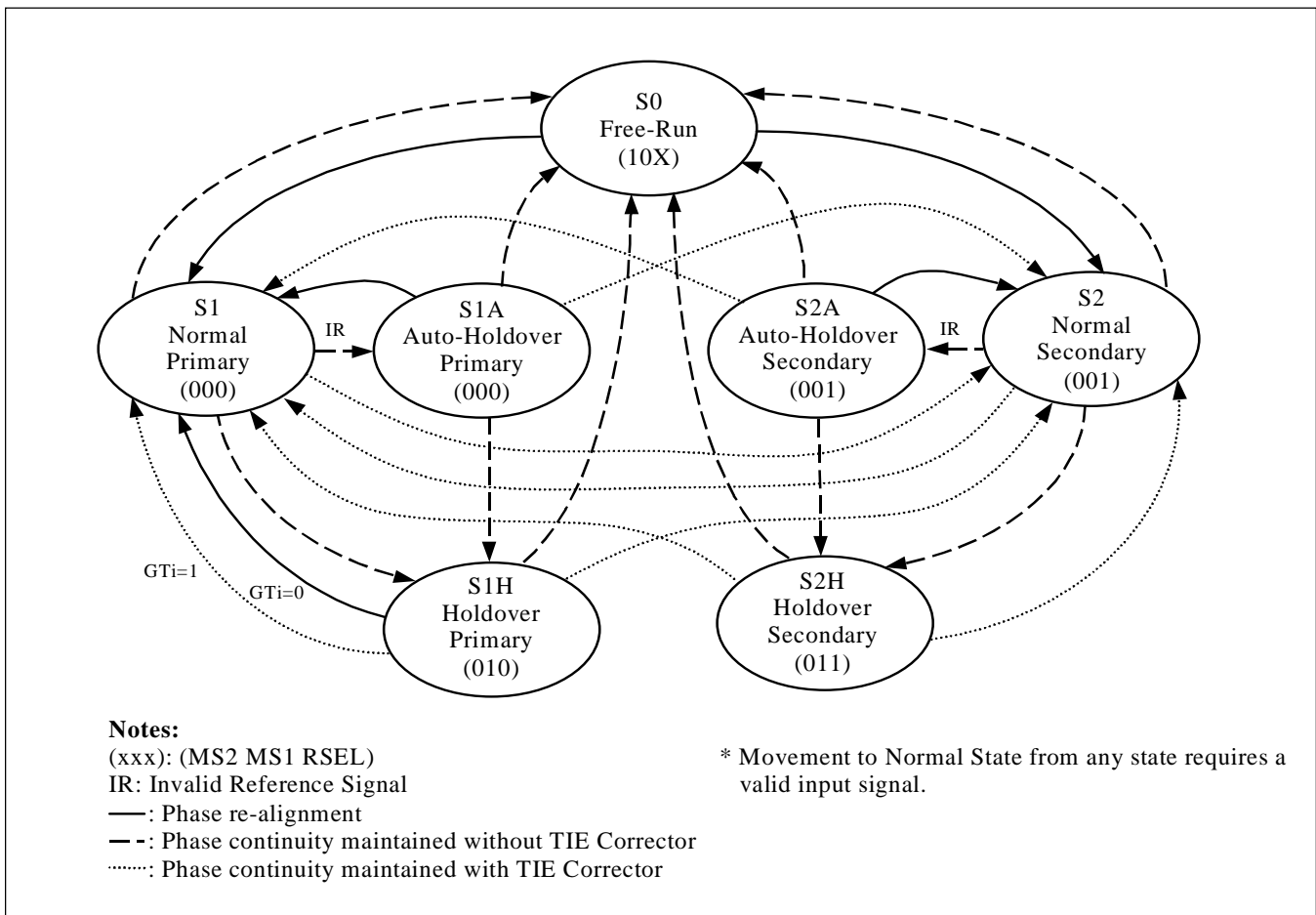
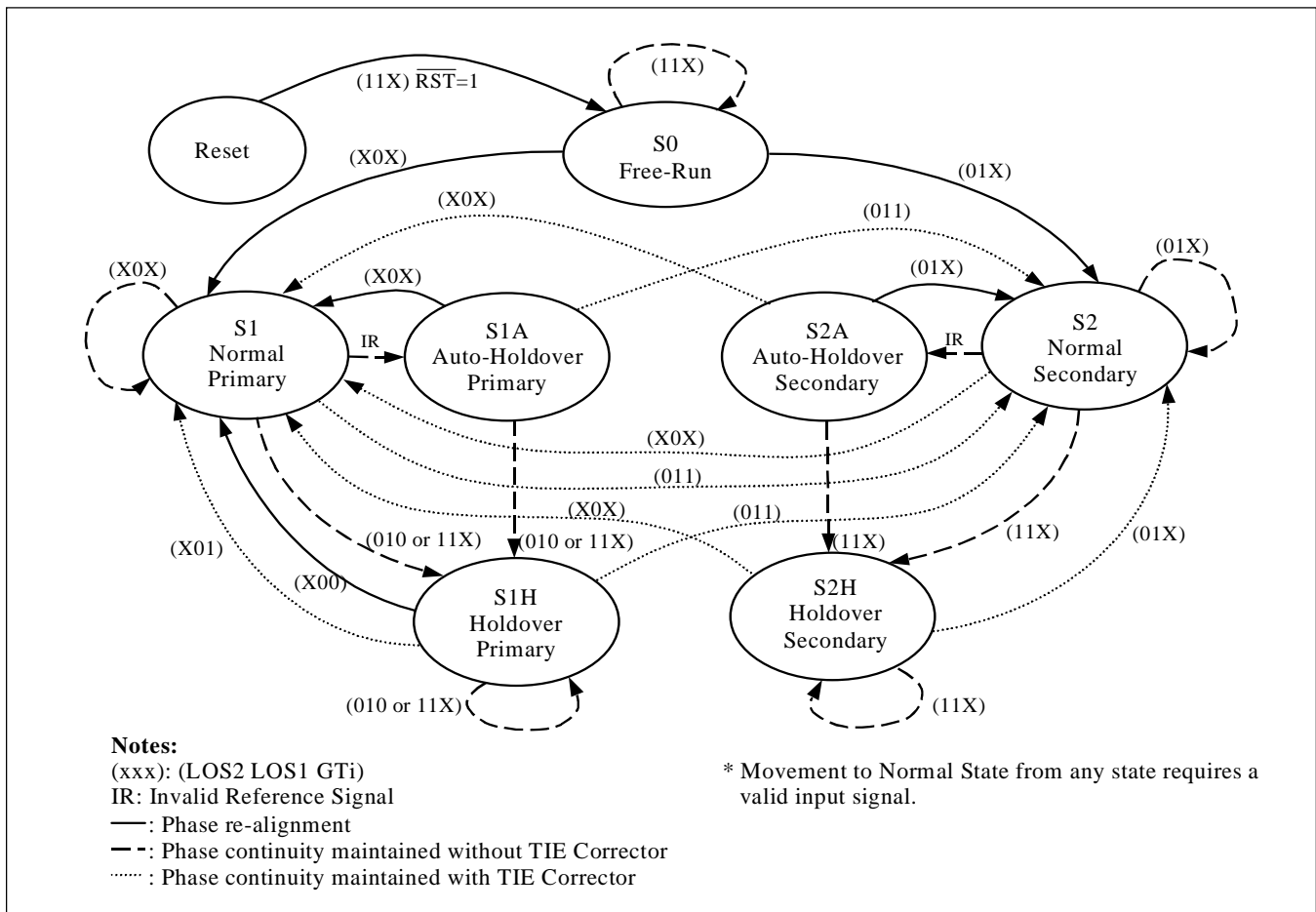

Table 7. Automatic Operation Mode (MS1 MS2=11, RSEL=0)

Input Control				State				
LOS2	LOS1	GTi	RST	Free-Run S0	Normal (PRI) S1	Normal (SEC) S2	Holdover (PRI) S1H	Holdover (SEC) S2H
1	1	X	0 to 1	-	S0	S0	S0	S0
X	0	0	1	S1	-	S1 TIE	S1	S1 TIE
X	0	1	1	S1	-	S1 TIE	S1 TIE	S1 TIE
0	1	0	1	S2	S1H	-	-	S2 TIE
0	1	1	1	S2	S2 TIE	-	S2 TIE	S2 TIE
1	1	X	1	-	S1H	S2H	-	-

Legend: -: No change
 /: Not valid
 TIE: State change occurs with TIE Corrector circuit.
 Refer to figure 7 for state changes to and from Auto-Holdover state.

Figure 8. Diagram of State Change in Automatic Mode



Applications Information

Master Clock

The PT7A4409/4409L uses either an external clock source or an external crystal as the master timing source.

In Free-Run State, the frequency tolerance of the PT7A4409/4409L output clocks are equal to the frequency tolerance of the timing source. In an application, if an accurate Free-Run State is not required, the tolerance of the master timing source may be 100ppm. If required, the tolerance must be no greater than 32ppm.

The capture range of PT7A4409/4409L will also be considered when deciding the accuracy of the master timing source. The sum of the accuracy of the master timing source and the capture range of the PT7A4409/4409L will always equal 230ppm. For example, if the master timing source is 100ppm, the capture range will be 130ppm.

• Clock Oscillator

If using an external clock source, its output pin should be connected directly (not AC coupled) to the OSCi pin of the PT7A4409/4409L and the OSCo pin of PT7A4409/4409L can be left open as shown in Figure 9 or connected as an output pin.

Figure 9. Clock Oscillator Connection

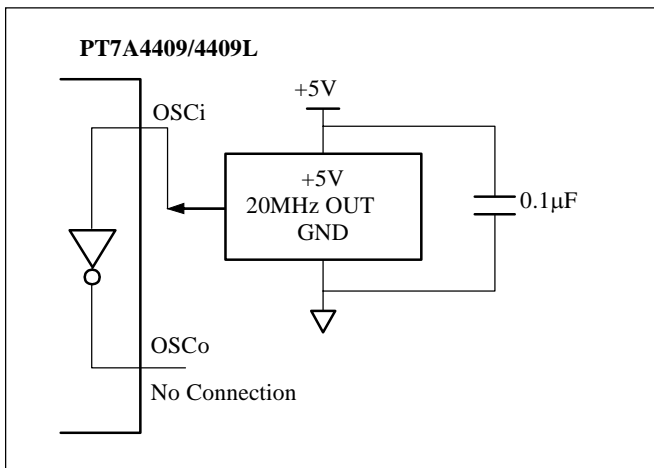

When selecting the clock oscillator, following specifications should be considered. They are

- absolute frequency
- frequency change over temperature
- output rise and fall time
- output level
- duty cycle

Refer to AC Electrical Characteristics.

• Crystal Oscillator

If a crystal oscillator is selected as the master timing source, it should be connected to the PT7A4409/4409L as shown in Figure 10.

Figure 10. Crystal Oscillator Connection

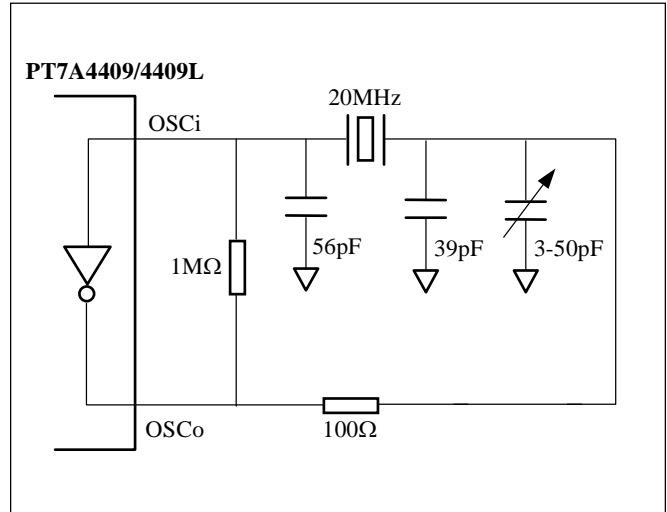

The crystal specification is as follows:

- | | |
|------------------------------|-------------|
| - Frequency: | 20MHz |
| - Tolerance: | as required |
| - Oscillation Mode: | Fundamental |
| - Resonance Mode: | Parallel |
| - Load Capacitance: | 32pF |
| - Maximum Series Resistance: | 35Ω |
| - Approximate Drive Level: | 1mW |

Guard Time Adjustment Circuit

AT&T TR62411 recommends that excessive switching of the timing reference should be minimized. Switching between references should be performed only when the primary signal is degraded.

The Holdover State is used to minimize reference source switching (from PRI to SEC). When the PRI signal is degraded, the PT7A4409/4409L enters Holdover State for a predetermined maximum time (i.e., guard time). If the PRI signal returns to normal before the expiration of the guard time (level at GTi pin is low), the PT7A4409/4409L will return to Normal State with PRI input reference. If the PRI signal is still degraded after expiration of the guard time (level at GTi becomes high), the reference switching (from PRI to SEC) will occur.

A simple way to control the Guard Time is shown in Figure 11. The Guard Time can be calculated as follows:

$$t_{Gd} = RC \times \ln \left(\frac{V_{CC}}{V_{CC} - V_{SIH}} \right) \cong RC \times 0.6$$

* V_{SIH} is the logic high going threshold for the GTi Schmitt Trigger input, see DC Electrical Characteristics.

In cases where fast toggling of the LOS1 input might be expected, an unsymmetrical Guard Time Circuit is recommended as shown in Figure 12. This setting ensures that reference switching does not occur until the entire guard time has expired. The timing diagram is shown in Figure 13.

Figure 11. Symmetrical Guard Time Circuit

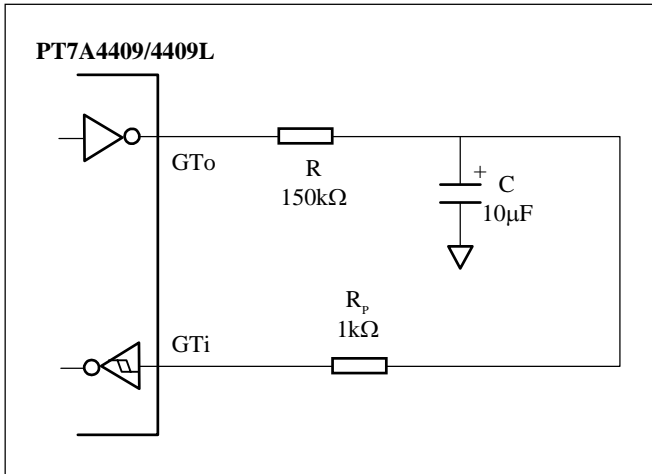

Figure 12. Unsymmetrical Guard Time Circuit

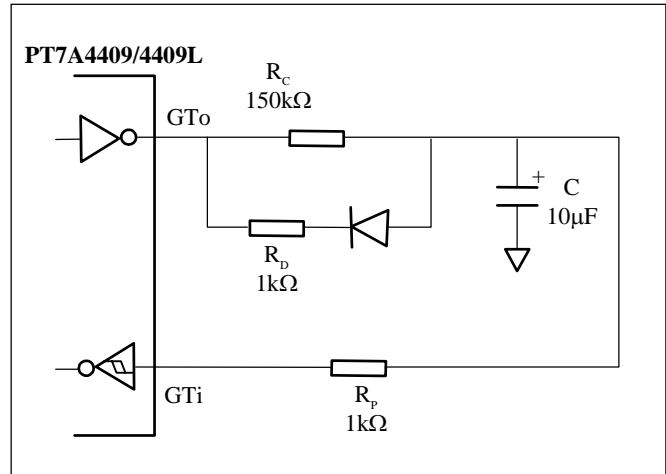
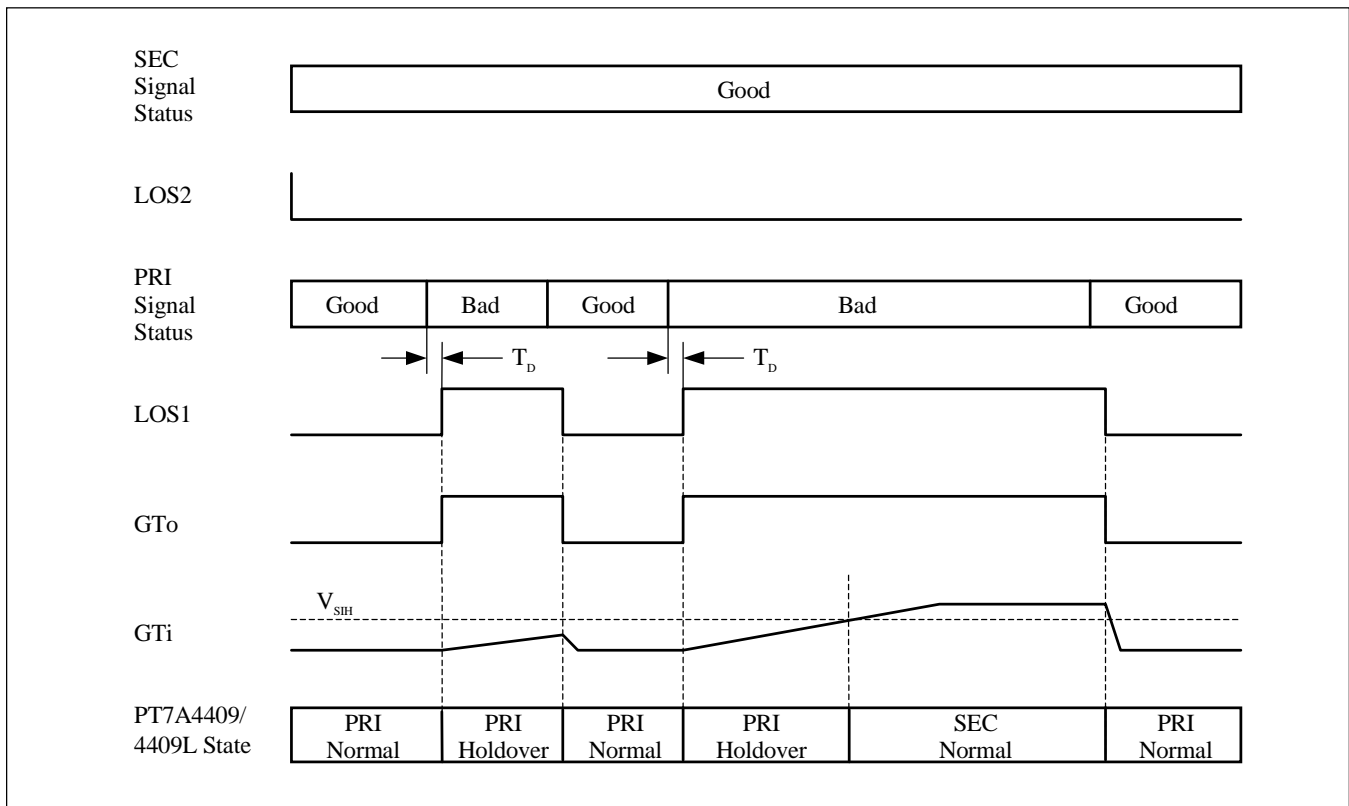

Figure 13. Timing Example of Unsymmetrical Guard Time Circuit in Automatic Mode



Reset Circuit

A simple power up reset circuit with about a 50 μ s reset active (low) time is shown in Figure 14. Resistor R_p is for protection only. The reset low time is not critical but should be greater than 300ns.

Figure 14. Power-up Reset Circuit

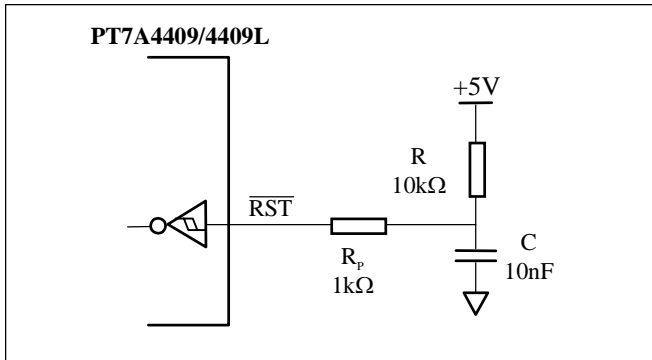

Power Supply Decoupling

The PT7A4409/4409L has two V_{CC} pins and two GND pins. Power decoupling capacitors should be included as shown in Figure 15.

Figure 15. Power Supply Decoupling

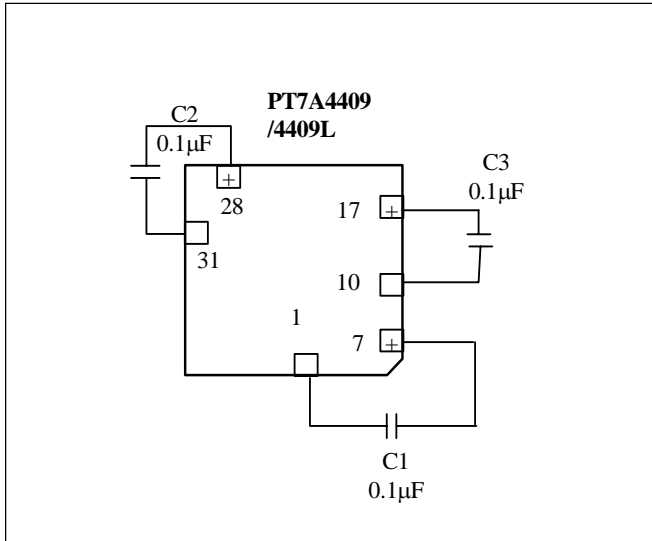

Detailed Specifications

Definitions of Critical Performance Specifications

Intrinsic Jitter: Intrinsic jitter is the jitter produced by the synchronizing circuit. It is measured by applying a reference signal with no jitter to the input of the device, and measuring its output jitter. Intrinsic jitter may also be measured when the device is in a non-synchronizing mode - such as free running or holdover - by measuring the output jitter of the device. Intrinsic jitter is usually measured with various band limiting filters depending on the applicable standards.

Jitter Tolerance: Jitter tolerance is a measure of the ability of a PLL to operate properly (i.e., remain in lock and/or regain lock in the presence of large jitter magnitudes at various jitter frequencies) when jitter is present on its reference. The applicable standard specifies how much jitter to apply to the reference when testing for jitter tolerance.

Jitter Transfer: Jitter transfer or jitter attenuation refers to the magnitude of jitter at the output of a device with respect to a given amount of jitter at the input of the device. Input jitter is applied at various amplitudes and frequencies, and output jitter is measured with various filters depending on the applicable standards.

Its 3 possible input frequencies and 9 outputs give the PT7A4409/4409L 27 possible jitter transfer combinations. However, only three cases of the jitter transfer specifications are given in the AC Electrical Characteristics; as the remaining combinations can be derived from them.

For the PT7A4409/4409L, two internal elements determine the jitter attenuation. They are internal 1.9Hz low pass loop filter and phase slope limiter. The phase slope limiter limits the output phase slope to 5ns/125 μ s. Therefore, if the input signal exceeds this rate, such as for very large amplitude low frequency input jitter, the maximum output phase slope will be limited (i.e., attenuated) to 5ns/125 μ s.

It should be noted that 1UI at 1.544MHz (644ns) is not equal to 1UI at 2.048MHz (488ns). A transfer value using different input and output frequencies must be calculated in common units (e.g., seconds) as shown in the following example.

Example : When the T1 input jitter is 20UI (T1 UI Units) and the T1 to T1 jitter attenuation is 18dB, The T1 and E1 output jitter can be calculated as follows:

$$J_{T1o} = J_{T1i} \times 10 \left(\frac{-A}{20} \right) = 20 \times 10 \left(\frac{-18}{20} \right) = 2.5UI$$

$$J_{E1o} = J_{T1o} \times \left(\frac{|U|T1}{|U|E1} \right) = J_{T1o} \times \left(\frac{644ns}{488ns} \right) = 3.3UI$$

Using the above method, the jitter attenuation can be calculated for all combinations of inputs and outputs based on the three jitter transfer functions provided.

Note that the resulting jitter transfer functions for all combinations of inputs (8kHz, 1.544MHz, 2.048MHz) and outputs (8kHz, 1.544MHz, 2.048MHz, 4.096MHz, 8.192MHz, 16.384MHz, 6.312MHz, 19.44MHz) for a given input signal (jitter frequency and jitter amplitude) are the same.

Since intrinsic jitter is always present, jitter attenuation will appear to be lower for small input jitter signals than for large ones. Consequently, accurate jitter transfer function measurements are usually made with large input jitter signals (e.g., 75% of the specified maximum jitter tolerance).

Frequency Accuracy: Frequency accuracy is defined as the absolute tolerance of an output clock signal when it is not locked to an external reference, but is operating in a free running mode. For the PT7A4409/4409L, the Free-Run accuracy is equal to the Master Clock (OSCi) accuracy.

Holdover Accuracy: Holdover accuracy is defined as the absolute tolerance of an output clock signal, when it is not locked to an external reference signal, but is operating using storage techniques. For the PT7A4409/4409L the storage value is determined while the device is in Normal State and locked to an external reference signal. The absolute Master Clock (OSCi) accuracy of the PT7A4409/4409L does not affect Holdover accuracy, but the change in OSCi accuracy while in Holdover Mode does.

Lock Range: If the PT7A4409/4409L DPLL is already in a state of synchronization (*lock*) with the incoming reference signal, it is able to track this signal to maintain lock as its frequency varies over a certain range, called the Lock Range. The size of Lock Range is related to the range of the Digitally Controlled Oscillators and is equal to 230ppm minus the accuracy of the master clock (OSCi). For example, a 32ppm master clock results in a Lock Range of 198ppm.

Capture Range: The PT7A4409/4409L DPLL is not at present in a state of synchronization (lock) with the incoming reference signal, it is able to initiate (acquire) lock only if the signal's frequency is within a certain range, called the Capture Range. For any PLL, no portion of the Capture Range can fall outside the Lock Range, and, in general, the Capture Range is more narrow than the Lock Range. However, owing to the design of its Phase Detector, the PT7A4409/4409L's Capture Range is equal to its Lock Range.

Phase Slope: Phase slope is measured in seconds per second and is the rate at which a given signal changes phase with respect to an ideal signal of constant frequency. The given signal is typically the output signal. The ideal signal is of constant frequency and is nominally equal to the value of the final output signal or final input signal.

Time Interval Error (TIE): TIE is the time delay between a given timing signal and an ideal timing signal.

Maximum Time Interval Error (MTIE): MTIE is the maximum peak to peak delay between a given timing signal and an ideal timing signal within a particular observation period.

$$MTIE(S) = TIE_{max}(t) - TIE_{min}(t)$$

Phase Continuity: Phase continuity is the phase difference between a given timing signal and an ideal timing signal at the end of a particular observation period. Usually, the given timing signal and the ideal timing signal are of the same frequency. Phase continuity applies to the output of the synchronizer after a signal disturbance due to a reference source switch or a state change. The observation period is usually the time from the disturbance, to just after the synchronizer has settled to a steady state.

For the PT7A4409/4409L, the output signal phase continuity is maintained to within 5ns at the instance (over one frame) of all reference source switches and all state changes. The total phase shift, depending on the switch or type of state change, may accumulate up to 200ns over many frames. The rate of change of the 200ns phase shift is limited to a maximum phase slope of approximately 5ns/125µs. This meets the AT&T TR62411 maximum phase slope requirement of 7.6ns/125µs (81ns/1.326ms).

Absolute Maximum Ratings

Storage Temperature	-65°C to +150°C
Ambient Temperature with Power Applied	-40°C to +85°C
Supply Voltage to Ground Potential (Inputs & V _{CC} Only)	-0.3 to 7.0V
Supply Voltage to Ground Potential (Outputs & D/O Only)	-0.3 to 7.0V
DC Input Voltage	-0.3 to 7.0V
DC Output Current	120mA
Power Dissipation	900mW

Note:
 Stresses greater than those listed under MAXIMUM RATINGS may cause permanent damage to the device. This is a stress rating only and functional operation of the device at these or any other conditions above those indicated in the operational sections of this specification is not implied. Exposure to absolute maximum rating conditions for extended periods may affect reliability.

Recommended Operating Conditions

Table 8. Recommended Operating Conditions

Sym	Description	Test Conditions	Min	Typ	Max	Units
V _{CC}	Supply Voltage for 4409	Over Recommended Operating Conditions	4.5	5.0	5.5	V
	Supply Voltage for 4409L		3.0	3.3	3.6	V
T _A	Operating Temperature		-40	25	85	°C

DC Electrical and Power Supply Characteristics

Table 9. DC Electrical and Power Supply Characteristics

Sym	Description	Device	Test Conditions	Min	Typ	Max	Units
I _{CCQ}	Quiescent Power Supply Current	4409	OSC _i = 0V, Note 2			20	mA
		4409L				10	mA
I _{CC}	Supply Current	4409	OSC _i = Clock, Note 2			60	mA
		4409L				35	mA
		4409	OSC _i = Crystal, Note 2			70	mA
		4409L				40	mA
V _{IH}	TTL HIGH Input Voltage-All pins except OSC _i , $\overline{\text{RST}}$ and GT _i			2.0			V
V _{IL}	TTL LOW Input Voltage-All pins except OSC _i , $\overline{\text{RST}}$ and GT _i					0.8	V
V _{CIH}	CMOS HIGH Input Voltage-OSC _i pin			0.7V _{CC}			V
V _{CIL}	CMOS LOW Input Voltage-OSC _i pin					0.3V _{CC}	V
V _{SIH}	Schmitt HIGH Input Voltage-GT _i , $\overline{\text{RST}}$ pins	4409		3.6			V
		4409L		2.6			V
V _{SIL}	Schmitt LOW Input Voltage-GT _i , $\overline{\text{RST}}$ pins	4409				1.8	V
		4409L				1.1	V
V _{HYS}	Schmitt Hysteresis Voltage-GT _i , $\overline{\text{RST}}$ pins			0.4			V
I _{IL}	Input Leakage Current - Pins: TCK, SEC, PRI, TDI, TMS	4409	V _i = V _{CC} or 0V	-140			μA
		4409L		-100			μA
	4409				140	μA	
	4409L				100	μA	
	Input Leakage Current - other pins			-10		10	μA
V _{OH}	HIGH Output Voltage	4409	I _{OH} = -4mA	2.4			V
		4409L		2.0			V
V _{OL}	LOW Output Voltage		I _{OL} = 4mA			0.8	V

Note:

1. Supply voltages and operating temperature are as per Recommended Operating Conditions.
2. MS2 = V_{CC}, FS1 = V_{CC}, FS2 = GND, other inputs connected to GND.
3. All outputs are unloaded except for V_{OH} and V_{OL} measurement.

AC Electrical Characteristics

Performance

Table 10. Performance

Sym	Description	Test Conditions*	Min	Typ	Max	Units
	Free-Run State Accuracy with OSCi at:	5-8	0		0	ppm
	0ppm		-32		+32	ppm
	32ppm		-100		+100	ppm
	100ppm					
	Holdover State Accuracy with OSCi at:	1, 2, 4, 6-8, 40	-0.05		+0.05	ppm
	0ppm		-0.05		+0.05	ppm
	32ppm		-0.05		+0.05	ppm
	100ppm					
	DPLL Capture Range With OSCi at:	1-3, 6-8	-190		+230	ppm
	0ppm		-158		+198	ppm
	32ppm		-90		+130	ppm
	100ppm					
	APLL Capture Range	43	10		30	MHz
	Phase Lock Time	1-3, 6-14			23	s
	Output Phase Continuity with: Reference Switch	1-3, 6-14			200	ns
	State Switch to Normal	1-2, 4-14			200	ns
	State Switch to Free-Run	1-4, 6-14			200	ns
	State Switch to Holdover	1-3, 6-14			50	ns
	MTIE (Maximum Time Interval Error)	1-14, 27			600	ns
	Output Phase Slope				45	μs/s
	Reference Input for Auto-Holdover with:	1-3, 6, 9-11	<-30k	or	>+30k	ppm
	8kHz		<-30k	or	>+30k	ppm
	1.544MHz		<-30k	or	>+30k	ppm
	2.048MHz	1-3, 8-11	<-30k	or	>+30k	ppm

* Refer to the **Test Conditions** on Page 32 for details.

Voltage Levels for Timing Parameter Measurement

Table 11. Voltage Levels for Timing Parameter Measurement

Sym	Description	Schmitt	TTL	CMOS	Units
V_T	Threshold Voltage	$0.5V_{CC}$	1.5	$0.5V_{CC}$	V
V_{HM}	Rising and Falling Threshold Voltage High	$0.7V_{CC}$	2.0	$0.7V_{CC}$	V
V_{LM}	Rising and Falling Threshold Voltage Low	$0.3V_{CC}$	0.8	$0.3V_{CC}$	V

Figure 16. Voltage Levels for Timing Parameter Measurement

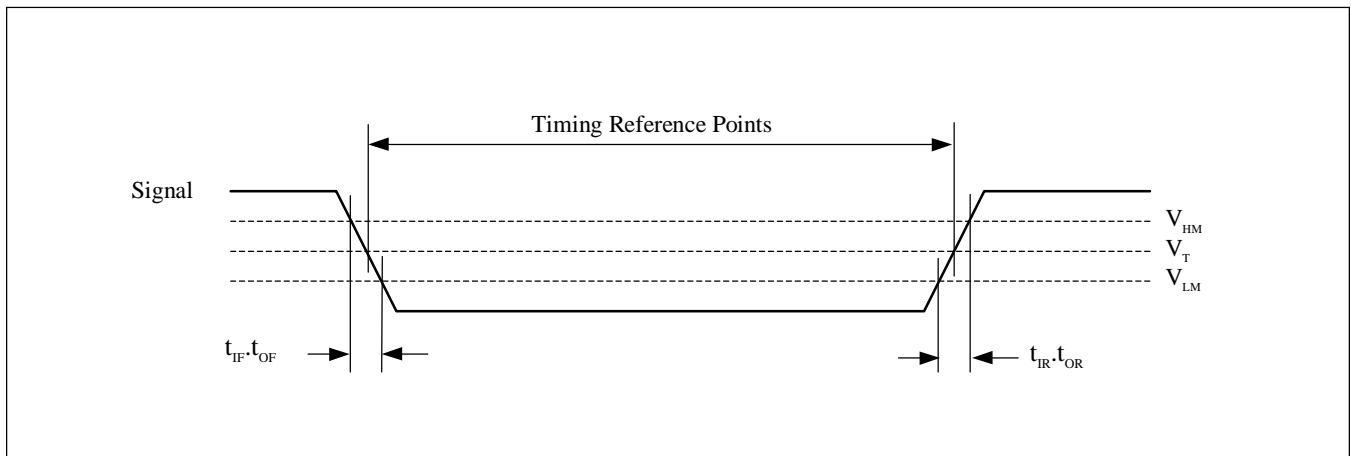

Input and Output Timing

Table 12. Input and Output Timing of 4409

Sym	Description	Test Conditions*	Min	Typ	Max	Units
t_{RW}	Reference Input pulse Width High or Low	1-3, 6-11, 39	100			ns
t_{IRF}	Reference Input Rising or Falling Time				10	ns
t_{R8D}	8kHz Reference Input to F8 Delay	1-3, 6-14, 21, 23, 38	-28		-1	ns
t_{R15D}	1.544kHz Reference Input to F8 Delay		337		363	ns
t_{R2D}	2.048kHz Reference Input to F8 Delay		217		238	ns
t_{F0D}	F8 to $\overline{F0}$ Delay	1-14, 21, 39	110		134	ns
t_{F16D}	F8 to $\overline{F16}$ Delay	1-14, 21	19		44	ns
t_{C15D}	F8 to C1.5 Delay	1-14, 21, 39	-45		-31	ns
t_{C6D}	F8 to C6 Delay		-8		9	ns
t_{C3D}	F8 to $\overline{C3}$ Delay		-46		-31	ns
t_{C2D}	F8 to C2 Delay		-10		5	ns
t_{C4D}	F8 to $\overline{C4}$ Delay		-10		5	ns
t_{C8D}	F8 to C8 Delay		-10		5	ns
t_{C16D}	F8 to $\overline{C16}$ Delay		-10		5	ns
t_{TSPD}	F8 to TSP Delay		-10		10	ns
t_{RSPD}	F8 to RSP Delay		-10		10	ns
t_{C19D}	F8 to C19 Delay		0		52	ns
t_{C15W}	C1.5 Pulse Width High or Low		309		339	ns
t_{C3W}	$\overline{C3}$ Pulse Width High or Low		149		175	ns
t_{C6W}	C6 Pulse Width High or Low		72		86	ns
t_{C2W}	C2 Pulse Width High or Low		230		258	ns
t_{C4W}	$\overline{C4}$ Pulse Width High or Low		111		133	ns
t_{C8W}	C8 Pulse Width High or Low		52		70	ns

* Refer to the **Test Conditions** on Page 32 for details.

Table 13. Input and Output Timing of 4409L

Sym	Description	Test Conditions*	Min	Typ	Max	Units
t _{RW}	Reference Input pulse Width High or Low	1-3, 6-11, 39	100			ns
t _{IRF}	Reference Input Rising or Falling Time				10	ns
t _{R8D}	8kHz Reference Input to F8 Delay	1-3, 6-14, 21, 23, 38	-21		6	ns
t _{R15D}	1.544kHz Reference Input to F8 Delay		345		371	ns
t _{R2D}	2.048kHz Reference Input to F8 Delay		232		248	ns
t _{F0D}	F8 to $\overline{F0}$ Delay	1-14, 21, 39	112		138	ns
t _{F16D}	F8 to $\overline{F16}$ Delay	1-14, 21	19		44	ns
t _{C15D}	F8 to C1.5 Delay	1-14, 21, 39	-47		-31	ns
t _{C6D} ¹⁾	F8 to C6 Delay		-9		9	ns
t _{C3D}	F8 to $\overline{C3}$ Delay		-49		-32	ns
t _{C2D}	F8 to C2 Delay		-11		4	ns
t _{C4D}	F8 to $\overline{C4}$ Delay		-11		4	ns
t _{C8D}	F8 to C8 Delay		-11		4	ns
t _{C16D}	F8 to $\overline{C16}$ Delay		-11		4	ns
t _{TSPD} ¹⁾	F8 to TSP Delay		-10		10	ns
t _{RSPD} ¹⁾	F8 to RSP Delay		-10		10	ns
t _{C19D} ¹⁾	F8 to C19 Delay		0		52	ns
t _{C15W}	C1.5 Pulse Width High or Low		309		339	ns
t _{C3W}	$\overline{C3}$ Pulse Width High or Low		149		175	ns
t _{C6W} ¹⁾	C6 Pulse Width High or Low		72		86	ns
t _{C2W}	C2 Pulse Width High or Low		230		258	ns
t _{C4W}	$\overline{C4}$ Pulse Width High or Low		111		133	ns
t _{C8W}	C8 Pulse Width High or Low	52		70	ns	

* Refer to the **Test Conditions** on Page 32 for details.

Table 14. Input and Output Timing (Continued)

Sym	Description	Test Conditions*	Min	Typ	Max	Units
t_{C16WL}	$\overline{C16}$ Pulse Width Low	1-14, 21	26		37	ns
t_{TSPW}	TSP Pulse Width High		478		494	ns
t_{RSPW}	RSP Pulse Width High		478		495	ns
t_{C19W}	C19 Pulse Width High or Low		16		36	ns
t_{F0WL}	$\overline{F0}$ Pulse Width Low	1-14, 21, 39	230		258	ns
t_{F8WH}	F8 Pulse Width High		111		133	ns
t_{F16WL}	$\overline{F16}$ Pulse Width Low		52		70	ns
t_{ORF}	Output Clock and Frame Pulse Rising or Falling Time				9	ns
t_S	Input Controls Setup Time		100			ns
t_H	Input Controls Hold Time		100			ns

* Refer to the **Test Conditions** on Page 32 for details.

Figure 17. Input to Output Timing (Normal State, after \overline{TCLR} or \overline{RST})

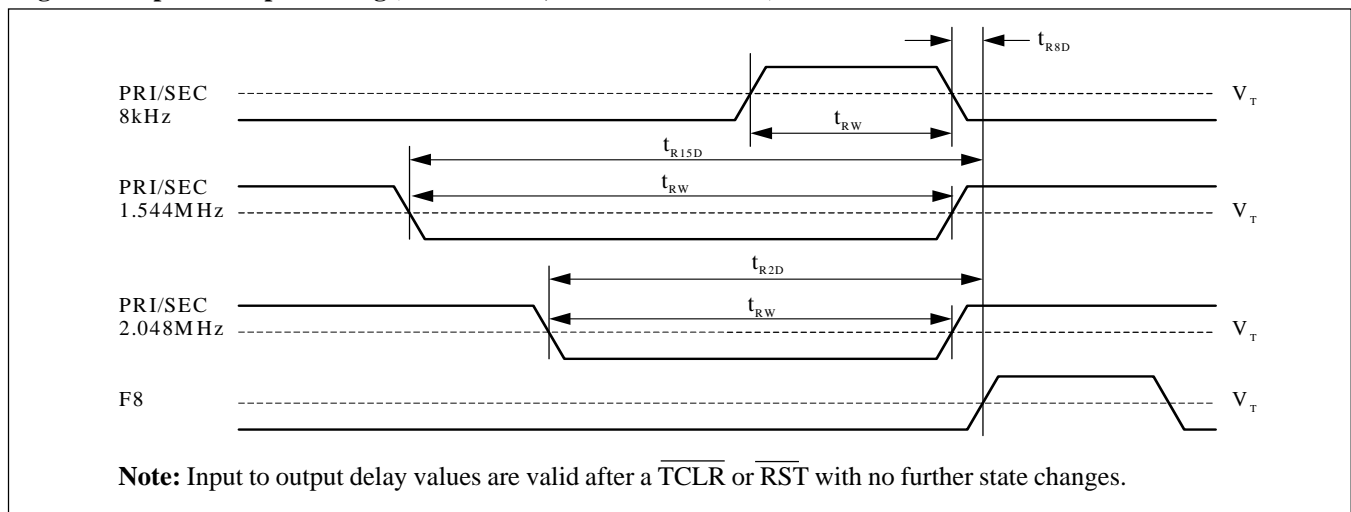

Figure 18. Output Timing

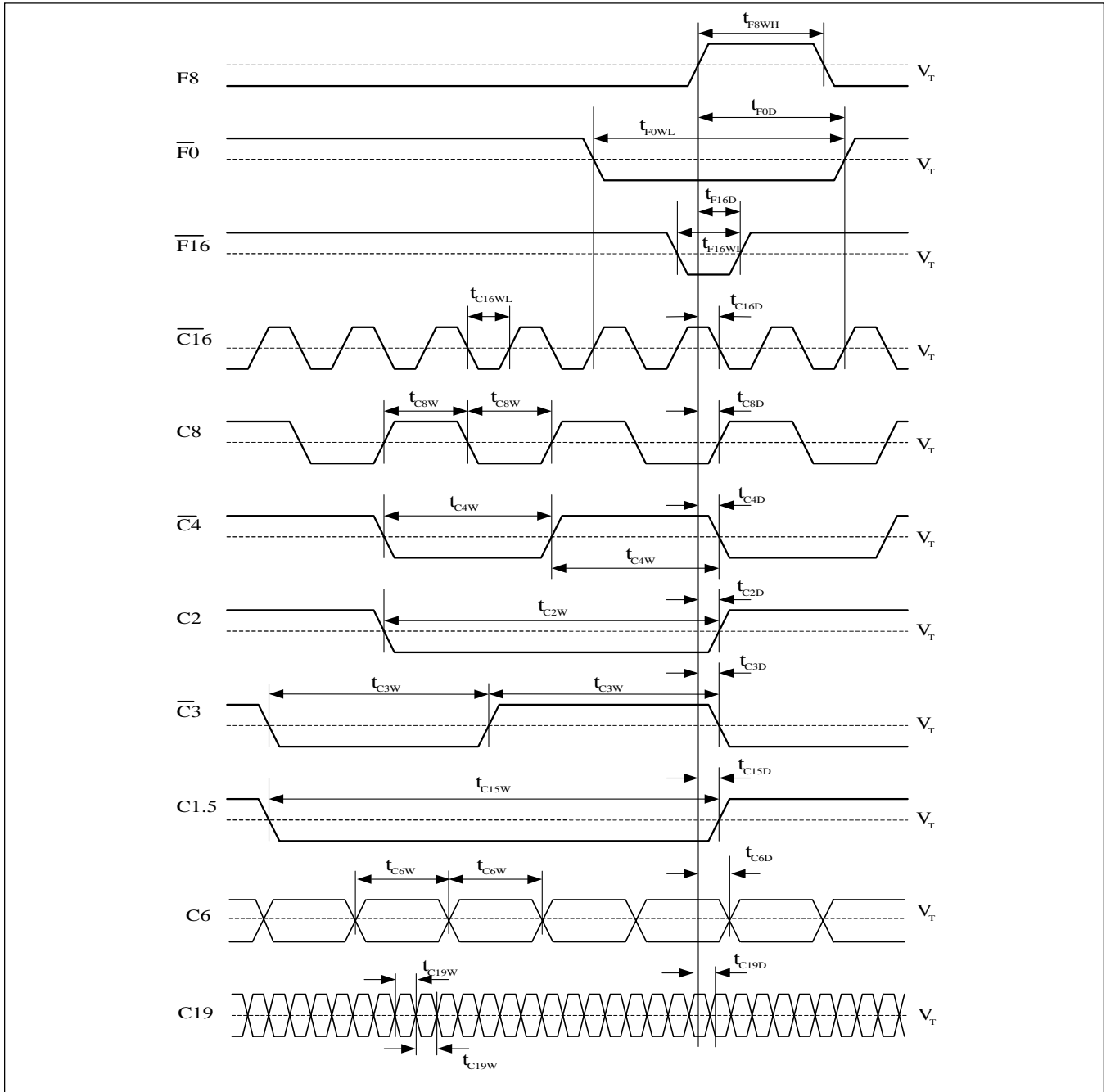

Figure 19. Output Timing

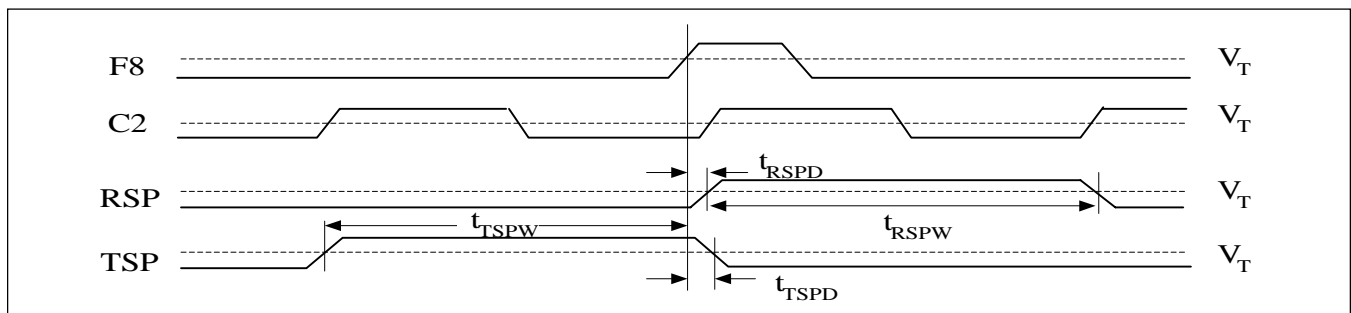
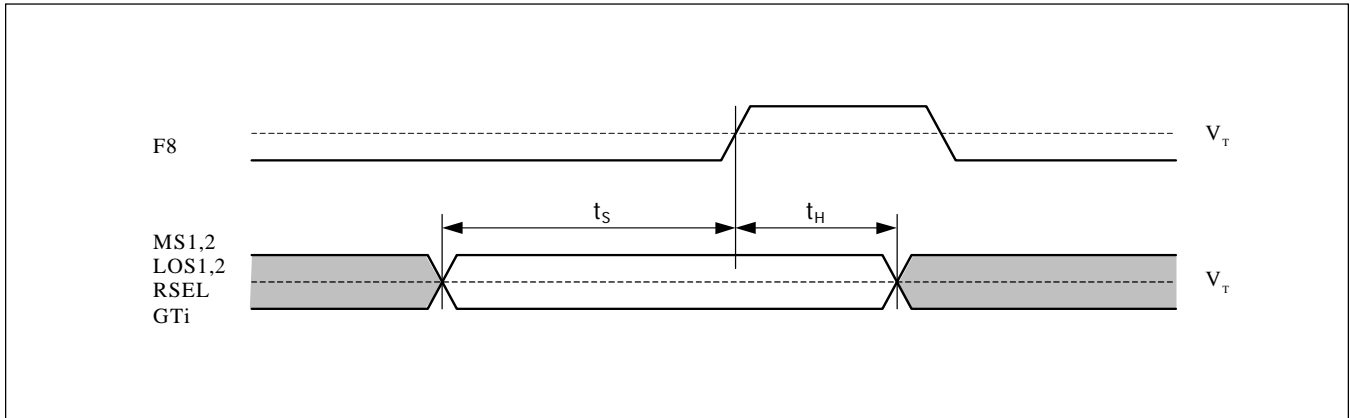

Figure 20. Setup and Hold Timing of Input Controls



Intrinsic Jitter Unfiltered

Table 15. Intrinsic Jitter Unfiltered

Sym	Description	Test Conditions*	Min	Typ	Max	Units
	Intrinsic Jitter at F8 (8kHz)	1-14, 21-24, 28			0.0002	UIpp
	Intrinsic Jitter at $\overline{F0}$ (8kHz)				0.0002	UIpp
	Intrinsic Jitter at $\overline{F16}$ (8kHz)				0.0002	UIpp
	Intrinsic Jitter at C1.5 (1.544MHz)	1-14, 21-24, 29			0.030	UIpp
	Intrinsic Jitter at C2 (2.048MHz)	1-14, 21-24, 30			0.040	UIpp
	Intrinsic Jitter at $\overline{C3}$ (3.088MHz)	1-14, 21-24, 31			0.060	UIpp
	Intrinsic Jitter at $\overline{C4}$ (4.096MHz)	1-14, 21-24, 32			0.080	UIpp
	Intrinsic Jitter at C6 (6.312MHz)	1-14, 21-24, 41			0.120	UIpp
	Intrinsic Jitter at C8 (8.192MHz)	1-14, 21-24, 33			0.160	UIpp
	Intrinsic Jitter at $\overline{C16}$ (16.384MHz)	1-14, 21-24, 34			0.320	UIpp
	Intrinsic Jitter at C19 (19.44MHz)	1-14, 21-24, 42			0.230	UIpp
	Intrinsic Jitter at TSP (8kHz)	1-14, 21-24, 28			0.0002	UIpp
	Intrinsic Jitter at RSP (8kHz)	1-14, 21-24, 28			0.0002	UIpp

* Refer to the **Test Conditions** on Page 32 for details.

C1.5 (1.544MHz) Intrinsic Jitter Filtered

Table 16. C1.5 (1.544MHz) Intrinsic Jitter Filtered

Sym	Description	Test Conditions*	Min	Typ	Max	Units
	Intrinsic Jitter (4Hz to 100kHz Filter)	1-14, 21-24, 29			0.015	UIpp
	Intrinsic Jitter (10Hz to 40kHz Filter)				0.010	UIpp
	Intrinsic Jitter (8kHz to 40kHz Filter)				0.010	UIpp
	Intrinsic Jitter (10Hz to 8kHz Filter)				0.005	UIpp

* Refer to the **Test Conditions** on Page 32 for details.

C2 (2.048MHz) Intrinsic Jitter Filtered

Table 17. C2 (2.048MHz) Intrinsic Jitter Filtered

Sym	Description	Test Conditions*	Min	Typ	Max	Units
	Intrinsic Jitter (4Hz to 100kHz Filter)	1-14, 21-24, 30			0.015	UIpp
	Intrinsic Jitter (10Hz to 40kHz Filter)				0.010	UIpp
	Intrinsic Jitter (8kHz to 40kHz Filter)				0.010	UIpp
	Intrinsic Jitter (10Hz to 8kHz Filter)				0.005	UIpp

* Refer to the **Test Conditions** on Page 32 for details.

8kHz Input to 8kHz Output Jitter Transfer

Table 18. 8kHz Input to 8kHz Output Jitter Transfer

Sym	Description	Test Conditions*	Min	Typ	Max	Units
	Jitter Attenuation for 1Hz with 0.01UIpp Input	1-3, 6, 9-14, 21, 22, 24, 28, 35	0		6	dB
	Jitter Attenuation for 1Hz with 0.54UIpp Input		6		16	dB
	Jitter Attenuation for 10Hz with 0.10UIpp Input		12		22	dB
	Jitter Attenuation for 60Hz with 0.10UIpp Input		28		38	dB
	Jitter Attenuation for 300Hz with 0.10UIpp Input		42			dB
	Jitter Attenuation for 3600Hz with 0.005UIpp Input		45			dB

* Refer to the **Test Conditions** on Page 32 for details.

1.544MHz Input to 1.544MHz Output Jitter Transfer

Table 19. 1.544MHz Input to 1.544MHz Output Jitter Transfer

Sym	Description	Test Conditions*	Min	Typ	Max	Units
	Jitter Attenuation for 1Hz with 20UIpp Input	1-3, 7, 9-14, 21, 22, 24, 29, 35	0		6	dB
	Jitter Attenuation for 1Hz with 104UIpp Input		6		16	dB
	Jitter Attenuation for 10Hz with 20UIpp Input		12		22	dB
	Jitter Attenuation for 60Hz with 20UIpp Input		28		38	dB
	Jitter Attenuation for 300Hz with 20UIpp Input		42			dB
	Jitter Attenuation for 10kHz with 0.3UIpp Input		45			dB
	Jitter Attenuation for 100kHz with 0.3UIpp Input		45			dB

* Refer to the **Test Conditions** on Page 32 for details.

2.048MHz Input to 2.048MHz Output Jitter Transfer

Table 20. 2.048MHz Input to 2.048MHz Output Jitter Transfer

Sym	Description	Test Conditions*	Min	Typ	Max	Units
	Jitter at Output for 1Hz 3.00UIpp Input	1-3,8,9-14,21,22,24,30,35			2.9	UIpp
		1-3,8,9-14,21,22,24,30,36			0.09	UIpp
	Jitter at Output for 3Hz 2.33UIpp Input	1-3,8,9-14,21,22,24,30,35			1.3	UIpp
		1-3,8,9-14,21,22,24,30,36			0.10	UIpp
	Jitter at Output for 5Hz 2.07UIpp Input	1-3,8,9-14,21,22,24,30,35			0.80	UIpp
		1-3,8,9-14,21,22,24,30,36			0.10	UIpp
	Jitter at Output for 10Hz 1.76UIpp Input	1-3,8,9-14,21,22,24,30,35			0.40	UIpp
		1-3,8,9-14,21,22,24,30,36			0.10	UIpp
	Jitter at Output for 100Hz 1.50UIpp Input	1-3,8,9-14,21,22,24,30,35			0.06	UIpp
		1-3,8,9-14,21,22,24,30,36			0.05	UIpp
	Jitter at Output for 2400Hz 1.50UIpp Input	1-3,8,9-14,21,22,24,30,35			0.04	UIpp
		1-3,8,9-14,21,22,24,30,36			0.03	UIpp
	Jitter at Output for 100kHz 0.20UIpp Input	1-3,8,9-14,21,22,24,30,35			0.04	UIpp
		1-3,8,9-14,21,22,24,30,36			0.02	UIpp

* Refer to the **Test Conditions** on Page 32 for details.

8kHz Input Jitter Tolerance

Table 21. 8kHz Input Jitter Tolerance

Sym	Description	Test Conditions*	Min	Typ	Max	Units
	Jitter Tolerance for 1Hz Input	1-3,6,9-14,21,22,24-26,28	0.80			UIpp
	Jitter Tolerance for 5Hz Input		0.70			UIpp
	Jitter Tolerance for 20Hz Input		0.60			UIpp
	Jitter Tolerance for 300Hz Input		0.20			UIpp
	Jitter Tolerance for 400Hz Input		0.15			UIpp
	Jitter Tolerance for 700Hz Input		0.08			UIpp
	Jitter Tolerance for 2400Hz Input		0.02			UIpp
	Jitter Tolerance for 3600Hz Input		0.01			UIpp

* Refer to the **Test Conditions** on Page 32 for details.

1.544MHz Input Jitter Tolerance

Table 22. 1.544MHz Input Jitter Tolerance

Sym	Description	Test Conditions*	Min	Typ	Max	Units
	Jitter Tolerance for 1Hz Input	1-3,7,9-14,21,22,24-26,29	150			UIpp
	Jitter Tolerance for 5Hz Input		140			UIpp
	Jitter Tolerance for 20Hz Input		130			UIpp
	Jitter Tolerance for 300Hz Input		35			UIpp
	Jitter Tolerance for 400Hz Input		25			UIpp
	Jitter Tolerance for 700Hz Input		15			UIpp
	Jitter Tolerance for 2400Hz Input		4			UIpp
	Jitter Tolerance for 10kHz Input		1			UIpp
	Jitter Tolerance for 100kHz Input		0.5			UIpp

* Refer to the **Test Conditions** on Page 32 for details.

2.048MHz Input Jitter Tolerance

Table 23. 2.048MHz Input Jitter Tolerance

Sym	Description	Test Conditions*	Min	Typ	Max	Units
	Jitter Tolerance for 1Hz Input	1-3,8,9-14,21,22,24-26,30	150			UIpp
	Jitter Tolerance for 5Hz Input		140			UIpp
	Jitter Tolerance for 20Hz Input		130			UIpp
	Jitter Tolerance for 300Hz Input		50			UIpp
	Jitter Tolerance for 400Hz Input		40			UIpp
	Jitter Tolerance for 700Hz Input		20			UIpp
	Jitter Tolerance for 2400Hz Input		5			UIpp
	Jitter Tolerance for 10kHz Input		1			UIpp
	Jitter Tolerance for 100kHz Input		1			UIpp

* Refer to the **Test Conditions** on Page 32 for details.

OSCi 20MHz Master Clock Input

Table 24. OSCi 20MHz Master Clock Input

Sym	Description	Test Conditions*	Min	Typ	Max	Units
	Tolerance	15, 18	0		0	ppm
		16, 19	-32		+32	ppm
		17, 20	-100		+100	ppm
	Duty Cycle		40		60	%
	Rising Time				10	ns
	Falling Time				10	ns

* Refer to the **Test Conditions** on Page 32 for details.

Notes:

1. Voltages are with respect to ground (GND) unless otherwise stated.
2. Supply voltage and operation temperature are as per Recommended Operating Conditions.
3. Timing parameters are as per AC Electrical Characteristics - Voltage Levels for Timing Parameter Measurement.

Test Conditions:

1. PRI reference input selected.
2. SEC reference input selected.
3. Normal State selected.
4. Holdover State selected.
5. Free-Run State selected.
6. 8kHz frequency source selected.
7. 1.544MHz frequency source selected.
8. 2.048MHz frequency source selected.
9. Master clock input OSCi at 20MHz ± 0 ppm.
10. Master clock input OSCi at 20MHz ± 32 ppm.
11. Master clock input OSCi at 20MHz ± 100 ppm.
12. Selected reference input at ± 0 ppm.
13. Selected reference input at ± 32 ppm.
14. Selected reference input at ± 100 ppm.
15. For Free-Run State of ± 0 ppm.
16. For Free-Run State of ± 32 ppm.
17. For Free-Run State of ± 100 ppm.
18. For capture range of ± 230 ppm.
19. For capture range of ± 198 ppm.
20. For capture range of ± 130 ppm.
21. 25pF capacitive load.
22. OSCi Master Clock Jitter is less than 2ns p-p, or 0.04UI p-p where 1UI p-p = 1/20MHz.
23. Jitter on reference input is less than 7ns p-p.
24. Applied jitter is sinusoidal.
25. Minimum applied input jitter magnitude to regain synchronization.
26. Loss of synchronization is obtained at slightly higher input jitter amplitudes.
27. Within 10ms of the state, reference or input change.
28. 1UIpp = 125 μ s for 8kHz signals.
29. 1UIpp = 648ns for 1.544MHz signals.
30. 1UIpp = 488ns for 2.048MHz signals.
31. 1UIpp = 324ns for 3.088MHz signals.
32. 1UIpp = 244ns for 4.096MHz signals.
33. 1UIpp = 122ns for 8.192MHz signals.
34. 1UIpp = 61ns for 16.384MHz signals.
35. No filter.
36. 40Hz to 100kHz bandpass filter.
37. With respect to reference input signal frequency.
38. After a \overline{RST} or \overline{TCLR} .
39. Master clock duty cycle 40% to 60%.
40. Prior to Holdover State, device was in Normal State and phase locked.
41. 1UIpp = 162ns for 6.312MHz signals.
42. 1UIpp = 51ns for 19.44MHz signals.

Mechanical Specifications

Figure 21. 44-pin PLCC

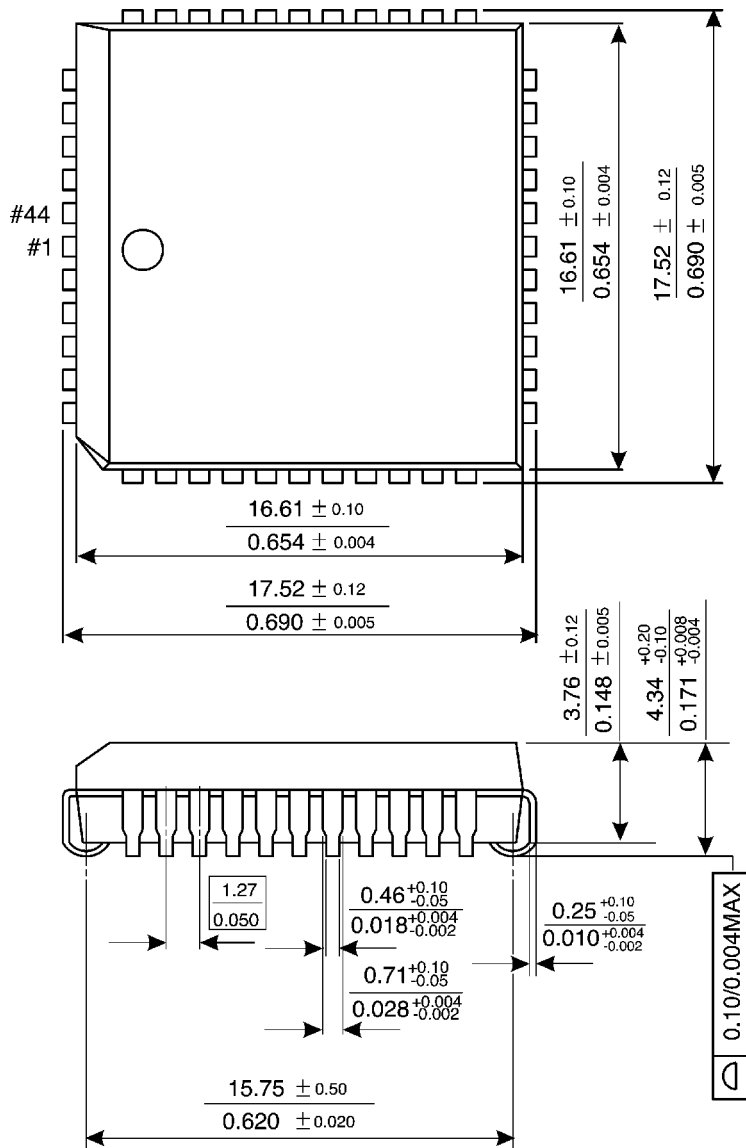

Dimensions in Millimeters/Inches

Note

Pericom Technology Inc.

Email: support@pti.com.cn Web-Site: www.pti.com.cn, www.pti-ic.com

China: No. 20 Building, 3/F, 481 Guiping Road, Shanghai, 200233, China
Tel: (86)-21-6485 0576 Fax: (86)-21-6485 2181

Asia Pacific: Unit 1517, 15/F, Chevalier Commercial Centre, 8 Wang Hoi Rd, Kowloon Bay, Hongkong
Tel: (852)-2243 3660 Fax: (852)- 2243 3667

U.S.A.: 2380 Bering Drive, San Jose, California 95131, USA
Tel: (1)-408-435 0800 Fax: (1)-408-435 1100

Pericom Technology Incorporation reserves the right to make changes to its products or specifications at any time, without notice, in order to improve design or performance and to supply the best possible product. Pericom Technology does not assume any responsibility for use of any circuitry described other than the circuitry embodied in Pericom Technology product. The company makes no representations that circuitry described herein is free from patent infringement or other rights, of Pericom Technology Incorporation.