



## DUAL PRECISION CMOS VOLTAGE COMPARATOR WITH OPEN DRAIN DRIVER

### GENERAL DESCRIPTION

The ALD2301A/ALD2301B/ALD2301/ALD2301C is a monolithic high performance dual voltage comparator built with advanced silicon gate CMOS technology. It features very high typical input impedance of  $10^{12}\Omega$ ; low input bias current of 10pA; fast response time of 300ns; very low power dissipation of 55 $\mu$ A per comparator; and single +5V or dual  $\pm$ 5V power supply operation.

The input voltage range includes ground, making this comparator ideal for low level signal detection with high source impedance. The outputs are open-drain configuration, allowing maximum application flexibility, such as wired-OR connection. The outputs can be connected to a higher external voltage than V+.

The ALD2301A/ALD2301B/ALD2301/ALD2301C is ideal for a great variety of voltage comparator applications, especially low level signal detection circuits requiring low standby power, yet retaining high output current capability as needed.

### FEATURES

- Fanout of 30 LS TTL loads
- Low supply current of 110 $\mu$ A typical
- Functional equivalent to LM193 industry standard comparators
- Extremely low input bias currents -- 10pA typical
- Virtually eliminates source impedance effects
- Low operating supply voltage of 3V to 12V
- Single +5V and dual supply  $\pm$ 5V operation
- High speed for both large signal and low level signals -- 300ns typical for TTL inputs
- CMOS, NMOS and TTL compatible
- Wired-OR open drain outputs
- High output sinking current -- 60mA typical
- Low supply current spikes

### ORDERING INFORMATION

Operating Temperature Range *		
-55°C to +125°C	0°C to +70°C	0°C to +70°C
8-Pin CERDIP Package	8-Pin Small Outline Package (SOIC)	8-Pin Plastic Dip Package
ALD 2301A DA	ALD2301A SA	ALD2301A PA
ALD 2301B DA	ALD 2301B SA	ALD2301B PA
ALD 2301 DA	ALD 2301 SA	ALD2301 PA
ALD 2301C DA	ALD 2301C SA	ALD2301C PA

\* Contact factory for industrial temperature range

### APPLICATIONS

- High source impedance voltage comparison circuits
- Dual limit window comparator
- Power supply voltage monitor
- Photo-detector sensor circuit
- Relay or LED driver
- Oscillators
- Battery operated instruments
- Remote signal detection

### PIN CONFIGURATION

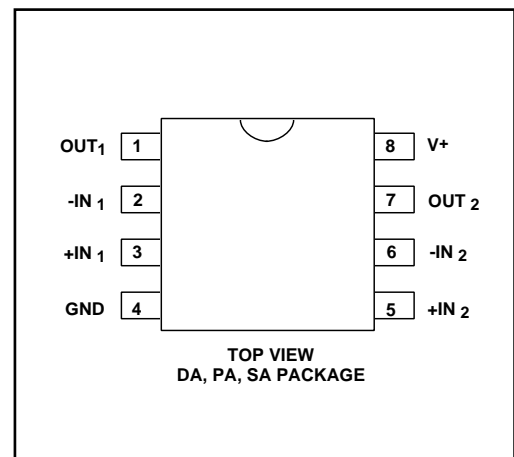

### BLOCK DIAGRAM

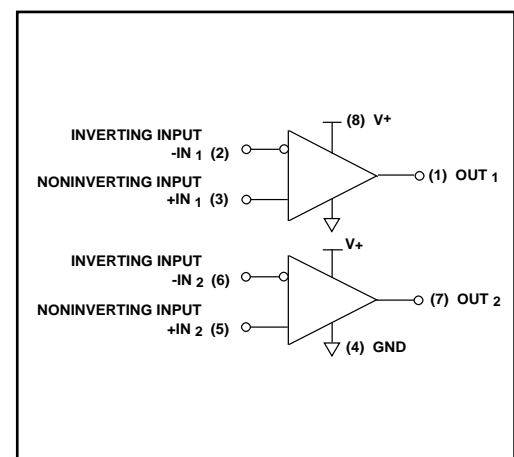

## ABSOLUTE MAXIMUM RATINGS

Supply voltage,  $V^+$  \_\_\_\_\_ 13.2V  
 Differential input voltage range \_\_\_\_\_ -0.3V to  $V^+ + 0.3V$   
 Power dissipation \_\_\_\_\_ 600 mW  
 Operating temperature range PA, SA package \_\_\_\_\_  $0^\circ\text{C}$  to  $+70^\circ\text{C}$   
 DA package \_\_\_\_\_  $-55^\circ\text{C}$  to  $+125^\circ\text{C}$   
 Storage temperature range \_\_\_\_\_  $-65^\circ\text{C}$  to  $+150^\circ\text{C}$   
 Lead temperature, 10 seconds \_\_\_\_\_  $+260^\circ\text{C}$

## OPERATING ELECTRICAL CHARACTERISTICS

$T_A = 25^\circ\text{C}$   $V^+ = +5V$  unless otherwise specified

Parameter	Symbol	2301			2301A			2301B			2301C			Unit	Test Conditions
		Min	Typ	Max	Min	Typ	Max	Min	Typ	Max	Min	Typ	Max		
Voltage Supply	$V^+$	3		12	3		12	3		12	3		12	V	
Supply Current	$I_S$		110	180		110	180		110	180		110	180	$\mu\text{A}$	$R_{LOAD} = \infty$
Voltage Gain	$A_{VD}$	50	150		50	150		50	150		50	150		V/mV	$R_{LOAD} \geq 15K\Omega$
Input Offset Voltage	$V_{OS}$			10			2			5			20	mV	$R_{LOAD} \geq 1.5K\Omega$
Input Offset Current <sup>1</sup>	$I_{OS}$		10	200		10	200		10	200		10	400	pA	
Input Bias Current <sup>1</sup>	$I_B$		10	200		10	200		10	200		10	400	pA	
Common Mode Input Voltage Range <sup>2</sup>	$V_{ICR}$	-0.3		$V^+ - 1.5$	-0.3		$V^+ - 1.5$	-0.3		$V^+ - 1.5$	-0.3		$V^+ - 1.5$	V	
Low Level Output Voltage	$V_{OL}$		0.15	0.4		0.15	0.4		0.15	0.4		0.15	0.4	V	$I_{SINK} = 12\text{mA}$ $V_{INPUT} = 1V$ Differential
Low Level Output Current	$I_{OL}$	24	60		24	60		24	60		24	60		mA	$V_{OL} = 1.0 V$
High Level Leakage Current	$I_{OH}$		.01	20		.01	20		.01	20		.01	20	nA	$V_{OH} = 5.0 V$
Response Time <sup>2</sup>	$t_{RP}$		650			650			650			650		ns	$R_L = 5.1K\Omega$ $C_L = 15\text{pF}$ 100mV Input Step/5mV Overdrive
			300			300			300			300		ns	$R_L = 5.1K\Omega$ $C_L = 15\text{pF}$ TTL - Level Input Step

Notes : <sup>1</sup> Consists of junction leakage currents.  
<sup>2</sup> Sample tested parameters.

# TYPICAL PERFORMANCE CHARACTERISTICS

### SATURATION VOLTAGE vs. TEMPERATURE

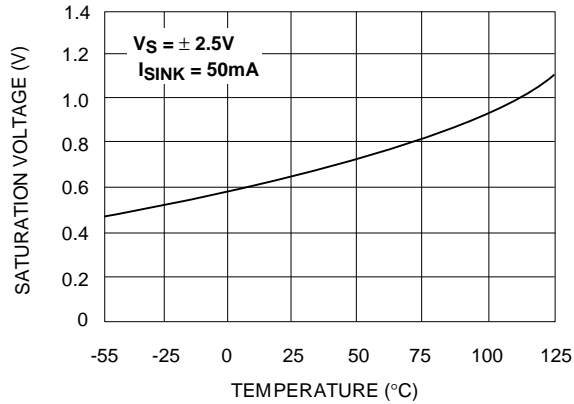

### TRANSFER FUNCTION

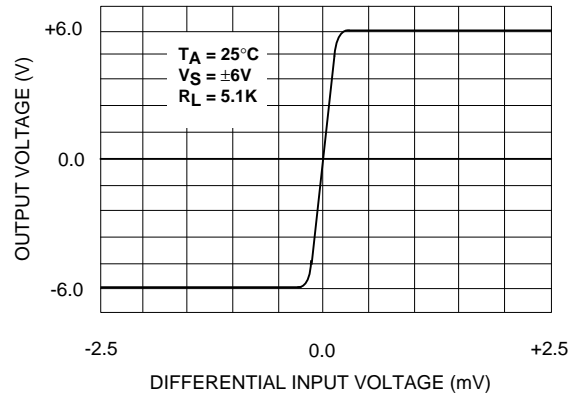

### COMMON - MODE VOLTAGE REFERRED TO SUPPLY VOLTAGE

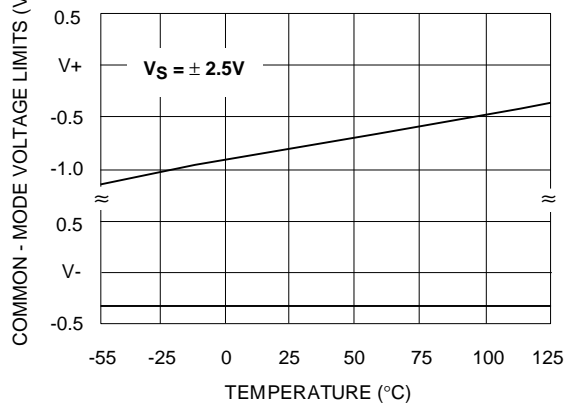

### RESPONSE TIME FOR VARIOUS INPUT OVERDRIVES

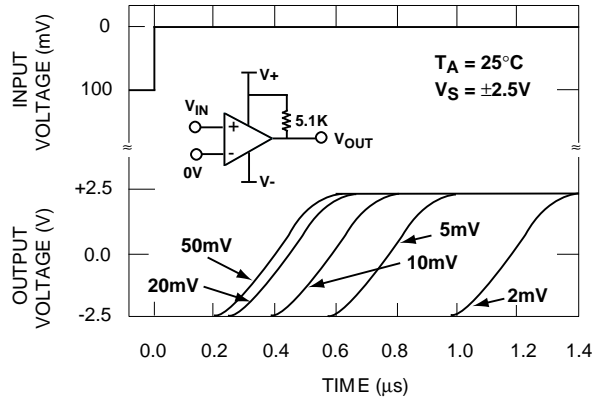

### SATURATION VOLTAGE vs. SINK CURRENT

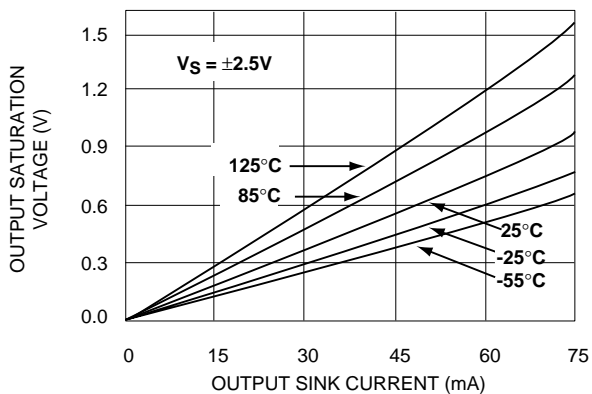

### RESPONSE TIME FOR VARIOUS INPUT OVERDRIVES

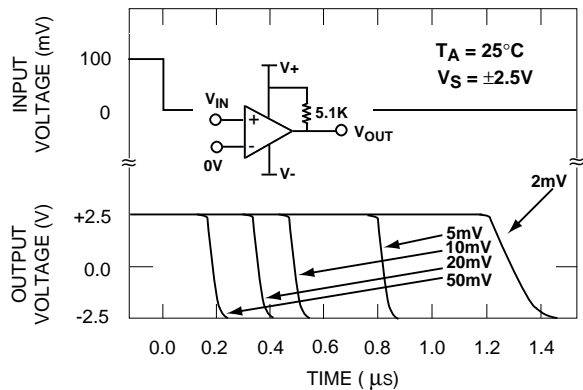

## TYPICAL PERFORMANCE CHARACTERISTICS

**TOTAL SUPPLY CURRENT vs. TOTAL SUPPLY VOLTAGE**

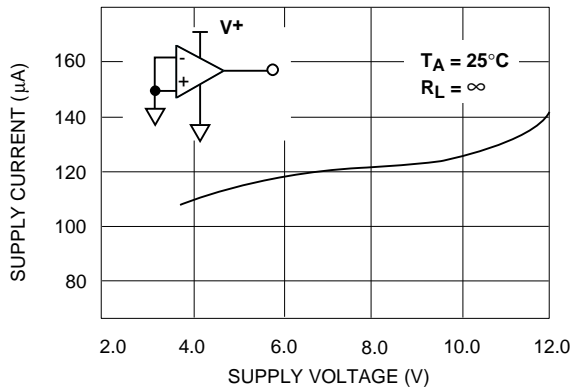

**SUPPLY CURRENT vs. TEMPERATURE**

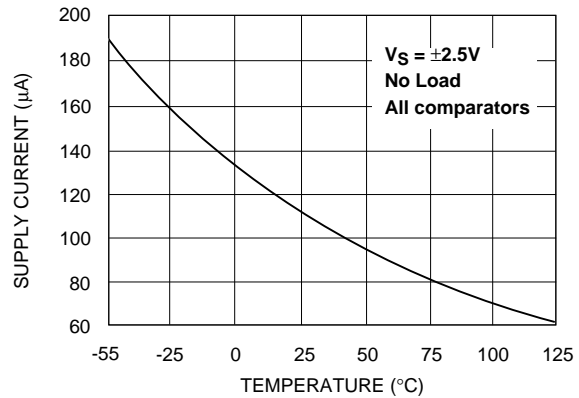

**INPUT OFFSET VOLTAGE vs. TEMPERATURE**

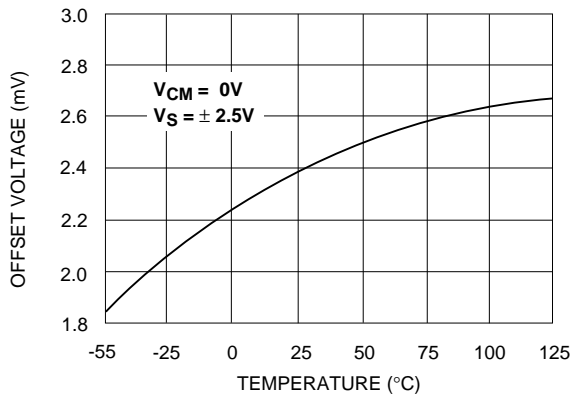

## TYPICAL APPLICATIONS

**DUAL LIMIT WINDOW COMPARATOR**

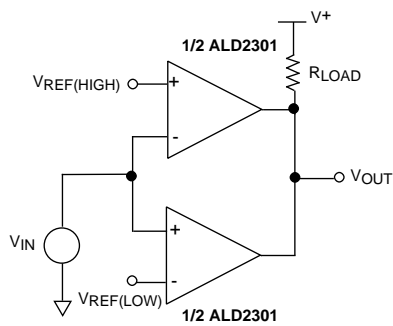

MINIMUM  $R_{LOAD} = 1.5k\Omega$

OUTPUT HIGH FOR  $V_{IN} < V_{REF(HIGH)}$   
AND  $V_{IN} > V_{REF(LOW)}$

**DUAL LIMIT PHOTO-DETECTOR MONITOR**

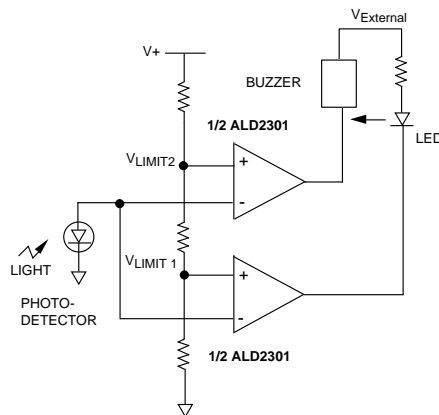

LED turns on as photo-detector voltage reaches  $V_{LIMIT1}$ . Both LED and horn turns on as photo-detector voltage reaches  $V_{LIMIT2}$ .  
 $V_{EXTERNAL} = +12V$   $V_{+} = +5V$ .

**VOLTAGE COMPARATOR WITH COMPLEMENTARY OUTPUTS**

