

VFD CONTROLLER / DRIVER

DESCRIPTION

SC16313 is a Vacuum Fluorescent Display (VFD) or Fluorescent Indicator Panel (FIP) controller/driver that is driven on a 1/4 to 1/8 duty factor. It consists of 8 segment output lines, 4 grid output lines, 4 segment/grid output lines, one display memory, control circuit, key scan circuit. Serial data is input to SC16313 via a three-line serial interface. This VFD driver is ideal as a peripheral device of a single-chip microcomputer.

FEATURES

- * CMOS technology
- * High-voltage output
- * Key scanning (8 x 2 matrix)
- * Multiple display modes: (8 segments & 8 digits to 12 segments & 4 digits)
- * 8-step dimming circuitry
- * Serial interface (CLK, DIN, DOUT, STB)
- * No external resistors needed for driver outputs

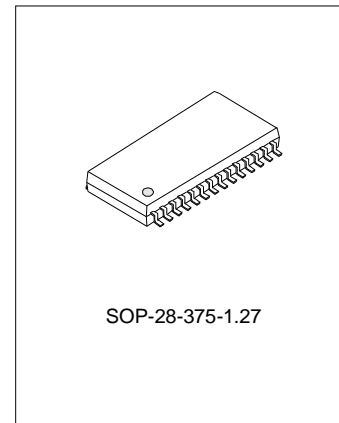

ORDERING INFORMATION

| Device | Package |
|---------|-----------------|
| SC16313 | SOP-28-375-1.27 |

APPLICATIONS

- * Microcomputer peripheral device.

BLOCK DIAGRAM

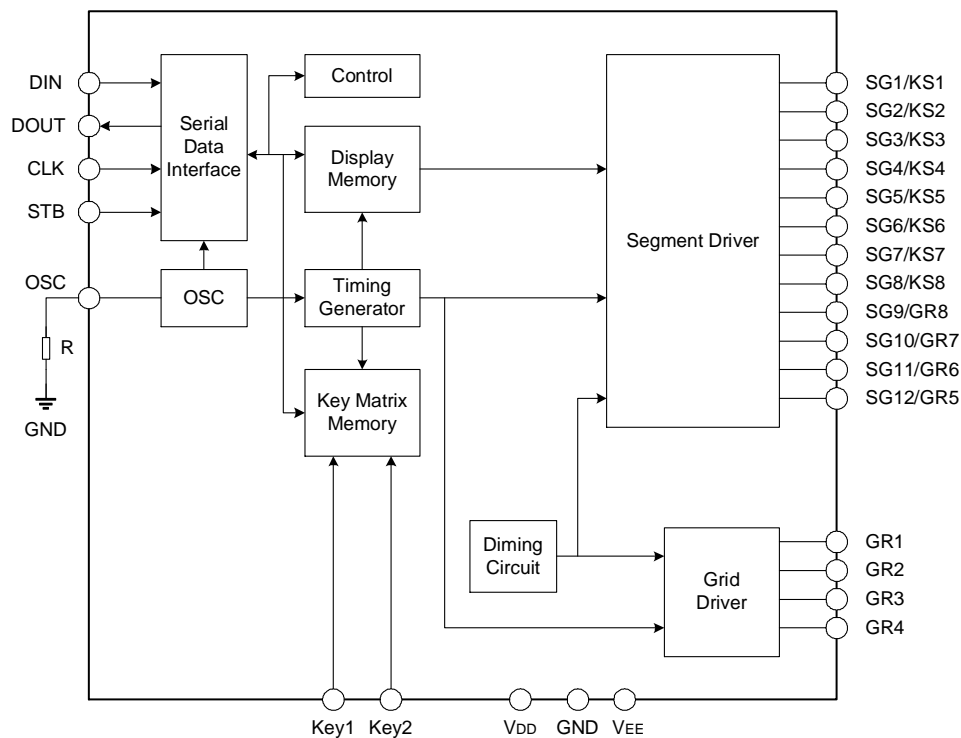

ABSOLUTE MAXIMUM RATINGS (unless otherwise stated, $T_{amb}=25^{\circ}\text{C}$, $\text{GND}=0\text{V}$)

| Characteristics | Symbol | Value | Unit |
|-------------------------------|--------|-----------------------------|--------------------|
| Logic Supply Voltage | VDD | -0.5 to +7 | V |
| Driver Supply Voltage | VEE | VDD +0.5 to VDD-40 | V |
| Logic Input Voltage | VI | -0.5 to VDD+0.5 | V |
| VFD Driver Output Voltage | VO | VEE-0.5 to VDD+0.5 | V |
| VFD Driver Output Current | IoVFD | -40 (grid) -15 (segment) | mA |
| Operating Ambient Temperature | Topr | -40 to +85 | $^{\circ}\text{C}$ |

RECOMMENDED OPERATING CONDITIONS

 (Unless otherwise stated, $T_{amb}=-20$ to $+70^{\circ}\text{C}$, $\text{GND}=0\text{V}$)

| Characteristics | Symbol | Min. | Typ. | Max. | Unit |
|--------------------------|--------|--------|------|--------|------|
| Logic Supply Voltage | VDD | 3.0 | 5 | 5.5 | V |
| High-Level Input Voltage | VIH | 0.7VDD | -- | VDD | V |
| Low-Level Input Voltage | VIL | 0 | -- | 0.3VDD | V |
| Driver Supply Voltage | VEE | VDD-35 | -- | 0 | V |

ELECTRICAL CHARACTERISTICS

 (Unless otherwise stated, $\text{VDD}=5\text{V}$, $\text{GND}=0\text{V}$, $\text{VEE}=\text{VDD}-35\text{V}$, $T_{amb}=25^{\circ}\text{C}$)

| Characteristics | Symbol | Test Condition | Min. | Typ. | Max. | Unit |
|-----------------------------|--------|---|--------|------|---------|---------------|
| Low-Level Output Voltage | VOL1 | DOUT, IOL2=4mA | -- | -- | 0.4 | V |
| High-Level Output Current | IOH21 | VO=VDD-2V SG1/KS1 to SG8/KS8 | -3 | -- | -- | mA |
| High-Level Output Current | IOH22 | VO=VDD-2V GR1 to GR4, SG9/GR8 to SG12/GR5 | -15 | -- | -- | mA |
| Input Current | Ii | VI=VDD or VSS | -- | -- | ± 1 | μA |
| High-Level Input Voltage | VIH | -- | 0.7VDD | -- | -- | V |
| Low-Level Input Voltage | VIL | -- | -- | -- | 0.3VDD | V |
| Oscillation Frequency | fOSC | R=51K Ω | 350 | 500 | 650 | KHz |
| Dynamic Current Consumption | IDDdyn | Under no load Display OFF | -- | -- | 5 | mA |

PIN CONFIGURATION

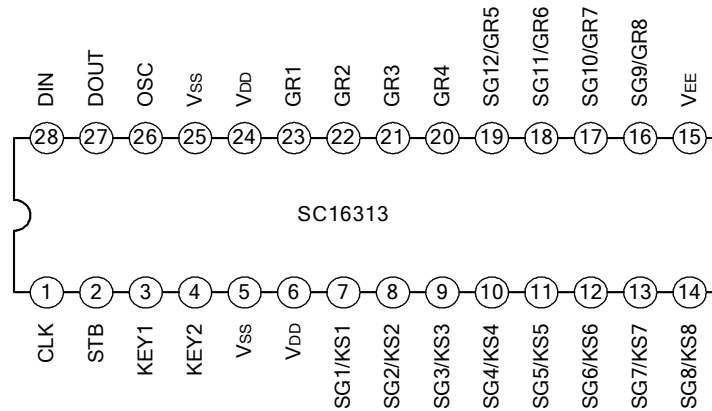

PIN DESCRIPTION

| Pin NO. | Symbol | Description |
|----------|--------------------|--|
| 1 | CLK | Reads serial data at the rising edge and outputs data at the falling edge. |
| 2 | STB | After the STB has fallen, The data input can be processed; the first data is regard as a command. When this pin is "HIGH", CLK is ignored. |
| 3, 4 | KEY1 to KEY2 | The data input to these pins is latched at the end of display cycle. |
| 5, 25 | Vss | Logic ground pin |
| 6, 24 | VDD | Logic power supply |
| 7 to 14 | SG1/KS1 to SG8/KS8 | Segment output pins. It also functions as key source. |
| 15 | VEE | VDD – 35 V max |
| 16 to 19 | SG9/GR8 ~SG12/GR5 | These pins are selectable for segment or grid output |
| 20 to 23 | GR4 to GR1 | Grid output pins |
| 26 | OSC | This pin connects a resistor to VDD to determine the oscillation frequency. |
| 27 | DOUT | Outputs serial data at the falling edge of the shift clock (starting from the lower bit). |
| 28 | DIN | Inputs serial data at the rising edge of the shift clock (starting from the lower bit). |

FUNCTION DESCRIPTION

DISPLAY RAM ADDRESS

Data transmitted from an external device to SC16313 via the serial interface are stored in the display RAM and are assigned addresses. The RAM addresses of SC16313 are given below in 8 bits unit.

| SG1 | SG4 | SG5 | SG8 | SG9 | SG12 | |
|------|-----|------|-----|------|------|-----|
| 00HL | | 00HU | | 01HL | | GR1 |
| 02HL | | 02HU | | 03HL | | GR2 |
| 04HL | | 04HU | | 05HL | | GR3 |
| 06HL | | 06HU | | 07HL | | GR4 |
| 08HL | | 08HU | | 09HL | | GR5 |
| 0AHL | | 0AHU | | 0BHL | | GR6 |
| 0CHL | | 0CHU | | 0DHL | | GR7 |
| 0EHL | | 0EHU | | 0FHL | | GR8 |

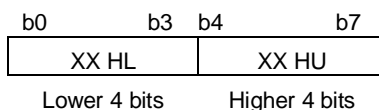

Only the lower 4 bits of the addresses assigned to SG9 through SG12 are valid, and the higher 4 bits are ignored.

SC16313 KEY MATRIX & KEY INPUT DATA STORAGE RAM

SC16313 key matrix consists of 8 x 2 arrays as shown below:

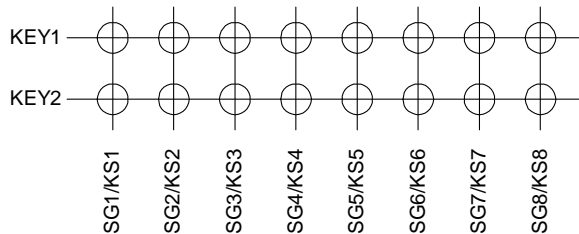

The data of each key is stored in key-input data RAM as illustrated below. They are read by a READ command, starting from the least significant bit. When the most significant bit of the data (SG8, b7) has been read, then the least significant bit of the next data (SG1, b0) will be read.

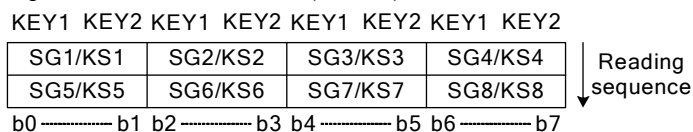

COMMANDS

Commands set the display mode and status of SC16313. The first byte (b0 to b7) inputted to SC16313 via the DIN pin after STB pin has fallen is regarded as a command. If for some reason the STB pin is made "HIGH" while data or commands are being transmitted, the serial communication is initialized, and the

Command 4: display control command

This command is used to turn ON or OFF a display. It also used to set the pulse width. Please refer to the diagram below.

ON power application, the 1/16 pulse width is set and the display is turned OFF (the key scanning starts).

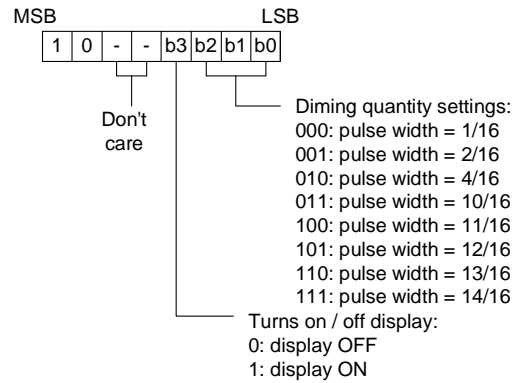

KEY SCANNING AND DISPLAY TIMING

The key scanning and display timing diagram is given below. One cycle of key scanning consists of 2 frames. In the first frame, those keys connected to KS1~KS4 are scanned, while the second frame scans KS5~KS8. The data of the 8 x 2 matrix is stored in the key-input RAM.

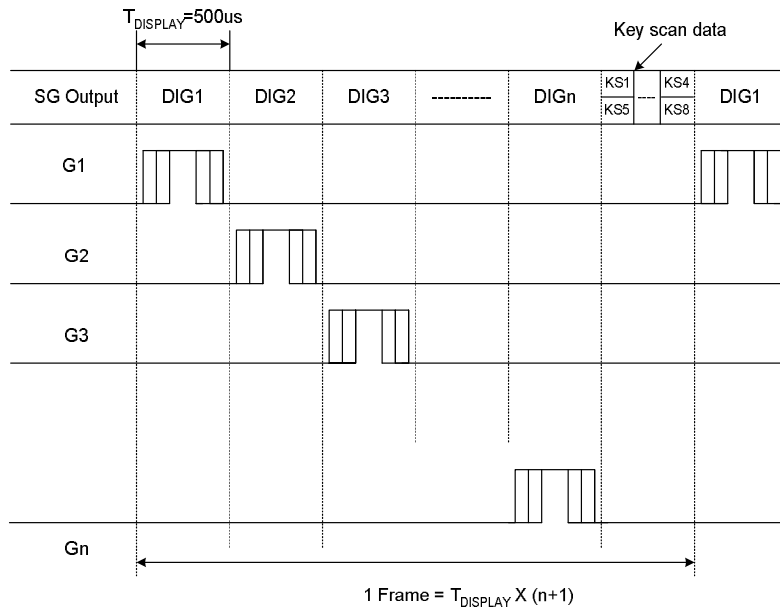

SERIAL COMMUNICATION FORMAT

The following diagram shows the SC16313 serial communication format. The DOUT pin is an N-channel, open-drain output pin. Therefore, it is highly recommended that an external pull-up resistor (1kΩ to 10kΩ) must be connected to DOUT.

RECEPTION (COMMAND/DATA WRITE)

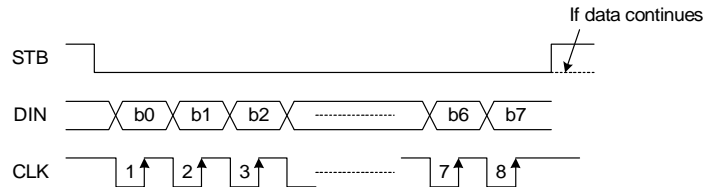

TRANSMISSION (DATA READ)

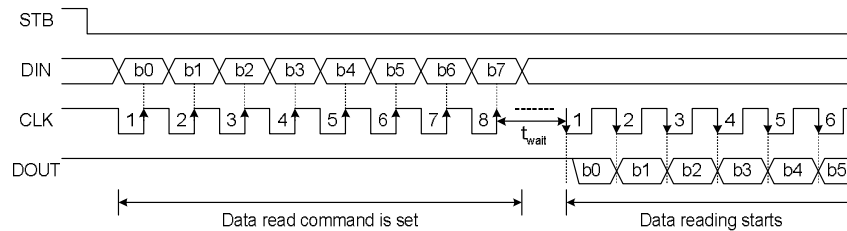

It must be noted that when the data is read, a waiting time t_{wait} of 1μs is necessary between the rising of the eighth clock that has set the command and the falling of the first clock that has read the data.

TYPICAL APPLICATION CIRCUIT

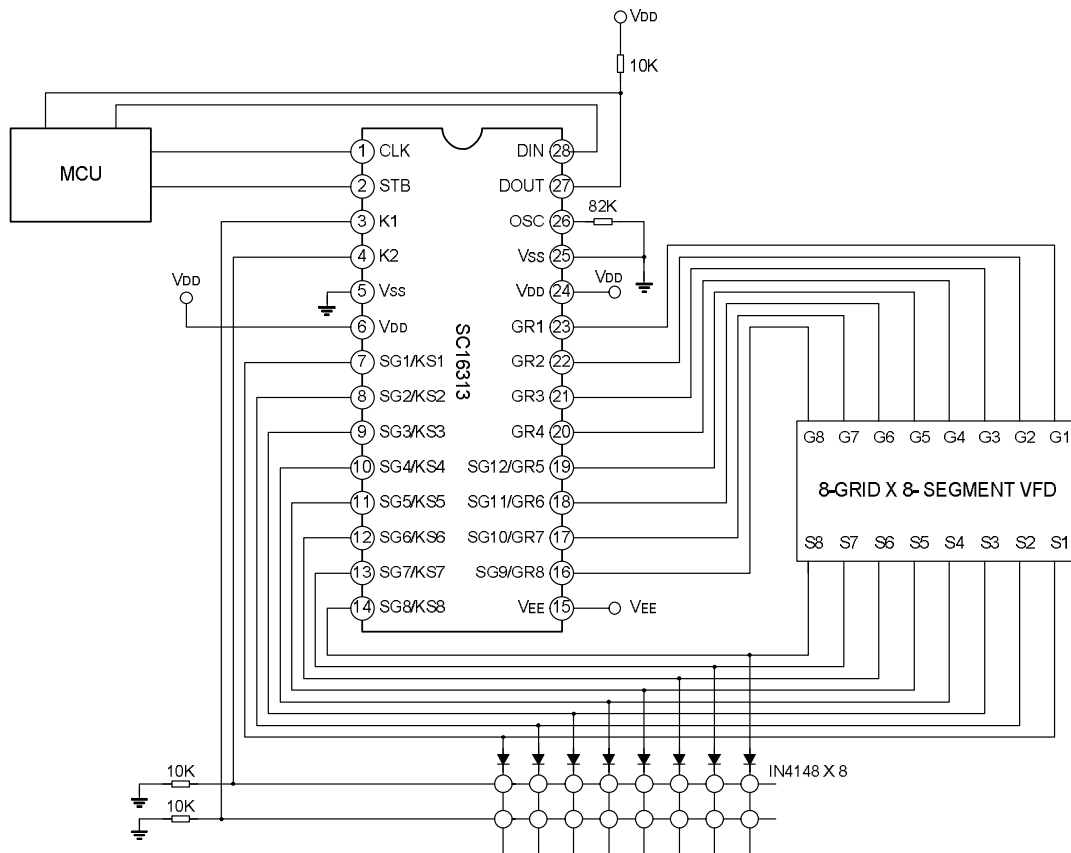

PACKAGE OUTLINE

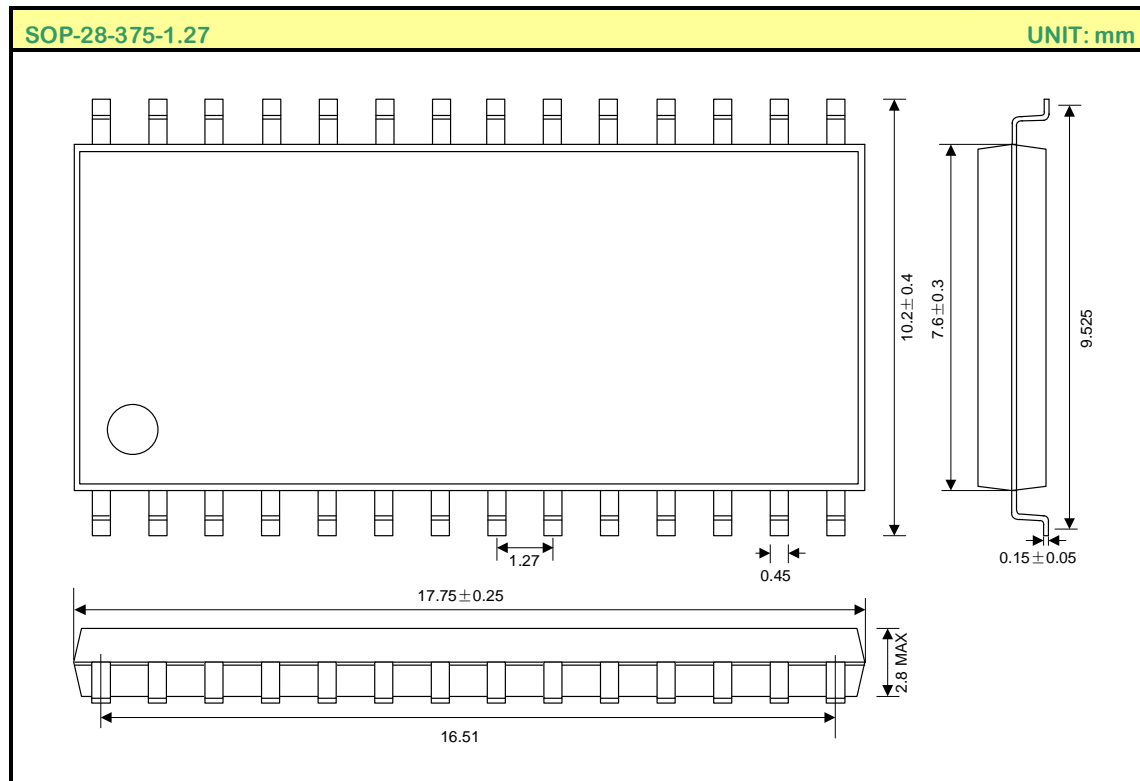

HANDLING MOS DEVICES:

Electrostatic charges can exist in many things. All of our MOS devices are internally protected against electrostatic discharge but they can be damaged if the following precautions are not taken:

- Persons at a work bench should be earthed via a wrist strap.
- Equipment cases should be earthed.
- All tools used during assembly, including soldering tools and solder baths, must be earthed.
- MOS devices should be packed for dispatch in antistatic/conductive containers.

ATTACHMENT

Revision History

| Data | REV | Description | Page |
|------------|-----|--|------|
| 2003.04.23 | 1.0 | Original | |
| 2003.07.30 | 1.1 | Del " High-Level Output Voltage" in "ELECTRICAL CHARACTERISTICS" | 3 |
| 2003.08.28 | 1.2 | Modify the pin20~pin23 pin name. | -- |