

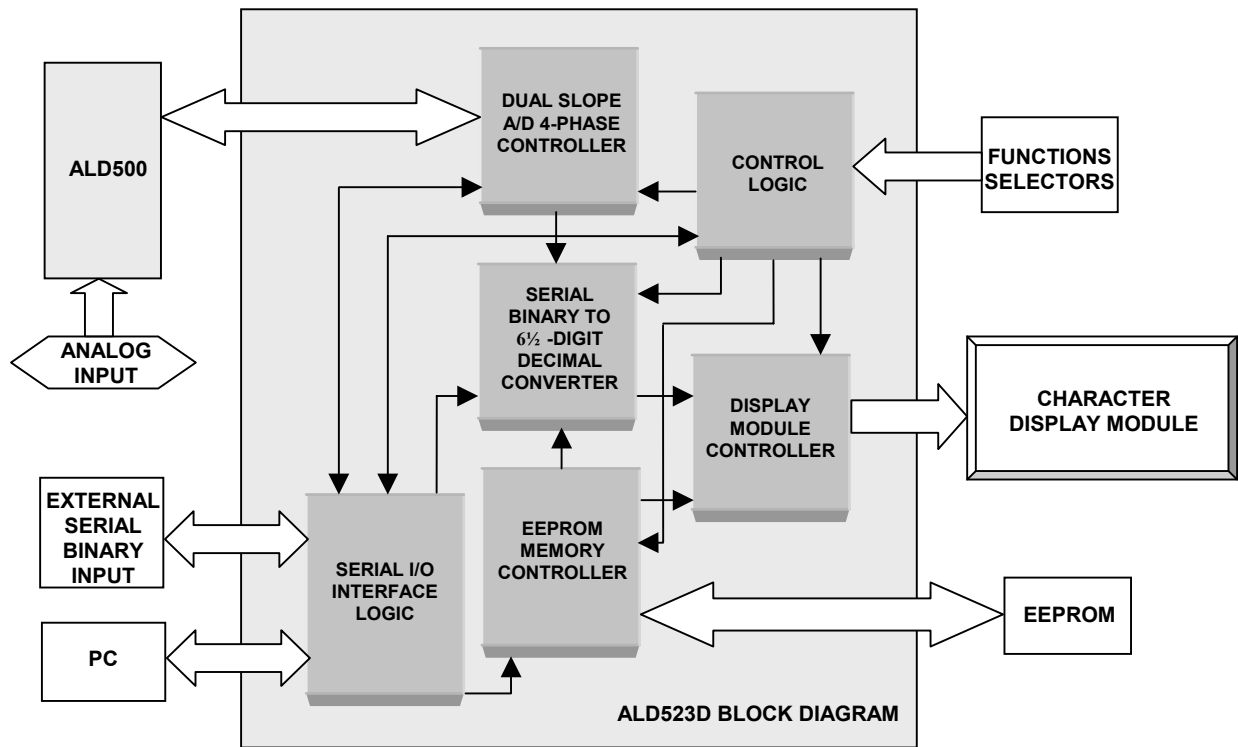

MULTIFUNCTION 7-DIGIT SERIAL INPUT DISPLAY MODULE CONTROLLER



PRODUCT FEATURES AND BENEFITS

- Up to 7 full digit plus sign (± 9999999) display
- Built-in 21 bit serial binary to $\pm 6\frac{1}{2}$ digit decimal converter
- Compatible with industry standard 1-line x 16 and 2-line x 16 Character Display Modules
- User defined 16-alphanumeric character TITLE field and up to three 8-alphanumeric character UNIT fields
- Wide range of alphanumeric display characters
- Functional with either LCD or VFD display modules with column drivers
- Designed to operate optionally with ALD500/ALD500R Precision Analog Signal Processors or directly with serial inputs
- User selected integration time and conversion speed
- Cost effective and multipurpose stand alone operation
- 3 optional modes of operation:
 - Mode A, calibrated reference mode
 - Mode B, ratiometric mode
 - Mode C, display only mode
- Support external serial binary input (up to 32 bits)
- 3-wire serial interface to microprocessors or microcontrollers
- Electrical programmable memory interface
- Crystal oscillator frequency up to 8 MHz
- Single 3V to 5V power supply
- Up to 3 separate sets of 7-DIGIT Display Sets
- 3 sets of user defined 64-bit arithmetic multiplication factor
- Software programmable serial data bit mask and sign polarity mask
- 3 different sets of user selected data sample averaging with up to maximum of 128X sampling
- Optional 13-function user configurable hardware selection switches
- Automatic zero level shifting during power-on-reset
- Automatic zero level overwrite feature
- Adjustable decimal point placement with trailing digit blanking
- External 1K EEPROM memory for easy change of factory settings
- Sleep mode with Auto Power-On-Reset.
- Easy setup of calibration and system setup parameters
- No software programming required
- PC Interface Software provided for Calibration and Setup modes

© 2001 Advanced Linear Devices, Inc., 415 Tasman Drive, Sunnyvale, California 94089-1706, Tel: (408) 747-1155, Fax: (408) 747-1286

PRODUCT APPLICATIONS

- ❑ Embedded (up to $\pm 6\frac{1}{2}$ -digit) digital panel meter
- ❑ Customized/specialized instrument display
- ❑ High precision DC voltage meters
- ❑ Dedicated precision monitors
- ❑ High resolution A/D converter with display
- ❑ High accuracy and low noise weigh scale systems
- ❑ Multifunction precision measurement instruments
- ❑ Serial binary input to decimal/character display converter
- ❑ Portable battery operated display systems.

PRODUCT ORDERING INFORMATION

OPERATING TEMPERATURE RANGE*	
0°C to +70°C	0°C to +70°C
28-Pin Plastic DIP Package (PDIP)	28-Pin Small Outline Package (SOIC)
ALD523DPH	ALD523DSH
*: Contact factory for industrial temperature range	

ALD523D PIN CONFIGURATIONS

CALIBRATED REFERENCE (MODE-A)

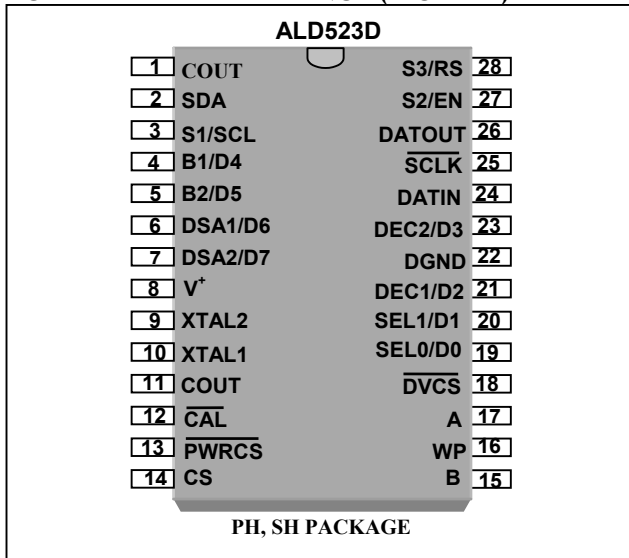

RATIOMETRIC (MODE-B)

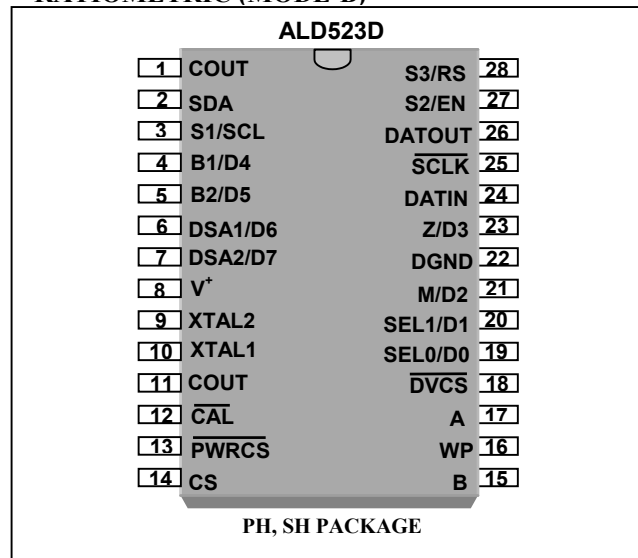

DISPLAY ONLY (MODE-C)

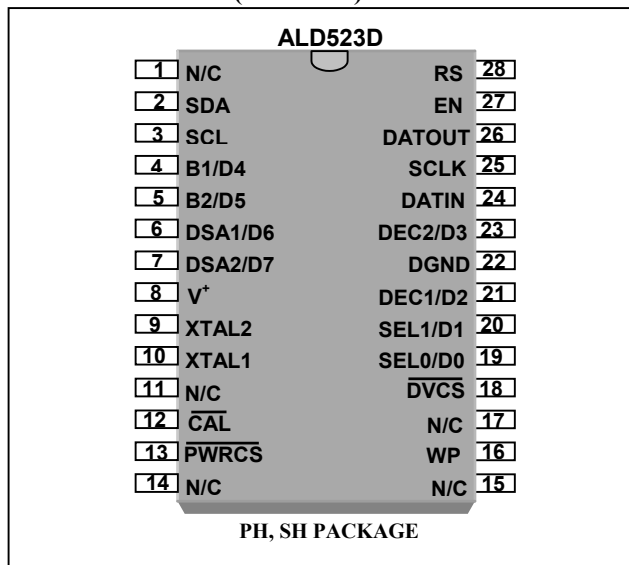

GENERAL DESCRIPTION

The ALD523D is a Multifunction 7-Digit Serial Input Display Module Controller designed to interface directly to ALD500 or ALD500R integrating dual slope precision analog processors as a chip set for building a high precision and high accuracy analog-to-digital converter system with auto zero and auto-polarity. The ALD523D also functions as an universal serial input 7-digit display module controller that interfaces to most popular industry standard serial data formats from other microprocessors or data converters. It is designed for easy setting of industry standard Character Display Modules (CDM) such as 1-line by 16-character or 2-line by 16-character LCD or VFD display modules. The ALD523D is an enhanced version of the ALD521D digital controller. The ALD523D functions in three separate operating modes, namely calibrated reference (mode-A), ratiometric (mode-B), and display only (mode-C).

The ALD523D digital controller operates as a master display module controller in either a stand-alone mode or in an external microprocessor control mode. In the external microprocessor control mode, the ALD523D can directly interface with a PC under PC software control via a standard parallel printer port. This external control mode is managed by the Serial I/O Interface Logic inside the ALD523D.

In the stand-alone mode, the ALD523D makes continuous measurements, and includes all the necessary functions to fully control a CDM. In the stand-alone mode, ALD523D operates in conjunction with a 1K EEPROM chip to preserve the setup parameters and arithmetic (calibration) parameters of the ALD523D.

The setup and arithmetic parameters are uploaded to the EEPROM via ALD523D Setup and Calibration PC software (DVM523). The ALD523D communicates to the EEPROM on a handshake protocol governed by the EEPROM Memory Controller inside the ALD523D.

The ALD500/ALD500R dual slope precision analog processors consist of on-chip digital control circuitry to accept control inputs, integrating buffer amplifiers, analog switches, and voltage comparators. It functions in four operating phases, namely auto zero, integrate, de-integrate, and integrator zero phases. At the end of a conversion, the comparator output goes from high to low when the integrator crosses zero during de-integration. ALD500/ALD500R dual slope precision analog processors also provide direct logic interface to ALD523D.

The ALD523D implements the logic and timing for all the four phases of the ALD500/ALD500R, namely auto zero, integrate, de-integrate, and integrator zero phases in mode-A and mode-B operations. These four phases are governed by the Dual Slope A/D 4-Phase Controller inside the ALD523D. The ALD523D operates from an external clock or its internal oscillator circuit along with an external crystal. The internal system clock of the ALD523D runs at a frequency which can be selected at divide-by N (4, 8, or 64) rate of the crystal (or external) clock frequency.

The ALD523D offers up to 3 display settings, known as display sets, namely "DGS1", "DGS2" and "DGS3". "DGS1" also has an optional hardware decimal point setting mode, known as "DGS0", which allows the user to use hardware jumper switches to set decimal point position. Each display set allows a full 7-digit decimal number to be converted from a 16-bit to 32-bit serial binary number using the Serial Binary To 6½-Digit Decimal Converter inside the ALD523D. This 6½-digit decimal number can also be scaled by a MULTIPLIER number, and the result of the scaled number displayed on the CDM through the Display Module Controller within the ALD523D. Additional display parameters that can be manipulated are: Digit Blanking, which allows user selection of number of digits to display; Decimal Point placement, which controls placement of decimal point, if any. Up to 3 sets of display UNIT fields are available, each with a combination of alphanumeric characters up to 8 characters long.

The ALD523D also features hardware control-input pins for power down ($\overline{\text{PWRC}}\text{S}$), integration time selection (S1, S2 and S3), data sample averaging (DSA1 and DSA2), digit blanking (B1 and B2), decimal point placement (DEC1 and DEC2), zero offset (M and Z), and display set selection (SEL0 and SEL1). When not used, or if no control is desired, each of these optional pins are wired to their respective desired logic state, either V^+ or Ground (DGND), through pull-up or pull-down resistors. The functions of the control-input pins are managed by the Control Logic section in the ALD523D.

MODES OF OPERATIONS

The ALD523D functions in either single operating mode or multiple operating modes, namely calibrated reference (mode-A), ratiometric (mode-B), and display only (mode-C). In the single operating mode, ALD523D operates in one of the three modes of operation, either mode-A, mode-B or mode-C. In the multiple operating modes, the ALD523D can operate interchangeably in each of the three

different operating modes. This feature becomes useful for applications that require multiple modes of operations where up to three different types of measurements are made and displayed.

I. CALIBRATED REFERENCE MODE (MODE-A)

The calibrated reference mode (mode-A) is primarily intended for measurements against a calibrated reference voltage. The reference voltage can either be internal or external. In this mode, the ALD523D runs its internal analog-to-digital controller to manage data conversion from an analog-to-digital converter chip with calibrated reference voltage such as the integrating dual slope precision analog processors ALD500R. One of the practical applications of utilizing this mode of operation is a precision digital voltmeter system design (see the Application Design Note-AN523DA).

In this mode, ALD500 can also be used instead of the ALD500R, with an external voltage reference. The block diagram of mode-A is shown in figure 1. See ALD523D pin configuration and identification section for mode-A pin layout and description.

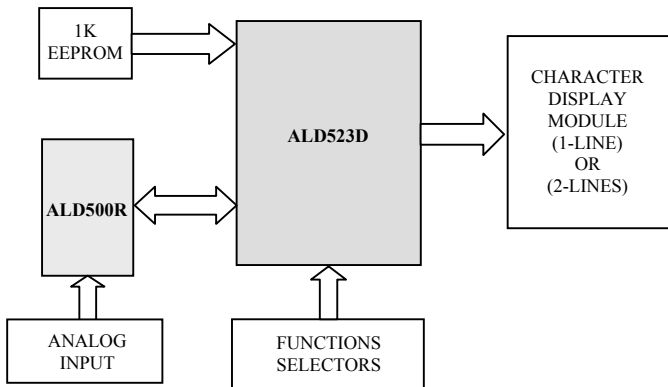

Figure 1. Calibrated reference mode (mode-A) block diagram.

II. RATIOMETRIC MODE (MODE-B)

The ratiometric mode (mode-B) is primarily intended for measurements against a ratiometric reference voltage. In this mode, the ALD523D runs its internal analog-to-digital controller to manage data conversion from an analog-to-digital converter chip such as the integrating dual slope precision analog processors ALD500 with ratiometric reference voltage. One of the practical example applications of utilizing this mode of operation is a precision weigh scale system design (see the Application Design Note-AN523DB). The block diagram of mode-B

is shown in figure 2. See ALD523D pin configuration and identification section for mode-B pin layout and description.

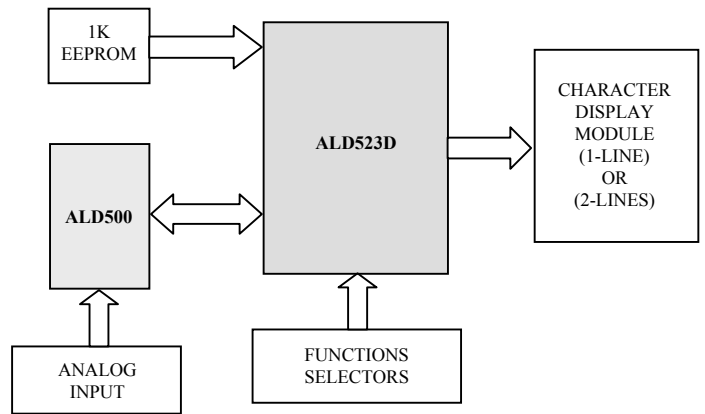

Figure 2. Ratiometric mode (mode-B) block diagram.

III. DISPLAY ONLY MODE (MODE-C)

The display only mode (mode-C) is primarily intended for receiving a ready external serial binary data, converting and processing the data, and showing the processed data on the CDM. In this mode, the ALD523D runs its internal display controller to manage, process, and display the received serial binary data from a transmitting instrument or device. One of the applications of utilizing this mode of operation is an external interface to ALD MB1S precision digital voltmeter system. The block diagram of mode-C is shown in figure 3. See ALD523D pin configuration and identification section for mode-C pin layout and description.

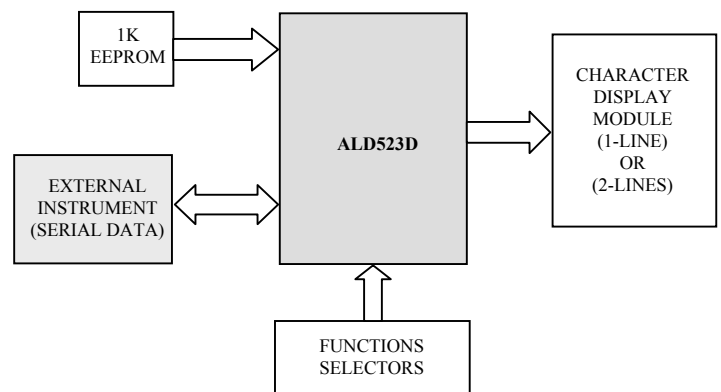

Figure 3. Display only mode (mode-C) block diagram.

ALD523 SETUP AND CALIBRATION SOFTWARE

In the stand-alone mode, ALD523D operates in conjunction with a 1K EEPROM chip to preserve the setup and arithmetic (calibration) parameters of the ALD523D. These parameters are utilized to fully control the CDM and measurement functions. The parameters are preset by the user through the ALD523D Setup and Calibration PC software known as DVM523.EXE, and later uploaded to the EEPROM via a standard parallel printer port. See the ALD523D Setup and Calibration User Guide (DVM523) for more details.

SELECTING AND CONFIGURING MODES OF OPERATIONS

The three ALD523D modes of operations, namely mode-A, mode-B, and mode-C are configured in the .CDS file (see Table 1 of the ALD523D Setup and Calibration Software User Guide), and are selected by means of user selection of SEL0 and SEL1 control inputs of the ALD523D. Each display set “DGSx” has an associated mode parameter “Mx” which specifies the mode of operation. Hence, “DGS1”, “DGS2”, and “DGS3” have 3 associated mode specifying parameters “M1”, “M2”, and “M3”, respectively. Each “Mx” parameter can be preset to either “Mode-A”, “Mode-B”, or “Mode-C”.

I. CALIBRATED REFERENCE MODE (MODE-A)

Mode-A can be selected by setting the nibble “M1” parameter, or “M2” or “M3” of the byte “M2-M3” parameter to an “A” (HEX) in the .CDS file. “M1”, “M2”, and “M3” are the mode selection parameters associated with “DGS1”, “DGS2”, and “DGS3” display sets, respectively.

In mode-A or mode-B operation, the bit masking “SMSK1” to “SMSK4” and the polarity bit masking “SMSK5” to “SMSK8” parameters are not utilized. However, this mode transmits a 24-bit serial word on pin 26, DATOUT. This 24-bit serial word consists of 23-bit binary data with MSB as the first bit, LSB the 23rd bit, followed by a sign bit as the last bit. The sign bit is a logical “1” as a positive sign, and logical “0” as a negative sign.

II. RATIOMETRIC MODE (MODE-B)

Mode-B can be selected by setting the nibble “M1” parameter, or “M2” or “M3” of the byte “M2-M3” parameter to an “B” (HEX) in the .CDS file.

When the ALD523D is powered up the first time or after power-on-reset, a zero correction is automatically set by zeroing out the reading. This automatic zero correction feature can be manually overwritten by the Z switch (see Table 5) at any time. The overwrite feature is embedded to eliminate the long wait time at long integration time, and add flexibility to perform zero correction at any time. However, the faster the integration time set, the less the wait time is needed to perform the automatic zero correction (i.e. it takes typically from about 1 to 14 seconds to automatically zero out a reading for integration time of 16.66 ms to 300 ms, respectively).

III. DISPLAY ONLY MODE (MODE-C)

Mode-C can be selected by setting the nibble “M1” parameter, or “M2” or “M3” of the byte “M2-M3” parameter to an “C” (HEX) in the .CDS file. In mode-C operation, switches “S1”, “S2”, and “S3” are internally disabled.

In mode-C operation, the ALD523D receives a maximum serial word length of 32 bits in accordance to 32 serial clock pulses, and processes a maximum of 21-bit serial word plus 1 sign bit within this 32-bit serial word. This 21-bit serial word can be any 21-bit consecutive serial data stream segment within the 32-bit serial clocks, as selected by programming of the bit masks “SMSK1” through “SMSK4”. The length of the received serial word is governed by a \overline{DVCS} signal. A transition of \overline{DVCS} from high to low state signals the start of the serial input data bit stream clocking. A transition of \overline{DVCS} from low to high state stops the serial input data bit stream clocking.

After an external instrument or processor sets the \overline{DVCS} to logic 0, the DATIN terminal of the ALD523D is ready for serial input data stream. The ALD523D reads the first bit of the serial input data stream on DATIN and sends a serial clock pulse on the SCLK as an acknowledge signal to the external instrument or processor. Then the ALD523D reads the second bit of the serial input data stream and sends out a second SCLK clock pulse. This serial data reading and clocking process continues until \overline{DVCS} is set to high state or until a maximum of 32 serial input data bits have been read. The serial clock SCLK consists of a low to high transition followed by a high to low transition.

The maximum converted decimal number from this 21-bit binary data plus sign bit is ± 9999999 , when a suitable multiplier and an appropriate conversion factor are used. The sign bit is defined as logic “0” as a positive sign, and logic “1” as a negative sign. Alternatively, the sign bit

polarity and the serial clock SCLK polarity can be inverted, as described in the next section.

The positions of the serial data bits and sign bit within a given serial data word are determined by the 32 bit data bit mask register “SMSK1” to “SMSK4” and the 32 bit sign bit mask register “SMSK5” to “SMSK8” parameters in the .CDS file. Bit masking rules are as follows:

1. Maximum serial word length that the ALD523D can receive are 32 bits in 32 SCLK clock cycles. One of the serial bits can be optionally a sign bit. If a serial word has less than 32 bits, the last clock of the SCLK clock stream when \overline{DVCS} goes from a “0” to a “1” stops the data word counter.
2. Maximum serial data bits that the ALD523D can process are 21 bits plus 1 sign bit for a total of 22 bits.
3. Minimum serial data bits that the ALD523D can process are 2 bits, including a sign bit. The number of clock cycles between when \overline{DVCS} goes from “1” to “0” to when \overline{DVCS} goes from “0” to “1” defines the total input serial word length, right justified, from bit 0 of the 32 bit input mask register.
4. The input serial data bits must be in a consecutive order, from MSB bit first to LSB bit last.
5. The sign bit can be anywhere outside the serial data bits stream but within the serial data word.

BIT AND SIGN MASKING

Bit masking is set by the user by programming SMSK1 through SMSK4 from memory address 60H to 63H. SMSK1 indicates the position of the first 8 bits of a 32-bit serial data word mask. SMSK2, SMSK3 and SMSK4 indicates the position of the next 24 bits of the 32-bit serial data word mask, respectively. Initially, all 32 bits are set to 0. When the last “1” bit is set anywhere within the 32 bit serial data word, it sets the LSB bit position. The “1” bit starts at MSB, followed by “1” bits, until the LSB bit is reached. After the LSB bit, any subsequent bit must be left as “0” bits. The number of “1” bits between MSB bit and the LSB bit determines the length of the serial data word.

	SMSK1	SMSK2	SMSK3	SMSK4
	Byte-1	Byte-2	Byte-3	Byte-4
Binary	00000000	00001111	11111111	11110000
Hexadecimal	00	0F	FF	F0

bit31 bit0

Table 1. Serial data bit masking technique.

Table 1 illustrates an example of the serial bit masking technique. In this example, there are 23 SCLK clock cycles, a sign bit and a 16 bit data word. SCLK clock starts at bit 7 of SMSK2. MSB starts on the 4th clock cycle, or

bit 4 of SMSK2, of the serial data stream. Data is being continuously clocked into the ALD523D until the 23rd clock cycle or until \overline{DVCS} goes from “0” to “1”. The LSB of the data word is positioned at the 19th clock cycle. The length of the serial word is determined by the number of consecutive “1” in the masking bits, which is 16 bits.

Sign masking is set by the user by programming SMSK5 through SMSK8 from memory address map 64H to 67H. Initially, all 32 bits from SMSK5 to SMSK8 are set to 0. A “1” bit anywhere between SMSK5 through SMSK8 indicates the position where the sign information is located. There can only be one “1” bit within the 32-bit serial data stream, situated outside the serial data bit stream, and all remaining bits must be “0” bits. In this example, the data word has 23 clock cycles. Table 2 illustrates the example of sign bit masking technique. The sign bit data is available on the first clock cycle of the 23-bit data word stream. In this example, placing a “1” anywhere between the fourth bit of SMSK6, through all the bits of SMSK7, until the fifth bit of SMSK8, corresponding to between the 4th clock cycle to the 19th SCLK clock cycle, is not allowed. This example is also valid for any number of SCLK, between 23 and 32, of the input data word, while \overline{DVCS} is low.

	SMSK5	SMSK6	SMSK7	SMSK8
	Byte-5	Byte-6	Byte-7	Byte-8
Binary	00000000	01000000	00000000	00000000
Hexadecimal	00	40	00	00

bit31 bit0

Table 2. Sign bit masking technique.

In default mode, the sign bit is defined by logic “0” as a positive sign, and logic “1” as a negative sign, and the serial clock is SCLK. As an option, the sign bit and the serial clock polarity can be inverted by setting “Mx” equal to “D” (HEX) instead of “C” (HEX). The serial clock now becomes \overline{SCLK} , and the sign bit polarity is defined as logic “1” for a positive sign, and logic “0” for a negative sign (see Table 1 of the ALD523D Setup and Calibration Software User Guide).

SELECTING AND CONFIGURING DISPLAY LINE WITH FREQUENCY MODE AND INPUT CLOCK DIVIDER

The ALD523D is designed to be compatible with industry standard 1-line x 16-character and 2-line x 16-character CDM, and to operate under different input frequencies of the clock source. This feature is programmable through the “SETF” parameter in the .CDS file. The “SETF” parameter is a 4-bit hexadecimal number (0-B) located on the first line of the .CDS file, and corresponds to address 00H of the EEPROM.

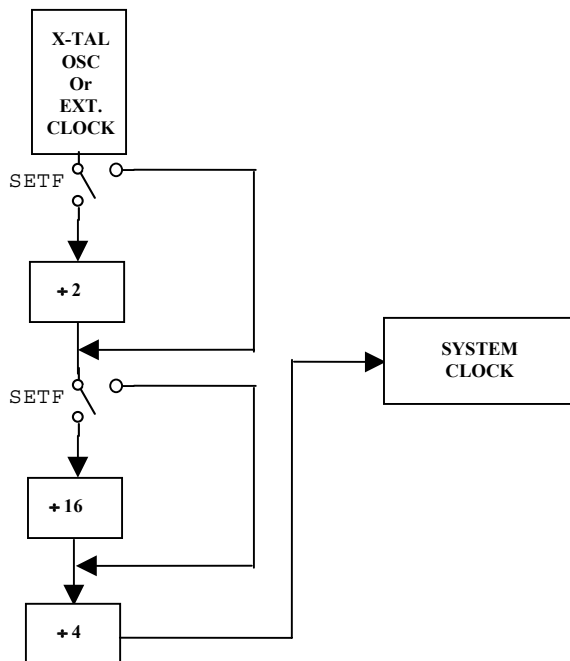

Figure 4. Programmable input frequency divider of the clock source.

The 4-bit hexadecimal number defines the selection of either 1-line x 16-character or 2-line x 16-character display, along with the operating frequency modes (low or high) and the input frequency dividers of 4, 8, and 64, respectively. The low or high frequency mode operates the ALD523D in the low emission mode or standard mode, respectively. The input frequency divider further scales down the input clock source from a divide by 4 by any integer number of 1, 2, and 16 as illustrated in figure 4.

SELECTING AND CONFIGURING DISPLAY TITLE LINE

With the ALD523D, one 16-character display TITLE line field can be custom programmed according to user's choices, and displayed on the first line of the 2-line by 16-character CDM. The characters of this TITLE line field is configured through "TTL1" to "TTL16" parameters, which are 16-byte hexadecimal numbers located on the second and third lines of the .CDS file, and corresponds to addresses from 08H to 17H of the EEPROM memory address map (see Table 3 character codes and patterns in the ALD523D Setup and Calibration Software User Guide). TITLE line field is not displayed when 1-line by 16-character display is used.

DATA & UNIT DISPLAY LINE

The first line of the 1-line x 16-character or the second line of the 2-line x 16-character CDM is divided into a DATA field and a UNIT field, as illustrated in figure 5. The ALD523D converts a 24-bit plus sign bit serial data stream to a 7-digit decimal number with +/- sign. The 7-digit number, when displayed with +/- sign and a decimal point, takes up a total of 9 characters. This 7-digit number is displayed in the DATA field starting on the first character of a 1-line CDM and starting on the first character of the second line of a 2-line CDM.

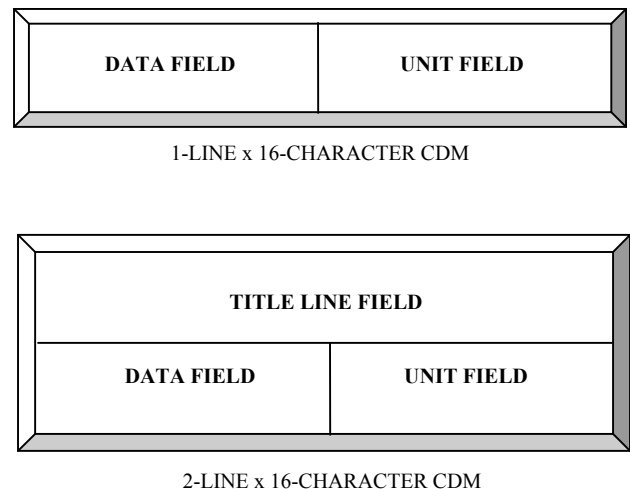

Figure 5. Character Display Module TITLE, DATA, and UNIT fields.

The remaining characters of the 16-character line of the CDM are used as UNIT character displays. The user can put any combination of characters in the remaining character fields. In general, these characters are used as a display of a UNIT of measure, such as "VOLT" or "KILOGRAM" or "PSI".

A maximum of 8 characters can be displayed in the UNIT field. However, if the first character of the UNIT field is a "blank", or 20 (HEX), then a full 7 digit plus sign and decimal point can be displayed. Otherwise, only a maximum of 6 digit plus sign and decimal point are displayed, as the last digit of the 7 digit number is overwritten by the UNIT display character.

For example, using "KILOGRAM" as a UNIT display, maximum digits displayed are 6 digits. In order to have 7 digits displayed, the UNIT label may be changed to "_KGM" where the first character of the 8-character UNIT field is a blank character 20 (HEX).

SELECTING AND CONFIGURING DISPLAY SETTINGS

The ALD523D uses SEL0 and SEL1 control-input pins for selecting different display sets “DGS0”, “DGS1”, “DGS2”, and “DGS3”. Each display set “DGSx” has an associated mode of operation “Mx”, unit display “UNTx”, decimal point placement “LxDEC”, and multiplier scale factors “±CALx”, where x=0, 1, 2 or 3.

The SEL0 and SEL1 switches have 4 logical states of operations as described in Table 3. Each logical state combination selects different measurement labels/units, scale factors, decimal point location, and mode selections. In all modes of operation, the SEL0 and SEL1 software switch setting selections override the hardware jumper functions of the DEC1 and DEC2 or M and Z switches when either SEL0 or SEL1 are set to logical “1”.

When **SEL0=0** and **SEL1=0**, the ALD523D selects display set “DGS0”, which consists of a combination of “M1”, “UNT1”, “+CAL1” and “-CAL1” parameters from addresses 00H, 18H to 1FH, 30H to 37H, and 38H to 3FH of the EEPROM memory, respectively. In the calibrated reference mode (mode-A) and the display only mode (mode-C), DEC1 and DEC2 hardware jumper switches are used to place decimal point. In mode-B operation, no decimal point is displayed.

When **SEL0=1** and **SEL1=0**, the ALD523D selects display set “DGS1”, which consists of a combination of “M1”, “L1DEC”, “UNT1”, “+CAL1” and “-CAL1” parameters from addresses 00H, 05H, 18H to 1FH, 30H to 37H, and 38H to 3FH of the EEPROM memory, respectively. The decimal point is placed according to the content of the “L1DEC” parameter.

When **SEL0=0** and **SEL1=1**, the ALD523D selects display set “DGS2”, which consists of a combination of “M2”, “L2DEC”, “UNT2”, “+CAL2” and “-CAL2” parameters from addresses 01H, 06H, 20H to 27H, 40H to 47H, and 48H to 4FH of the EEPROM memory, respectively. The decimal point is placed according to the content of the “L2DEC” parameter.

When **SEL0=1** and **SEL1=1**, the ALD523D selects display set “DGS3”, which consists of a combination of “M3”, “L3DEC”, “UNT3”, “+CAL3” and “-CAL3” parameters from addresses 01H, 07H, 28H to 2FH, 50H to 57H, and 58H to 5FH of the EEPROM memory, respectively. The decimal point is placed according to the content of the “L3DEC” parameter.

Each of the “M1”, “M2”, and “M3” parameters is a 4-bit hexadecimal number located on the first line of the .CDS file (see Table 1 of the ALD523D Setup and Calibration Software User Guide for the data sheet layout). Each of these “M1”, “M2”, and “M3” parameters can have content data of “A”, “B”, “C” or “D” which corresponds to mode-A, mode-B, mode-C default mode, or mode-C clock and sign bit inverted polarity mode, respectively.

Each of the “L1DEC”, “L2DEC”, and “L3DEC” parameters is an 8-bit hexadecimal number at addresses 05H, 06H, and 07H of the first line location of the .CDS file, respectively.

GROUP	J1						
FUNCTION	DISPLAY SETTING						
PIN	19	20	DISPLAY SET	OPERATION			
SWITCHES	SEL0	SEL1		UNIT	MULTIPLIER	DECIMAL	MODE SELECTION
	0	0	DGS0	UNT1	±CAL1	J2/NoDec	M1
	1	0	DGS1	UNT1	±CAL1	L1DEC	M1
	0	1	DGS2	UNT2	±CAL2	L2DEC	M2
	1	1	DGS3	UNT3	±CAL3	L3DEC	M3

Table 3. Display setting switch configurations and operations.

In **mode-A** operation, the conversion factor “±CAL1” parameters resulted from hardware calibration, and they are scaled through the use of scale factor parameter “N1” specified inside the DVM523.EXE program. The “±CAL2” and “±CAL3” parameters are obtained from scaling the conversion factor “±CAL1” through the scale factor parameters “N2” and “N3” specified inside the DVM523.EXE program, respectively. See Scale Conversion Factor (#2 Key) section in the ALD523D Setup and Calibration Software User Guide on how to implement these “N1”, “N2”, and “N3” scale factors.

In **mode-B** operation, the conversion factor “±CAL1” parameters are generated from a ratiometric reference value from the .MDS file, or from inputting “+CAL1” and “-CAL1” conversion factors directly into the Input Conversion Factor screen of the DVM523.EXE via the keyboard. These conversion factors “±CAL1” can be scaled through the scale factor parameter “N1” from the DVM523.EXE program. The “±CAL2” and “±CAL3” parameters are obtained from scaling the conversion factor “±CAL1” values through the scale factor parameters “N2” and “N3” from the same Input Conversion Factor screen, respectively. See Scale Conversion Factor (#2 Key) or Input Conversion Factor = CAL1 (µV/CT) (#M Key) section in the ALD523D Setup and Calibration Software User Guide for implementation details.

In **mode-C** operation, the conversion factor “±CAL1” parameter is defined from inputting “+CAL1” and “-CAL1” conversion factors which are scaleable through the scale factor parameter “N1” from the Input Conversion Factor screen of the DVM523.EXE program. The “±CAL2” and “±CAL3” parameters are obtained from scaling the conversion factor “±CAL1” through the scale factor parameters “N2” and “N3” from the same Input Conversion Factor screen. See Input Conversion Factor = CAL1 (µV/CT) (#M Key) section in the ALD523D Setup and Calibration Software User Guide for more information.

The “UNT1” parameter consists of 8 1-byte hexadecimal numbers consisting of “UNT11” to “UNT18” parameters located on the fourth line of the .CDS file (see Table 1 and Table 3 of the ALD523D Setup and Calibration Software User Guide for the data sheet layout and the hexadecimal codes, respectively). When “DGS0” or “DGS1” display set is selected, each 1-byte hexadecimal number specifies an alphanumeric character as defined in CG ROM table of the CDM. When the “UNT11” parameter is set to a space character (20H), up to a full 7-digit number is displayed followed by a 7-character label in the UNIT field on the CDM. Otherwise, a 6-digit number is displayed followed by an 8-character label in the UNIT field. Similarly,

“UNT2” and “UNT3” parameters can be set up and displayed on the CDM when “DGS2” and “DGS3” display sets are selected.

SELECTING AND CONFIGURING DECIMAL POINT PLACEMENT OR ZERO OFFSET

In **mode-A** and **mode-C** operations, the DEC1 and DEC2 switches correspond to the input pins 21 and 23 of the ALD523D, respectively. They are functionally grouped into J2. In either mode-A or mode-C operation, DEC1 and DEC2 switches are jumper hardware switches used to specify the location of placement of the decimal point of the displayed reading. DEC1 and DEC2 switch setting combinations are described in Table 4.

GROUP	J2		
FUNCTION	DECIMAL POINT PLACEMENT SETTING		
PIN	21	23	
SWITCHES	DEC1	DEC2	DECIMAL POINT PLACEMENT
LOGIC LEVEL	0	0	XXXXXXXX
	1	0	X . XXXXXX
	0	1	XX . XXXXX
	1	1	XXX . XXXX

Table 4. Decimal Point setting switch combination for mode-A and mode-C.

DEC1 and DEC2 hardware jumper switches are only functional when display set “DGS0” is selected.

When **DEC1=0** and **DEC2=0**, ALD523D instructs the display to display the entire number without a decimal point.

When **DEC1=1** and **DEC2=0**, ALD523D displays the number with a decimal point placed after the first digit.

When **DEC1=0** and **DEC2=1**, the ALD523D utilizes this information to display the number with a decimal point placed after the second digit.

When **DEC1=1** and **DEC2=1**, the ALD523D sets the display to display the number with a decimal point placed after the third digit.

This function effectively allows scaling of the displayed reading. For example, the reading may display 123.456 Volt in one range and 0.123456 KiloVolt in another display set of the same range.

Decimal placement is also programmed by software parameters “L1DEC”, “L2DEC”, “L3DEC” which are selected as part of display set selections. “L1DEC”,

“L2DEC”, and “L3DEC” are 3 separate decimal point placement instruction commands, each associated with display set “DGS1”, “DGS2”, and “DGS3”, respectively.

Each command uses the same format, and has valid parameters as “00”, “01”, “02”, “03”, “04”, and “05”. “00” instructs the display module to display no decimal point. “01” instructs the display module to display a decimal point after the 1st digit. “02” instructs the display module to display a decimal point after the 2nd digit. “03” instructs the display module to display a decimal point after the 3rd digit. “04” instructs the display module to display a decimal point after the 4th digit. “05” instructs the display module to display a decimal point after the 5th digit.

In **mode-B** operation, the DEC1 and DEC2 switches change function and become M and Z switches in order to perform a zero level adjustment. The M and Z switches correspond to the control input pins 21 and 23 of the ALD523D, respectively. They are functionally grouped into J2. M and Z pins set logical states of operations as described in Table 5.

GROUP	J2		
FUNCTION	ZERO LEVEL		
PIN	21	23	
SWITCHES	M	Z	OPERATION
LOGIC LEVEL	0	X	ZERO LEVEL SHIFTING OFF
	1	0	ZERO LEVEL SHIFTING ON
	1	1	SET ZERO LEVEL

Table 5. Zero level switch configurations and operations for mode-B.

The M switch is the master control switch, which controls the Z switch. When the M=0, the Z switch function is disabled, and the zero offset value is included in the displayed reading. When M=1, zero level shifting is turned on. At M=1 and Z=1, a zero level is indicated on the CDM and the zero offset value is stored inside the controller’s memory registers. When the M=1 and Z=0, a reading with zero level shifting is displayed. In this mode, the zero offset value previously stored is read back from the controller’s memory registers and subtracted from the current reading. The displayed reading now has automatic zero correction. This function is analogous to the TARE button in many weigh scales.

SELECTING AND CONFIGURING DIGITS BLANKING

The ALD523D uses B1 and B2 as control-input pins for setting the “blanking” of the trailing digits of the display’s decimal digits. B1 and B2 switches can be applied in all

modes of operations with 4 combinations as shown in Table 6. Each logical state combination selects the numbers of digits to be displayed.

GROUP	J3			
FUNCTION	DIGIT BLANKING			
PIN	4	5		
SWITCHES	B1	B2	NUMBER OF DIGITS DISPLAYED	
LABEL/UNIT			7 CHARACTER UNIT	8 CHARACTER UNIT
LOGIC LEVEL	0	0	7-Digits (XXXXXXX)	6-Digits (XXXXXX)
	1	0	6-Digits (XXXXXX)	6-Digits (XXXXXX)
	0	1	5-Digits (XXXXX)	5-Digits (XXXXX)
	1	1	4-Digits (XXXX)	4-Digits (XXXX)

Table 6. Blanking switch combination for mode-A, mode-B, and mode-C.

When the label/unit “UNT1” or “UNT2” or “UNT3” parameter is set to 7-characters, at **B1=0** and **B2=0**, the ALD523D sets the display module to display a full 7-digit number. When the label/unit “UNT1” or “UNT2” or “UNT3” parameter is set to 8-characters, at **B1=0** and **B2=0**, the ALD523D sets the display module to display a full 6-digit number.

When **B1=1** and **B2=0**, the ALD523D instructs the display module to blank the last display digit, and the display now displays a 6-digit number. At **B1=0** and **B2=1**, the ALD523D blanks the last two digits of the display, and the display now show only a 5-digit number. Likewise at **B1=1** and **B2=1**, the ALD523D sets the display to show only the first 4 digits of the number.

SELECTING AND CONFIGURING MEASUREMENT SAMPLE AVERAGING

One of the effective techniques to minimize measurement noise and increase stability is to apply sampling to average a number of serial data samples. The ALD523D uses this technique to stabilize its serial data sample reading by filtering out noise associated with these samples. In general, the higher the number of serial data samples, the better the noise rejection, but it also takes longer for the display to respond to the input changes. A default recommended sample averaging of 8 offers a good tradeoff between conversion time and noise rejection.

The ALD523D utilizes DSA1 and DSA2 as control-input pins for selecting one of three different sets of data sampling, namely “AVG1”, “AVG2”, and “AVG3”. In all

Downloaded from Elcodis.com electronic components distributor

three modes of operations, DSA1 and DSA2 pins on the ALD523D function as data sample averaging selection switches. Four DSA1 and DSA2 switch combinations are described in Table 7. Each logical state combination selects a pre-defined averaging/sampling.

GROUP	J4		
FUNCTION	DATA SAMPLE AVERAGING		
PIN	6	7	
SWITCHES	DSA1	DSA2	AVERAGE
LOGIC LEVEL	0	0	No Average (1)
	1	0	AVG1 (1, 2, 4, 8, 16, 32, 64, 128)
	0	1	AVG2 (1, 2, 4, 8, 16, 32, 64, 128)
	1	1	AVG3 (1, 2, 4, 8, 16, 32, 64, 128)

Table 7. Averaging selection switch combination for mode-A, mode-B, and mode-C.

When **DSA1=0** and **DSA2=0**, the ALD523D is set to non-averaging mode. At **DSA1=1** and **DSA2=0**, the ALD523D utilizes the “AVG1” parameter set at address 02H of the EEPROM memory. At **DSA1=0** and **DSA2=1**, the ALD523D utilizes “AVG2” at address 03H of the EEPROM. At **DSA1=1** and **DSA2=1**, the ALD523D utilizes “AVG3” at address 04H of the EEPROM.

“AVG1”, “AVG2”, and “AVG3” parameters are 8-bit hexadecimal numbers at addresses 02H, 03H, and 04H of the first line of the .CDS file, respectively. Valid “AVG1”, “AVG2” and “AVG3” values are 1, 2, 4, 8, 16, 32, 64, and 128. These values correspond to the number of data samples averaged.

SELECTING AND CONFIGURING INTEGRATION TIME

When ALD500/ALD500R and ALD523D are used together as a chip set, an integration time needs to be selected for the system. For maximum 50/60-cycle line power noise rejection, Integration time t_{INT} must be picked as a multiple of the period of the power line frequency. For example, t_{INT} times of 16.667msec, 33.333msec, 50.000msec, 66.667msec, 100msec, 166.67msec, 200msec, and 300msec maximize 60Hz power line noise rejection. The t_{INT} times of 100msec, 200msec, and 300msec maximize 50Hz power line noise rejection.

In general, the longer the integration time, the better the noise rejection of the power line noise, but it also takes longer to complete a conversion cycle. Default recommended integration time of 100msec offers the best tradeoff of noise performance, conversion time and both 50/60-cycle power line noise rejection. The 100msec integration time also offers the benefit of being universally optimal for both 50 and 60 cycles power line noise rejection.

The ALD523D utilizes S1, S2, and S3 as control-input pins for selecting different integration times. In mode-A and mode-B, these switches set different integration time for different measurement needs based on different R_{int} and C_{int} time constant values (see ALD500/ALD500R data sheet for more information). However, these three pins are disabled in mode-C operation. The S1, S2 and S3 logical state combinations are listed in Table 8.

GROUP	J5						
FUNCTION	INTEGRATION TIME SELECTION						
PIN	3	27	28				
SWITCHES	S1	S2	S3	INTEGRATION TIME	APPRX. CONVERSION / SEC	NO. OF 60 Hz CYCLES	
LOGIC LEVEL	0	0	0	16.667 ms	10	1	
	0	0	1	33.333 ms	6.6	2	
	0	1	0	50.000 ms	5	3	
	0	1	1	66.667 ms	4	4	
	1	0	0	100.000 ms	3	6	
	1	0	1	166.667 ms	2	10	
	1	1	0	200.000 ms	1.5	12	
	1	1	1	300.000 ms	1	18	

Table 8. Integration time selection switch combination for mode-A and mode-B.

POWER UP AND POWER DOWN

Upon power up or power-on-reset, the ALD523D initializes all internal counters, registers, I/O ports, and the CDM. Then it reads the setting of the control-input pins, and sets up the mode of operation as programmed by instructions preset by the user in the EEPROM memory. When the mode of operation has not been preset, a message “PROGRAM MEMORY” is displayed on the CDM. Next, it checks the status of the $\overline{\text{PWRCS}}$ pin.

A logical “0” state on $\overline{\text{PWRCS}}$ pin powers up the ALD523D, and a logical “1” state on the $\overline{\text{PWRCS}}$ pin powers down the ALD523D as well as the ALD500R (mode-A) and blanks the CDM (in both mode-A and mode-B). The crystal oscillator circuit of the ALD523D is also stopped. To start and power up the ALD523D again, simply put a logical 0 state on the $\overline{\text{PWRCS}}$ pin. An external microprocessor can therefore utilize this pin to control the ALD523D power-on status. If power down feature is not used, then the $\overline{\text{PWRCS}}$ pin must be grounded through pull-down resistor to leave the ALD523D in continuously power-on mode.

REFERENCE CALIBRATION MODE

The ALD523D is designed to interface directly to the ALD500 or ALD500R integrating dual slope precision analog processors and work together as a chip set. One of the beneficial features of the ALD500R to the ALD500 is its precision internal voltage reference, which eliminates the need of introducing an external reference voltage to the conversion system, for equal or improved system performance along with reduced component count and cost.

The block diagram of the reference calibration mode is shown in figure 6. Unlike many external reference voltage circuits where reference voltage calibration is performed by tweaking trimmer pots, the internal reference voltage calibration is performed through the use of software calibration method, i.e. DVM523.EXE (see Calibrate Reference Voltage (#3 Key) section in the ALD523D Setup and Calibration Software User Guide).

Upon power up or during normal running condition, the ALD523D continuously checks the status of the control-input pins 18 and 12, namely $\overline{\text{DVCS}}$ and $\overline{\text{CAL}}$, respectively for entering setup and calibration modes. A logical “1” state on $\overline{\text{DVCS}}$ pin and a logical “0” on $\overline{\text{CAL}}$ pin instruct the ALD523D to enter the reference calibration mode.

Upon entering reference calibration mode, measurement data on the ALD523D is transmitted serially to the PC via $\overline{\text{SCLK}}$ and DATOUT pins. The ALD523D sets the $\overline{\text{SCLK}}$ pin to logic “0” state with the first bit of the serial data transmitted simultaneously via DATOUT pin. The PC reads the first bit on DATOUT and sends a serial clock pulse on the $\overline{\text{DVCS}}$ line as the acknowledge signal. This serial data read process continues for the rest of the 24 serial bits with alternatively sending serial clock pulses on every bit read, until $\overline{\text{SCLK}}$ is set to logic “1” state after 24 clock cycles.

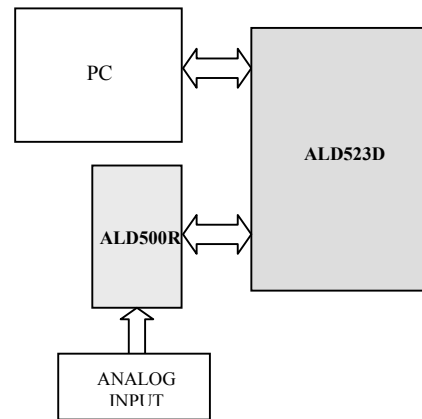

Figure 6. Reference calibration mode block diagram.

The 24-bit serial word corresponding to 24 serial clock pulses consists of a 23-bit binary word with MSB as the first bit and LSB the 23rd bit, followed by a sign bit as the last bit. The sign bit is set as logical “1” as a positive sign, and logical “0” as a negative sign.

Calibration mode can also be used as serial output port mode, where the output binary word can be clocked out by any PC, device or microprocessor having access to $\overline{\text{CAL}}$, $\overline{\text{SCLK}}$, DATOUT, and $\overline{\text{DVCS}}$ pins.

The detail calibration timing is shown in “ALD523D to PC Mode-A Reference Calibration Timing” section of this data sheet. When $\overline{\text{CAL}}$ pin is set to high at the end of calibration mode, the ALD523D returns to its normal continuous running mode.

EEPROM MEMORY

The ALD523D is organized to operate in conjunction with a 1K (128 bytes x 8 bits) bi-directional two-wire serial interface protocol EEPROM memory with page write (8 bytes) capability and has a typical 2 ms write cycle time for page write, i.e. the 24LC01B or compatible. The ALD523D stores its setup parameters and arithmetic parameters at specific memory address locations of the EEPROM. These parameters are transferred from DVM523.EXE PC software to the internal registers of the ALD523D via a standard PC parallel printer port, and are page written to the EEPROM from the ALD523D's internal registers via serial address/data I/O (SDA) and serial clock (SCL) lines. Once initiated, all data transfers between the PC to ALD523D and then to the EEPROM are performed on a handshake basis automatically. The setup parameters are predefined inside the .CDS file, where the arithmetic parameters are obtained from calibration process and/or conversion factor scaling.

DATA TRANSFER MODE FROM PC TO ALD523D

The setup parameters and arithmetic parameters of the ALD523D are stored at the specific memory address locations as depicted in Table 1 of the ALD523D Setup and Calibration Software User Guide, and uploaded to the EEPROM from PC via a parallel printer port (see Upload Page 1 To 6 (#4 Key) or Upload Page 1 To 13 (#5Key) To Memory section in the ALD523D Setup and Calibration Software User Guide on how to upload EEPROM via DVM523.EXE). The block diagram of the data transfer mode is shown in figure 7.

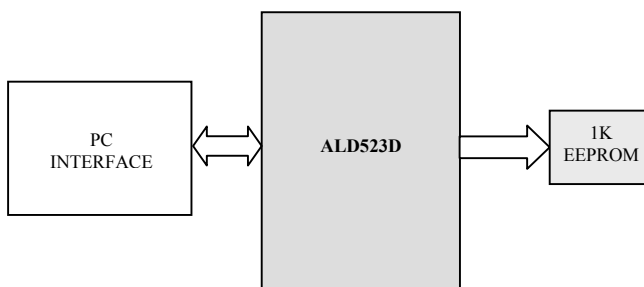

Figure 7. Data transfer mode block diagram.

Upon power up or during normal running condition, the ALD523D continuously checks the status of \overline{DVCS} and \overline{CAL} , respectively for the setup and calibration mode. A logical "0" state on \overline{DVCS} pin with a logical "0" on \overline{CAL} pin set by the PC put the ALD523D in the Data Transfer from PC mode.

In this mode, a message "UPLOAD MEMORY" is displayed on the Characters Display Module (CDM) to indicate the ALD523D is in data transfer mode. Parameters for uploading EEPROM are transferred from the PC to ALD523D serially via the \overline{SCLK} and DATIN pins, with 8 bytes of 8-bit data (total of 64 bits) as 1 page of data.

Initially, the bit and page counters within the ALD523D and the PC are set to 1, and the \overline{DVCS} pin is set to logic "0" state with the first bit of the serial data transmitted simultaneously via DATIN pin. The ALD523D reads the first bit on DATIN and sends a serial clock pulse on the \overline{SCLK} as the acknowledge signal. This serial data upload process continues for the rest of the 64 serial bits with alternatively receiving the \overline{DVCS} pulses from the PC and sending the corresponding serial clock pulses on every bit read, until the bit counter is set to 64 along with \overline{DVCS} set to logic "1" state, which then are in turn uploaded into the EEPROM automatically by the ALD523D, using the page write mode.

Then the page counter is advanced to the second page, and the PC puts out a second \overline{DVCS} logic "0" state, and begins the transfer of the next 8 bytes of 8-bit data. Through the repeated serial clock and data valid handshakes via \overline{DVCS} and \overline{SCLK} pins, either 6 pages or 13 pages of 8 bytes of 8-bit serial data are transmitted via DATIN pin into ALD523D's internal registers. This uploading process is fully automatic.

The 64-bit serial clock pulses transmit 64-bit binary data with bit 63 as the first bit and bit 0 as the last bit. The detailed timing is shown in "Data Transfer From PC" section of this data sheet. Once the PC sets the \overline{CAL} pin to logic "1" at the end of setup mode, the ALD523D returns to its normal running mode.

DEFAULT PULL-UP AND PULL-DOWN RESISTORS

Switches or jumpers can be used to interface the ALD523D control-input pins directly to the desired logic level, either V^+ or DGND, through 15-k Ω pull-up and 1-K Ω pull-down resistors. This method of connection is adopted as a default (standard) connection.

Figure 8 shows an example of standard connection where a switch SW or a jumper is used to pull the display set selection SEL1 control-input pin down to logic level “0” through a 1-k Ω pull-down resistor to GND with the switch SW closed. The SEL1 control-input pin is pulled up to logic level “1” through a 15-k Ω pull-up resistor to V^+ with the switch SW opened.

This method of connection allows both pull-up and pull-down resistors to be installed simultaneously. When switch SW is closed, the pin is normally at a logical “0” state, which sets SEL1=0. However, when ALD523D is transferring data to the CDM, the same pin changes function from SEL1 to D1, and the ALD523D output overrides both the pull-up and pull-down resistors. All the other multiplexed pins that interface to the CDM are multiplexed in the same way.

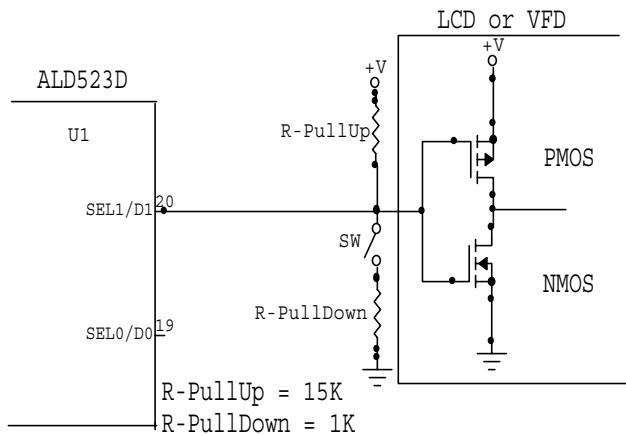

Figure 8. 15-k Ω pull-up or 1-k Ω pull-down resistor connection via SW switch.

CHARACTER DISPLAY MODULE

The ALD523D controller is designed for easy setting of industry standard Character Display Modules (CDM) such as 1 line by 16-character or 2-line by 16-character LCD or VFD display modules. These Character Display Modules consist of high contrast liquid crystal or vacuum fluorescence panels.

Each module contains an industry standard controller such as HD44780 or equivalent, and all necessary drivers. This industry standard controller is equipped with an internal Character Generator (CG ROM and CG RAM), Display Data (DD RAM), and Column Driver such as LC7930N or equivalent. ALD523D contains all the necessary display function instructions of the CDM to fully display all the characters on the display line(s), and to access all the available alphanumeric characters within the CG ROM.

Standard font version of CGROM, European font version of CGROM, or other custom versions of CGROM can be used with ALD523D. For more information, consult with the CDM manufacturer’s technical data.

ABSOLUTE MAXIMUM RATINGS³

Supply voltage, V^+	_____	+6.7V
Differential input voltage range	_____	-0.3 to V^+ + 0.3V
Power dissipation	_____	1.2 W
Operating temperature range	_____	0°C to +70°C
Storage temperature range	_____	-65°C to +150°C
Lead temperature, 10 seconds	_____	+260°C
Maximum allowable output current sunked by any I/O pin	_____	25mA
Maximum allowable output current sourced by any I/O pin	_____	25mA

DC OPERATING ELECTRICAL CHARACTERISTICS

$T_A = 0^\circ\text{C} - 70^\circ\text{C}$, $V^+ = +5\text{V}$, $f_{\text{XTL}} = 3.6864 \text{ MHz}$ unless otherwise specified

Parameter	Symbol	Min	Typ	Max	Unit	Test Conditions
Supply						
Operating Voltage Range	V^+	3	5	5.5	V	$V^+ = 3.5\text{V}$ $\overline{\text{PWRCS}} = +5\text{V}$, $V_{\text{IN}} = 0\text{V}$
Supply Current	I_{DD}		6.5	8.0	mA	
Supply Current	I_{DD}		2		mA	
Shutdown Mode Supply Current	I_{SDD}		3	10	μA	
Input Characteristics						
Low Input Voltage	V_{IL}	-0.3		1.0	V	
High Input Voltage	V_{IH}	3.5		5.3	V	
Input Leakage Current	I_{IL}	-1		2	μA	
Output Characteristics						
Low Output Voltage	V_{OL}		0.2	0.4	V	$I_{\text{out}} = 4 \text{ mA}$
High Output Voltage	V_{OH}	4.6	4.8		V	$I_{\text{out}} = -2 \text{ mA}$

TIMING CHARACTERISTICS

$T_A = 0^\circ\text{C} - 70^\circ\text{C}$, $V^+ = +5\text{V}$, $f_{\text{XTL}} = 3.6864 \text{ MHz}$, internal system clock = $f_{\text{XTL}}/4$ unless otherwise specified

Parameter	Symbol	Min	Typ	Max	Unit	Test Conditions
Display Only (Mode-C) Timing						
DATIN Setup Time	t_{DS}	3.7			μs	
Serial Clock Low Time	t_{SCL}	16.2			μs	
Serial Clock High Time	t_{SCH}	67.6			μs	
DVCS to DATIN Valid Time	t_{DIV}	67.62			μs	
Serial Clock to DVCS High Time	t_{DVCSH}			22.22	μs	
Power Timing						
Power-On-Reset Time	t_{POR}		2		sec	
Data Transfer From PC Timing⁴						
Calibration to Data Valid Time	t_{CALDV}			1.9	μs	
Serial Clock High Time	t_{SCLKH}			67	μs	
Serial Clock Low Time	t_{SCLKL}	10			μs	
Data Valid to Serial Clock Delay Time	t_{DSdelay}	0.271		500,000	μs	
Serial Clock to Data Valid High Time	t_{SCDVH}	0		DC	ns	
Serial Clock to Data Valid Low Time	t_{SCDVL}	0		DC	ns	
DATIN Setup Time	t_{DS}	2.4			μs	
Data Valid High Time	t_{DVH}	10			μs	
Serial Clock to Calibration Time	t_{SCCAL}	0		8	ms	
Reference Calibration Timing						
Auto Zero Time	t_{AZ}		t_{INT}		ms	
Integration Time ^{1,2}	t_{INT}	16.667		300	ms	
Integrator Zero Time	t_{INTZ}		2		ms	
Calibration Setup Time	t_{CS}	1.1			μs	
Calibration Delay Time ⁵	t_{CD}	1			Conv. Cycle	
DATOUT Valid Setup Time	t_{DVS}	18			μs	
DATOUT Not Valid Time	t_{DNV}		15		μs	
DATOUT Valid Time	t_{DV}	11			μs	
DATOUT Valid Time Out Time	t_{TO}			5.5	ms	
DATOUT Out Time	t_{DATOUT}			500	ns	
Input / Output Characteristic Timing						
Input Interrupt Low Time	t_{IL}	70			ns	$\overline{\text{CAL}}$, $\overline{\text{PWRCs}}$, COUT , $\overline{\text{DVCS}}$
Rise/Fall Times (CL = 10pF)	t_{R} , t_{F}		25	125	ns	
Oscillator (OSC_{IN}, OSC_{OUT})						
Crystal Frequency	f_{XTL}		3.6864	8	MHz	
External Frequency (OSC _{IN})	f_{OSC}			8	MHz	Rise time/Fall time $\leq 15 \text{ ns}$

¹ Apply only for calibrated reference (mode-A) and ratiometric (mode-B) operations.

² Extendible from S1, S2, and S3 hardware switches through "SETF" parameter in the .CDS file. Lower integration time than the minimum allows more conversion cycles per second at reduced count resolution. Higher integration time increases count resolution, but requires increased capacitor value and lowered number of conversion cycles per second. De-integration time depends on selection of full scale input range, integration capacitor value and voltage reference.

³ ESD Sensitive Device. Stresses above those listed under Absolute Maximum Ratings may cause permanent damage to device, and may affect device reliability and performance.

⁴ PC to ALD523D handshake using page write mode.

⁵ Calibration delay time (t_{CD}) may be as short as 7 μs , if start of auto zero phase cycle time could be determined. For asynchronous operation, t_{CD} must be for a minimum of one complete conversion cycle to assure synchronization to start of auto zero phase cycle time.

DISPLAY ONLY (MODE-C) TIMING

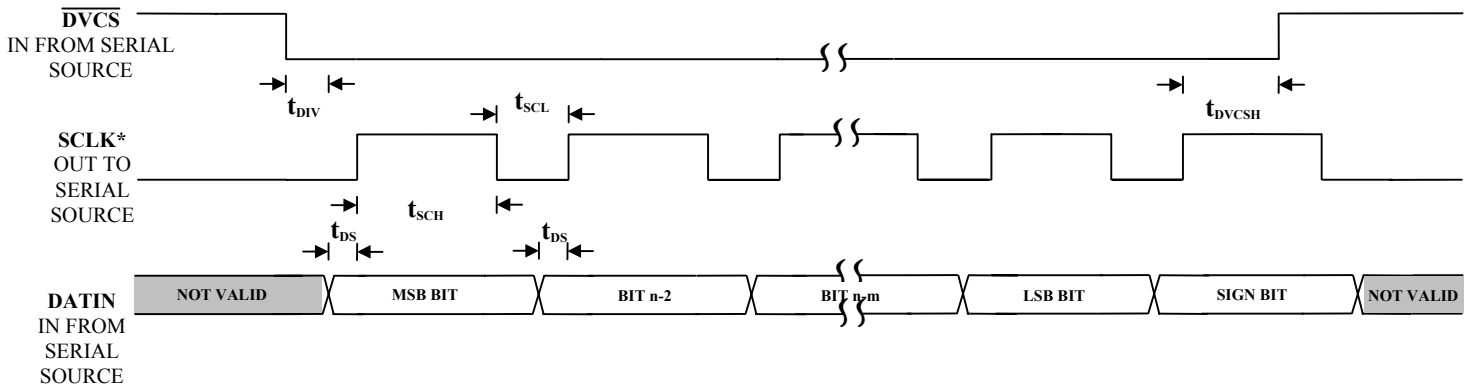

*Note: Default mode is SCLK, which can be inverted to produce $\overline{\text{SCLK}}$ by software setup.

DATA TRANSFER FROM PC TIMING

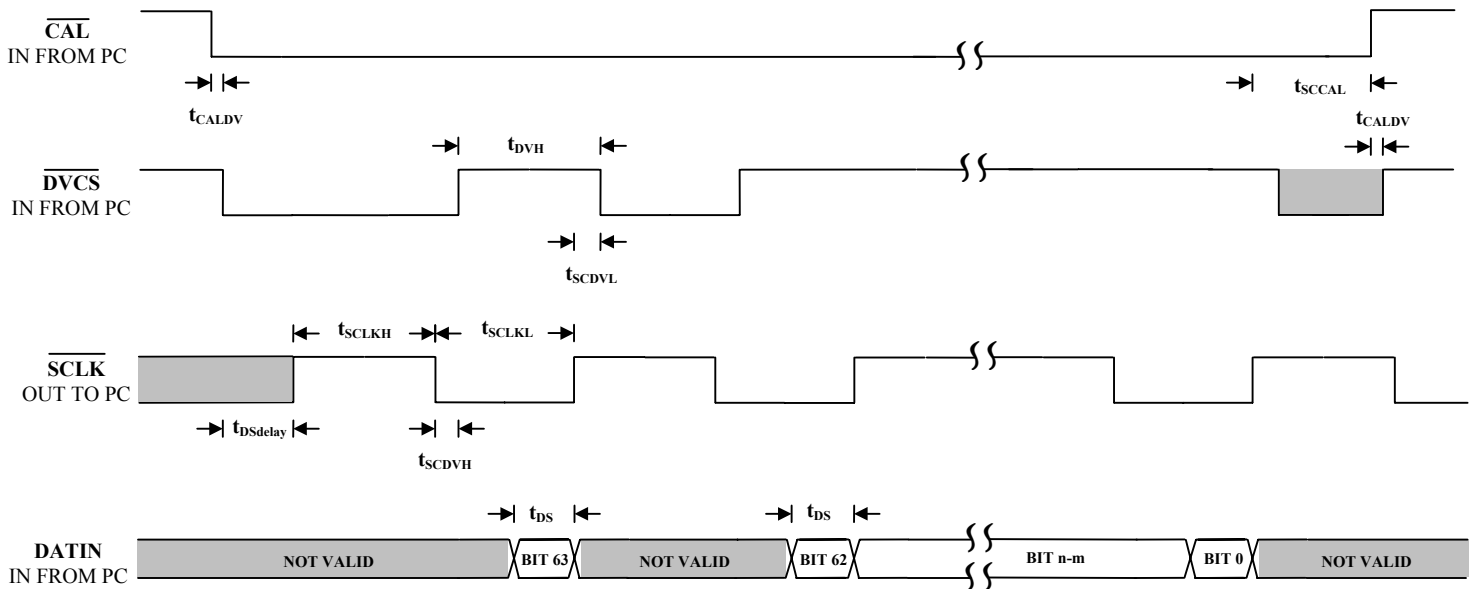

*n is the number of serial data bits, and m is the integer of 1, 2, ..., n.

© 2001 Advanced Linear Devices, Inc., 415 Tasman Drive, Sunnyvale, California 94089-1706, Tel: (408) 747-1155, Fax: (408) 747-1286

ALD523D

12/01

<http://www.aldinc.com>

17 of 20

ALD523D TO PC MODE-A REFERENCE CALIBRATION TIMING

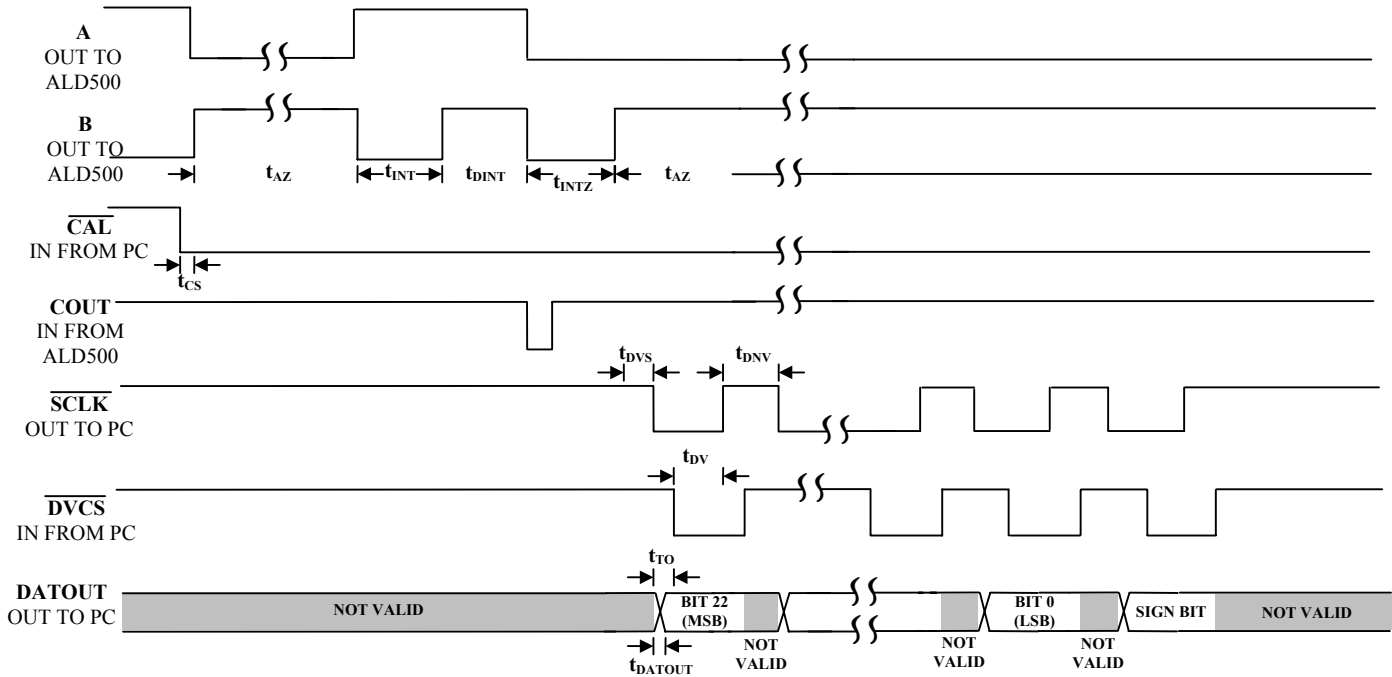

EXPANDED VIEW

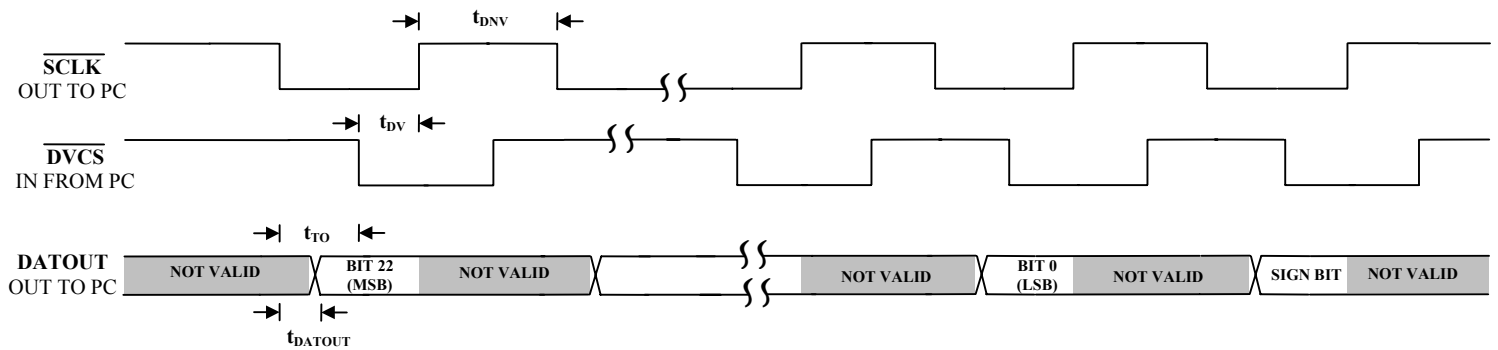

ALD523D PIN IDENTIFICATION FOR CALIBRATED REFERENCE MODE (MODE-A)

PIN #	SYMBOL	FUNCTION	SIGNAL PROPAGATION
1	COUT	COMPARATOR OUTPUT	INPUT
2	SDA	MEMORY SERIAL ADDRESS/DATA	INPUT/OUTPUT
3	S1, SCL	INTEGRATION TIME SWITCH, MEMORY SERIAL CLOCK	INPUT/ OUTPUT
4	B1, D4	BLANK SWITCH, DISPLAY DATA BIT	INPUT/OUTPUT
5	B2, D5	BLANK SWITCH, DISPLAY DATA BIT	INPUT/OUTPUT
6	DSA1, D6	AVERAGING SWITCH, DISPLAY DATA BIT	INPUT/OUTPUT
7	DSA2, D7	AVERAGING SWITCH, DISPLAY DATA BIT	INPUT/OUTPUT
8	V ⁺	POWER SUPPLY	
9	XTAL2	CRYSTAL OSCILLATOR	OUTPUT
10	XTAL1	CRYSTAL OSCILLATOR	INPUT
11	COUT	COMPARATOR OUTPUT	INPUT INTERRUPT
12	$\overline{\text{CAL}}$	CALIBRATION SIGNAL	INPUT
13	$\overline{\text{PWRCS}}$	POWER UP CHIP SELECT	INPUT
14	CS	CHIP SELECT	OUTPUT
15	B	A/D INPUT	OUTPUT
16	WP	MEMORY WRITE PROTECT	OUTPUT
17	A	A/D INPUT	OUTPUT
18	$\overline{\text{DVCS}}$	DATA VALID CHIP SELECT	INPUT
19	SEL0, D0	MODE SWITCH, DISPLAY DATA BIT	INPUT/OUTPUT
20	SEL1, D1	MODE SWITCH, DISPLAY DATA BIT	INPUT/OUTPUT
21	DEC1, D2	DECIMAL POSITION SWITCH, DISPLAY DATA BIT	INPUT/OUTPUT
22	DGND	DIGITAL GROUND	
23	DEC2, D3	DECIMAL POSITION SWITCH, DISPLAY DATA BIT	INPUT/OUTPUT
24	DATIN	DATA IN	INPUT
25	$\overline{\text{SCLK}}$	SERIAL CLOCK	OUTPUT
26	DATOUT	DATA OUT	OUTPUT
27	S2, EN	INTEGRATION TIME SWITCH, DISPLAY ENABLE	INPUT/OUTPUT
28	S3, RS	INTEGRATION TIME SWITCH, DISPLAY REGISTER SELECT	INPUT/OUTPUT

ALD523D PIN IDENTIFICATION FOR RATIOMETRIC MODE (MODE-B)

PIN #	SYMBOL	FUNCTION	SIGNAL PROPAGATION
1	COUT	COMPARATOR OUTPUT	INPUT
2	SDA	MEMORY SERIAL ADDRESS/DATA	INPUT/OUTPUT
3	S1, SCL	INTEGRATION TIME SWITCH, MEMORY SERIAL CLOCK	INPUT/ OUTPUT
4	B1, D4	BLANK SWITCH, DISPLAY DATA BIT	INPUT/OUTPUT
5	B2, D5	BLANK SWITCH, DISPLAY DATA BIT	INPUT/OUTPUT
6	DSA1, D6	AVERAGING SWITCH, DISPLAY DATA BIT	INPUT/OUTPUT
7	DSA2, D7	AVERAGING SWITCH, DISPLAY DATA BIT	INPUT/OUTPUT
8	V ⁺	POWER SUPPLY	
9	XTAL2	CRYSTAL OSCILLATOR	OUTPUT
10	XTAL1	CRYSTAL OSCILLATOR	INPUT
11	COUT	COMPARATOR OUTPUT	INPUT INTERRUPT
12	$\overline{\text{CAL}}$	CALIBRATION SIGNAL	INPUT
13	$\overline{\text{PWRCS}}$	POWER UP CHIP SELECT	INPUT
14	CS	CHIP SELECT	OUTPUT
15	B	A/D INPUT	OUTPUT
16	WP	MEMORY WRITE PROTECT	OUTPUT
17	A	A/D INPUT	OUTPUT
18	$\overline{\text{DVCS}}$	DATA VALID CHIP SELECT	INPUT
19	SEL0, D0	MODE SWITCH, DISPLAY DATA BIT	INPUT/OUTPUT
20	SEL1, D1	MODE SWITCH, DISPLAY DATA BIT	INPUT/OUTPUT
21	M, D2	ZERO MASTER SWITCH, DISPLAY DATA BIT	INPUT/OUTPUT
22	DGND	DIGITAL GROUND	
23	Z, D3	ZERO SWITCH, DISPLAY DATA BIT	INPUT/OUTPUT
24	DATIN	DATA IN	INPUT
25	$\overline{\text{SCLK}}$	SERIAL CLOCK	OUTPUT
26	DATOUT	DATA OUT	OUTPUT
27	S2, EN	INTEGRATION TIME SWITCH, DISPLAY ENABLE	INPUT/OUTPUT
28	S3, RS	INTEGRATION TIME SWITCH, DISPLAY REGISTER SELECT	INPUT/OUTPUT

ALD523D PIN IDENTIFICATION FOR DISPLAY ONLY MODE (MODE-C)

PIN #	SYMBOL	FUNCTION	SIGNAL PROPAGATION
1	-	-	-
2	SDA	MEMORY SERIAL ADDRESS/DATA	INPUT/OUTPUT
3	SCL	MEMORY SERIAL CLOCK	OUTPUT
4	B1, D4	BLANK SWITCH, DISPLAY DATA BIT	INPUT/OUTPUT
5	B2, D5	BLANK SWITCH, DISPLAY DATA BIT	INPUT/OUTPUT
6	DSA1, D6	AVERAGING SWITCH, DISPLAY DATA BIT	INPUT/OUTPUT
7	DSA2, D7	AVERAGING SWITCH, DISPLAY DATA BIT	INPUT/OUTPUT
8	V ⁺	POWER SUPPLY	-
9	XTAL2	CRYSTAL OSCILLATOR	OUTPUT
10	XTAL1	CRYSTAL OSCILLATOR	INPUT
11	-	-	-
12	$\overline{\text{CAL}}$	CALIBRATION SIGNAL	INPUT
13	$\overline{\text{PWRCS}}$	POWER UP CHIP SELECT	INPUT
14	-	-	-
15	-	-	-
16	WP	MEMORY WRITE PROTECT	OUTPUT
17	-	-	-
18	$\overline{\text{DVCS}}$	DATA VALID CHIP SELECT	INPUT
19	SEL0, D0	MODE SWITCH, DISPLAY DATA BIT	INPUT/OUTPUT
20	SEL1, D1	MODE SWITCH, DISPLAY DATA BIT	INPUT/OUTPUT
21	DEC1, D2	DECIMAL POSITION SWITCH, DISPLAY DATA BIT	INPUT/OUTPUT
22	DGND	DIGITAL GROUND	-
23	DEC2, D3	DECIMAL POSITION SWITCH, DISPLAY DATA BIT	INPUT/OUTPUT
24	DATIN	DATA IN	INPUT
25	SCLK	SERIAL CLOCK	OUTPUT
26	DATOUT	DATA OUT	OUTPUT
27	EN	DISPLAY ENABLE	OUTPUT
28	RS	DISPLAY REGISTER SELECT	OUTPUT