

# LMS8117A

## 1A Low-Dropout Linear Regulator

### General Description

The LMS8117A is a series of low dropout voltage regulators with a dropout of 1.2V at 1A of load current. It has the same pin-out as National Semiconductor's industry standard LM317.

The LMS8117A is available in an adjustable version, which can set the output voltage from 1.25V to 13.8V with only two external resistors. In addition, it is also available in two fixed voltages, 1.8V and 3.3V.

The LMS8117A offers current limiting and thermal shutdown. Its circuit includes a zener trimmed bandgap reference to assure output voltage accuracy to within  $\pm 1\%$ .

The LMS8117A series is available in SOT-223 and TO-252 D-PAK packages. A minimum of 10 $\mu$ F tantalum capacitor is required at the output to improve the transient response and stability.

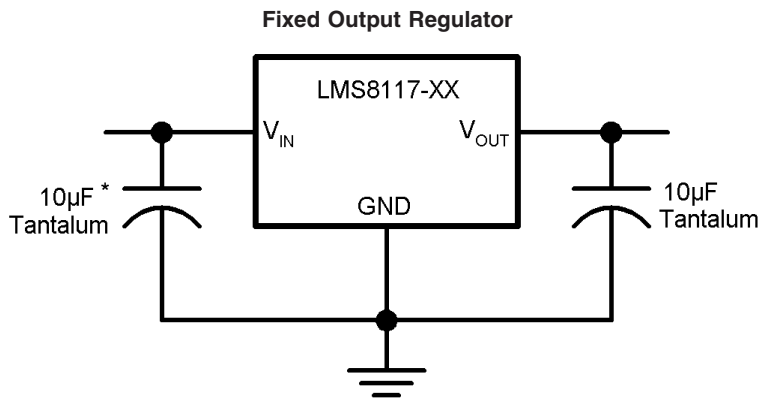
### Features

- Available in 1.8V, 3.3V, and Adjustable Versions
- Space Saving SOT-223 and TO-252 Packages
- Current Limiting and Thermal Protection
- Output Current 1A
- Temperature Range 0°C to 125°C
- Line Regulation 0.2% (Max)
- Load Regulation 0.4% (Max)

### Applications

- Post Regulator for Switching DC/DC Converter
- High Efficiency Linear Regulators
- Battery Charger
- Battery Powered Instrumentation

### Typical Application



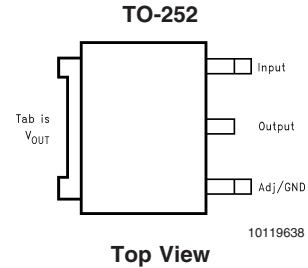
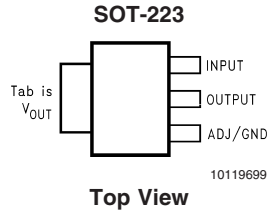
\*Required if the regulator is located far from the power supply filter

10119628

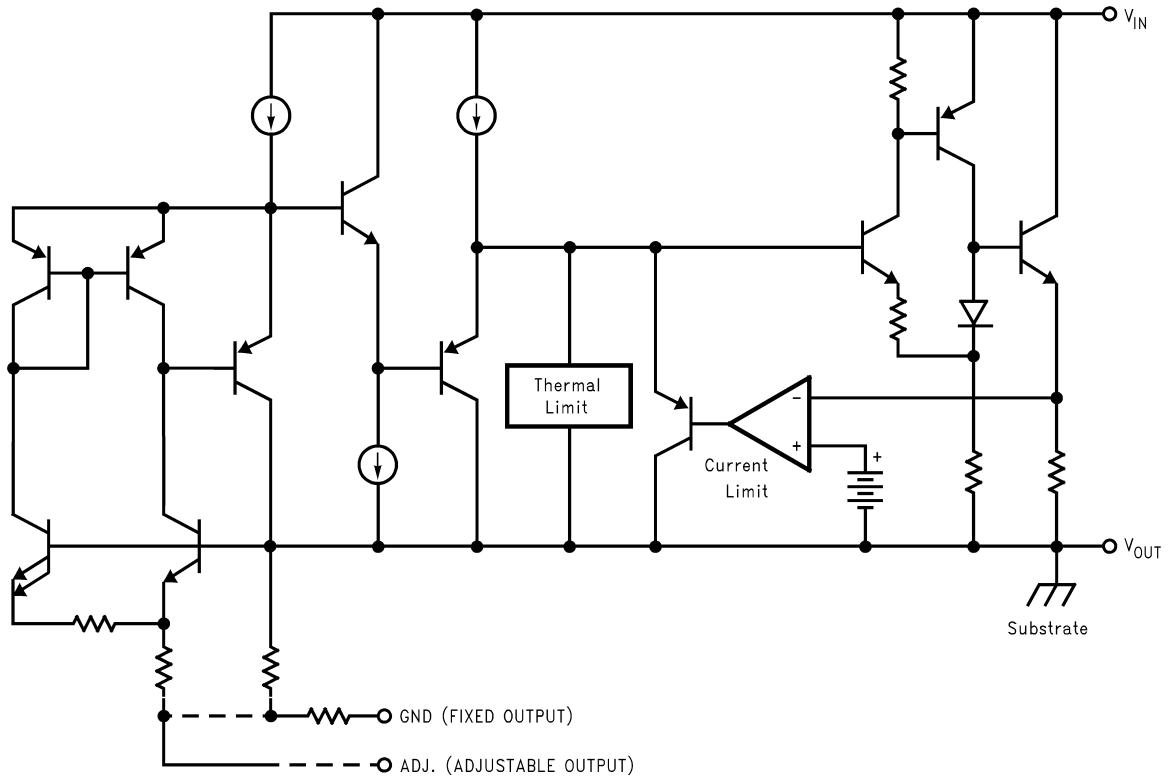
## Ordering Information

Package	Temperature Range ( $T_J$ )	Packaging Marking	Transport Media	NSC Drawing
	0°C to +125°C			
3-lead SOT-223	LMS8117AMP-ADJ	LS0A	1k Tape and Reel	MP04A
	LMS8117AMPX-ADJ	LS0A	2k Tape and Reel	
	LMS8117AMP-1.8	LS00	1k Tape and Reel	
	LMS8117AMPX-1.8	LS00	2k Tape and Reel	
	LMS8117AMP-3.3	LS01	1k Tape and Reel	
	LMS8117AMPX-3.3	LS01	2k Tape and Reel	
3-lead TO-252	LMS8117ADT-ADJ	LMS8117ADT-ADJ	Rails	TD03B
	LMS8117ADTX-ADJ	LMS8117ADT-ADJ	2.5k Tape and Reel	
	LMS8117ADT-1.8	LMS8117ADT-1.8	Rails	
	LMS8117ADTX-1.8	LMS8117ADT-1.8	2.5k Tape and Reel	
	LMS8117ADT-3.3	LMS8117ADT-3.3	Rails	
	LMS8117ADTX-3.3	LMS8117ADT-3.3	2.5k Tape and Reel	

## Connection Diagrams



## Block Diagram



**Absolute Maximum Ratings** (Note 1)

If Military/Aerospace specified devices are required, please contact the National Semiconductor Sales Office/Distributors for availability and specifications.

Maximum Input Voltage ( $V_{IN}$ to GND)	
LMS8117A-ADJ, LMS8117A-1.8, LMS8117A-3.3	20V
Power Dissipation (Note 2)	Internally Limited
Junction Temperature ( $T_J$ ) (Note 2)	150°C
Storage Temperature Range	-65°C to 150°C

## Soldering Information

Infrared (20 sec)	235°C
ESD Tolerance (Note 3)	2000V

**Operating Ratings** (Note 1)

Input Voltage ( $V_{IN}$ to GND)	
LMS8117A-ADJ, LMS8117A-1.8, LMS8117A-3.3	15V
Junction Temperature Range ( $T_J$ )(Note 2)	0°C to 125°C

**Electrical Characteristics**

Typicals and limits appearing in normal type apply for  $T_J = 25^\circ\text{C}$ . Limits appearing in **Boldface** type apply over the entire junction temperature range for operation, 0°C to 125°C.

Symbol	Parameter	Conditions	Min (Note 5)	Typ (Note 4)	Max (Note 5)	Units	
$V_{REF}$	Reference Voltage	LMS8117A-ADJ					
		$I_{OUT} = 10\text{mA}$ , $V_{IN}-V_{OUT} = 2\text{V}$ , $T_J = 25^\circ\text{C}$ $10\text{mA} \leq I_{OUT} \leq 1\text{A}$ , $1.4\text{V} \leq V_{IN}-V_{OUT} \leq 10\text{V}$	1.238	1.250	1.262	V	
$V_{OUT}$	Output Voltage	LMS8117A-1.8					
		$I_{OUT} = 10\text{mA}$ , $V_{IN} = 3.8\text{V}$ , $T_J = 25^\circ\text{C}$ $0 \leq I_{OUT} \leq 1\text{A}$ , $3.2\text{V} \leq V_{IN} \leq 10\text{V}$	1.782	1.800	1.818	V	
		LMS8117A-3.3					
		$I_{OUT} = 10\text{mA}$ , $V_{IN} = 5\text{V}$ , $T_J = 25^\circ\text{C}$ $0 \leq I_{OUT} \leq 1\text{A}$ , $4.75\text{V} \leq V_{IN} \leq 10\text{V}$	3.267	3.300	3.333	V	
$\Delta V_{OUT}$	Line Regulation (Note 6)	LMS8117A-ADJ					
		$I_{OUT} = 10\text{mA}$ , $1.5\text{V} \leq V_{IN}-V_{OUT} \leq 13.75\text{V}$		0.035	<b>0.2</b>	%	
		LMS8117A-1.8			1	<b>6</b>	mV
$\Delta V_{OUT}$	Load Regulation (Note 6)	LMS8117A-1.8					
		$I_{OUT} = 0\text{mA}$ , $3.2\text{V} \leq V_{IN} \leq 10\text{V}$					
		LMS8117A-3.3					
$\Delta V_{OUT}$	Load Regulation (Note 6)	LMS8117A-3.3					
		$I_{OUT} = 0\text{mA}$ , $4.75\text{V} \leq V_{IN} \leq 15\text{V}$		1	<b>6</b>	mV	
		LMS8117A-ADJ					
$V_{IN}-V_{OUT}$	Dropout Voltage (Note 7)	$V_{IN}-V_{OUT} = 3\text{V}$ , $10\text{mA} \leq I_{OUT} \leq 1\text{A}$		0.2	<b>0.4</b>	%	
		LMS8117A-1.8					
		$V_{IN} = 3.2\text{V}$ , $0 \leq I_{OUT} \leq 1\text{A}$		1	<b>10</b>	mV	
$V_{IN}-V_{OUT}$	Dropout Voltage (Note 7)	LMS8117A-3.3					
		$V_{IN} = 4.75\text{V}$ , $0 \leq I_{OUT} \leq 1\text{A}$		1	<b>10</b>	mV	
		$I_{OUT} = 100\text{mA}$			1.1	<b>1.15</b>	V
$I_{LIMIT}$	Current Limit	$I_{OUT} = 500\text{mA}$			1.15	<b>1.2</b>	V
		$I_{OUT} = 1\text{A}$			1.2	<b>1.25</b>	V
		$V_{IN}-V_{OUT} = 5\text{V}$ , $T_J = 25^\circ\text{C}$	1.0	1.4	1.9	A	
	Minimum Load Current (Note 8)	LMS8117A-ADJ					
		$V_{IN} = 15\text{V}$		1.7	<b>5</b>	mA	
	Quiescent Current	LMS8117A-1.8					
		$V_{IN} \leq 15\text{V}$		5	<b>10</b>	mA	
	Thermal Regulation	LMS8117A-3.3					
		$V_{IN} \leq 15\text{V}$		5	<b>10</b>	mA	
	Thermal Regulation	$T_A = 25^\circ\text{C}$ , 30ms Pulse		0.01	0.1	%/W	
	Ripple Regulation	$f_{RIPPLE} = 120\text{Hz}$ , $V_{IN}-V_{OUT} = 3\text{V}$ $V_{RIPPLE} = 1V_{PP}$	<b>60</b>	75		dB	
	Adjust Pin Current			60	<b>120</b>	$\mu\text{A}$	
	Adjust Pin Current Change	$10\text{mA} \leq I_{OUT} \leq 1\text{A}$ , $1.4\text{V} \leq V_{IN}-V_{OUT} \leq 10\text{V}$		0.2	<b>5</b>	$\mu\text{A}$	

## Electrical Characteristics (Continued)

Typicals and limits appearing in normal type apply for  $T_J = 25^\circ\text{C}$ . Limits appearing in **Boldface** type apply over the entire junction temperature range for operation,  $0^\circ\text{C}$  to  $125^\circ\text{C}$ .

Symbol	Parameter	Conditions	Min (Note 5)	Typ (Note 4)	Max (Note 5)	Units
	Temperature Stability			0.5		%
	Long Term Stability	$T_A = 125^\circ\text{C}$ , 1000Hrs		0.3		%
	RMS Output Noise	(% of $V_{OUT}$ ), $10\text{Hz} \leq f \leq 10\text{kHz}$		0.003		%
	Thermal Resistance Junction-to-Case	3-Lead SOT-223 3-Lead TO-252		15.0 10		$^\circ\text{C}/\text{W}$ $^\circ\text{C}/\text{W}$
	Thermal Resistance Junction-to-Ambient (No heat sink; No air flow)	3-Lead SOT-223 3-Lead TO-252 (Note 9)		136 92		$^\circ\text{C}/\text{W}$ $^\circ\text{C}/\text{W}$

**Note 1:** Absolute Maximum Ratings indicate limits beyond which damage to the device may occur. Operating Ratings indicate conditions for which the device is intended to be functional, but specific performance is not guaranteed. For guaranteed specifications and the test conditions, see the Electrical Characteristics.

**Note 2:** The maximum power dissipation is a function of  $T_{J(MAX)}$ ,  $\theta_{JA}$ , and  $T_A$ . The maximum allowable power dissipation at any ambient temperature is  $P_D = (T_{J(MAX)} - T_A) / \theta_{JA}$ . All numbers apply for packages soldered directly into a PC board.

**Note 3:** For testing purposes, ESD was applied using human body model,  $1.5\text{k}\Omega$  in series with  $100\text{pF}$ .

**Note 4:** Typical Values represent the most likely parametric norm.

**Note 5:** All limits are guaranteed by testing or statistical analysis.

**Note 6:** Load and line regulation are measured at constant junction room temperature.

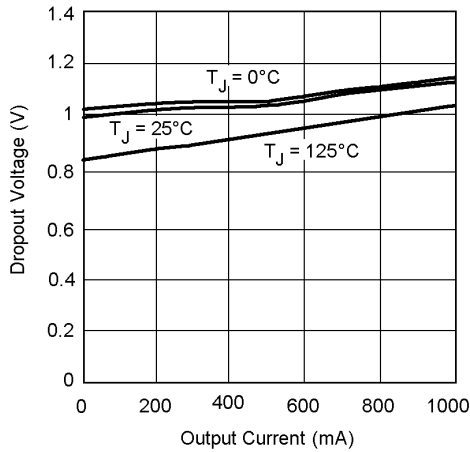
**Note 7:** The dropout voltage is the input/output differential at which the circuit ceases to regulate against further reduction in input voltage. It is measured when the output voltage has dropped  $100\text{mV}$  from the nominal value obtained at  $V_{IN} = V_{OUT} + 1.5\text{V}$ .

**Note 8:** The minimum output current required to maintain regulation.

**Note 9:** Minimum pad size of  $0.038\text{in}^2$

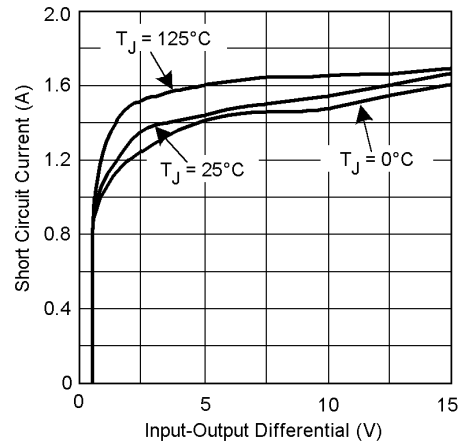
# Typical Performance Characteristics

**Dropout Voltage ( $V_{IN}-V_{OUT}$ )**



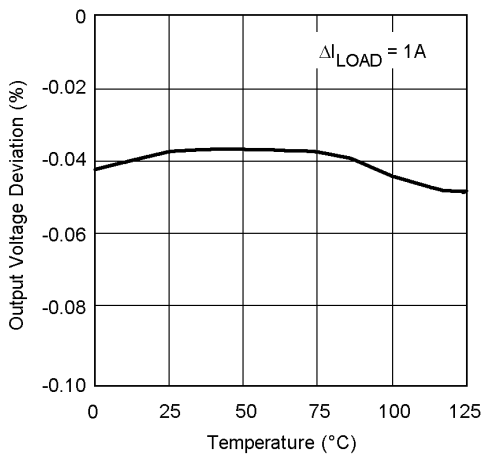
10119622

**Short-Circuit Current**



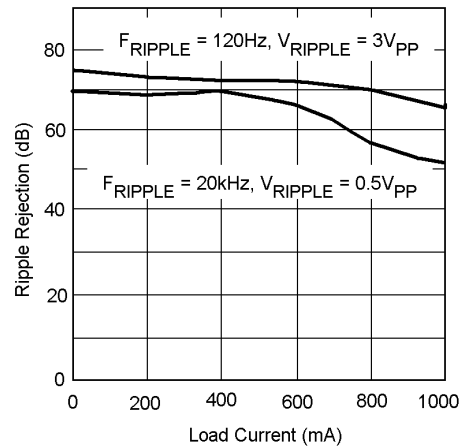
10119623

**Load Regulation**



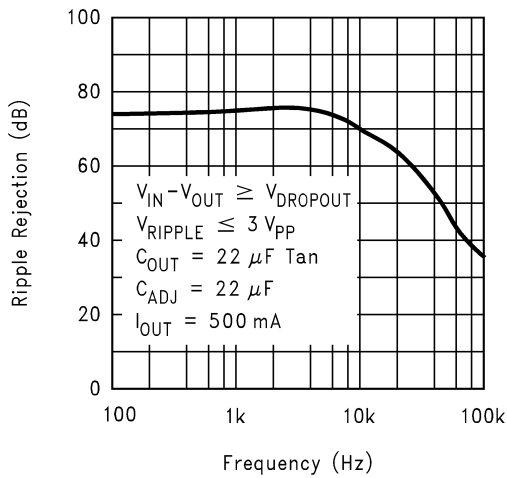
10119624

**LMS8117A-ADJ Ripple Rejection vs. Current**



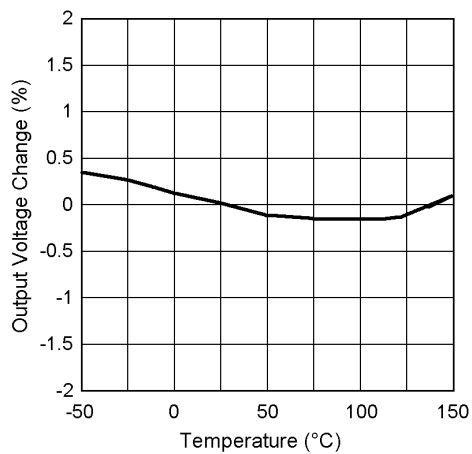
10119606

**LMS8117A-ADJ Ripple Rejection**



10119607

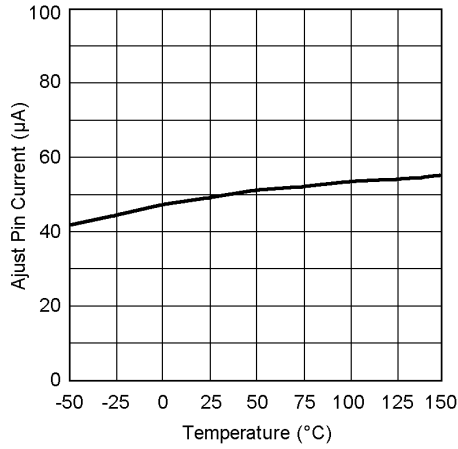
**Temperature Stability**



10119625

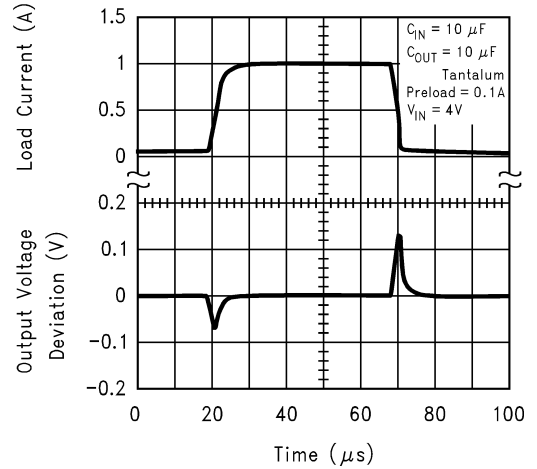
# Typical Performance Characteristics (Continued)

**Adjust Pin Current**



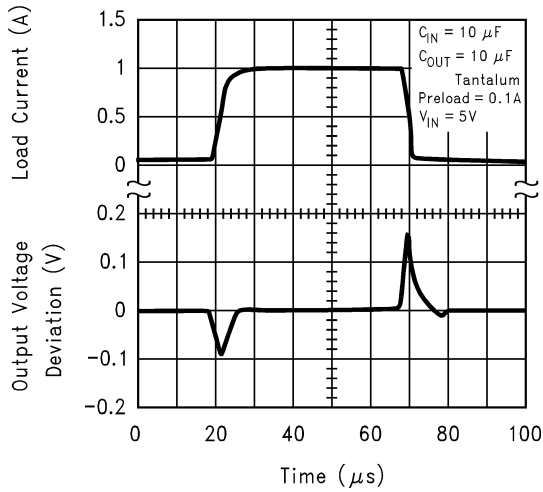
10119626

**LMS8117A-1.8 Load Transient Response**



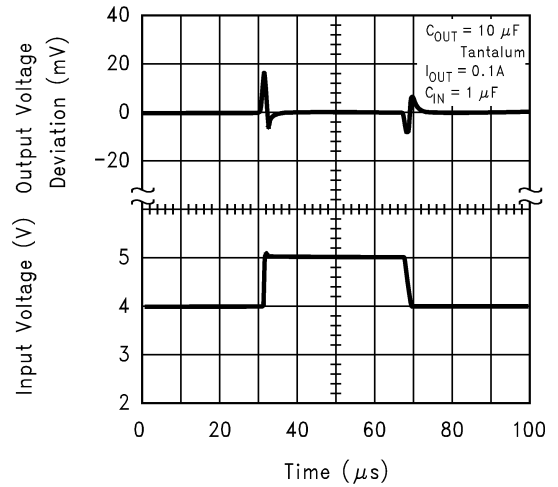
10119608

**LMS8117A-3.3 Load Transient Response**



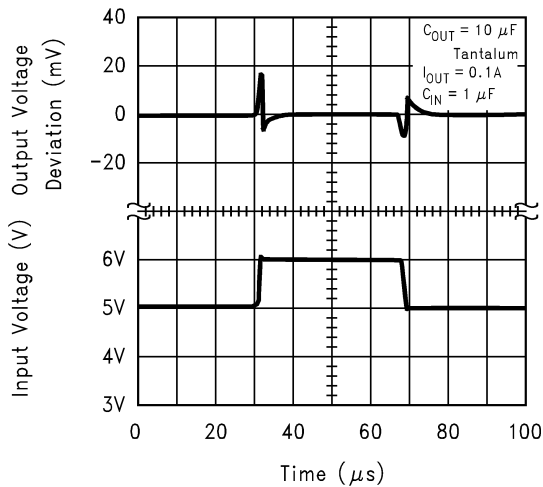
10119609

**LMS8117A-1.8 Line Transient Response**



10119610

**LMS8117A-3.3 Line Transient Response**



10119611

## Application Note

### 1.0 EXTERNAL CAPACITORS/STABILITY

#### 1.1 Input Bypass Capacitor

An input capacitor is recommended. A 10 $\mu$ F tantalum on the input is a suitable input bypassing for almost all applications.

#### 1.2 Adjust Terminal Bypass Capacitor

The adjust terminal can be bypassed to ground with a bypass capacitor ( $C_{ADJ}$ ) to improve ripple rejection. This bypass capacitor prevents ripple from being amplified as the output voltage is increased. At any ripple frequency, the impedance of the  $C_{ADJ}$  should be less than  $R1$  to prevent the ripple from being amplified:

$$1/(2\pi * f_{RIPPLE} * C_{ADJ}) < R1$$

The  $R1$  is the resistor between the output and the adjust pin. Its value is normally in the range of 100-200 $\Omega$ . For example, with  $R1 = 124\Omega$  and  $f_{RIPPLE} = 120\text{Hz}$ , the  $C_{ADJ}$  should be  $> 11\mu\text{F}$ .

#### 1.3 Output Capacitor

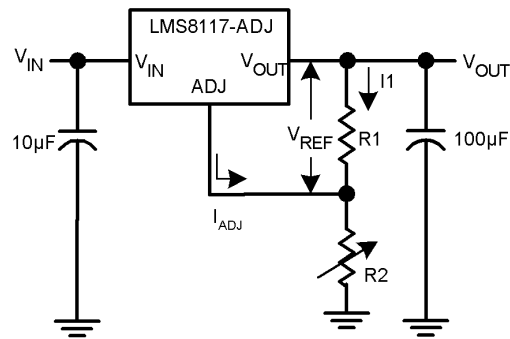
The output capacitor is critical in maintaining regulator stability, and must meet the required conditions for both minimum amount of capacitance and ESR (Equivalent Series Resistance). The minimum output capacitance required by the LMS8117A is 10 $\mu$ F, if a tantalum capacitor is used. Any increase of the output capacitance will merely improve the loop stability and transient response. The ESR of the output capacitor should be greater than 0.5 $\Omega$  and less than 5 $\Omega$ . In the case of the adjustable regulator, when the  $C_{ADJ}$  is used, a larger output capacitance (22 $\mu$ F tantalum) is required.

### 2.0 OUTPUT VOLTAGE

The LMS8117A adjustable version develops a 1.25V reference voltage,  $V_{REF}$ , between the output and the adjust terminal. As shown in *Figure 1*, this voltage is applied across resistor  $R1$  to generate a constant current  $I1$ . The current  $I_{ADJ}$  from the adjust terminal could introduce error to the output. But since it is very small (60 $\mu$ A) compared with the  $I1$  and very constant with line and load changes, the error can be ignored. The constant current  $I1$  then flows through the output set resistor  $R2$  and sets the output voltage to the desired level.

For fixed voltage devices,  $R1$  and  $R2$  are integrated inside the devices.

For fixed voltage devices,  $R1$  and  $R2$  are integrated inside the devices.



$$V_{OUT} = V_{REF} (1 + R2/R1) + I_{ADJ} R2$$

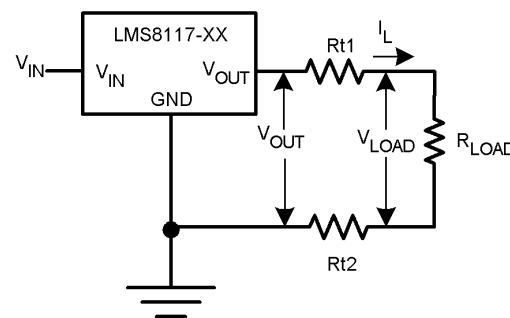
10119617

FIGURE 1. Basic Adjustable Regulator

### 3.0 LOAD REGULATION

The LMS8117A regulates the voltage that appears between its output and ground pins, or between its output and adjust pins. In some cases, line resistances can introduce errors to the voltage across the load. To obtain the best load regulation, a few precautions are needed.

*Figure 2*, shows a typical application using a fixed output regulator. The  $Rt1$  and  $Rt2$  are the line resistances. It is obvious that the  $V_{LOAD}$  is less than the  $V_{OUT}$  by the sum of the voltage drops along the line resistances. In this case, the load regulation seen at the  $R_{LOAD}$  would be degraded from the data sheet specification. To improve this, the load should be tied directly to the output terminal on the positive side and directly tied to the ground terminal on the negative side.



$$V_{LOAD} = V_{OUT} - I_L (Rt1 + Rt2)$$

10119618

FIGURE 2. Typical Application using Fixed Output Regulator

## Application Note (Continued)

When the adjustable regulator is used (Figure 3), the best performance is obtained with the positive side of the resistor R1 tied directly to the output terminal of the regulator rather than near the load. This eliminates line drops from appearing effectively in series with the reference and degrading regulation. For example, a 5V regulator with 0.05Ω resistance between the regulator and load will have a load regulation due to line resistance of 0.05Ω × I<sub>L</sub>. If R1 (=125Ω) is connected near the load, the effective line resistance will be 0.05Ω (1+R2/R1) or in this case, it is 4 times worse. In addition, the ground side of the resistor R2 can be returned near the ground of the load to provide remote ground sensing and improve load regulation.

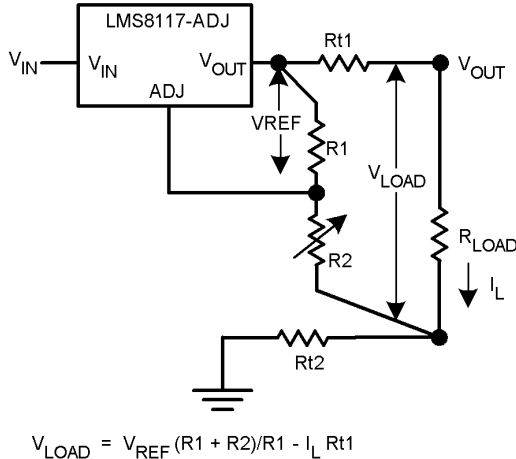


FIGURE 3. Best Load Regulation using Adjustable Output Regulator

### 4.0 PROTECTION DIODES

Under normal operation, the LMS8117A regulators do not need any protection diode. With the adjustable device, the internal resistance between the adjust and output terminals limits the current. No diode is needed to divert the current around the regulator even with capacitor on the adjust terminal. The adjust pin can take a transient signal of ±25V with respect to the output voltage without damaging the device.

When a output capacitor is connected to a regulator and the input is shorted to ground, the output capacitor will discharge into the output of the regulator. The discharge current depends on the value of the capacitor, the output voltage of the regulator, and rate of decrease of V<sub>IN</sub>. In the LMS8117A regulators, the internal diode between the output and input pins can withstand microsecond surge currents of 10A to 20A. With an extremely large output capacitor (≥1000 μF), and with input instantaneously shorted to ground, the regulator could be damaged.

In this case, an external diode is recommended between the output and input pins to protect the regulator, as shown in Figure 4.

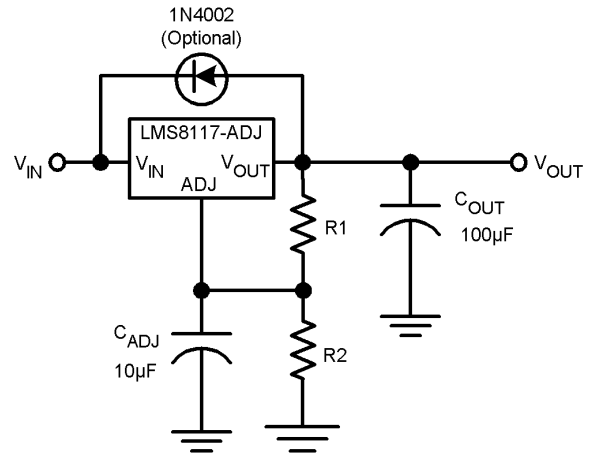


FIGURE 4. Regulator with Protection Diode

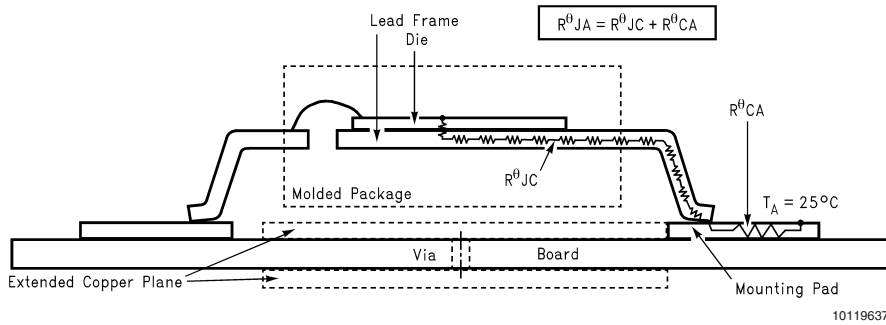
### 5.0 HEATSINK REQUIREMENTS

When an integrated circuit operates with an appreciable current, its junction temperature is elevated. It is important to quantify its thermal limits in order to achieve acceptable performance and reliability. This limit is determined by summing the individual parts consisting of a series of temperature rises from the semiconductor junction to the operating environment. A one-dimensional steady-state model of conduction heat transfer is demonstrated in Figure 5. The heat generated at the device junction flows through the die to the die attach pad, through the lead frame to the surrounding case material, to the printed circuit board, and eventually to the ambient environment. Below is a list of variables that may affect the thermal resistance and in turn the need for a heatsink.

R <sup>θJC</sup> (Component Variables)	R <sup>θCA</sup> (Application Variables)
Leadframe Size & Material	Mounting Pad Size, Material, & Location
No. of Conduction Pins	Placement of Mounting Pad
Die Size	PCB Size & Material
Die Attach Material	Traces Length & Width
Molding Compound Size and Material	Adjacent Heat Sources
	Volume of Air
	Ambient Temperature
	Shape of Mounting Pad



**Application Note** (Continued)



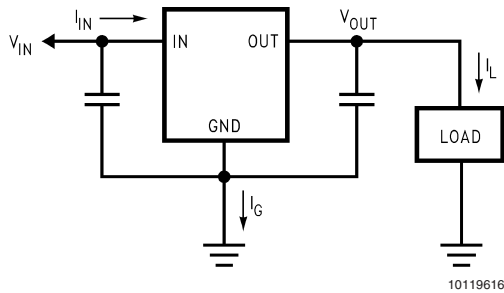
**FIGURE 5. Cross-sectional view of Integrated Circuit Mounted on a printed circuit board. Note that the case temperature is measured at the point where the leads contact with the mounting pad surface**

The LMS8117A regulators have internal thermal shutdown to protect the device from over-heating. Under all possible operating conditions, the junction temperature of the LMS8117A must be within the range of 0°C to 125°C. A heatsink may be required depending on the maximum power dissipation and maximum ambient temperature of the application. To determine if a heatsink is needed, the power dissipated by the regulator,  $P_D$ , must be calculated:

$$I_{IN} = I_L + I_G$$

$$P_D = (V_{IN} - V_{OUT})I_L + V_{IN}I_G$$

Figure 6 shows the voltages and currents which are present in the circuit.



**FIGURE 6. Power Dissipation Diagram**

The next parameter which must be calculated is the maximum allowable temperature rise,  $T_R(max)$ :

$$T_R(max) = T_J(max) - T_A(max)$$

where  $T_J(max)$  is the maximum allowable junction temperature (125°C), and  $T_A(max)$  is the maximum ambient temperature which will be encountered in the application.

Using the calculated values for  $T_R(max)$  and  $P_D$ , the maximum allowable value for the junction-to-ambient thermal resistance ( $\theta_{JA}$ ) can be calculated:

$$\theta_{JA} = T_R(max) / P_D$$

If the maximum allowable value for  $\theta_{JA}$  is found to be  $\geq 136^\circ\text{C/W}$  for SOT-223 package or  $\geq 92^\circ\text{C/W}$  for TO-252 package, no heatsink is needed since the package alone will dissipate enough heat to satisfy these requirements. If the calculated value for  $\theta_{JA}$  falls below these limits, a heatsink is required.

As a design aid, Table 1 shows the value of the  $\theta_{JA}$  of SOT-223 and TO-252 for different heatsink area. The copper patterns that we used to measure these  $\theta_{JA}$ s are shown at the end of the Application Notes Section. Figure 7 and Figure 8 reflects the same test results as what are in the Table 1.

Figure 9 and Figure 10 shows the maximum allowable power dissipation vs. ambient temperature for the SOT-223 and TO-252 device. Figure 11 and Figure 12 shows the maximum allowable power dissipation vs. copper area (in<sup>2</sup>) for the SOT-223 and TO-252 devices. Please see AN-1028 for power enhancement techniques to be used with SOT-223 and TO-252 packages.

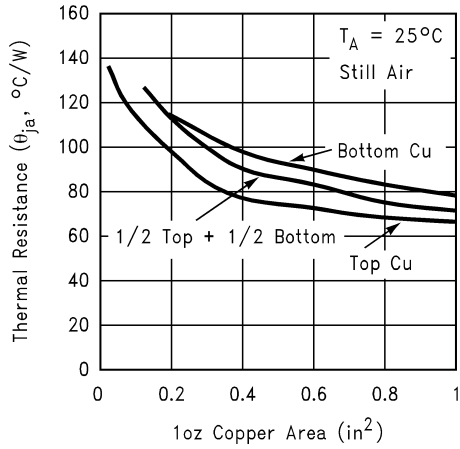
## Application Note (Continued)

**TABLE 1.  $\theta_{JA}$  Different Heatsink Area**

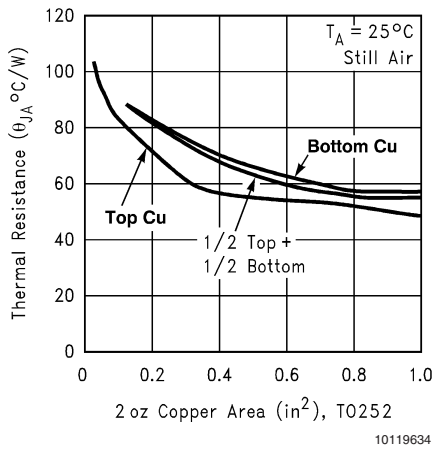
Layout	Copper Area		Thermal Resistance	
	Top Side (in <sup>2</sup> )*	Bottom Side (in <sup>2</sup> )	( $\theta_{JA}$ , °C/W) SOT-223	( $\theta_{JA}$ , °C/W) TO-252
1	0.0123	0	136	103
2	0.066	0	123	87
3	0.3	0	84	60
4	0.53	0	75	54
5	0.76	0	69	52
6	1	0	66	47
7	0	0.2	115	84
8	0	0.4	98	70
9	0	0.6	89	63
10	0	0.8	82	57
11	0	1	79	57
12	0.066	0.066	125	89
13	0.175	0.175	93	72
14	0.284	0.284	83	61
15	0.392	0.392	75	55
16	0.5	0.5	70	53

\*Tab of device attached to topside copper

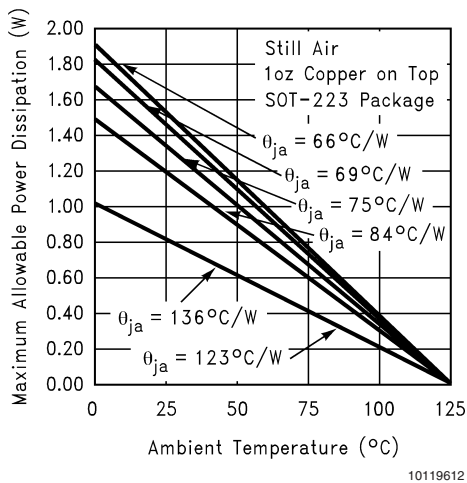
**Application Note** (Continued)



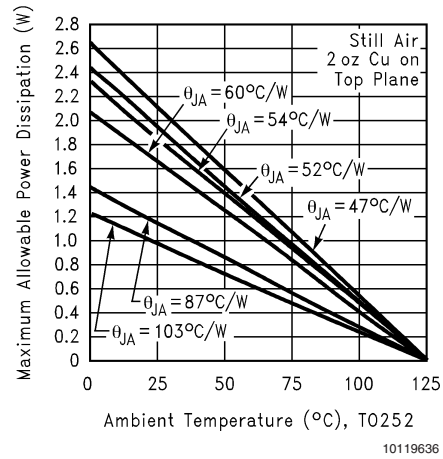
**FIGURE 7.**  $\theta_{JA}$  vs. 1oz Copper Area for SOT-223



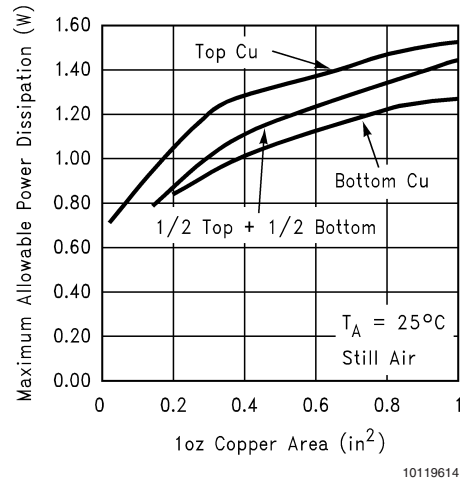
**FIGURE 8.**  $\theta_{JA}$  vs. 2oz Copper Area for TO-252



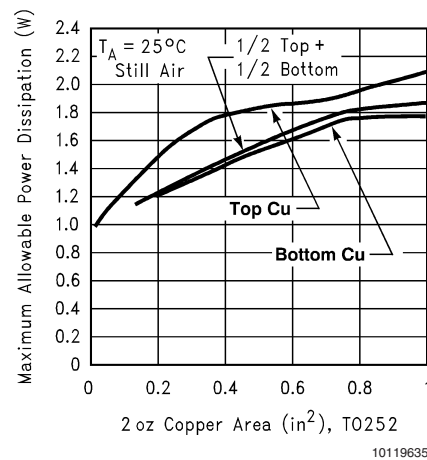
**FIGURE 9.** Maximum Allowable Power Dissipation vs. Ambient Temperature for SOT-223



**FIGURE 10.** Maximum Allowable Power Dissipation vs. Ambient Temperature for TO-252

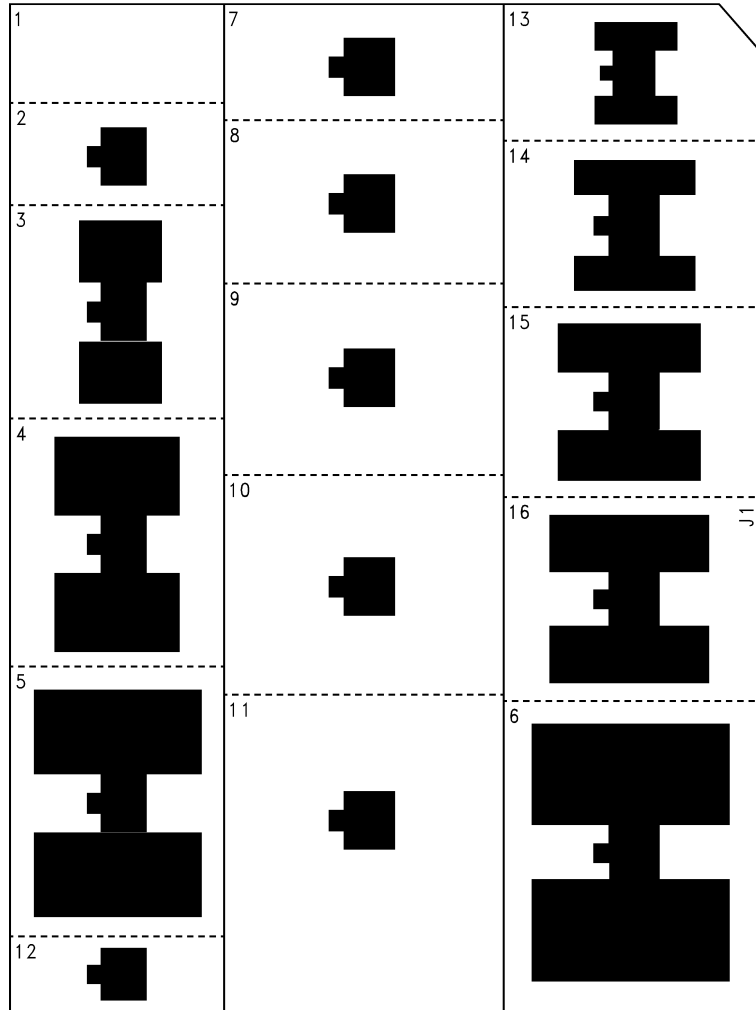


**FIGURE 11.** Maximum Allowable Power Dissipation vs. 1oz Copper Area for SOT-223



**FIGURE 12.** Maximum Allowable Power Dissipation vs. 2oz Copper Area for TO-252

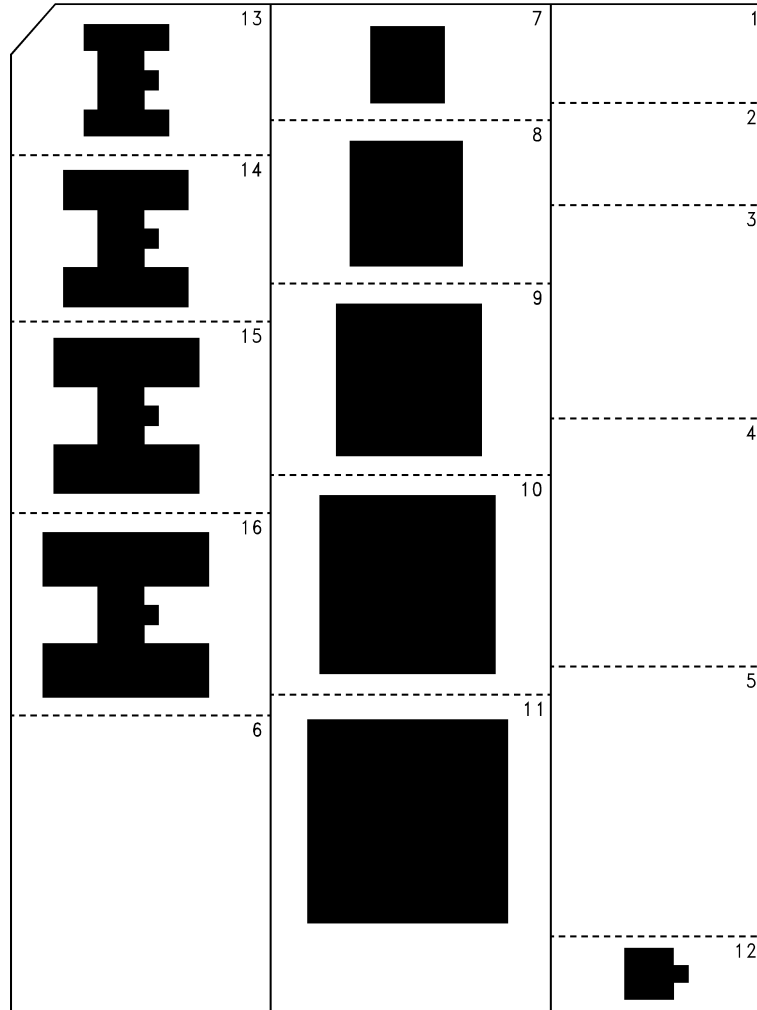
**Application Note** (Continued)



10119620

**FIGURE 13. Top View of the Thermal Test Pattern in Actual Scale**

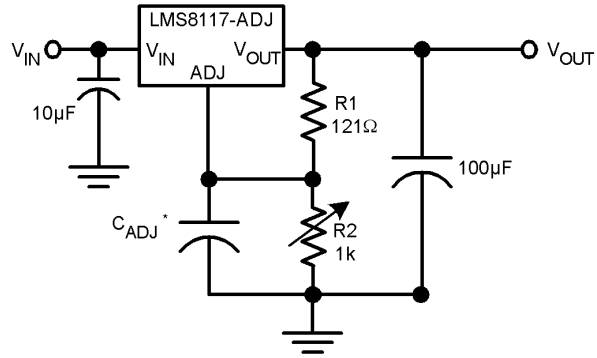
**Application Note** (Continued)



10119621

**FIGURE 14. Bottom View of the Thermal Test Pattern in Actual Scale**

## Typical Application Circuits

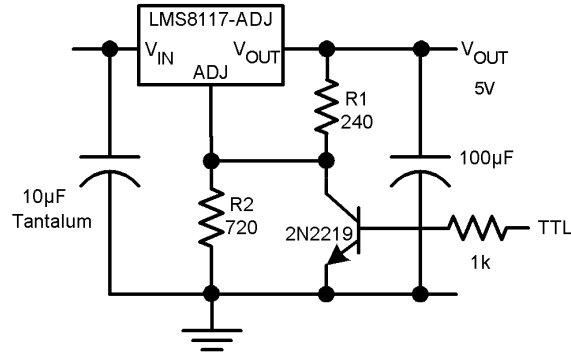


$$V_{OUT} = 1.25 (1 + R2/R1)$$

\*  $C_{ADJ}$  is optional, however it will improve ripple rejection

10119629

### 1.25V to 10V Adjustable Regulator with Improved Ripple Rejection

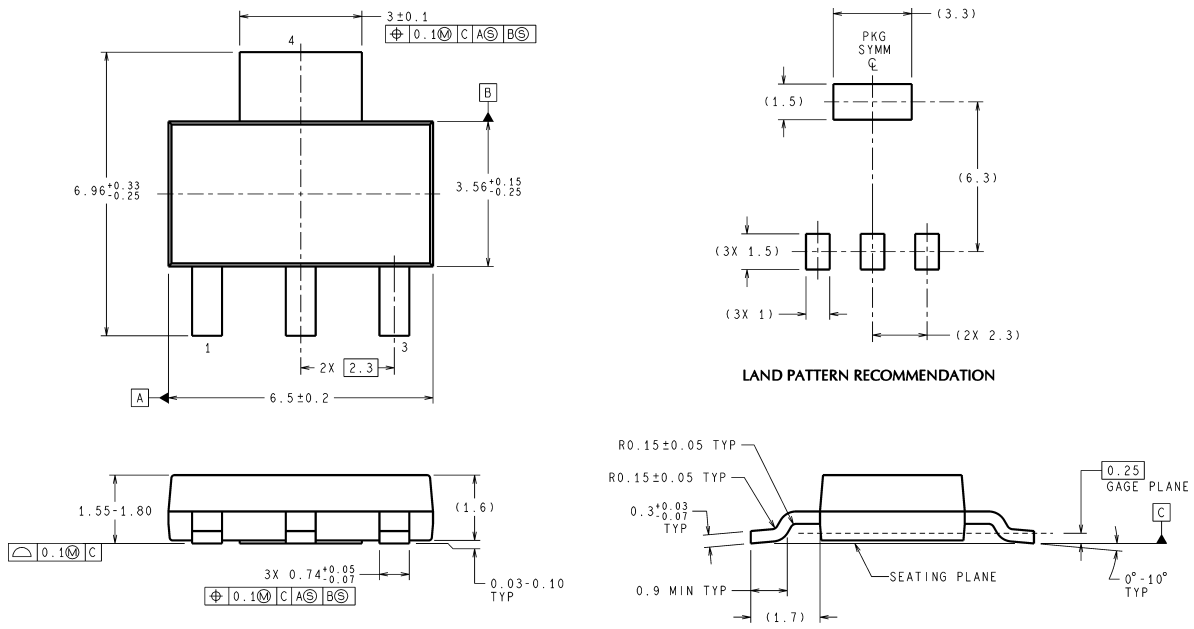


\* Min. Output  $\approx$  1.25V

10119627

### 5V Logic Regulator with Electronic Shutdown\*

**Physical Dimensions** inches (millimeters) unless otherwise noted

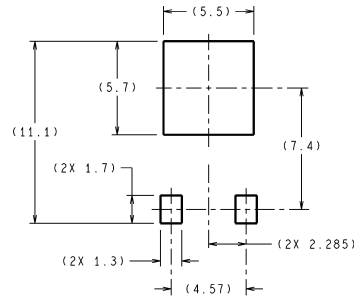


DIMENSIONS ARE IN MILLIMETERS

MP04A (Rev B)

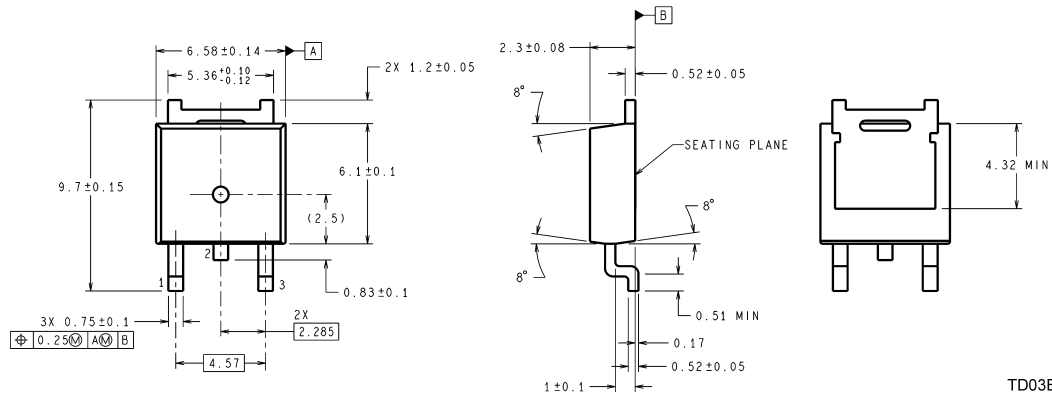
**3-Lead SOT-223**  
**NS Package Number MP04A**

**Physical Dimensions** inches (millimeters) unless otherwise noted (Continued)



DIMENSIONS ARE IN MILLIMETERS

**LAND PATTERN RECOMMENDATION**



TD03B (Rev C)

**3-Lead TO-252  
NS Package Number TD03B**

National does not assume any responsibility for use of any circuitry described, no circuit patent licenses are implied and National reserves the right at any time without notice to change said circuitry and specifications.

For the most current product information visit us at [www.national.com](http://www.national.com).


**LIFE SUPPORT POLICY**

NATIONAL'S PRODUCTS ARE NOT AUTHORIZED FOR USE AS CRITICAL COMPONENTS IN LIFE SUPPORT DEVICES OR SYSTEMS WITHOUT THE EXPRESS WRITTEN APPROVAL OF THE PRESIDENT AND GENERAL COUNSEL OF NATIONAL SEMICONDUCTOR CORPORATION. As used herein:

1. Life support devices or systems are devices or systems which, (a) are intended for surgical implant into the body, or (b) support or sustain life, and whose failure to perform when properly used in accordance with instructions for use provided in the labeling, can be reasonably expected to result in a significant injury to the user.
2. A critical component is any component of a life support device or system whose failure to perform can be reasonably expected to cause the failure of the life support device or system, or to affect its safety or effectiveness.

**BANNED SUBSTANCE COMPLIANCE**

National Semiconductor manufactures products and uses packing materials that meet the provisions of the Customer Products Stewardship Specification (CSP-9-111C2) and the Banned Substances and Materials of Interest Specification (CSP-9-111S2) and contain no "Banned Substances" as defined in CSP-9-111S2.

 **National Semiconductor**  
Americas Customer  
Support Center  
Email: [new.feedback@nsc.com](mailto:new.feedback@nsc.com)  
Tel: 1-800-272-9959

**National Semiconductor**  
Europe Customer Support Center  
Fax: +49 (0) 180-530 85 86  
Email: [europa.support@nsc.com](mailto:europa.support@nsc.com)  
Deutsch Tel: +49 (0) 69 9508 6208  
English Tel: +44 (0) 870 24 0 2171  
Français Tel: +33 (0) 1 41 91 8790

**National Semiconductor**  
Asia Pacific Customer  
Support Center  
Email: [ap.support@nsc.com](mailto:ap.support@nsc.com)

**National Semiconductor**  
Japan Customer Support Center  
Fax: 81-3-5639-7507  
Email: [jpn.feedback@nsc.com](mailto:jpn.feedback@nsc.com)  
Tel: 81-3-5639-7560

[www.national.com](http://www.national.com)