

## LP8340

# Low Dropout, Low $I_Q$ , 1.0A CMOS Linear Regulator

### General Description

The LP8340 low-dropout CMOS linear regulator is available in 5V, 3.3V, 2.5V, 1.8V and adjustable output versions. Packaged in the 6ld LLP package and 3ld DPAK. The LP8340 can deliver up to 1.0A output current.

Typical dropout voltage is 420mV at 1.0A for the 5.0V version, 540mV at 1.0A for the 3.3V version, 670mV at 1.0A for the 2.5V version and 680mV at 800mA for the 1.8V version.

The LP8340 includes a zener trimmed bandgap voltage reference, foldback current limiting and thermal overload limiting.

The LP8340 features a PMOS output transistor which unlike PNP type low dropout regulators requires no base drive current. This allows the device ground current to remain less than 50 $\mu$ A over operating temperature, supply voltage and irrespective of the load current.

### Features

- $\pm 1.5\%$  Typical  $V_{OUT}$  tolerance
- 420mV Typical Dropout @ 1.0A ( $V_O = 5V$ )
- Wide Operating Range 2.7V to 10V
- Internal 1.0A PMOS Output Transistor
- 19 $\mu$ A Typical Quiescent Current
- Thermal Overload Limiting
- Foldback Current Limiting
- Zener Trimmed Bandgap Reference
- Space saving LLP package
- Temperature Range
  - LP8340C 0°C to 125°C
  - LP8340I -40°C to 125°C

### Applications

- Hard Disk Drives
- Notebook Computers
- Battery Powered Electronics
- Portable Instrumentation

### Typical Applications

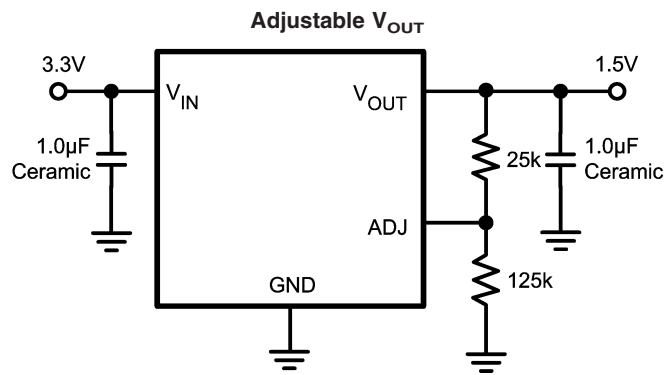
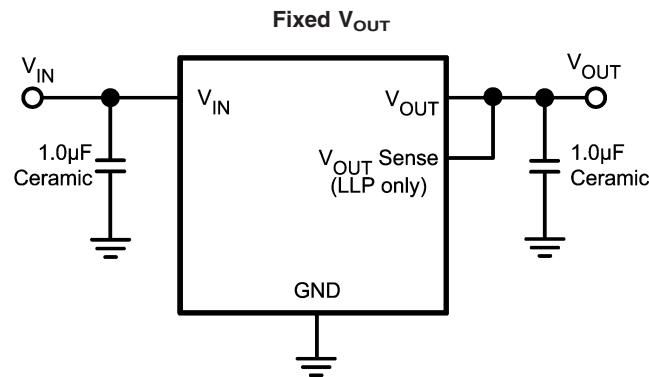

## Ordering Information

Package	Part Number	Package Marking	Transport Media	NSC Drawing
6-Pin LLP	LP8340CLD-ADJ	L041B	1k Units Tape and Reel	LDE06A
	LP8340CLDX-ADJ		4.5k Units Tape and Reel	
	LP8340CLD-1.8	L042B	1k Units Tape and Reel	
	LP8340CLDX-1.8		4.5k Units Tape and Reel	
	LP8340CLD-2.5	L043B	1k Units Tape and Reel	
	LP8340CLDX-2.5		4.5k Units Tape and Reel	
	LP8340CLD-3.3	L051B	1k Units Tape and Reel	
	LP8340CLDX-3.3		4.5k Units Tape and Reel	
	LP8340CLD-5.0	L044B	1k Units Tape and Reel	
	LP8340CLDX-5.0		4.5k Units Tape and Reel	
	LP8340ILD-ADJ	L078B	1k Units Tape and Reel	
	LP8340ILD-ADJ		4.5k Units Tape and Reel	
	LP8340ILD-1.8	L079B	1k Units Tape and Reel	
	LP8340ILD-1.8		4.5k Units Tape and Reel	
	LP8340ILD-2.5	L080B	1k Units Tape and Reel	
	LP8340ILD-2.5		4.5k Units Tape and Reel	
	LP8340ILD-3.3	L081B	1k Units Tape and Reel	
	LP8340ILD-3.3		4.5k Units Tape and Reel	
	LP8340ILD-5.0	L082B	1k Units Tape and Reel	
	LP8340ILD-5.0		4.5k Units Tape and Reel	
3-Pin DPAK	LP8340CDT-1.8	LP8340CDT-1.8	75 Units/Rail	TD03B
	LP8340CDTX-1.8		2.5k Units Tape and Reel	
	LP8340CDT-2.5	LP8340CDT-2.5	75 Units/Rail	
	LP8340CDTX-2.5		2.5k Units Tape and Reel	
	LP8340CDT-3.3	LP8340CDT-3.3	75 Units/Rail	
	LP8340CDTX-3.3		2.5k Units Tape and Reel	
	LP8340CDT-5.0	LP8340CDT-5.0	75 Units/Rail	
	LP8340CDTX-5.0		2.5k Units Tape and Reel	
	LP8340IDT-1.8	LP8340IDT-1.8	75 Units/Rail	
	LP8340IDTX-1.8		2.5k Units Tape and Reel	
	LP8340IDT-2.5	LP8340IDT-2.5	75 Units/Rail	
	LP8340IDTX-2.5		2.5k Units Tape and Reel	
	LP8340IDT-3.3	LP8340IDT-3.3	75 Units/Rail	
	LP8340IDTX-3.3		2.5k Units Tape and Reel	
	LP8340IDT-5.0	LP8340IDT-5.0	75 Units/Rail	
	LP8340IDTX-5.0		2.5k Units Tape and Reel	

# Connection Diagrams

**6-Pin LLP  
FIXED OUTPUT VOLTAGE**

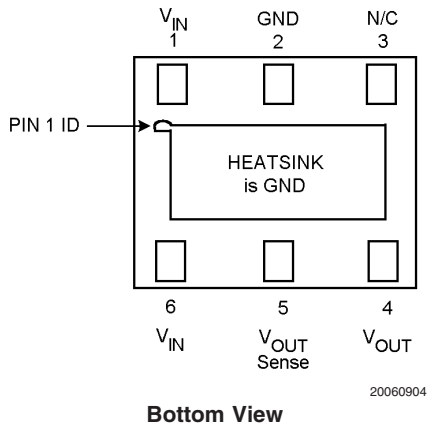

**6-Pin LLP  
ADJUSTABLE OUTPUT VOLTAGE**

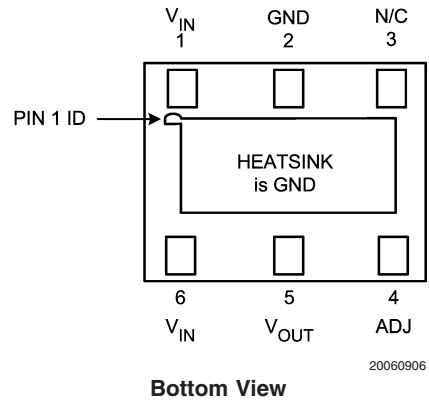

**Note:**  $V_{IN}$  Pins (Pin 1 & 6) must be connected together externally for full 1 amp operation (500mA max per pin).  
 $V_{OUT}$  Sense (Pin 5) must be connected to  $V_{OUT}$  (Pin 4).

**T0-252**

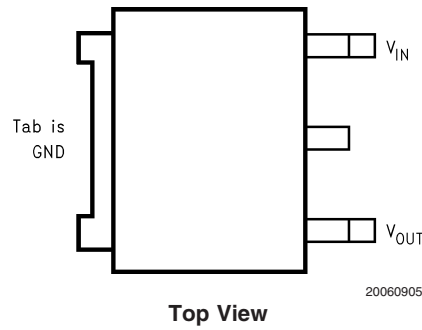

### Absolute Maximum Ratings (Notes 1, 2)

If Military/Aerospace specified devices are required, please contact the National Semiconductor Sales Office/Distributors for availability and specifications.

$V_{IN}$ , $V_{OUT}$ , $V_{OUT}$ Sense, ADJ	-0.3V to 12V
Storage Temperature Range	-65°C to 160°C
Junction Temperature ( $T_J$ )	150°C
Power Dissipation	(Note 3)
ESD Rating	

Human Body Model (Note 6) 2kV

Machine Model 200V

### Operating Ratings (Notes 1, 2)

Supply Voltage	2.7 to 10V
Temperature Range	
LP8340C	0°C to 125°C
LP8340I	-40°C to 125°C

### LP8340C Electrical Characteristics

Unless otherwise specified all limits guaranteed for  $V_{IN} = V_O + 1V$ ,  $C_{IN} = C_{OUT} = 10\mu F$ ,  $T_J = 25^\circ C$ . **Boldface** limits apply over the full operating temperature range of  $T_J = 0^\circ C$  to 125°C

Symbol	Parameter	Conditions	Min (Note 5)	Typ (Note 4)	Max (Note 5)	Units
$V_{IN}$	Input Voltage	LP8340-ADJ, 1.8, 2.5 LP8340-3.3, 5.0	<b>2.7</b>		<b>10</b> <b>10</b>	V
$V_{OUT}$	Output Voltage	LP8340-ADJ, ADJ = OUT $I_{OUT} = 10mA$ , $V_{IN} = 2.7V$ , $T_J = 25^\circ C$ $100\mu A \leq I_{OUT} \leq 800mA$ , $3.0V \leq V_{IN} \leq V_{OUT} + 4V$ $800mA < I_{OUT} \leq 1.0A$ , $3.2V \leq V_{IN} \leq V_{OUT} + 4V$	1.231 <b>1.213</b> <b>1.213</b>	1.250	1.269 <b>1.288</b> <b>1.288</b>	V
		LP8340-1.8 $I_{OUT} = 10mA$ , $V_{IN} = 2.8V$ , $T_J = 25^\circ C$ $100\mu A \leq I_{OUT} \leq 800mA$ , $3.2V \leq V_{IN} \leq 6V$ $800mA < I_{OUT} \leq 1.0A$ , $3.4V \leq V_{IN} \leq 6V$	1.773 <b>1.746</b> <b>1.746</b>	1.800	1.827 <b>1.854</b> <b>1.854</b>	V
		LP8340-2.5 $I_{OUT} = 10mA$ , $V_{IN} = 3.8V$ , $T_J = 25^\circ C$ $100\mu A \leq I_{OUT} \leq 1.0A$ , $3.8V \leq V_{IN} \leq 6.5V$	2.463 <b>2.425</b>	2.500	2.538 <b>2.575</b>	V
		LP8340-3.3 $I_{OUT} = 10mA$ , $V_{IN} = 4.3V$ , $T_J = 25^\circ C$ $100\mu A \leq I_{OUT} \leq 1.0A$ , $4.3V \leq V_{IN} \leq 7.5V$	3.250 <b>3.201</b>	3.300	3.350 <b>3.399</b>	V
		LP8340-5.0 $I_{OUT} = 10mA$ , $V_{IN} = 6V$ , $T_J = 25^\circ C$ $100\mu A \leq I_{OUT} \leq 1.0A$ , $6V \leq V_{IN} \leq 9V$	4.925 <b>4.850</b>	5.000	5.075 <b>5.150</b>	V
		$\Delta V_O$	Load Regulation	LP8340-ADJ, ADJ=OUT $I_{OUT} = 1mA$ to 1.0A, $V_{IN} = 3.2V$		6
	LP8340-1.8 $I_{OUT} = 1mA$ to 1.0A, $V_{IN} = 3.4V$			8	<b>30</b>	
	LP8340-2.5 $I_{OUT} = 1mA$ to 1.0A, $V_{IN} = 3.5V$			15	<b>50</b>	
	LP8340-3.3 $I_{OUT} = 1mA$ to 1.0A, $V_{IN} = 4.3V$			20	<b>75</b>	
	LP8340-5.0 $I_{OUT} = 1mA$ to 1.0A, $V_{IN} = 6V$			25	<b>100</b>	
$\Delta V_O$	Line Regulation	$V_{OUT} + 0.5V \leq V_{IN} \leq 10V$ , $I_{OUT} = 25mA$ (Note 7)		4	<b>15</b>	mV

## LP8340C Electrical Characteristics (Continued)

Unless otherwise specified all limits guaranteed for  $V_{IN} = V_{O+} + 1V$ ,  $C_{IN} = C_{OUT} = 10\mu F$ ,  $T_J = 25^\circ C$ . **Boldface** limits apply over the full operating temperature range of  $T_J = 0^\circ C$  to  $125^\circ C$

Symbol	Parameter	Conditions	Min (Note 5)	Typ (Note 4)	Max (Note 5)	Units
$V_{IN} - V_O$	Dropout Voltage (Note 7) (Note 8)	LP8340-1.8 $I_{OUT} = 800mA$		680	<b>1400</b>	mV
		LP8340-2.5 $I_{OUT} = 800mA$		550	<b>1000</b>	
		LP8340-2.5 $I_{OUT} = 1.0A$		670	<b>1300</b>	
		LP8340-3.3 LP8340-ADJ, $V_{OUT} = 3.3V$ , $I_{OUT} = 800mA$		420	<b>800</b>	
		LP8340-3.3 LP8340-ADJ, $I_{OUT} = 1.0A$		540	<b>1000</b>	
		LP8340-5.0 $I_{OUT} = 800mA$		330	<b>650</b>	
		LP8340-5.0 $I_{OUT} = 1.0A$		420	<b>800</b>	
		$I_Q$	Quiescent Current	$V_{IN} \leq 10V$		
	Minimum Load Current	$V_{IN} - V_{OUT} \leq 4V$			<b>100</b>	$\mu A$
$I_{LIMIT}$	Foldback Current Limit	$V_{IN} - V_{OUT} > 5V$		450		mA
		$V_{IN} - V_{OUT} < 4V$		1600		
	Ripple Rejection Ratio	$V_{IN} (dc) = V_{OUT} + 2V$ $V_{IN} (ac) = 1 V_{P-P} @ 120Hz$	<b>48</b>	55		dB
$T_{SD}$	Thermal Shutdown Temp. Thermal Shutdown Hyst.			160		$^\circ C$
				10		
	ADJ Input Leakage Current	$V_{ADJ} = 1.5V$ or $0V$		$\pm 0.01$	$\pm 100$	nA
	$V_{OUT}$ Leakage Current	LP8340-ADJ ADJ = OUT, $V_{OUT} = 2V$ , $V_{IN} = 10V$			10	$\mu A$
		LP8340-1.8, $V_{OUT} = 2.5V$ , $V_{IN} = 10V$			10	
		LP8340-2.5, $V_{OUT} = 3.5V$ , $V_{IN} = 10V$			10	
		LP8340-3.3, $V_{OUT} = 4V$ , $V_{IN} = 10V$			10	
		LP8340-5.0, $V_{OUT} = 6V$ , $V_{IN} = 10V$			10	
$e_n$	Output Noise	10Hz to 10kHz, $R_L = 1k\Omega$ , $C_{OUT} = 10\mu F$		250		$\mu V_{rms}$

## LP8340I Electrical Characteristics

Unless otherwise specified all limits guaranteed for  $V_{IN} = V_{O+} + 1V$ ,  $C_{IN} = C_{OUT} = 10\mu F$ ,  $T_J = 25^\circ C$ . **Boldface** limits apply over the full operating temperature range of  $T_J = -40^\circ C$  to  $125^\circ C$

Symbol	Parameter	Conditions	Min (Note 5)	Typ (Note 4)	Max (Note 5)	Units
$V_{IN}$	Input Voltage	LP8340-ADJ, 1.8, 2.5 LP8340-3.3, 5.0	<b>2.7</b>		<b>10</b> <b>10</b>	V

## LP8340I Electrical Characteristics (Continued)

Unless otherwise specified all limits guaranteed for  $V_{IN} = V_{O+} + 1V$ ,  $C_{IN} = C_{OUT} = 10\mu F$ ,  $T_J = 25^\circ C$ . **Boldface** limits apply over the full operating temperature range of  $T_J = -40^\circ C$  to  $125^\circ C$

Symbol	Parameter	Conditions	Min (Note 5)	Typ (Note 4)	Max (Note 5)	Units
$V_{OUT}$	Output Voltage	LP8340-ADJ, ADJ = OUT $I_{OUT} = 10mA$ , $V_{IN} = 2.7V$ , $T_J = 25^\circ C$ $100\mu A \leq I_{OUT} \leq 800mA$ , $3.0V \leq V_{IN} \leq V_{OUT} + 4V$ $800mA < I_{OUT} \leq 1.0A$ , $3.2V \leq V_{IN} \leq V_{OUT} + 4V$	1.231 <b>1.213</b> <b>1.213</b>	1.250	1.269 <b>1.288</b> <b>1.288</b>	V
		LP8340-1.8 $I_{OUT} = 10mA$ , $V_{IN} = 2.8V$ , $T_J = 25^\circ C$ $100\mu A \leq I_{OUT} \leq 800mA$ , $3.2V \leq V_{IN} \leq 6V$ $800mA < I_{OUT} \leq 1.0A$ , $3.4V \leq V_{IN} \leq 6V$	1.773 <b>1.746</b> <b>1.746</b>	1.800	1.827 <b>1.854</b> <b>1.854</b>	V
		LP8340-2.5 $I_{OUT} = 10mA$ , $V_{IN} = 3.8V$ , $T_J = 25^\circ C$ $100\mu A \leq I_{OUT} \leq 1.0A$ , $3.8V \leq V_{IN} \leq 6.5V$	2.463 <b>2.425</b>	2.500	2.538 <b>2.575</b>	V
		LP8340-3.3 $I_{OUT} = 10mA$ , $V_{IN} = 4.3V$ , $T_J = 25^\circ C$ $100\mu A \leq I_{OUT} \leq 1.0A$ , $4.3V \leq V_{IN} \leq 7.5V$	3.250 <b>3.201</b>	3.300	3.350 <b>3.399</b>	V
		LP8340-5.0 $I_{OUT} = 10mA$ , $V_{IN} = 6V$ , $T_J = 25^\circ C$ $100\mu A \leq I_{OUT} \leq 1.0A$ , $6V \leq V_{IN} \leq 9V$	4.925 <b>4.850</b>	5.000	5.075 <b>5.150</b>	V
$\Delta V_O$	Load Regulation	LP8340-ADJ, ADJ=OUT $I_{OUT} = 1mA$ to $1.0A$ , $V_{IN} = 3.2V$		6	<b>25</b>	mV
		LP8340-1.8 $I_{OUT} = 1mA$ to $1.0A$ , $V_{IN} = 3.4V$		8	<b>30</b>	
		LP8340-2.5 $I_{OUT} = 1mA$ to $1.0A$ , $V_{IN} = 3.5V$		15	<b>50</b>	
		LP8340-3.3 $I_{OUT} = 1mA$ to $1.0A$ , $V_{IN} = 4.3V$		20	<b>75</b>	
		LP8340-5.0 $I_{OUT} = 1mA$ to $1.0A$ , $V_{IN} = 6V$		25	<b>100</b>	
$\Delta V_O$	Line Regulation	$V_{OUT} + 0.5V \leq V_{IN} \leq 10V$ , $I_{OUT} = 25mA$ (Note 7)		4	<b>15</b>	mV
$V_{IN} - V_O$	Dropout Voltage (Note 7) (Note 8)	LP8340-1.8 $I_{OUT} = 800mA$		680	<b>1400</b>	mV
		LP8340-2.5 $I_{OUT} = 800mA$		550	<b>1000</b>	
		LP8340-2.5 $I_{OUT} = 1.0A$		670	<b>1300</b>	
		LP8340-3.3 LP8340-ADJ, $V_{OUT} = 3.3V$ , $I_{OUT} = 800mA$		420	<b>800</b>	
		LP8340-3.3 LP8340-ADJ, $I_{OUT} = 1.0A$		540	<b>1000</b>	
		LP8340-5.0 $I_{OUT} = 800mA$		330	<b>650</b>	
		LP8340-5.0 $I_{OUT} = 1.0A$		420	<b>800</b>	
		$I_Q$	Quiescent Current	$V_{IN} \leq 10V$		
	Minimum Load Current	$V_{IN} - V_{OUT} \leq 4V$			<b>100</b>	$\mu A$
$I_{LIMIT}$	Foldback Current Limit	$V_{IN} - V_{OUT} > 5V$		450		mA
		$V_{IN} - V_{OUT} < 4V$		1600		
	Ripple Rejection Ratio	$V_{IN} (dc) = V_{OUT} + 2V$ $V_{IN} (ac) = 1 V_{P-P} @ 120Hz$	<b>48</b>	55		dB

## LP8340I Electrical Characteristics (Continued)

Unless otherwise specified all limits guaranteed for  $V_{IN} = V_O + 1V$ ,  $C_{IN} = C_{OUT} = 10\mu F$ ,  $T_J = 25^\circ C$ . **Boldface** limits apply over the full operating temperature range of  $T_J = -40^\circ C$  to  $125^\circ C$

Symbol	Parameter	Conditions	Min (Note 5)	Typ (Note 4)	Max (Note 5)	Units
$T_{SD}$	Thermal Shutdown Temp.			160		$^\circ C$
	Thermal Shutdown Hyst.			10		
	ADJ Input Leakage Current	$V_{ADJ} = 1.5V$ or $0V$		$\pm 0.01$	$\pm 100$	nA
	$V_{OUT}$ Leakage Current	LP8340-ADJ ADJ = OUT, $V_{OUT} = 2V$ , $V_{IN} = 10V$			10	$\mu A$
		LP8340-1.8, $V_{OUT} = 2.5V$ , $V_{IN} = 10V$			10	
		LP8340-2.5, $V_{OUT} = 3.5V$ , $V_{IN} = 10V$			10	
		LP8340-3.3, $V_{OUT} = 4V$ , $V_{IN} = 10V$			10	
		LP8340-5.0, $V_{OUT} = 6V$ , $V_{IN} = 10V$			10	
$e_n$	Output Noise	10Hz to 10kHz, $R_L = 1k\Omega$ , $C_{OUT} = 10\mu F$		250		$\mu V_{rms}$

**Note 1:** Absolute Maximum ratings indicate limits beyond which damage may occur. Electrical specifications do not apply when operating the device outside of its rated operating conditions.

**Note 2:** All voltages are with respect to the potential at the ground pin.

**Note 3:** Maximum Power dissipation for the device is calculated using the following equations:

$$P_D = \frac{T_{J(MAX)} - T_A}{\theta_{JA}}$$

where  $T_{J(MAX)}$  is the maximum junction temperature,  $T_A$  is the ambient temperature, and  $\theta_{JA}$  is the junction-to-ambient thermal resistance. The value of the  $\theta_{JA}$  for the LLP package is specifically dependant on the PCB trace area, trace material, and the number of layers and thermal vias. For improved thermal resistance and power dissipation for the LLP package, refer to Application Note AN-1187.

**Note 4:** Typical Values represent the most likely parametric norm.

**Note 5:** All limits are guaranteed by testing or statistical analysis.

**Note 6:** Human body model 1.5k $\Omega$  in series with 100pF.

**Note 7:** Condition does not apply to input voltages below 2.7V since this is the minimum input operating voltage.

**Note 8:** Dropout voltage is measured by reducing  $V_{IN}$  until  $V_O$  drops 100mV from its normal value.

## Typical Performance Characteristics

Unless otherwise specified,  $V_{IN} = V_O + 1.5V$ ,  $C_{IN} = C_{OUT} = 10\mu F$  X7R ceramic,  $T_J = 25^\circ C$

**Output Voltage Change vs. Temperature**

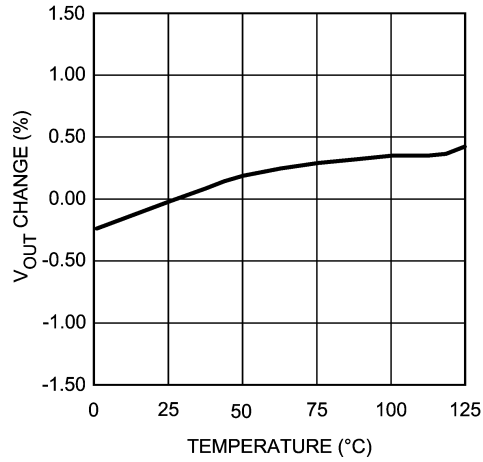

20060907

**Dropout Voltage vs. Load Current**

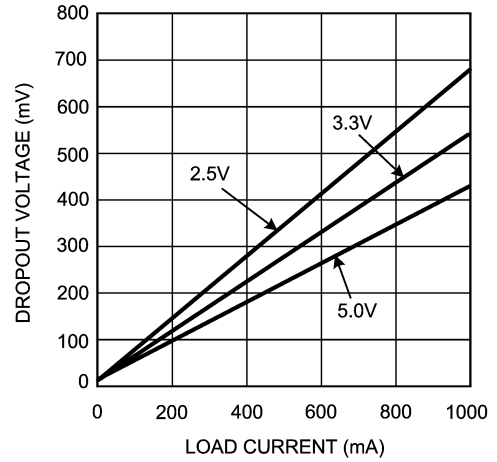

20060908

**Ground Current vs. Temperature ( $I_{LOAD} = 1A$ )**

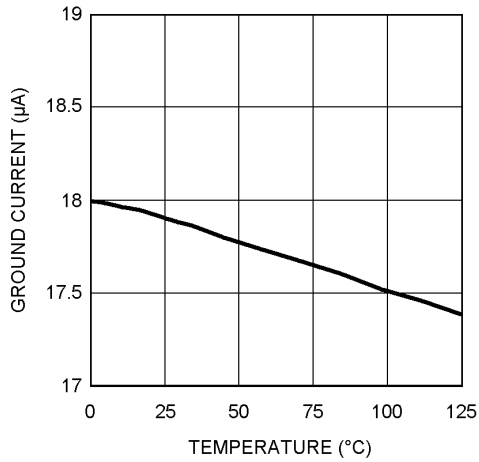

20060909

**Ground Current vs. Load Current**

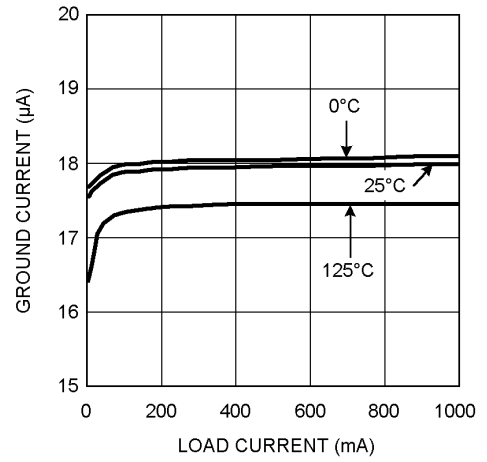

20060910

**Ground Current vs. Input Voltage**

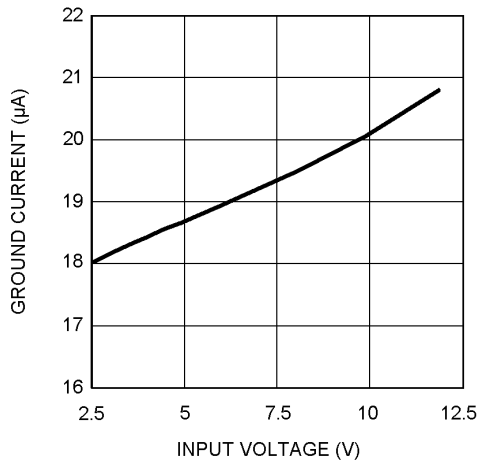

20060911

**Ripple Rejection Ratio vs. Frequency**

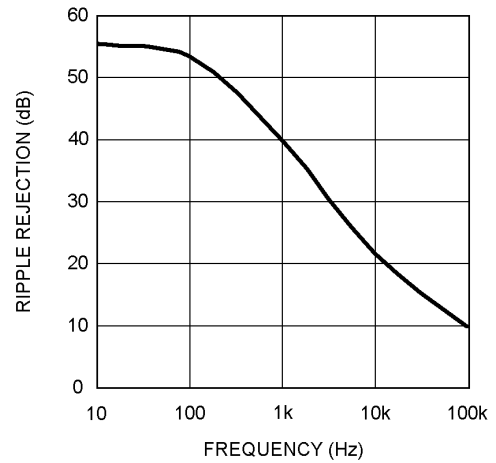

20060912



# Typical Performance Characteristics (Continued)

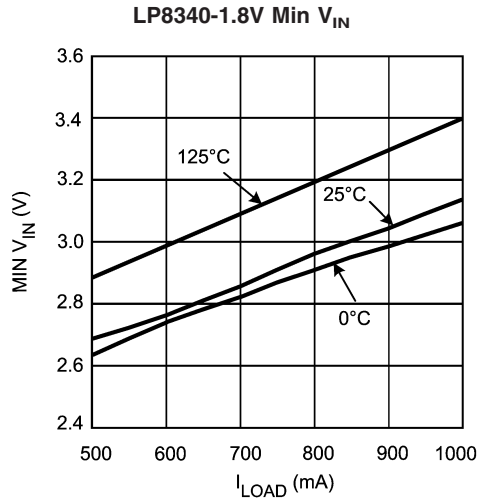

20060919

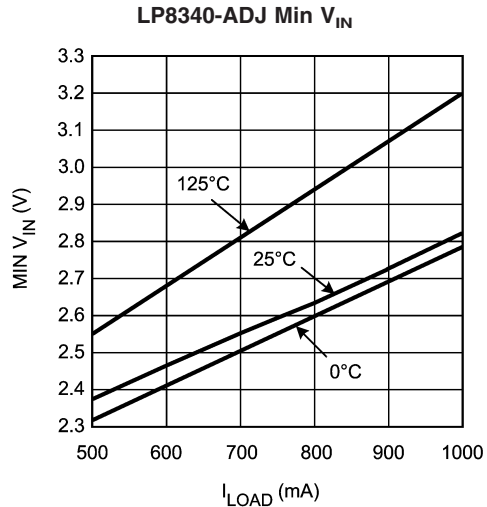

20060920

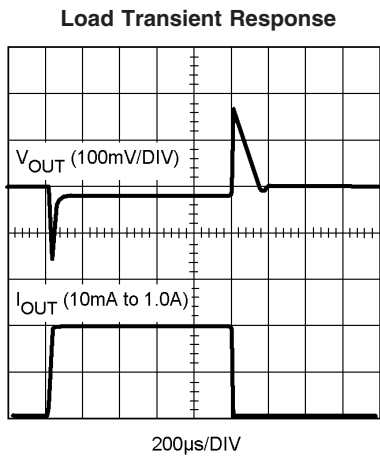

20060913

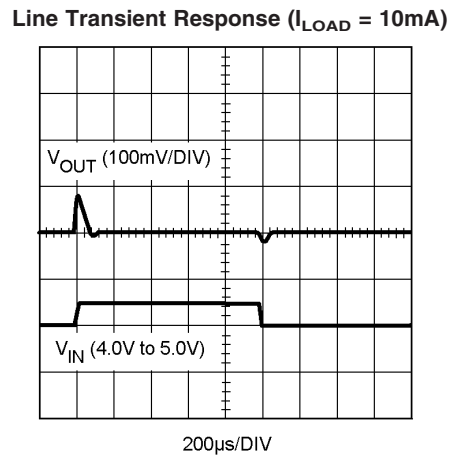

20060914

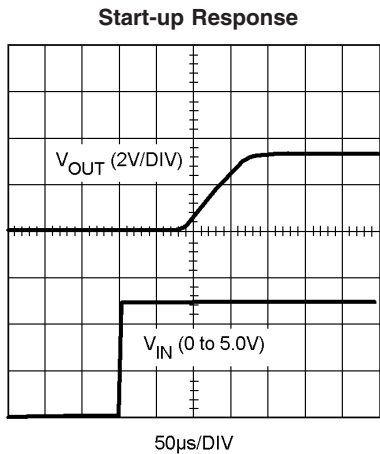

20060915

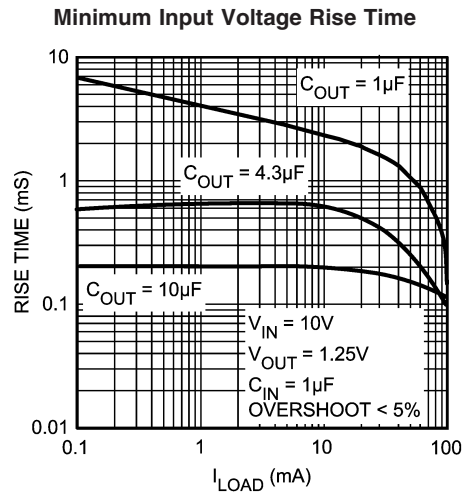

20060921

# Typical Performance Characteristics (Continued)

Minimum Input Voltage Rise Time

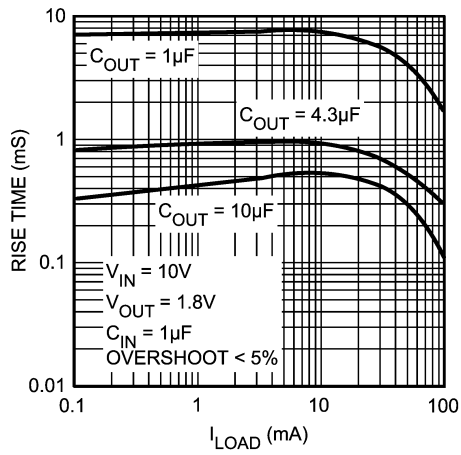

20060922

Minimum Input Voltage Rise Time

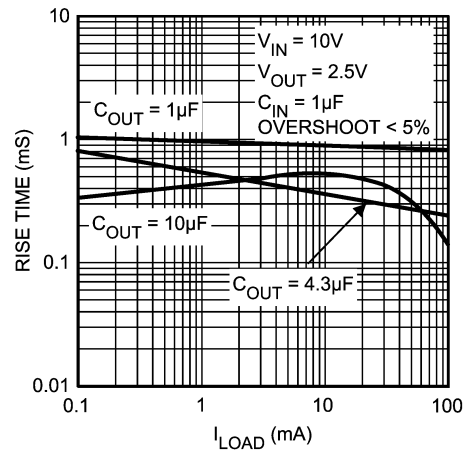

20060923

Minimum Input Voltage Rise Time

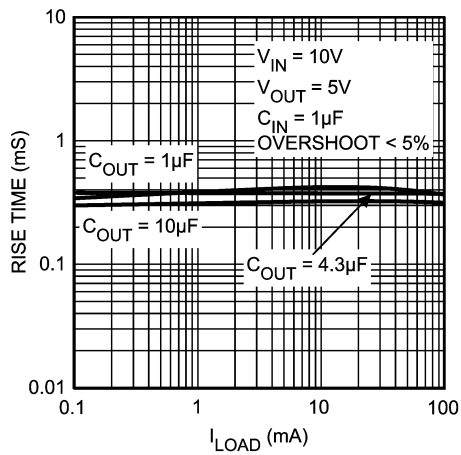

20060924

Minimum Input Voltage Rise Time

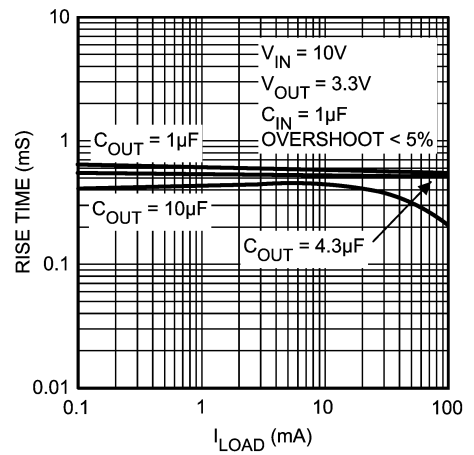

20060925

## Applications Section

### GENERAL INFORMATION

The LP8340 is a low-dropout, low quiescent current linear regulator. As shown in *Figure 1* it consists of a 1.25V reference, error amplifier, MOSFET driver, PMOS pass transistor and for the fixed output versions, an internal feedback network ( $R_1/R_2$ ). In addition, the device is protected from overload by a thermal shutdown circuit and a foldback current limit circuit.

The 1.25V reference is connected to the inverting input of the error amplifier. Regulation of the output voltage is

achieved by means of negative feedback to the non-inverting input of the error amplifier. Feedback resistors  $R_1$  and  $R_2$  are either internal or external to the device, depending on whether it is a fixed voltage version or the adjustable version. The negative feedback and high open loop gain of the error amplifier cause the two inputs of the error amp to be virtually equal in voltage. If the output voltage changes due to load changes, the error amplifier and MOSFET driver provide the appropriate drive to the pass transistor to maintain the error amplifier's inputs as virtually equal.

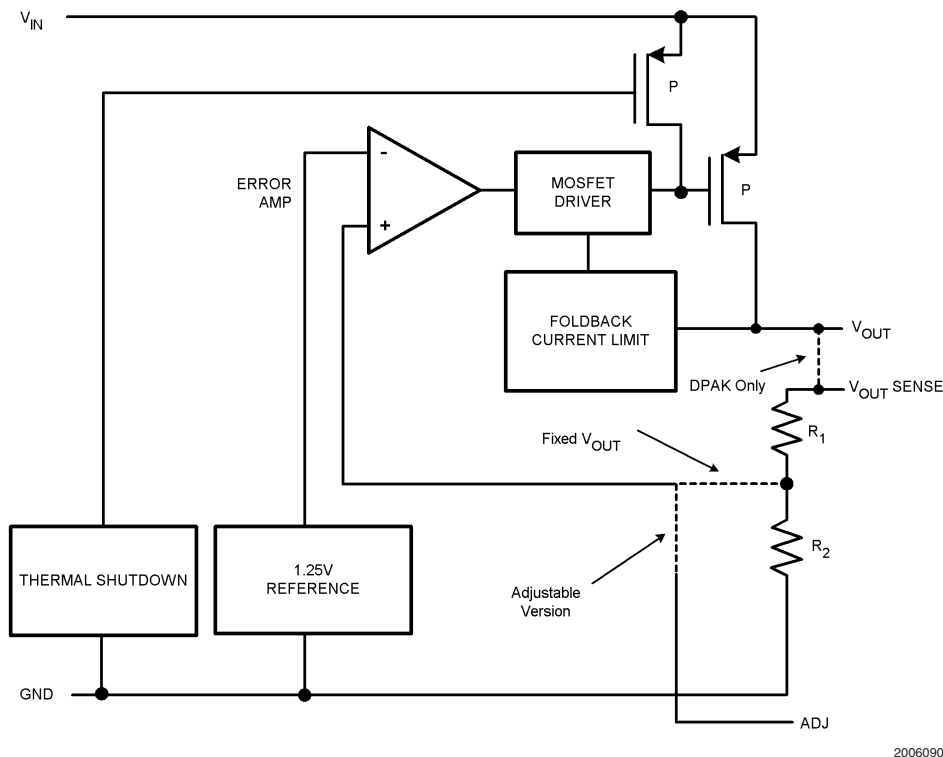

20060903

FIGURE 1. LP8340 Functional Block Diagram

### EXTERNAL CAPACITOR

An input capacitor of 1 $\mu$ F or greater is required between the LP8340  $V_{IN}$  pin and ground. While 1 $\mu$ F will provide adequate bypassing of the  $V_{IN}$  supply larger values of input capacitor (i.e. 10 $\mu$ F) can provide improved bypassing of power supply noise.

Stable operation can be achieved with an output capacitor of 1 $\mu$ F or greater, either ceramic X7R dielectric or aluminum/tantalum electrolytic. While the minimum capacitor value is 1 $\mu$ F, the typical output capacitor values selected range from 1 $\mu$ F to 10 $\mu$ F. The larger values provide improved load-transient response, power supply rejection and stability.

### OUTPUT VOLTAGE SETTING (ADJ VERSION ONLY)

The output voltage is set according to the amount of negative feedback (Note that the pass transistor inverts the feedback signal). This feedback is determined by  $R_1$  and  $R_2$  with the resulting output voltage represented by the following equation:

$$V_O = V_{REF} \left[ \frac{R_1}{R_2} + 1 \right]$$

Use the following equation to determine the values of  $R_1$  and  $R_2$  for a desired  $V_{OUT}$  ( $R_2 = 100\text{k}\Omega$  is recommended).

$$R_1 = R_2 \left[ \frac{V_O}{1.25\text{V}} - 1 \right]$$

### MINIMUM LOAD CURRENT

A minimum load of 100 $\mu$ A is required for regulation and stability over the entire operating temperature range. If actual load current falls below 100 $\mu$ A it is recommended that a resistor of value  $R_L = V_O/100\mu\text{A}$  be placed between  $V_O$  and ground.

## Applications Section (Continued)

### START UP CONSIDERATIONS

Under certain operating conditions, overshoot of  $V_{OUT}$  at start-up can occur. The observed overshoot is a function of rise time of  $V_{IN}$  waveform,  $C_{OUT}$ , start-up load current, and

$V_{IN}-V_{OUT}$  differential. The relationship between these conditions is shown in the Typical Performance Characteristics curves (Minimum Input Voltage Rise Time).  $V_{IN}$  rise times above the curve result in <5% overshoot.

Customers are encouraged to check the suitability of LP8340 in their specific application.

**Physical Dimensions** inches (millimeters) unless otherwise noted

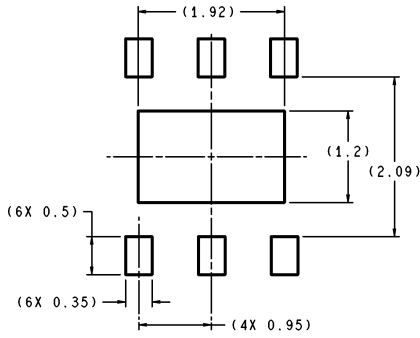

DIMENSIONS ARE IN MILLIMETERS

RECOMMENDED LAND PATTERN  
1:1 RATIO WITH PKG SOLDER PADS

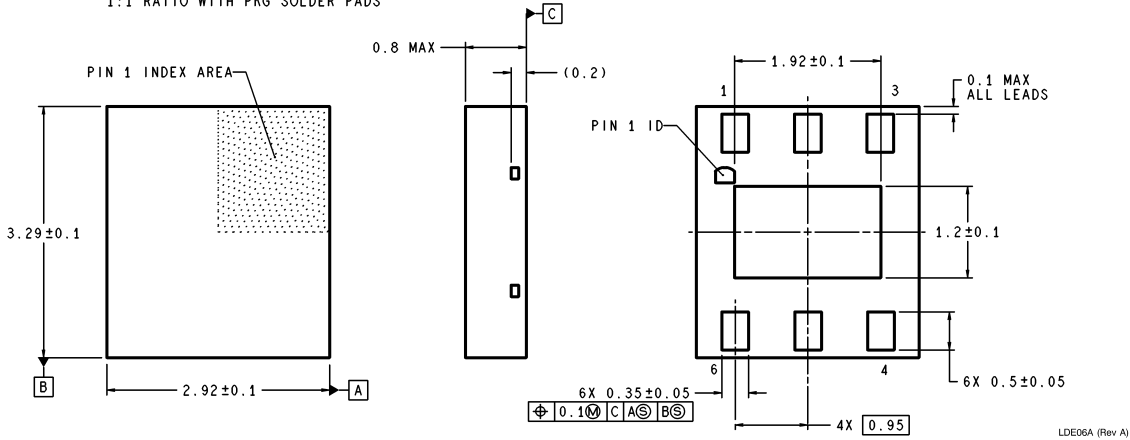

LDE06A (Rev A)

**6-Pin LLP**  
**NS Package Number LDE06A**

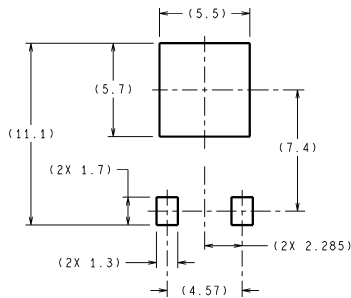

DIMENSIONS ARE IN MILLIMETERS

LAND PATTERN RECOMMENDATION

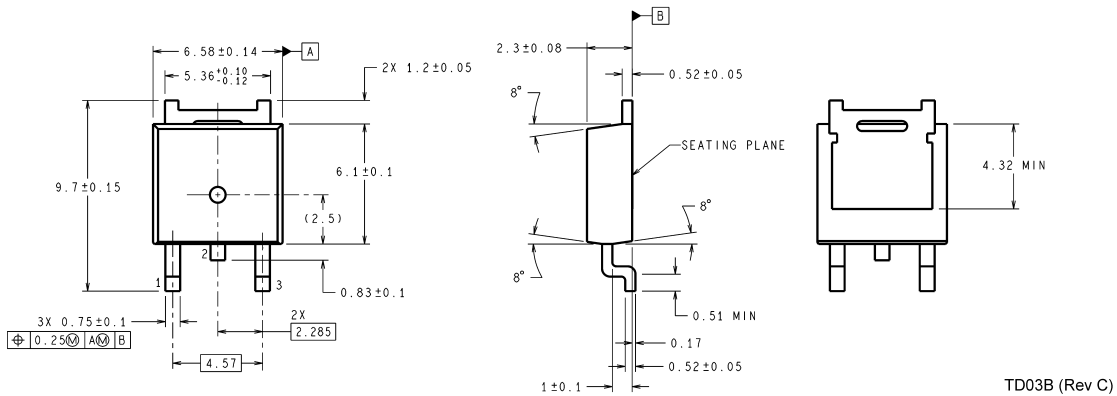

TD03B (Rev C)

**3-Pin DPAK**  
**NS Package Number TD03B**

## Notes

National does not assume any responsibility for use of any circuitry described, no circuit patent licenses are implied and National reserves the right at any time without notice to change said circuitry and specifications.

For the most current product information visit us at [www.national.com](http://www.national.com).

### LIFE SUPPORT POLICY

NATIONAL'S PRODUCTS ARE NOT AUTHORIZED FOR USE AS CRITICAL COMPONENTS IN LIFE SUPPORT DEVICES OR SYSTEMS WITHOUT THE EXPRESS WRITTEN APPROVAL OF THE PRESIDENT AND GENERAL COUNSEL OF NATIONAL SEMICONDUCTOR CORPORATION. As used herein:

1. Life support devices or systems are devices or systems which, (a) are intended for surgical implant into the body, or (b) support or sustain life, and whose failure to perform when properly used in accordance with instructions for use provided in the labeling, can be reasonably expected to result in a significant injury to the user.
2. A critical component is any component of a life support device or system whose failure to perform can be reasonably expected to cause the failure of the life support device or system, or to affect its safety or effectiveness.

### BANNED SUBSTANCE COMPLIANCE

National Semiconductor manufactures products and uses packing materials that meet the provisions of the Customer Products Stewardship Specification (CSP-9-111C2) and the Banned Substances and Materials of Interest Specification (CSP-9-111S2) and contain no "Banned Substances" as defined in CSP-9-111S2.



**National Semiconductor**  
Americas Customer  
Support Center  
Email: [new.feedback@nsc.com](mailto:new.feedback@nsc.com)  
Tel: 1-800-272-9959

[www.national.com](http://www.national.com)

**National Semiconductor**  
Europe Customer Support Center  
Fax: +49 (0) 180-530 85 86  
Email: [europa.support@nsc.com](mailto:europa.support@nsc.com)  
Deutsch Tel: +49 (0) 69 9508 6208  
English Tel: +44 (0) 870 24 0 2171  
Français Tel: +33 (0) 1 41 91 8790

**National Semiconductor**  
Asia Pacific Customer  
Support Center  
Email: [ap.support@nsc.com](mailto:ap.support@nsc.com)

**National Semiconductor**  
Japan Customer Support Center  
Fax: 81-3-5639-7507  
Email: [jpn.feedback@nsc.com](mailto:jpn.feedback@nsc.com)  
Tel: 81-3-5639-7560