



LD29080xx

800 mA fixed and adjustable output
very low drop voltage regulator

Features

- Very low dropout voltage (typ. 0.4 at 800 mA)
- Guaranteed output current up to 800 mA
- Fixed and adjustable output voltage ($\pm 1\%$ at 25 °C)
- Internal current and thermal limit
- Logic controlled electronic shutdown

Description

The LD29080xx is a high current, high accuracy, low-dropout voltage regulators series. These regulators feature 400 mV dropout voltages and very low ground current. Designed for high current loads, these devices also find applications in lower current, extremely low dropout-critical systems, where their tiny dropout voltage and ground current values are important attributes. Typical application are in power supply switching post regulation, series power supply for monitors, series power supply for VCRs and TVs, computer systems and battery powered systems.

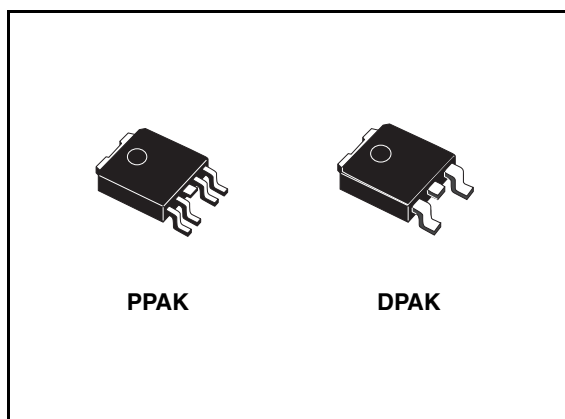

Table 1. Device summary

Part numbers	Order codes		Output voltages
	DPAK (tape and reel)	PPAK (tape and reel)	
LD29080XX15	LD29080DT15R	LD29080PT15R	1.5 V
LD29080XX18	LD29080DT18R	LD29080PT18R	1.8 V
LD29080XX25	LD29080DT25R	LD29080PT25R	2.5 V
LD29080XX33	LD29080DT33R	LD29080PT33R	3.3 V
LD29080XX50	LD29080DT50R	LD29080PT50R	5.0 V
LD29080XX80	LD29080DT80R	LD29080PT80R	8.0 V ⁽¹⁾
LD29080XX90	LD29080DT90R	LD29080PT90R	9.0 V
LD29080XX		LD29080PTR	ADJ

1. Available on request.

Contents

1	Diagram	3
2	Pin configuration	4
3	Maximum ratings	5
4	Electrical characteristics	6
5	Typical characteristics	14
6	Package mechanical data	17
7	Revision history	21

1 Diagram

Figure 1. Schematic diagram for adjustable version

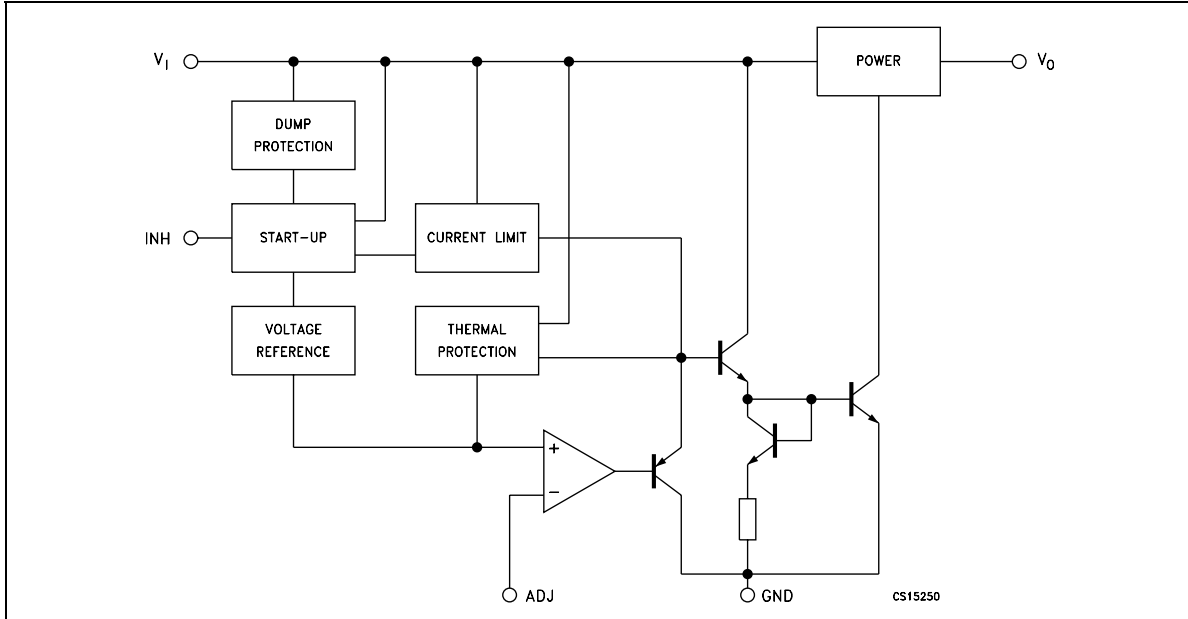
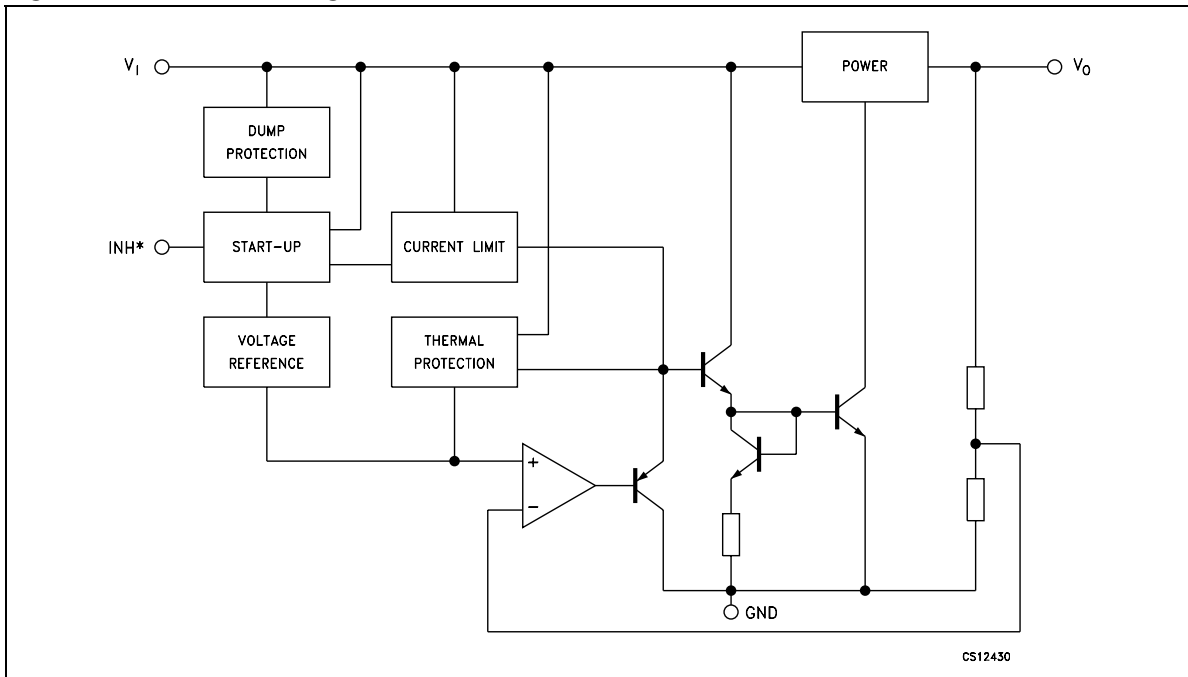

Figure 2. Schematic diagram for fixed version



* Only for version with inhibit function.

2 Pin configuration

Figure 3. Pin connections (top view)

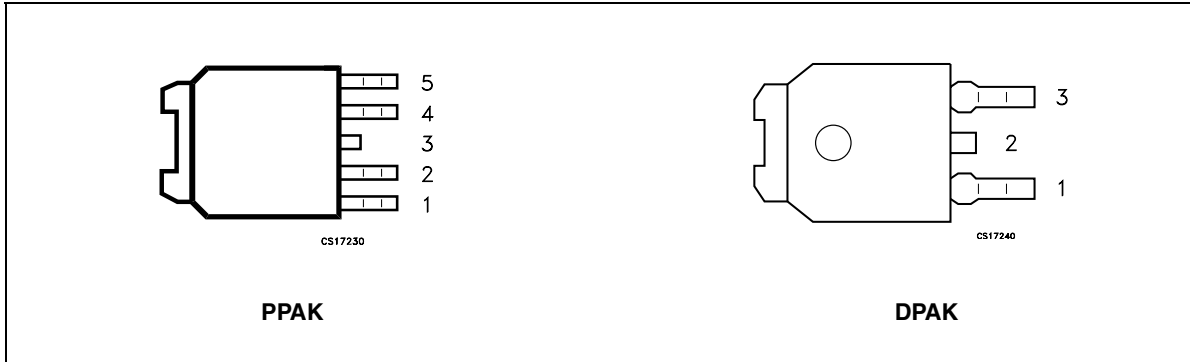

Table 2. Pin description

Symbol	PPAK	DPAK
V_I	2	1
GND	3	2
V_O	4	3
ADJ/N.C. (1)	5	
INHIBIT (2)	1	

1. Not connect for fixed version.

2. Not internally pulled up; in order to assure the operating condition (device in ON mode), it must be connected to a positive voltage higher than 2 V.

Figure 4. Application circuit

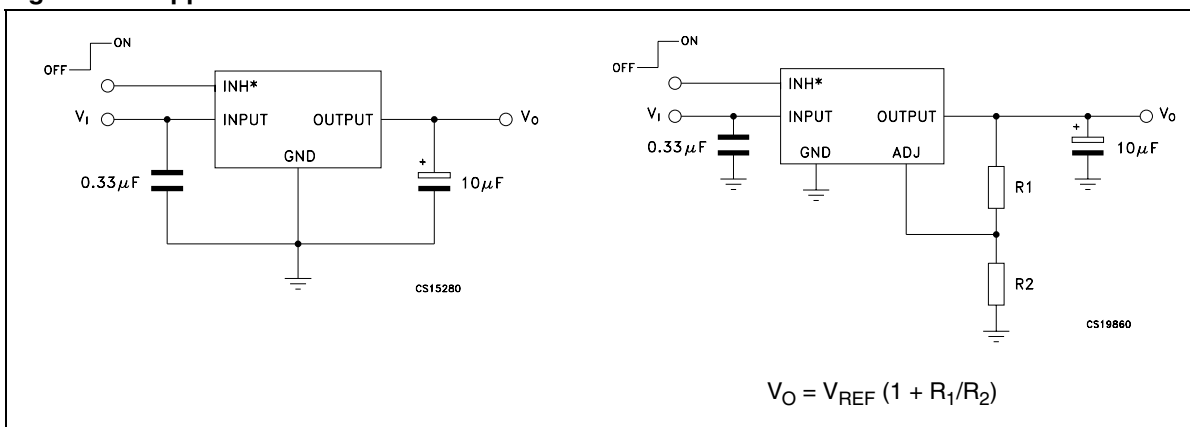

* Only for version with inhibit function.

3 Maximum ratings

Table 3. Absolute maximum ratings

Symbol	Parameter	Value	Unit
V_I	DC input voltage	30 ⁽¹⁾	V
V_{INH}	Inhibit input voltage	14	V
I_O	Output current	Internally limited	mA
P_D	Power dissipation	Internally limited	mW
T_{STG}	Storage temperature range	- 55 to 150	°C
T_{OP}	Operating temperature range	- 40 to 125	°C

1. Above 14 V the device is automatically in shut-down.

Note: Absolute maximum ratings are those values beyond which damage to the device may occur. Functional operation under these conditions is not implied.

Table 4. Thermal data

Symbol	Parameter	DPAK	PPAK	Unit
R_{thJC}	Thermal resistance junction-case	8	8	°C/W
R_{thJA}	Thermal resistance junction-ambient	100	100	°C/W

4 Electrical characteristics

Table 5. Electrical characteristics of LD29080#15

$I_O = 10 \text{ mA}$, (*Note 4*) $T_J = 25 \text{ }^\circ\text{C}$, $V_I = 3.5 \text{ V}$, $V_{INH} = 2\text{V}$, $C_I = 330 \text{ nF}$, $C_O = 10 \text{ } \mu\text{F}$, unless otherwise specified)

Symbol	Parameter	Test conditions	Min.	Typ.	Max.	Unit
V_I	Operating input voltage	$I_O = 10\text{mA}$ to 800mA	2.5		13	V
V_O	Output voltage	$I_O = 10\text{mA}$ to 800mA , $V_I = 3$ to 7V $T_J = -40$ to 125°C	1.485 1.463	1.5	1.515 1.537	V
ΔV_O	Load regulation	$I_O = 10\text{mA}$ to 800mA		0.2	1.0	%
ΔV_O	Line regulation	$V_I = 3$ to 13V		0.06	0.5	%
SVR	Supply voltage rejection	$f = 120 \text{ Hz}$, $V_I = 3.8 \pm 1\text{V}$, $I_O = 400\text{mA}$ (<i>Note 1</i>)	65	75		dB
I_q	Quiescent current	$I_O = 10\text{mA}$, $T_J = -40$ to 125°C		2	5	mA
		$I_O = 400\text{mA}$, $T_J = -40$ to 125°C		8	20	
		$I_O = 800\text{mA}$, $T_J = -40$ to 125°C		14	35	
		$V_I = 13\text{V}$, $V_{INH} = \text{GND}$, $T_J = -40$ to 125°C		130	180	μA
I_{sc}	Short circuit current	$R_L = 0$		1.2		A
V_{IL}	Control input logic low	OFF MODE, $T_J = -40$ to 125°C			0.8	V
V_{IH}	Control input logic high	ON MODE, $T_J = -40$ to 125°C	2			V
I_{INH}	Control input current	$V_{INH} = 13\text{V}$, $T_J = -40$ to 125°C		5	10	μA
eN	Output noise voltage	$B_P = 10\text{Hz}$ to 100kHz , $I_O = 100\text{mA}$		60		μV_{RMS}

Note: 1 Guaranteed by design.

2 Dropout voltage is defined as the input-to-output differential when the output voltage drops to 99 % of its nominal value with $V_O + 1 \text{ V}$ applied to V_I .

3 Reference voltage is measured between output and GND pins, with ADJ PIN tied to V_O .

4 In order to avoid any output voltage rise within the whole operating temperature range, due to output leakage current, a minimum load current of 2 mA is required.

Table 6. Electrical characteristics of LD29080#18

$I_O = 10 \text{ mA}$, (*Note 4*) $T_J = 25 \text{ }^\circ\text{C}$, $V_I = 3.5 \text{ V}$, $V_{INH} = 2 \text{ V}$, $C_I = 330 \text{ nF}$, $C_O = 10 \text{ } \mu\text{F}$, unless otherwise specified)

Symbol	Parameter	Test conditions	Min.	Typ.	Max.	Unit
V_I	Operating input voltage	$I_O = 10\text{mA}$ to 800mA	2.5		13	V
V_O	Output voltage	$I_O = 10\text{mA}$ to 800mA , $V_I = 3$ to 7.3V $T_J = -40$ to 125°C	1.782 1.755	1.8	1.818 1.845	V
ΔV_O	Load regulation	$I_O = 10\text{mA}$ to 800mA		0.2	1.0	%
ΔV_O	Line regulation	$V_I = 3$ to 13V		0.06	0.5	%
SVR	Supply voltage rejection	$f = 120 \text{ Hz}$, $V_I = 3.8 \pm 1\text{V}$, $I_O = 400\text{mA}$ (<i>Note 1</i>)	62	72		dB
V_{DROP}	Dropout voltage	$I_O = 150\text{mA}$, $T_J = -40$ to 125°C (<i>Note 2</i>)		0.1		V
		$I_O = 400\text{mA}$, $T_J = -40$ to 125°C (<i>Note 2</i>)		0.2		
		$I_O = 800\text{mA}$, $T_J = -40$ to 125°C (<i>Note 2</i>)		0.4	0.7	
I_q	Quiescent current	$I_O = 10\text{mA}$, $T_J = -40$ to 125°C		2	5	mA
		$I_O = 400\text{mA}$, $T_J = -40$ to 125°C		8	20	
		$I_O = 800\text{mA}$, $T_J = -40$ to 125°C		14	35	
		$V_I = 13\text{V}$, $V_{INH} = \text{GND}$, $T_J = -40$ to 125°C		130	180	μA
I_{sc}	Short circuit current	$R_L = 0$		1.2		A
V_{IL}	Control input logic low	OFF MODE, $T_J = -40$ to 125°C			0.8	V
V_{IH}	Control input logic high	ON MODE, $T_J = -40$ to 125°C	2			V
I_{INH}	Control input current	$V_{\text{INH}} = 13\text{V}$, $T_J = -40$ to 125°C		5	10	μA
eN	Output noise voltage	$B_P = 10\text{Hz}$ to 100kHz , $I_O = 100\text{mA}$		72		μV_{RMS}

- Note: 1 Guaranteed by design.
 2 Dropout voltage is defined as the input-to-output differential when the output voltage drops to 99 % of its nominal value with $V_O + 1 \text{ V}$ applied to V_I .
 3 Reference voltage is measured between output and GND pins, with ADJ PIN tied to V_O .
 4 In order to avoid any output voltage rise within the whole operating temperature range, due to output leakage current, a minimum load current of 2 mA is required.

Table 7. Electrical characteristics of LD29080#25

$I_O = 10 \text{ mA}$, (*Note 4*) $T_J = 25 \text{ }^\circ\text{C}$, $V_I = 4.5 \text{ V}$, $V_{\text{INH}} = 2 \text{ V}$, $C_I = 330 \text{ nF}$, $C_O = 10 \text{ } \mu\text{F}$, unless otherwise specified)

Symbol	Parameter	Test conditions	Min.	Typ.	Max.	Unit
V_I	Operating input voltage	$I_O = 10\text{mA}$ to 800mA			13	V
V_O	Output voltage	$I_O = 10\text{mA}$ to 800mA , $V_I = 3.5$ to 8V $T_J = -40$ to 125°C	2.475	2.5	2.525	V
			2.438		2.562	
ΔV_O	Load regulation	$I_O = 10\text{mA}$ to 800mA		0.2	1.0	%
ΔV_O	Line regulation	$V_I = 3.5$ to 13V		0.06	0.5	%
SVR	Supply voltage rejection	$f = 120 \text{ Hz}$, $V_I = 4.5 \pm 1\text{V}$, $I_O = 400\text{mA}$ (<i>Note 1</i>)	55	70		dB
V_{DROP}	Dropout voltage	$I_O = 150\text{mA}$, $T_J = -40$ to 125°C (<i>Note 2</i>)		0.1		V
		$I_O = 400\text{mA}$, $T_J = -40$ to 125°C (<i>Note 2</i>)		0.2		
		$I_O = 800\text{mA}$, $T_J = -40$ to 125°C (<i>Note 2</i>)		0.4	0.7	
I_q	Quiescent current	$I_O = 10\text{mA}$, $T_J = -40$ to 125°C		2	5	mA
		$I_O = 400\text{mA}$, $T_J = -40$ to 125°C		8	20	
		$I_O = 800\text{mA}$, $T_J = -40$ to 125°C		14	35	
		$V_I = 13\text{V}$, $V_{\text{INH}} = \text{GND}$, $T_J = -40$ to 125°C		130	180	μA
I_{sc}	Short circuit current	$R_L = 0$		1.2		A
V_{IL}	Control input logic low	OFF MODE, $T_J = -40$ to 125°C			0.8	V
V_{IH}	Control input logic high	ON MODE, $T_J = -40$ to 125°C	2			V
I_{INH}	Control input current	$V_{\text{INH}} = 13\text{V}$, $T_J = -40$ to 125°C		5	10	μA
eN	Output noise voltage	$B_P = 10\text{Hz}$ to 100kHz , $I_O = 100\text{mA}$		100		μV_{RMS}

- Note: 1 Guaranteed by design.
- 2 Dropout voltage is defined as the input-to-output differential when the output voltage drops to 99% of its nominal value with $V_O + 1 \text{ V}$ applied to V_I .
- 3 Reference voltage is measured between output and GND pins, with ADJ PIN tied to V_O .
- 4 In order to avoid any output voltage rise within the whole operating temperature range, due to output leakage current, a minimum load current of 2 mA is required.

Table 8. Electrical characteristics of LD29080#33

$I_O = 10 \text{ mA}$, (*Note 4*) $T_J = 25 \text{ }^\circ\text{C}$, $V_I = 5.3 \text{ V}$, $V_{\text{INH}} = 2 \text{ V}$, $C_I = 330 \text{ nF}$, $C_O = 10 \text{ } \mu\text{F}$, unless otherwise specified)

Symbol	Parameter	Test conditions	Min.	Typ.	Max.	Unit
V_I	Operating input voltage	$I_O = 10\text{mA}$ to 800mA			13	V
V_O	Output voltage	$I_O = 10\text{mA}$ to 800mA , $V_I = 4.3$ to 8.8V $T_J = -40$ to 125°C	3.267 3.218	3.3	3.333 3.382	V
ΔV_O	Load regulation	$I_O = 10\text{mA}$ to 800mA		0.2	1.0	%
ΔV_O	Line regulation	$V_I = 4.3$ to 13V		0.06	0.5	%
SVR	Supply voltage rejection	$f = 120 \text{ Hz}$, $V_I = 5.3 \pm 1\text{V}$, $I_O = 400\text{mA}$ (<i>Note 1</i>)	52	67		dB
V_{DROP}	Dropout voltage	$I_O = 150\text{mA}$, $T_J = -40$ to 125°C (<i>Note 2</i>)		0.1		V
		$I_O = 400\text{mA}$, $T_J = -40$ to 125°C (<i>Note 2</i>)		0.2		
		$I_O = 800\text{mA}$, $T_J = -40$ to 125°C (<i>Note 2</i>)		0.4	0.7	
I_q	Quiescent current	$I_O = 10\text{mA}$, $T_J = -40$ to 125°C		2	5	mA
		$I_O = 400\text{mA}$, $T_J = -40$ to 125°C		8	20	
		$I_O = 800\text{mA}$, $T_J = -40$ to 125°C		14	35	
		$V_I = 13\text{V}$, $V_{\text{INH}} = \text{GND}$, $T_J = -40$ to 125°C		130	180	μA
I_{sc}	Short circuit current	$R_L = 0$		1.2		A
V_{IL}	Control input logic low	OFF MODE, $T_J = -40$ to 125°C			0.8	V
V_{IH}	Control input logic high	ON MODE, $T_J = -40$ to 125°C	2			V
I_{INH}	Control input current	$V_{\text{INH}} = 13\text{V}$, $T_J = -40$ to 125°C		5	10	μA
eN	Output noise voltage	$B_P = 10\text{Hz}$ to 100kHz , $I_O = 100\text{mA}$		132		μV_{RMS}

- Note: 1 Guaranteed by design.
- 2 Dropout voltage is defined as the input-to-output differential when the output voltage drops to 99 % of its nominal value with $V_O + 1 \text{ V}$ applied to V_I .
- 3 Reference voltage is measured between output and GND pins, with ADJ PIN tied to V_O .
- 4 In order to avoid any output voltage rise within the whole operating temperature range, due to output leakage current, a minimum load current of 2 mA is required.

Table 9. Electrical characteristics of LD29080#50

$I_O = 10 \text{ mA}$, (*Note 4*) $T_J = 25 \text{ }^\circ\text{C}$, $V_I = 7 \text{ V}$, $V_{INH} = 2 \text{ V}$, $C_I = 330 \text{ nF}$, $C_O = 10 \text{ } \mu\text{F}$, unless otherwise specified)

Symbol	Parameter	Test conditions	Min.	Typ.	Max.	Unit
V_I	Operating input voltage	$I_O = 10\text{mA}$ to 800mA			13	V
V_O	Output voltage	$I_O = 10\text{mA}$ to 800mA , $V_I = 6$ to 10.5V $T_J = -40$ to 125°C	4.95 4.875	5	5.05 5.125	V
ΔV_O	Load regulation	$I_O = 10\text{mA}$ to 800mA		0.2	1.0	%
ΔV_O	Line regulation	$V_I = 6$ to 13V		0.06	0.5	%
SVR	Supply voltage rejection	$f = 120 \text{ Hz}$, $V_I = 7 \pm 1\text{V}$, $I_O = 400\text{mA}$ (<i>Note 1</i>)	49	64		dB
V_{DROP}	Dropout voltage	$I_O = 150\text{mA}$, $T_J = -40$ to 125°C (<i>Note 2</i>)		0.1		V
		$I_O = 400\text{mA}$, $T_J = -40$ to 125°C (<i>Note 2</i>)		0.2		
		$I_O = 800\text{mA}$, $T_J = -40$ to 125°C (<i>Note 2</i>)		0.4	0.7	
I_q	Quiescent current	$I_O = 10\text{mA}$, $T_J = -40$ to 125°C		2	5	mA
		$I_O = 400\text{mA}$, $T_J = -40$ to 125°C		8	20	
		$I_O = 800\text{mA}$, $T_J = -40$ to 125°C		14	35	
		$V_I = 13\text{V}$, $V_{INH} = \text{GND}$, $T_J = -40$ to 125°C		130	180	μA
I_{sc}	Short circuit current	$R_L = 0$		1.2		A
V_{IL}	Control input logic low	OFF MODE, $T_J = -40$ to 125°C			0.8	V
V_{IH}	Control input logic high	ON MODE, $T_J = -40$ to 125°C	2			V
I_{INH}	Control input current	$V_{INH} = 13\text{V}$, $T_J = -40$ to 125°C		5	10	μA
eN	Output noise voltage	$B_P = 10\text{Hz}$ to 100kHz , $I_O = 100\text{mA}$		180		μV_{RMS}

- Note: 1 Guaranteed by design.
- 2 Dropout voltage is defined as the input-to-output differential when the output voltage drops to 99 % of its nominal value with $V_O + 1 \text{ V}$ applied to V_I .
- 3 Reference voltage is measured between output and GND pins, with ADJ PIN tied to V_O .
- 4 In order to avoid any output voltage rise within the whole operating temperature range, due to output leakage current, a minimum load current of 2 mA is required.

Table 10. Electrical characteristics of LD29080#80

$I_O = 10 \text{ mA}$, (*Note 4*) $T_J = 25 \text{ }^\circ\text{C}$, $V_I = 10 \text{ V}$, $V_{\text{INH}} = 2 \text{ V}$, $C_I = 330 \text{ nF}$, $C_O = 10 \text{ } \mu\text{F}$, unless otherwise specified)

Symbol	Parameter	Test conditions	Min.	Typ.	Max.	Unit
V_I	Operating input voltage	$I_O = 10\text{mA}$ to 800mA			13	V
V_O	Output voltage	$I_O = 10\text{mA}$ to 800mA , $V_I = 9$ to 13V $T_J = -40$ to 125°C	7.92	8	8.08	V
			7.80		8.20	
ΔV_O	Load regulation	$I_O = 10\text{mA}$ to 800mA		0.2	1.0	%
ΔV_O	Line regulation	$V_I = 9$ to 13V		0.06	0.5	%
SVR	Supply voltage rejection	$f = 120 \text{ Hz}$, $V_I = 10 \pm 1\text{V}$, $I_O = 400\text{mA}$ (<i>Note 1</i>)	45	59		dB
V_{DROP}	Dropout voltage	$I_O = 150\text{mA}$, $T_J = -40$ to 125°C (<i>Note 2</i>)		0.1		V
		$I_O = 400\text{mA}$, $T_J = -40$ to 125°C (<i>Note 2</i>)		0.2		
		$I_O = 800\text{mA}$, $T_J = -40$ to 125°C (<i>Note 2</i>)		0.4	0.7	
I_q	Quiescent current	$I_O = 10\text{mA}$, $T_J = -40$ to 125°C		2	5	mA
		$I_O = 400\text{mA}$, $T_J = -40$ to 125°C		8	20	
		$I_O = 800\text{mA}$, $T_J = -40$ to 125°C		14	35	
		$V_I = 13\text{V}$, $V_{\text{INH}} = \text{GND}$, $T_J = -40$ to 125°C		130	180	μA
I_{sc}	Short circuit current	$R_L = 0$		1.2		A
V_{IL}	Control input logic low	OFF MODE, $T_J = -40$ to 125°C			0.8	V
V_{IH}	Control input logic high	ON MODE, $T_J = -40$ to 125°C	2			V
I_{INH}	Control input current	$V_{\text{INH}} = 13\text{V}$, $T_J = -40$ to 125°C		5	10	μA
eN	Output noise voltage	$B_P = 10\text{Hz}$ to 100kHz , $I_O = 100\text{mA}$		320		μV_{RMS}

- Note:*
- 1 Guaranteed by design.
 - 2 Dropout voltage is defined as the input-to-output differential when the output voltage drops to 99 % of its nominal value with $V_O + 1 \text{ V}$ applied to V_I .
 - 3 Reference voltage is measured between output and GND pins, with ADJ PIN tied to V_O .
 - 4 In order to avoid any output voltage rise within the whole operating temperature range, due to output leakage current, a minimum load current of 2 mA is required.

Table 11. Electrical characteristics of LD29080#90

$I_O = 10 \text{ mA}$, (*Note 4*) $T_J = 25 \text{ }^\circ\text{C}$, $V_I = 11 \text{ V}$, $V_{INH} = 2 \text{ V}$, $C_I = 330 \text{ nF}$, $C_O = 10 \text{ } \mu\text{F}$, unless otherwise specified)

Symbol	Parameter	Test conditions	Min.	Typ.	Max.	Unit
V_I	Operating input voltage	$I_O = 10\text{mA}$ to 800mA			13	V
V_O	Output voltage	$I_O = 10\text{mA}$ to 800mA , $V_I = 9$ to 13V $T_J = -40$ to 125°C	8.91	9	9.09	V
			8.775		9.225	
ΔV_O	Load regulation	$I_O = 10\text{mA}$ to 800mA		0.2	1.0	%
ΔV_O	Line regulation	$V_I = 10$ to 13V		0.06	0.5	%
SVR	Supply voltage rejection	$f = 120 \text{ Hz}$, $V_I = 11 \pm 1\text{V}$, $I_O = 400\text{mA}$ (<i>Note 1</i>)	43	57		dB
V_{DROPO}	Dropout voltage	$I_O = 150\text{mA}$, $T_J = -40$ to 125°C (<i>Note 2</i>)		0.1		V
		$I_O = 400\text{mA}$, $T_J = -40$ to 125°C (<i>Note 2</i>)		0.2		
		$I_O = 800\text{mA}$, $T_J = -40$ to 125°C (<i>Note 2</i>)		0.4	0.7	
I_q	Quiescent current	$I_O = 10\text{mA}$, $T_J = -40$ to 125°C		2	5	mA
		$I_O = 400\text{mA}$, $T_J = -40$ to 125°C		8	20	
		$I_O = 800\text{mA}$, $T_J = -40$ to 125°C		14	35	
		$V_I = 13\text{V}$, $V_{INH} = \text{GND}$, $T_J = -40$ to 125°C		130	180	μA
I_{sc}	Short circuit current	$R_L = 0$		1.2		A
V_{IL}	Control input logic low	OFF MODE, $T_J = -40$ to 125°C			0.8	V
V_{IH}	Control input logic high	ON MODE, $T_J = -40$ to 125°C	2			V
I_{INH}	Control input current	$V_{INH} = 13\text{V}$, $T_J = -40$ to 125°C		5	10	μA
eN	Output noise voltage	$B_P = 10\text{Hz}$ to 100kHz , $I_O = 100\text{mA}$		330		μV_{RMS}

- Note:*
- 1 Guaranteed by design.
 - 2 Dropout voltage is defined as the input-to-output differential when the output voltage drops to 99 % of its nominal value with $V_O + 1 \text{ V}$ applied to V_I .
 - 3 Reference voltage is measured between output and GND pins, with ADJ PIN tied to V_O .
 - 4 In order to avoid any output voltage rise within the whole operating temperature range, due to output leakage current, a minimum load current of 2 mA is required.

Table 12. Electrical characteristics of LD29080#ADJ

$I_O = 10 \text{ mA}$, (*Note 4*) $T_J = 25 \text{ }^\circ\text{C}$, $V_I = 10 \text{ V}$, $V_{INH} = 2 \text{ V}$, $C_I = 330 \text{ nF}$, $C_O = 10 \text{ } \mu\text{F}$, unless otherwise specified)

Symbol	Parameter	Test conditions	Min.	Typ.	Max.	Unit
V_I	Operating input voltage	$I_O = 10\text{mA}$ to 800mA	2.5		13	V
ΔV_O	Load regulation	$I_O = 10\text{mA}$ to 800mA		0.2	1.0	%
ΔV_O	Line regulation	$V_I = 2.5$ to 13V , $I_O = 10\text{mA}$		0.06	0.5	%
V_{REF}	Reference voltage	$I_O = 10\text{mA}$ to 800mA , $V_I = 2.5$ to 6.73V $T_J = -40$ to 125°C (<i>Note 3</i>)	1.2177	1.23	1.2423	V
			1.1993		1.2607	
SVR	Supply voltage rejection	$f = 120 \text{ Hz}$, $V_I = 3.23 \pm 1\text{V}$, $I_O = 400\text{mA}$ (<i>Note 1</i>)	45	75		dB
I_q	Quiescent current	$I_O = 10\text{mA}$, $T_J = -40$ to 125°C		2	5	mA
		$I_O = 400\text{mA}$, $T_J = -40$ to 125°C		8	20	
		$I_O = 800\text{mA}$, $T_J = -40$ to 125°C		14	35	
		$V_I = 13\text{V}$, $V_{INH} = \text{GND}$, $T_J = -40$ to 125°C		130	180	μA
I_{ADJ}	Adjust pin current	$T_J = -40$ to 125°C			1	μA
I_{sc}	Short circuit current	$R_L = 0$		1.2		A
V_{IL}	Control input logic low	OFF MODE, $T_J = -40$ to 125°C			0.8	V
V_{IH}	Control input logic high	ON MODE, $T_J = -40$ to 125°C	2			V
I_{INH}	Control input current	$V_{INH} = 13\text{V}$, $T_J = -40$ to 125°C		5	10	μA
eN	Output noise voltage	$B_p = 10\text{Hz}$ to 100kHz , $I_O = 100\text{mA}$		50		μV_{RMS}

Note: 1 Guaranteed by design.

2 Dropout voltage is defined as the input-to-output differential when the output voltage drops to 99 % of its nominal value with $V_O + 1 \text{ V}$ applied to V_I .

3 Reference voltage is measured between output and GND pins, with ADJ PIN tied to V_O .

4 In order to avoid any output voltage rise within the whole operating temperature range, due to output leakage current, a minimum load current of 2 mA is required.

5 Typical characteristics

Figure 5. Output voltage vs temperature

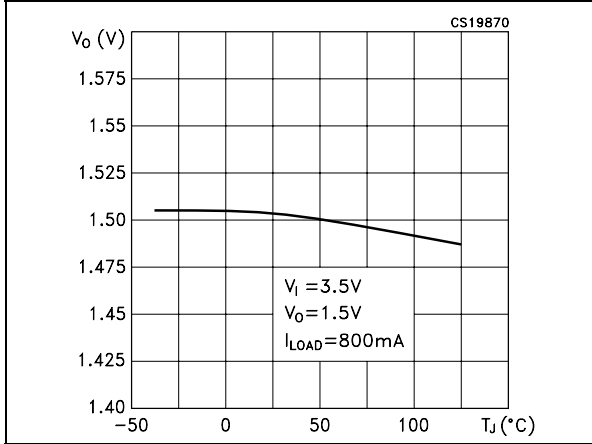

Figure 6. Reference voltage vs temperature

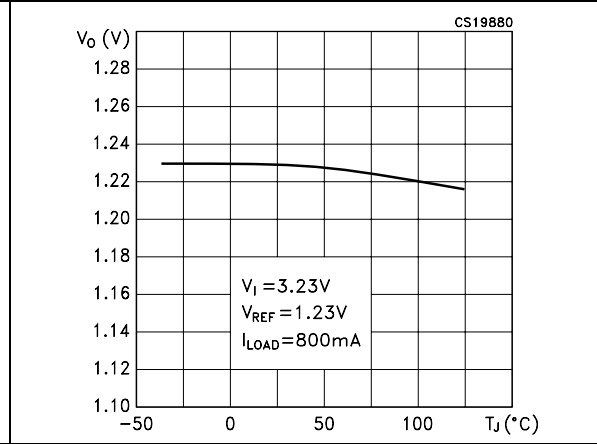

Figure 7. Dropout voltage vs temperature

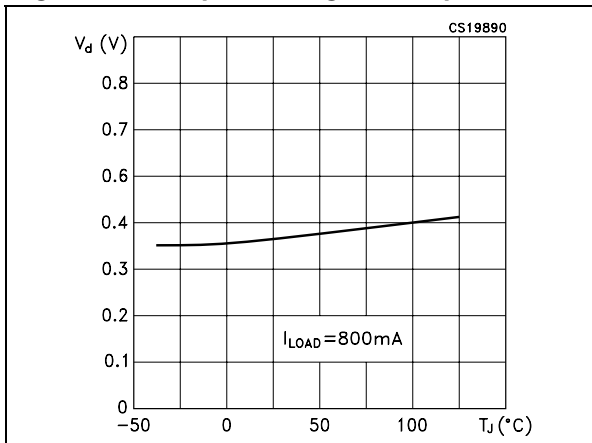

Figure 8. Dropout voltage vs output current

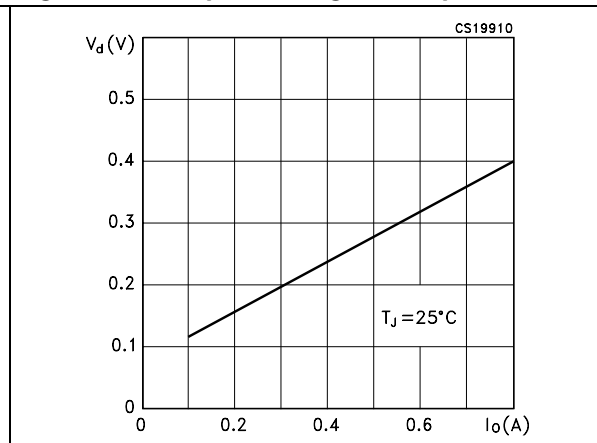

Figure 9. Quiescent current vs output current

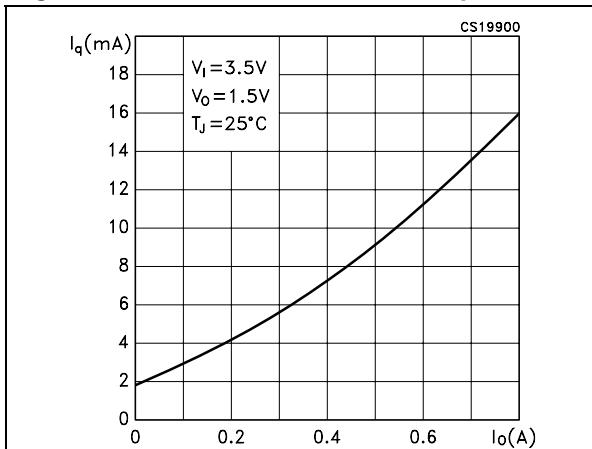

Figure 10. Quiescent current vs temperature

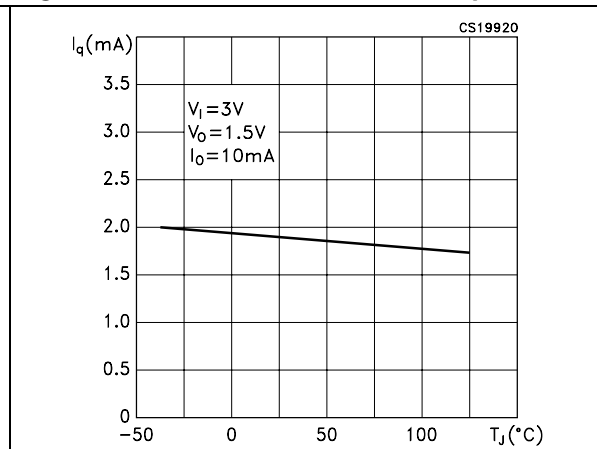

Figure 11. Quiescent current vs supply voltage

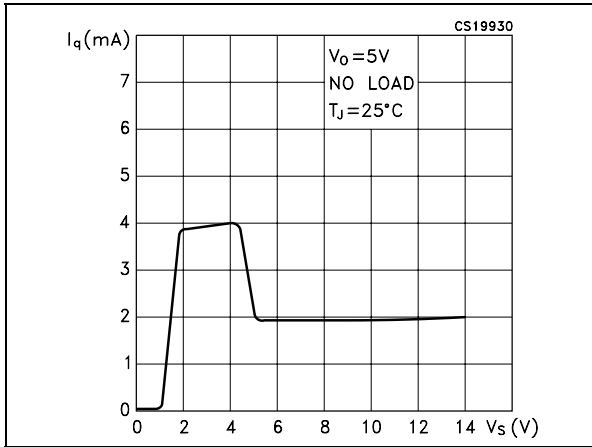

Figure 12. Quiescent current vs temperature

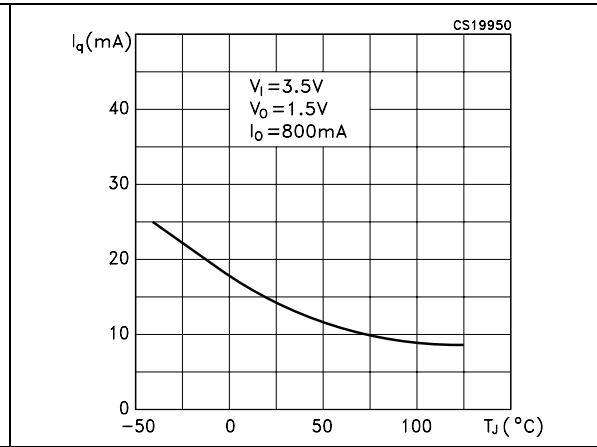

Figure 13. Short circuit current vs temperature

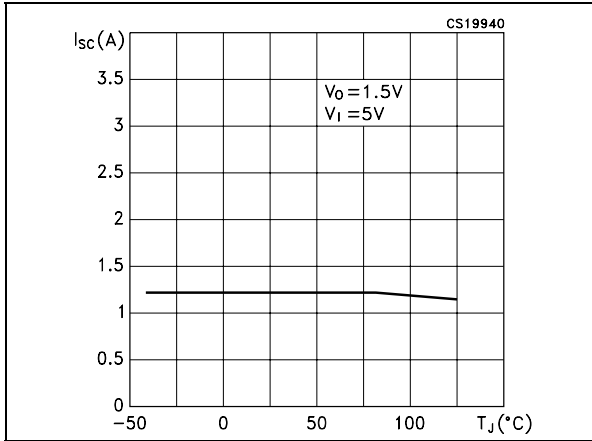

Figure 14. Adjust pin current vs temperature

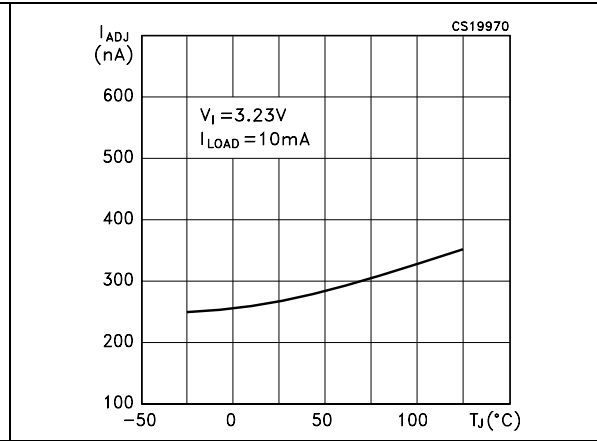

Figure 15. Supply voltage rejection vs temperature

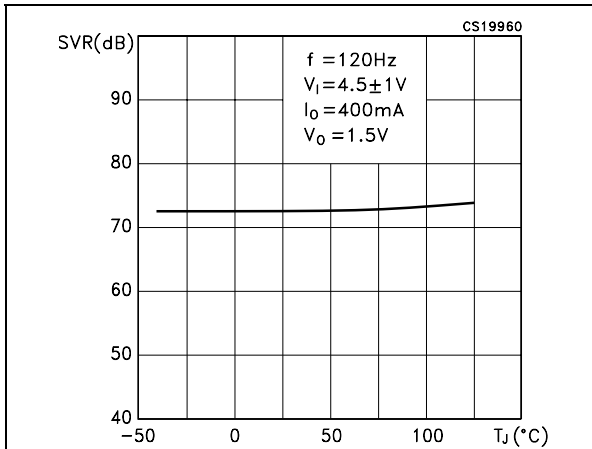

Figure 16. Output voltage vs input voltage

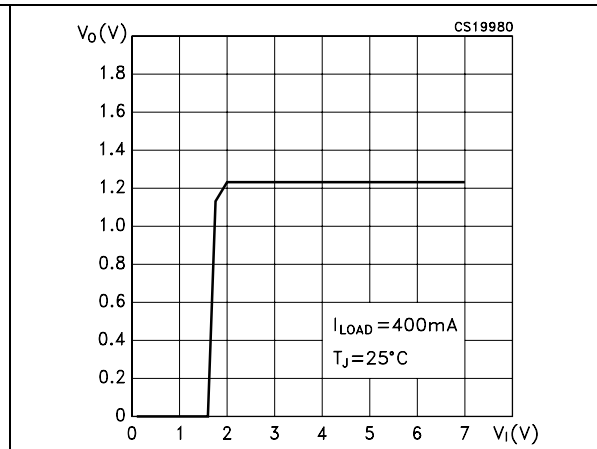

Figure 17. Stability vs C_O

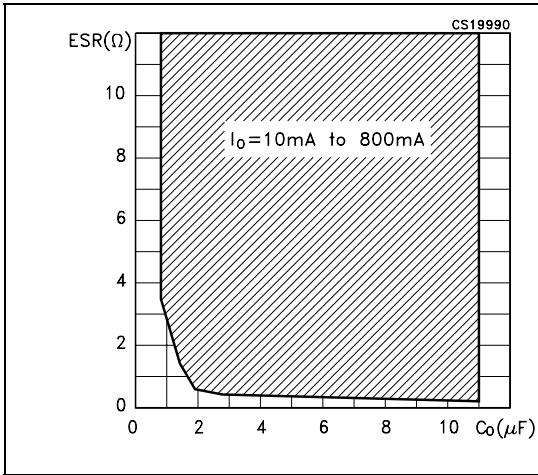

Figure 18. Line transient

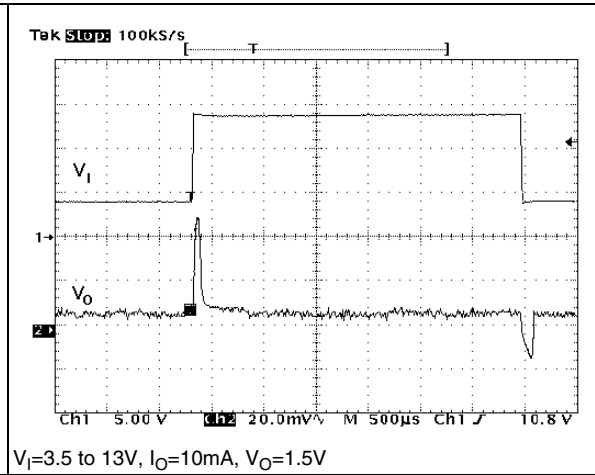
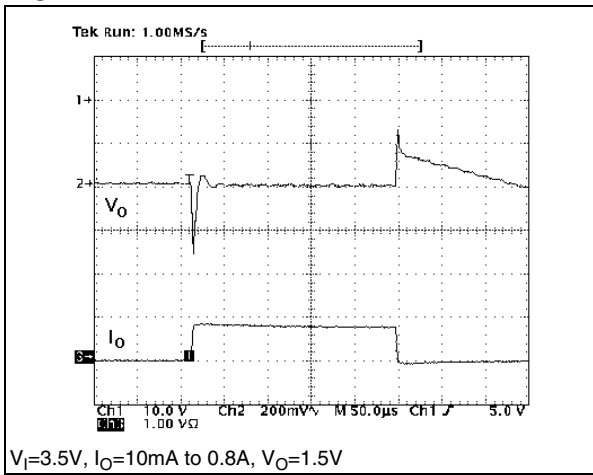

Figure 19. Load transient



6 Package mechanical data

In order to meet environmental requirements, ST offers these devices in different grades of ECOPACK® packages, depending on their level of environmental compliance. ECOPACK® specifications, grade definitions and product status are available at: www.st.com. ECOPACK® is an ST trademark.

PPAK mechanical data

Dim.	mm.			inch.		
	Min.	Typ.	Max.	Min.	Typ.	Max.
A	2.2		2.4	0.086		0.094
A1	0.9		1.1	0.035		0.043
A2	0.03		0.23	0.001		0.009
B	0.4		0.6	0.015		0.023
B2	5.2		5.4	0.204		0.212
C	0.45		0.6	0.017		0.023
C2	0.48		0.6	0.019		0.023
D	6		6.2	0.236		0.244
D1		5.1			0.201	
E	6.4		6.6	0.252		0.260
E1		4.7			0.185	
e		1.27			0.050	
G	4.9		5.25	0.193		0.206
G1	2.38		2.7	0.093		0.106
H	9.35		10.1	0.368		0.397
L2		0.8	1		0.031	0.039
L4	0.6		1	0.023		0.039
L5	1			0.039		
L6		2.8			0.110	

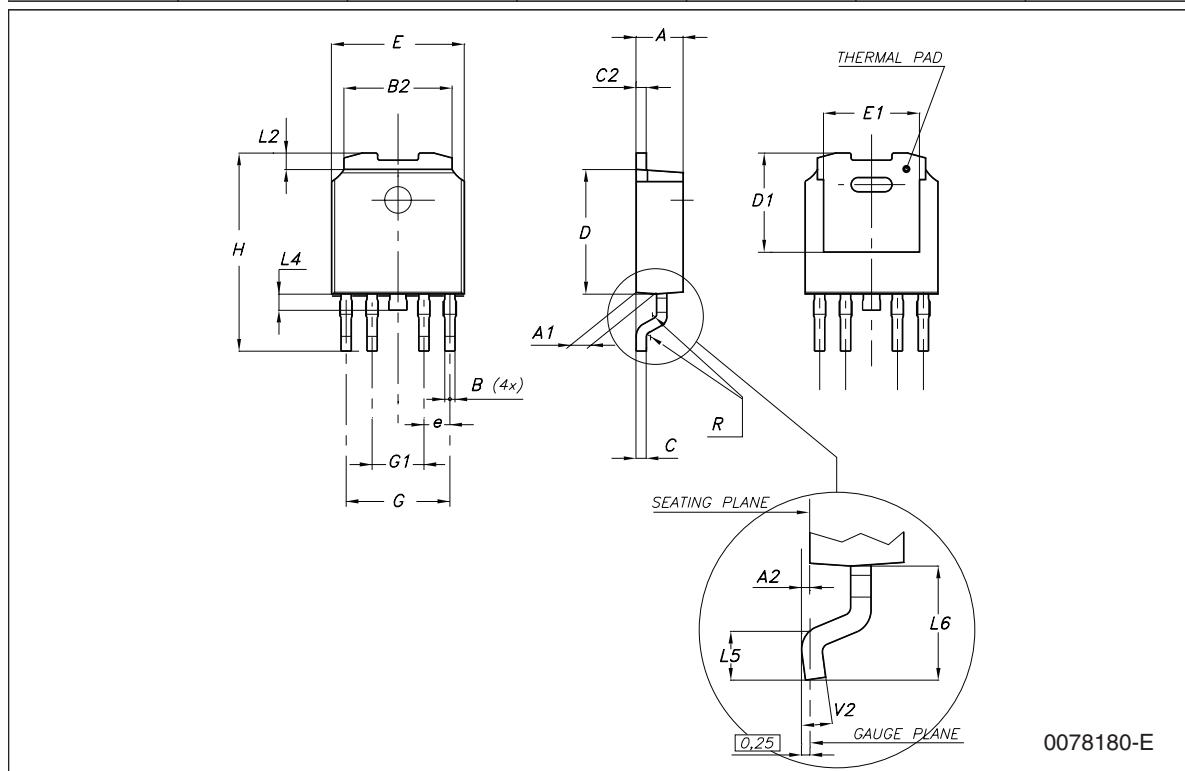

0078180-E

DPAK mechanical data

Dim.	mm.			inch.		
	Min.	Typ.	Max.	Min.	Typ.	Max.
A	2.2		2.4	0.086		0.094
A1	0.9		1.1	0.035		0.043
A2	0.03		0.23	0.001		0.009
B	0.64		0.9	0.025		0.035
b4	5.2		5.4	0.204		0.212
C	0.45		0.6	0.017		0.023
C2	0.48		0.6	0.019		0.023
D	6		6.2	0.236		0.244
D1		5.1			0.200	
E	6.4		6.6	0.252		0.260
E1		4.7			0.185	
e		2.28			0.090	
e1	4.4		4.6	0.173		0.181
H	9.35		10.1	0.368		0.397
L	1			0.039		
(L1)		2.8			0.110	
L2		0.8			0.031	
L4	0.6		1	0.023		0.039
R		0.2			0.008	
V2	0°		8°	0°		8°

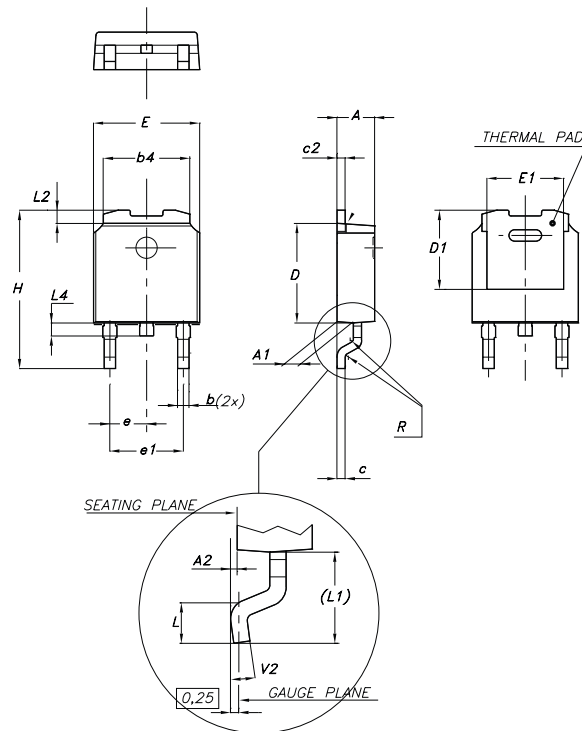

0068772-F

Tape & reel DPAK-PPAK mechanical data

Dim.	mm.			inch.		
	Min.	Typ.	Max.	Min.	Typ.	Max.
A			330			12.992
C	12.8	13.0	13.2	0.504	0.512	0.519
D	20.2			0.795		
N	60			2.362		
T			22.4			0.882
Ao	6.80	6.90	7.00	0.268	0.272	0.276
Bo	10.40	10.50	10.60	0.409	0.413	0.417
Ko	2.55	2.65	2.75	0.100	0.104	0.105
Po	3.9	4.0	4.1	0.153	0.157	0.161
P	7.9	8.0	8.1	0.311	0.315	0.319

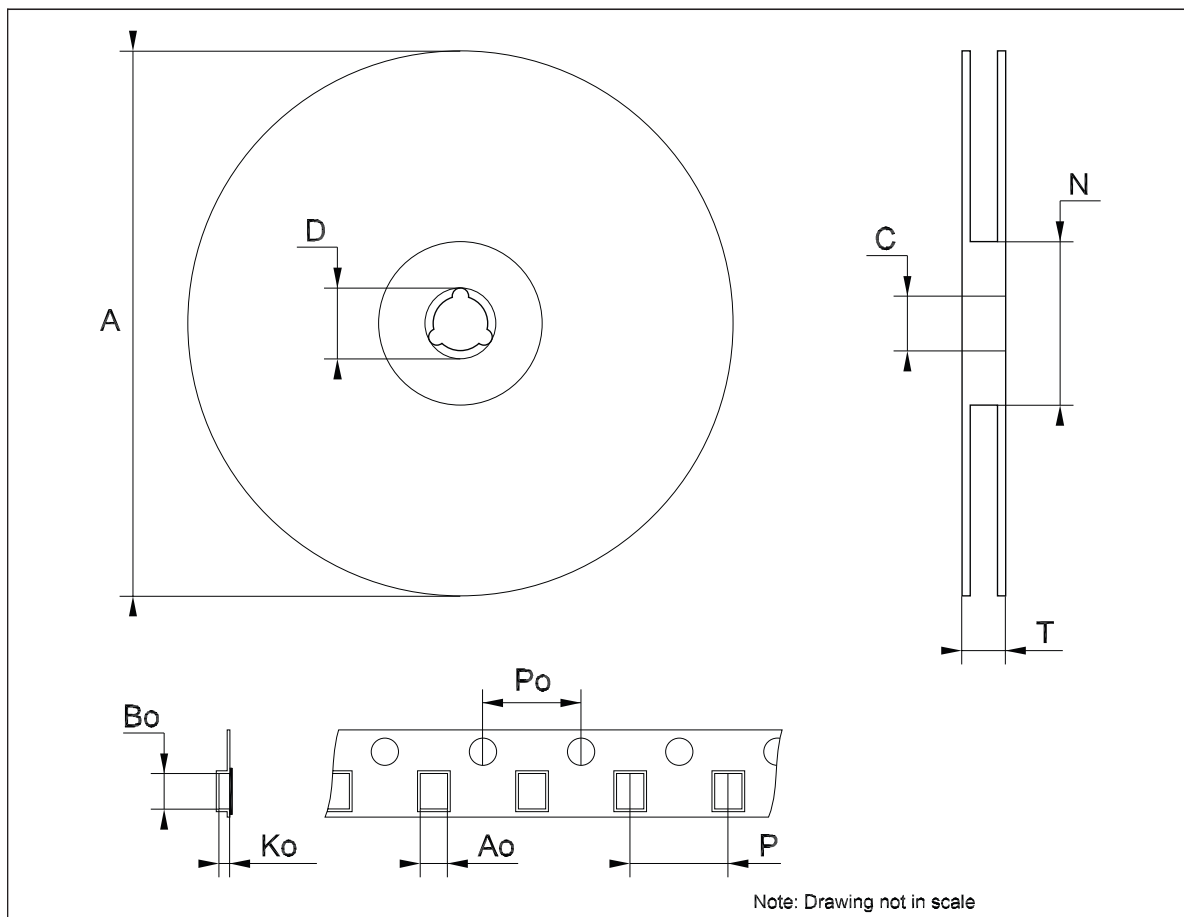

7 Revision history

Table 13. Document revision history

Date	Revision	Changes
15-Oct-2004	1	First release.
20-Oct-2005	2	Order codes updated.
14-May-2007	3	Order codes updated.
26-Jan-2009	4	Modified: eN value in Table 9 on page 10 .

Please Read Carefully:

Information in this document is provided solely in connection with ST products. STMicroelectronics NV and its subsidiaries ("ST") reserve the right to make changes, corrections, modifications or improvements, to this document, and the products and services described herein at any time, without notice.

All ST products are sold pursuant to ST's terms and conditions of sale.

Purchasers are solely responsible for the choice, selection and use of the ST products and services described herein, and ST assumes no liability whatsoever relating to the choice, selection or use of the ST products and services described herein.

No license, express or implied, by estoppel or otherwise, to any intellectual property rights is granted under this document. If any part of this document refers to any third party products or services it shall not be deemed a license grant by ST for the use of such third party products or services, or any intellectual property contained therein or considered as a warranty covering the use in any manner whatsoever of such third party products or services or any intellectual property contained therein.

UNLESS OTHERWISE SET FORTH IN ST'S TERMS AND CONDITIONS OF SALE ST DISCLAIMS ANY EXPRESS OR IMPLIED WARRANTY WITH RESPECT TO THE USE AND/OR SALE OF ST PRODUCTS INCLUDING WITHOUT LIMITATION IMPLIED WARRANTIES OF MERCHANTABILITY, FITNESS FOR A PARTICULAR PURPOSE (AND THEIR EQUIVALENTS UNDER THE LAWS OF ANY JURISDICTION), OR INFRINGEMENT OF ANY PATENT, COPYRIGHT OR OTHER INTELLECTUAL PROPERTY RIGHT.

UNLESS EXPRESSLY APPROVED IN WRITING BY AN AUTHORIZED ST REPRESENTATIVE, ST PRODUCTS ARE NOT RECOMMENDED, AUTHORIZED OR WARRANTED FOR USE IN MILITARY, AIR CRAFT, SPACE, LIFE SAVING, OR LIFE SUSTAINING APPLICATIONS, NOR IN PRODUCTS OR SYSTEMS WHERE FAILURE OR MALFUNCTION MAY RESULT IN PERSONAL INJURY, DEATH, OR SEVERE PROPERTY OR ENVIRONMENTAL DAMAGE. ST PRODUCTS WHICH ARE NOT SPECIFIED AS "AUTOMOTIVE GRADE" MAY ONLY BE USED IN AUTOMOTIVE APPLICATIONS AT USER'S OWN RISK.

Resale of ST products with provisions different from the statements and/or technical features set forth in this document shall immediately void any warranty granted by ST for the ST product or service described herein and shall not create or extend in any manner whatsoever, any liability of ST.

ST and the ST logo are trademarks or registered trademarks of ST in various countries.

Information in this document supersedes and replaces all information previously supplied.

The ST logo is a registered trademark of STMicroelectronics. All other names are the property of their respective owners.

© 2009 STMicroelectronics - All rights reserved

STMicroelectronics group of companies

Australia - Belgium - Brazil - Canada - China - Czech Republic - Finland - France - Germany - Hong Kong - India - Israel - Italy - Japan - Malaysia - Malta - Morocco - Singapore - Spain - Sweden - Switzerland - United Kingdom - United States of America

www.st.com