

3A, VERY LOW DROP VOLTAGE REGULATORS

- VERY LOW DROPOUT VOLTAGE (TYP. 0.4 AT 3A)
- GUARANTEED OUTPUT CURRENT UP TO 3A
- FIXED VOLTAGE WITH $\pm 1\%$ TOLERANCE AT 25°C
- INTERNAL CURRENT AND THERMAL LIMIT
- LOGIC CONTROLLED ELECTRONIC SHUTDOWN AVAILABLE IN PPAK

DESCRIPTION

The LD29300 is a high current, high accuracy, low-dropout voltage regulator series. These regulators feature 400mV dropout voltage and very low ground current. Designed for high current loads, these devices are also used in lower current, extremely low dropout-critical systems, where their tiny dropout voltage and ground current values are important attributes. Typical applications are in Power supply switching post regulation, Series power supply for monitors, Series power supply for VCRs and TVs, Computer Systems and Battery powered systems.

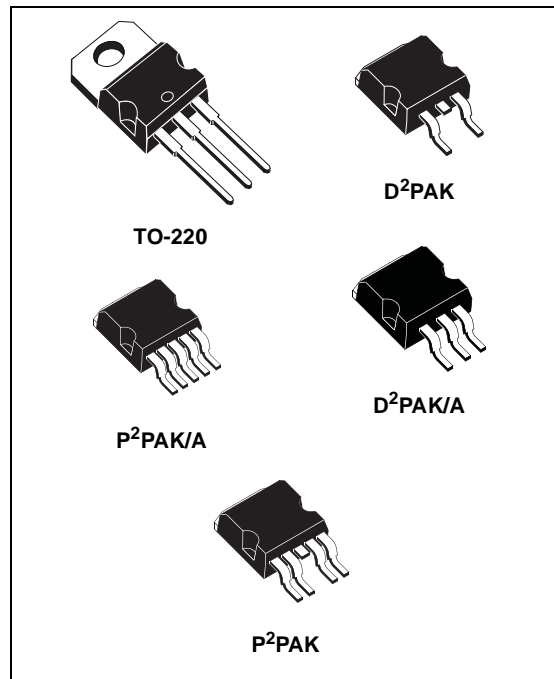

SCHEMATIC DIAGRAM FOR ADJUSTABLE VERSION

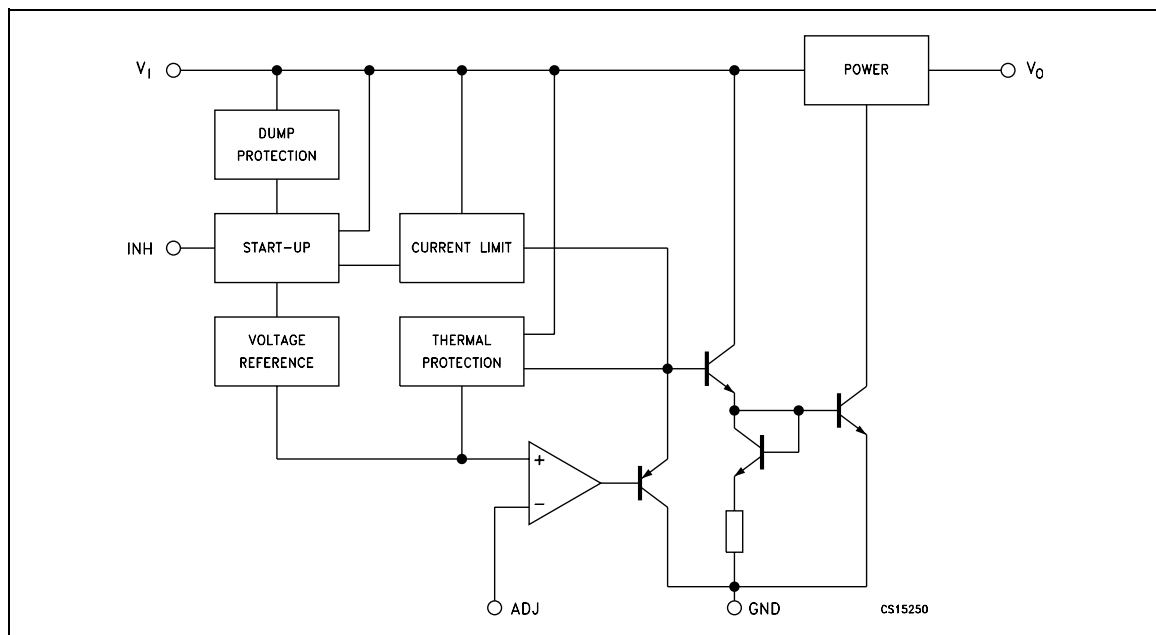

LD29300 SERIES

SCHEMATIC DIAGRAM FOR FIXED VERSION

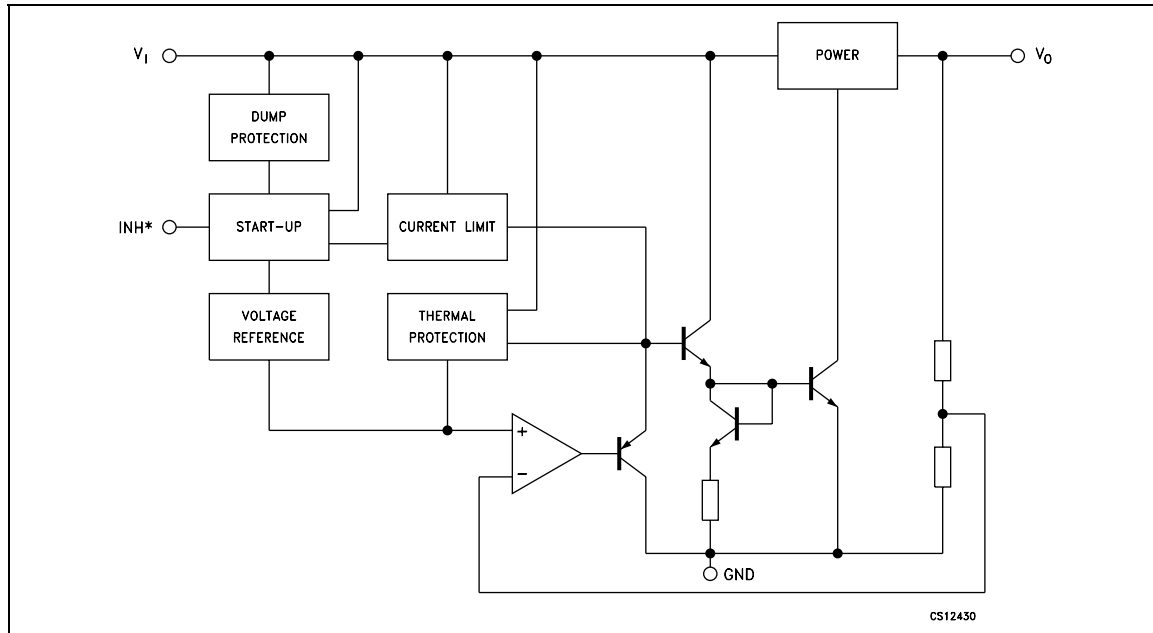

* Only for version with inhibit function.

ORDERING CODES

TO-220	D ² PAK (*)	D ² PAK/A (*)	P ² PAK (*) (#)	P ² PAK/A (*)	OUTPUT VOLTAGE
LD29300V15	LD29300D2T15	LD29300D2M15	LD29300P2T15	LD29300P2M15	1.5 V
LD29300V18	LD29300D2T18	LD29300D2M18	LD29300P2T18	LD29300P2M18	1.8 V
LD29300V25	LD29300D2T25	LD29300D2M25	LD29300P2T25	LD29300P2M25	2.5 V
LD29300V33	LD29300D2T33	LD29300D2M33	LD29300P2T33	LD29300P2M33	3.3 V
LD29300V50	LD29300D2T50	LD29300D2M50	LD29300P2T50	LD29300P2M50	5.0 V
LD29300V80	LD29300D2T80	LD29300D2M80	LD29300P2T80	LD29300P2M80	8.0 V
LD29300V90	LD29300D2T90	LD29300D2M90	LD29300P2T90	LD29300P2M90	9.0 V
			LD29300P2T	LD29300P2M	ADJ

(*) Available in Tape & Reel with the suffix "R".

(#) Available on request.

ABSOLUTE MAXIMUM RATINGS

Symbol	Parameter	Value	Unit
V _I	DC Input Voltage	30 (*)	V
I _O	Output Current	Internally Limited	mA
P _D	Power Dissipation	Internally Limited	mW
T _{stg}	Storage Temperature Range	-55 to 150	°C
T _{op}	Operating Junction Temperature Range	-40 to 125	°C

(*) Above 14V the device is automatically in shut-down.

Absolute Maximum Ratings are those beyond which damage to the device may occur. Functional operation under these condition is not implied.

THERMAL DATA

Symbol	Parameter	TO-220	D ² PAK-P ² PAK D ² PAK/A-P ² PAK/A	Unit
R _{thj-case}	Thermal Resistance Junction-case	3	3	°C/W
R _{thj-amb}	Thermal Resistance Junction-ambient	50	60	°C/W

CONNECTION DIAGRAM (top view)

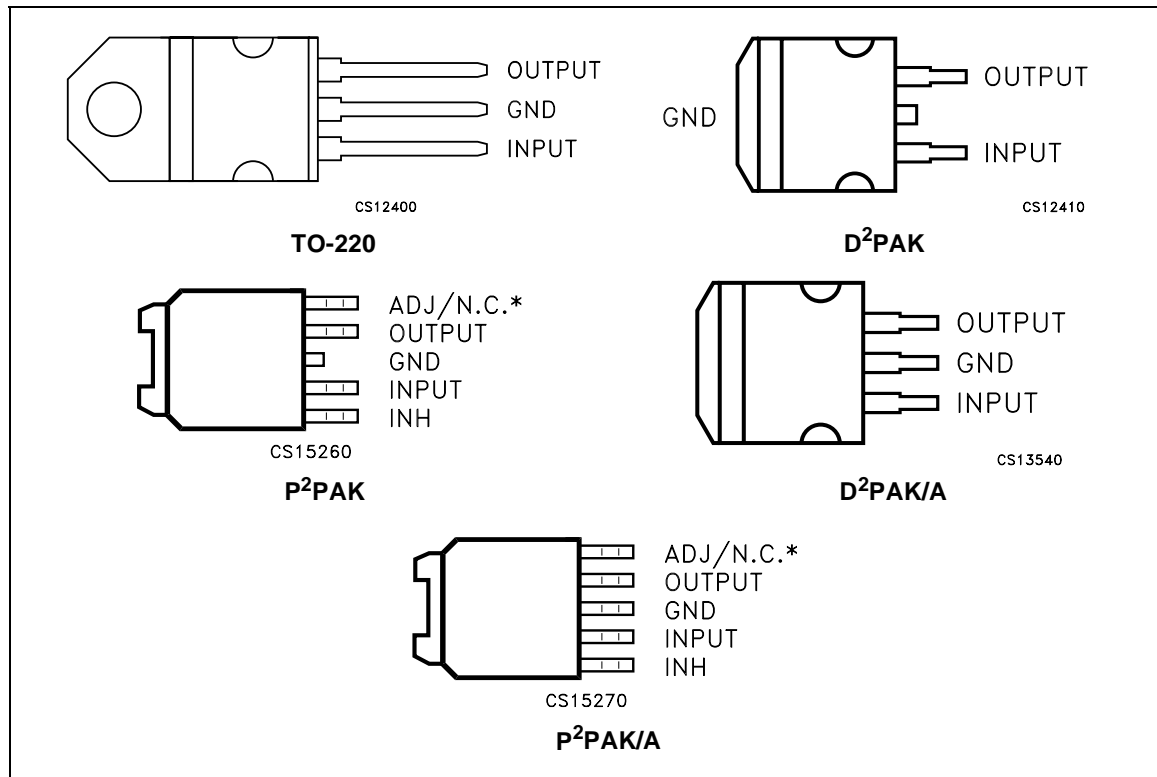

* Not connected for fixed version.

APPLICATION CIRCUIT

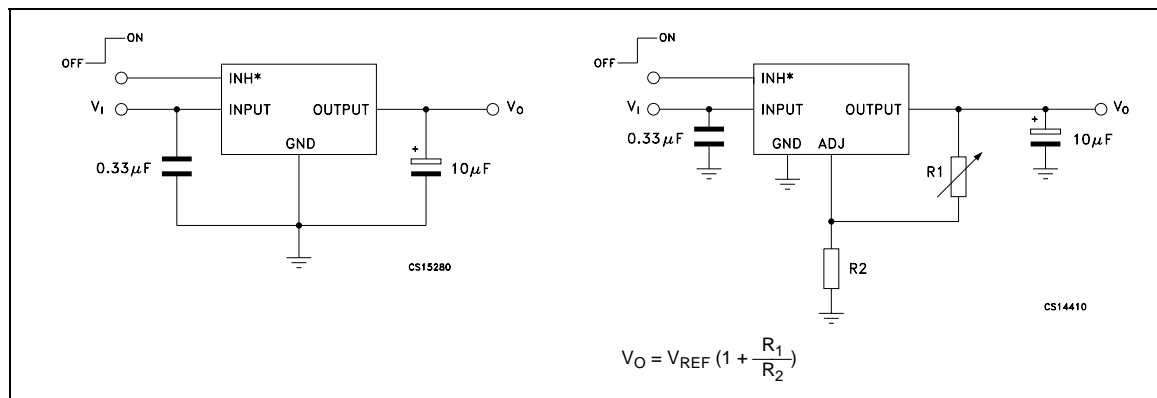

* Only for version with inhibit function.



LD29300 SERIES

ELECTRICAL CHARACTERISTICS OF LD29300#15

($I_O = 10\text{mA}$, $T_J = 25^\circ\text{C}$, $V_I = 3.5\text{V}$, $V_{INH} = 2\text{V}$ (Note 2), $C_I = 330\text{nF}$, $C_O = 10\mu\text{F}$, unless otherwise specified)

Symbol	Parameter	Test Conditions	Min.	Typ.	Max.	Unit
V_I	Minimum Operating Input Voltage	$I_O = 10\text{mA}$ to 3A $T_J = -40$ to 125°C	2.5			V
V_O	Output Voltage	$I_O = 10\text{mA}$ to 3A , $V_I = 3$ to 7V $T_J = -40$ to 125°C	1.485	1.5	1.515	V
ΔV_O	Load Regulation	$I_O = 10\text{mA}$ to 3A		0.2	1.0	%
ΔV_O	Line Regulation	$V_I = 3$ to 13V		0.06	0.5	%
SVR	Supply Voltage Rejection	$f = 120\text{Hz}$, $V_I = 3.5 \pm 1\text{V}$, $I_O = 1.5\text{A}$ (Note 1)	65	75		dB
I_q	Quiescent Current	$I_O = 1.5\text{A}$, $T_J = -40$ to 125°C		20	50	mA
		$I_O = 3\text{A}$, $T_J = -40$ to 125°C		45	100	
		$V_I = 13\text{V}$, $V_{INH} = \text{GND}$ $T_J = -40$ to 125°C		130	180	μA
I_{sc}	Short Circuit Current	$V_I - V_O = 5.5\text{V}$		4.5		A
V_{IL}	Control Input Logic Low	OFF MODE, (NOTE 2) $T_J = -40$ to 125°C			0.8	V
V_{IH}	Control Input Logic High	ON MODE, (NOTE 2) $T_J = -40$ to 125°C	2			V
I_{INH}	Control Input Current	$T_J = -40$ to 125°C $V_{INH} = 13\text{V}$		5	10	μA
eN	Output Noise Voltage	$B_p = 10\text{Hz}$ to 100KHz $I_O = 100\text{mA}$		60		μV_{RMS}

NOTE 1: Guaranteed by design.

NOTE 2: Only for version with Inhibit function.

ELECTRICAL CHARACTERISTICS OF LD29300#18

($I_O = 10\text{mA}$, $T_J = 25^\circ\text{C}$, $V_I = 3.8\text{V}$, $V_{INH} = 2\text{V}$ (Note 3), $C_I = 330\text{nF}$, $C_O = 10\mu\text{F}$, unless otherwise specified)

Symbol	Parameter	Test Conditions	Min.	Typ.	Max.	Unit
V_O	Output Voltage	$I_O = 10\text{mA}$ to 3A , $V_I = 3$ to 7.3V $T_J = -40$ to 125°C	1.782	1.8	1.818	V
			1.764		1.836	
ΔV_O	Load Regulation	$I_O = 10\text{mA}$ to 3A		0.2	1.0	%
ΔV_O	Line Regulation	$V_I = 3$ to 13V		0.06	0.5	%
SVR	Supply Voltage Rejection	$f = 120\text{Hz}$, $V_I = 3.8 \pm 1\text{V}$, $I_O = 1.5\text{A}$ (Note 1)	62	72		dB
V_{DROP}	Dropout Voltage	$I_O = 500\text{mA}$, $T_J = -40$ to 125°C (Note 2)		0.1		V
		$I_O = 1.5\text{A}$, $T_J = -40$ to 125°C (Note 2)		0.2		
		$I_O = 3\text{A}$, $T_J = -40$ to 125°C (Note 2)		0.4	0.7	
I_q	Quiescent Current	$I_O = 1.5\text{A}$, $T_J = -40$ to 125°C		20	50	mA
		$I_O = 3\text{A}$, $T_J = -40$ to 125°C		45	100	
		$V_I = 13\text{V}$, $V_{INH} = \text{GND}$ $T_J = -40$ to 125°C		130	180	μA
I_{sc}	Short Circuit Current	$V_I - V_O = 5.5\text{V}$		4.5		A
V_{IL}	Control Input Logic Low	OFF MODE, (NOTE 3) $T_J = -40$ to 125°C			0.8	V
V_{IH}	Control Input Logic High	ON MODE, (NOTE 3) $T_J = -40$ to 125°C	2			V
I_{INH}	Control Input Current	$T_J = -40$ to 125°C $V_{INH} = 13\text{V}$		5	10	μA
eN	Output Noise Voltage	$B_p = 10\text{Hz}$ to 100KHz $I_O = 100\text{mA}$		60		μV_{RMS}

NOTE 1: Guaranteed by design.

NOTE 2: Dropout voltage is defined as the input-to-output differential when the output voltage drops to 99% of its nominal value with $V_O + 1\text{V}$ applied to V_I .

NOTE 3: Only for version with Inhibit function.

ELECTRICAL CHARACTERISTICS OF LD29300#25(I_O = 10mA, T_J = 25°C, V_I = 4.5V, V_{INH} = 2V (Note 3), C_I = 330nF, C_O = 10μF, unless otherwise specified)

Symbol	Parameter	Test Conditions	Min.	Typ.	Max.	Unit
V _O	Output Voltage	I _O = 10mA to 3A, V _I = 3.5 to 8V T _J = -40 to 125°C	2.475	2.5	2.525	V
ΔV _O	Load Regulation	I _O = 10mA to 3A		0.2	1.0	%
ΔV _O	Line Regulation	V _I = 3.5 to 13V		0.06	0.5	%
SVR	Supply Voltage Rejection	f = 120 Hz, V _I = 4.5 ± 1V, I _O = 1.5A (Note 1)	55	70		dB
V _{DROP}	Dropout Voltage	I _O = 500mA, T _J = -40 to 125°C (Note 2)		0.1		V
		I _O = 1.5A, T _J = -40 to 125°C (Note 2)		0.2		
		I _O = 3A, T _J = -40 to 125°C (Note 2)		0.4	0.7	
I _q	Quiescent Current	I _O = 1.5A, T _J = -40 to 125°C		20	50	mA
		I _O = 3A, T _J = -40 to 125°C		45	100	
		V _I = 13V, V _{INH} = GND T _J = -40 to 125°C		130	180	μA
I _{sc}	Short Circuit Current	V _I - V _O = 5.5V		4.5		A
V _{IL}	Control Input Logic Low	OFF MODE, (NOTE 3) T _J = -40 to 125°C			0.8	V
V _{IH}	Control Input Logic High	ON MODE, (NOTE 3) T _J = -40 to 125°C	2			V
I _{INH}	Control Input Current	T _J = -40 to 125°C V _{INH} = 13V		5	10	μA
eN	Output Noise Voltage	B _p = 10Hz to 100KHz I _O = 100mA		100		μV _{RMS}

NOTE 1: Guaranteed by design.

NOTE 2: Dropout voltage is defined as the input-to-output differential when the output voltage drops to 99% of its nominal value with V_O+1V applied to V_I.

NOTE 3: Only for version with Inhibit function.

ELECTRICAL CHARACTERISTICS OF LD29300#33(I_O = 10mA, T_J = 25°C, V_I = 5.3V, V_{INH} = 2V (Note 3), C_I = 330nF, C_O = 10μF, unless otherwise specified)

Symbol	Parameter	Test Conditions	Min.	Typ.	Max.	Unit
V _O	Output Voltage	I _O = 10mA to 3A, V _I = 4.3 to 8.8V T _J = -40 to 125°C	3.267	3.3	3.333	V
			3.234		3.366	
ΔV _O	Load Regulation	I _O = 10mA to 3A		0.2	1.0	%
ΔV _O	Line Regulation	V _I = 4.3 to 13V		0.06	0.5	%
SVR	Supply Voltage Rejection	f = 120 Hz, V _I = 5.3 ± 1V, I _O = 1.5A (Note 1)	52	67		dB
V _{DROP}	Dropout Voltage	I _O = 500mA, T _J = -40 to 125°C (Note 2)		0.1		V
		I _O = 1.5A, T _J = -40 to 125°C (Note 2)		0.2		
		I _O = 3A, T _J = -40 to 125°C (Note 2)		0.4	0.7	
I _q	Quiescent Current	I _O = 1.5A, T _J = -40 to 125°C		20	50	mA
		I _O = 3A, T _J = -40 to 125°C		45	100	
		V _I = 13V, V _{INH} = GND T _J = -40 to 125°C		130	180	μA
I _{sc}	Short Circuit Current	V _I - V _O = 5.5V		4.5		A
V _{IL}	Control Input Logic Low	OFF MODE, (NOTE 3) T _J = -40 to 125°C			0.8	V
V _{IH}	Control Input Logic High	ON MODE, (NOTE 3) T _J = -40 to 125°C	2			V
I _{INH}	Control Input Current	T _J = -40 to 125°C V _{INH} = 13V		5	10	μA
eN	Output Noise Voltage	B _p = 10Hz to 100KHz I _O = 100mA		132		μV _{RMS}

NOTE 1: Guaranteed by design.

NOTE 2: Dropout voltage is defined as the input-to-output differential when the output voltage drops to 99% of its nominal value with V_O+1V applied to V_I.

NOTE 3: Only for version with Inhibit function.



LD29300 SERIES

ELECTRICAL CHARACTERISTICS OF LD29300#50

($I_O = 10\text{mA}$, $T_J = 25^\circ\text{C}$, $V_I = 7\text{V}$, $V_{INH} = 2\text{V}$ (Note 3), $C_I = 330\text{nF}$, $C_O = 10\mu\text{F}$, unless otherwise specified)

Symbol	Parameter	Test Conditions	Min.	Typ.	Max.	Unit
V_O	Output Voltage	$I_O = 10\text{mA to } 3\text{A}$, $V_I = 6 \text{ to } 10.5\text{V}$ $T_J = -40 \text{ to } 125^\circ\text{C}$	4.95	5	5.05	V
			4.9		5.1	
ΔV_O	Load Regulation	$I_O = 10\text{mA to } 3\text{A}$		0.2	1.0	%
ΔV_O	Line Regulation	$V_I = 6 \text{ to } 13\text{V}$		0.06	0.5	%
SVR	Supply Voltage Rejection	$f = 120 \text{ Hz}$, $V_I = 7 \pm 1\text{V}$, $I_O = 1.5\text{A}$ (Note 1)	49	64		dB
V_{DROP}	Dropout Voltage	$I_O = 500\text{mA}$, $T_J = -40 \text{ to } 125^\circ\text{C}$ (Note 2)		0.1		V
		$I_O = 1.5\text{A}$, $T_J = -40 \text{ to } 125^\circ\text{C}$ (Note 2)		0.2		
		$I_O = 3\text{A}$, $T_J = -40 \text{ to } 125^\circ\text{C}$ (Note 2)		0.4	0.7	
I_q	Quiescent Current	$I_O = 1.5\text{A}$, $T_J = -40 \text{ to } 125^\circ\text{C}$		20	50	mA
		$I_O = 3\text{A}$, $T_J = -40 \text{ to } 125^\circ\text{C}$		45	100	
		$V_I = 13\text{V}$, $V_{INH} = \text{GND}$ $T_J = -40 \text{ to } 125^\circ\text{C}$		130	180	μA
I_{sc}	Short Circuit Current	$V_I - V_O = 5.5\text{V}$		4.5		A
V_{IL}	Control Input Logic Low	OFF MODE, (NOTE 3) $T_J = -40 \text{ to } 125^\circ\text{C}$			0.8	V
V_{IH}	Control Input Logic High	ON MODE, (NOTE 3) $T_J = -40 \text{ to } 125^\circ\text{C}$	2			V
I_{INH}	Control Input Current	$T_J = -40 \text{ to } 125^\circ\text{C}$ $V_{INH} = 13\text{V}$		5	10	μA
eN	Output Noise Voltage	$B_p = 10\text{Hz to } 100\text{KHz}$ $I_O = 100\text{mA}$		200		μV_{RMS}

NOTE 1: Guaranteed by design.

NOTE 2: Dropout voltage is defined as the input-to-output differential when the output voltage drops to 99% of its nominal value with $V_O + 1\text{V}$ applied to V_I .

NOTE 3: Only for version with Inhibit function.

ELECTRICAL CHARACTERISTICS OF LD29300#80

($I_O = 10\text{mA}$, $T_J = 25^\circ\text{C}$, $V_I = 10\text{V}$, $V_{INH} = 2\text{V}$ (Note 3), $C_I = 330\text{nF}$, $C_O = 10\mu\text{F}$, unless otherwise specified)

Symbol	Parameter	Test Conditions	Min.	Typ.	Max.	Unit
V_O	Output Voltage	$I_O = 10\text{mA to } 3\text{A}$, $V_I = 9 \text{ to } 13\text{V}$ $T_J = -40 \text{ to } 125^\circ\text{C}$	7.92	8	8.08	V
			7.84		8.16	
ΔV_O	Load Regulation	$I_O = 10\text{mA to } 3\text{A}$		0.2	1.0	%
ΔV_O	Line Regulation	$V_I = 9 \text{ to } 13\text{V}$		0.06	0.5	%
SVR	Supply Voltage Rejection	$f = 120 \text{ Hz}$, $V_I = 9 \pm 1\text{V}$, $I_O = 1.5\text{A}$ (Note 1)	45	59		dB
V_{DROP}	Dropout Voltage	$I_O = 500\text{mA}$, $T_J = -40 \text{ to } 125^\circ\text{C}$ (Note 2)		0.1		V
		$I_O = 1.5\text{A}$, $T_J = -40 \text{ to } 125^\circ\text{C}$ (Note 2)		0.2		
		$I_O = 3\text{A}$, $T_J = -40 \text{ to } 125^\circ\text{C}$ (Note 2)		0.4	0.7	
I_q	Quiescent Current	$I_O = 1.5\text{A}$, $T_J = -40 \text{ to } 125^\circ\text{C}$		20	50	mA
		$I_O = 3\text{A}$, $T_J = -40 \text{ to } 125^\circ\text{C}$		45	100	
		$V_I = 13\text{V}$, $V_{INH} = \text{GND}$ $T_J = -40 \text{ to } 125^\circ\text{C}$		130	180	μA
I_{sc}	Short Circuit Current	$V_I - V_O = 5.5\text{V}$		4.5		A
V_{IL}	Control Input Logic Low	OFF MODE, (NOTE 3) $T_J = -40 \text{ to } 125^\circ\text{C}$			0.8	V
V_{IH}	Control Input Logic High	ON MODE, (NOTE 3) $T_J = -40 \text{ to } 125^\circ\text{C}$	2			V
I_{INH}	Control Input Current	$T_J = -40 \text{ to } 125^\circ\text{C}$ $V_{INH} = 13\text{V}$		5	10	μA
eN	Output Noise Voltage	$B_p = 10\text{Hz to } 100\text{KHz}$ $I_O = 100\text{mA}$		320		μV_{RMS}

NOTE 1: Guaranteed by design.

NOTE 2: Dropout voltage is defined as the input-to-output differential when the output voltage drops to 99% of its nominal value with $V_O + 1\text{V}$ applied to V_I .

NOTE 3: Only for version with Inhibit function.

ELECTRICAL CHARACTERISTICS OF LD29300#90(I_O = 10mA, T_J = 25° C, V_I = 11V, V_{INH} = 2V (Note 3), C_I = 330nF, C_O = 10μF, unless otherwise specified)

Symbol	Parameter	Test Conditions	Min.	Typ.	Max.	Unit
V _O	Output Voltage	I _O = 10mA to 3A, V _I = 10 to 13V T _J = -40 to 125° C	8.91	9	9.09	V
ΔV _O	Load Regulation	I _O = 10mA to 3A		0.2	1.0	%
ΔV _O	Line Regulation	V _I = 10 to 13V		0.06	0.5	%
SVR	Supply Voltage Rejection	f = 120 Hz, V _I = 11 ± 1V, I _O = 1.5A (Note 1)	45	58		dB
V _{DROP}	Dropout Voltage	I _O = 500mA, T _J = -40 to 125° C (Note 2)		0.1		V
		I _O = 1.5A, T _J = -40 to 125° C (Note 2)		0.2		
		I _O = 3A, T _J = -40 to 125° C (Note 2)		0.4	0.7	
I _q	Quiescent Current	I _O = 1.5A, T _J = -40 to 125° C		20	50	mA
		I _O = 3A, T _J = -40 to 125° C		50	100	
		V _I = 13V, V _{INH} = GND T _J = -40 to 125° C		130	180	μA
I _{sc}	Short Circuit Current	V _I - V _O = 5.5V		4.5		A
V _{IL}	Control Input Logic Low	OFF MODE, (NOTE 3) T _J = -40 to 125° C			0.8	V
V _{IH}	Control Input Logic High	ON MODE, (NOTE 3) T _J = -40 to 125° C	2			V
I _{INH}	Control Input Current	T _J = -40 to 125° C V _{INH} = 13V		5	10	μA
eN	Output Noise Voltage	B _p = 10Hz to 100KHz I _O = 100mA		360		μV _{RMS}

NOTE 1: Guaranteed by design.

NOTE 2: Dropout voltage is defined as the input-to-output differential when the output voltage drops to 99% of its nominal value with V_O+1V applied to V_I.

NOTE 3: Only for version with Inhibit function.

ELECTRICAL CHARACTERISTICS OF LD29300#ADJ(I_O = 10mA, T_J = 25° C, V_I = 3.23 V, V_{INH} = 2V (Note 3), C_I = 330nF, C_O = 10μF adjust pin tied to output)

Symbol	Parameter	Test Conditions	Min.	Typ.	Max.	Unit
V _I	Minimum Operating Input Voltage	I _O = 10mA to 3A T _J = -40 to 125° C	2.5			V
ΔV _O	Load Regulation	I _O = 10mA to 3A		0.2	1.0	%
ΔV _O	Line Regulation	V _I = 2.5 V to 13V		0.06	0.5	%
V _{REF}	Reference Voltage	I _O = 10mA to 3A, V _I = 2.5 to 4.5V T _J = -40 to 125° C (Note 2)	-1%	1.23	+1%	V
SVR	Supply Voltage Rejection	f = 120 Hz, V _I = 3.23 ± 1V, I _O = 1.5A (Note 1)	65	75		dB
I _q	Quiescent Current	I _O = 1.5A, T _J = -40 to 125° C		20	50	mA
		I _O = 3A, T _J = -40 to 125° C		45	100	
		V _I = 13V, V _{INH} = GND T _J = -40 to 125° C		130	180	μA
I _{ADJ}	Adjust Pin Current	T _J = -40 to 125° C (Note 1)			1	μA
I _{sc}	Short Circuit Current	V _I - V _O = 5.5V		4.5		A
V _{IL}	Control Input Logic Low	OFF MODE, (NOTE 3) T _J = -40 to 125° C			0.8	V
V _{IH}	Control Input Logic High	ON MODE, (NOTE 3) T _J = -40 to 125° C	2			V
I _{INH}	Control Input Current	T _J = -40 to 125° C V _{INH} = 13V		5	10	μA
eN	Output Noise Voltage	B _p = 10Hz to 100KHz I _O = 100mA		50		μV _{RMS}

NOTE 1: Guaranteed by design.

NOTE 2: Reference Voltage is measured between output and GND pin, with ADJ PIN tied to V_{OUT}.

NOTE 3: Only for version with Inhibit function.



LD29300 SERIES

TYPICAL CHARACTERISTICS ($C_I = 330\text{nF}$, $C_O = 10\mu\text{F}$)

Figure 1 : Output Voltage vs Temperature

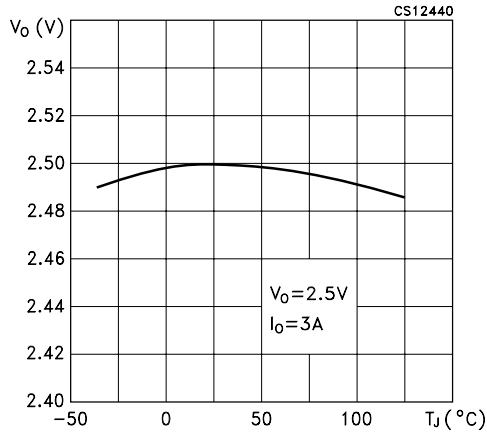

Figure 2 : Dropout Voltage vs Temperature

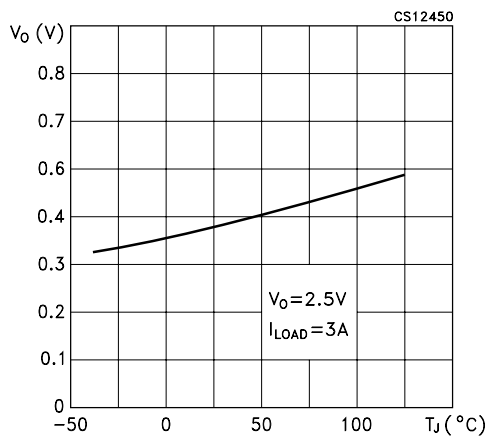

Figure 3 : Dropout Voltage vs Output Current

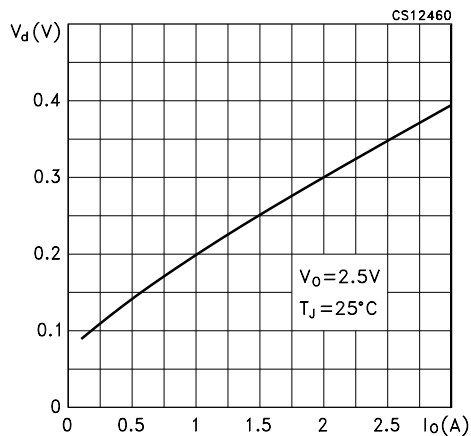

Figure 4 : Quiescent Current vs Output Current

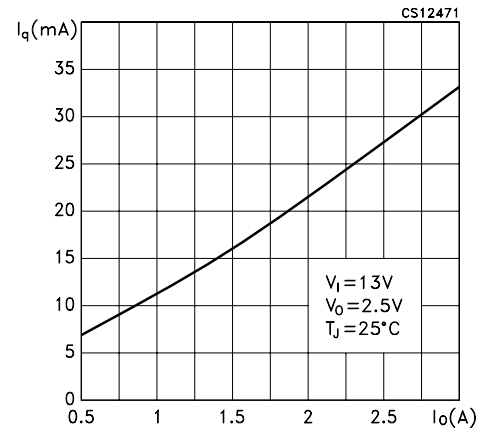

Figure 5 : Quiescent Current vs Output Current

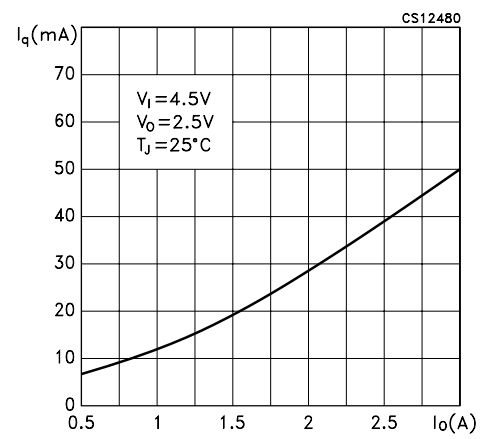

Figure 6 : Quiescent Current vs Supply Voltage

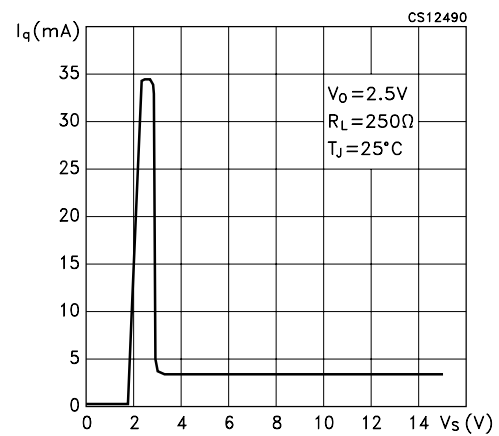

Figure 7 : Quiescent Current vs Temperature

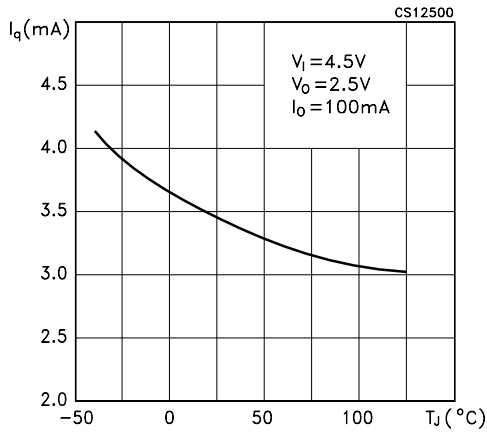

Figure 10 : Supply Voltage Rejection vs Temperature

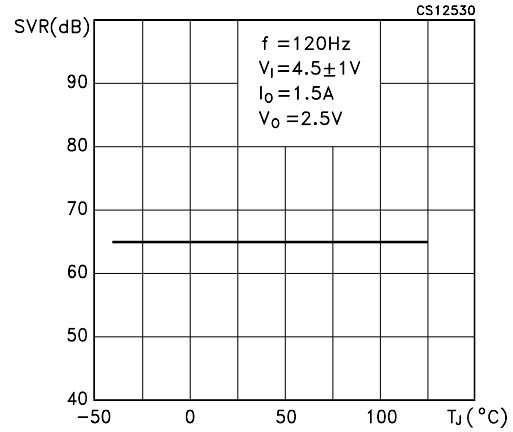

Figure 8 : Quiescent Current vs Temperature

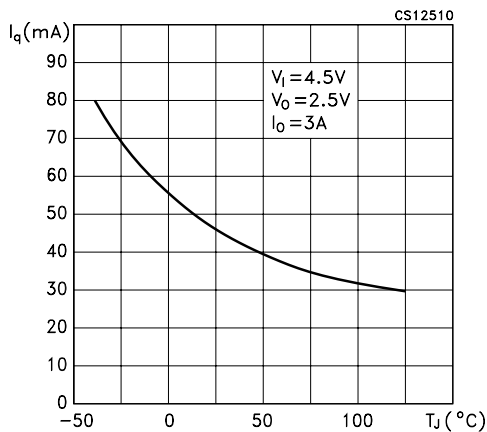

Figure 11 : Stability vs Co

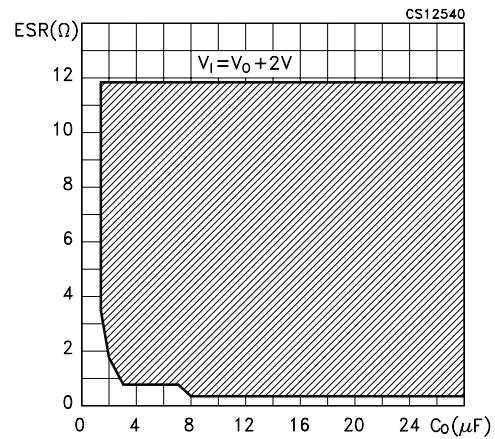

Figure 9 : Short Circuit Current vs Temperature

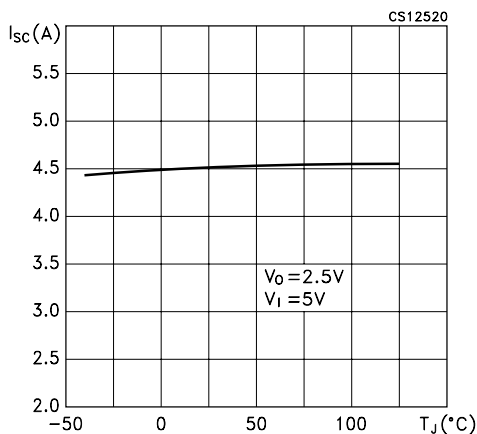
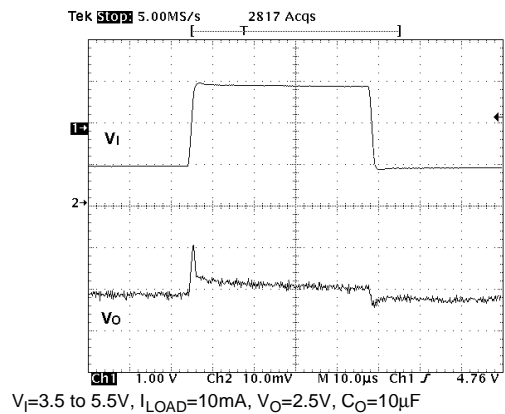
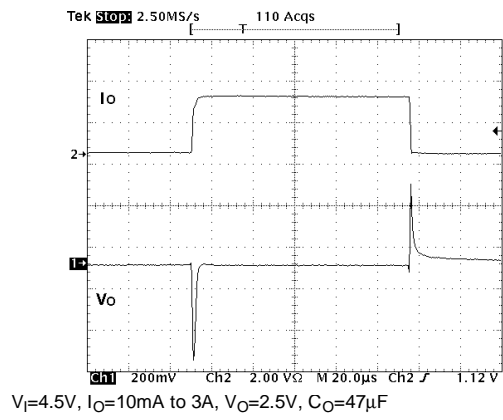

Figure 12 : Line Transient



LD29300 SERIES

Figure 13 : Load Transient



TO-220 MECHANICAL DATA

DIM.	mm.			inch		
	MIN.	TYP	MAX.	MIN.	TYP.	MAX.
A	4.40		4.60	0.173		0.181
C	1.23		1.32	0.048		0.051
D	2.40		2.72	0.094		0.107
D1		1.27			0.050	
E	0.49		0.70	0.019		0.027
F	0.61		0.88	0.024		0.034
F1	1.14		1.70	0.044		0.067
F2	1.14		1.70	0.044		0.067
G	4.95		5.15	0.194		0.203
G1	2.4		2.7	0.094		0.106
H2	10.0		10.40	0.393		0.409
L2		16.4			0.645	
L4	13.0		14.0	0.511		0.551
L5	2.65		2.95	0.104		0.116
L6	15.25		15.75	0.600		0.620
L7	6.2		6.6	0.244		0.260
L9	3.5		3.93	0.137		0.154
DIA.	3.75		3.85	0.147		0.151

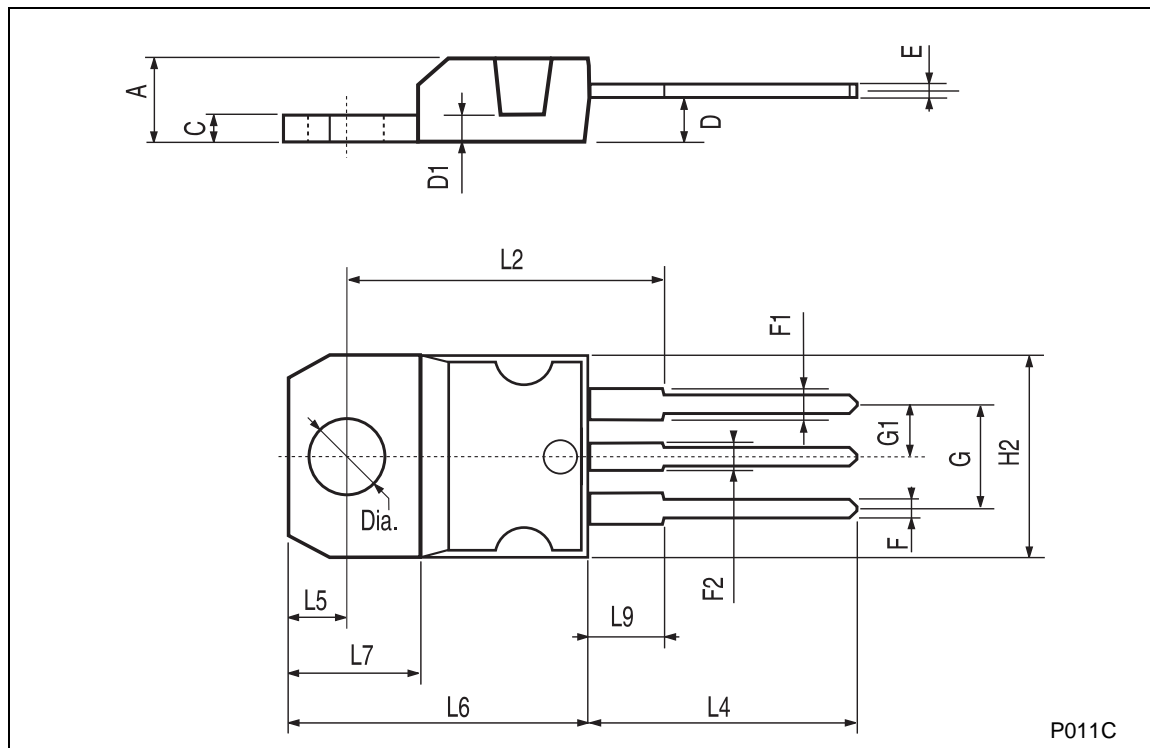

LD29300 SERIES

D²PAK MECHANICAL DATA

DIM.	mm.			inch		
	MIN.	TYP	MAX.	MIN.	TYP.	MAX.
A	4.4		4.6	0.173		0.181
A1	2.49		2.69	0.098		0.106
A2	0.03		0.23	0.001		0.009
B	0.7		0.93	0.027		0.036
B2	1.14		1.7	0.044		0.067
C	0.45		0.6	0.017		0.023
C2	1.23		1.36	0.048		0.053
D	8.95		9.35	0.352		0.368
D1		8			0.315	
E	10		10.4	0.393		0.409
E1		8.5			0.335	
G	4.88		5.28	0.192		0.208
L	15		15.85	0.590		0.624
L2	1.27		1.4	0.050		0.055
L3	1.4		1.75	0.055		0.068
M	2.4		3.2	0.094		0.126
R		0.4			0.016	
V2	0°		8°	0°		8°

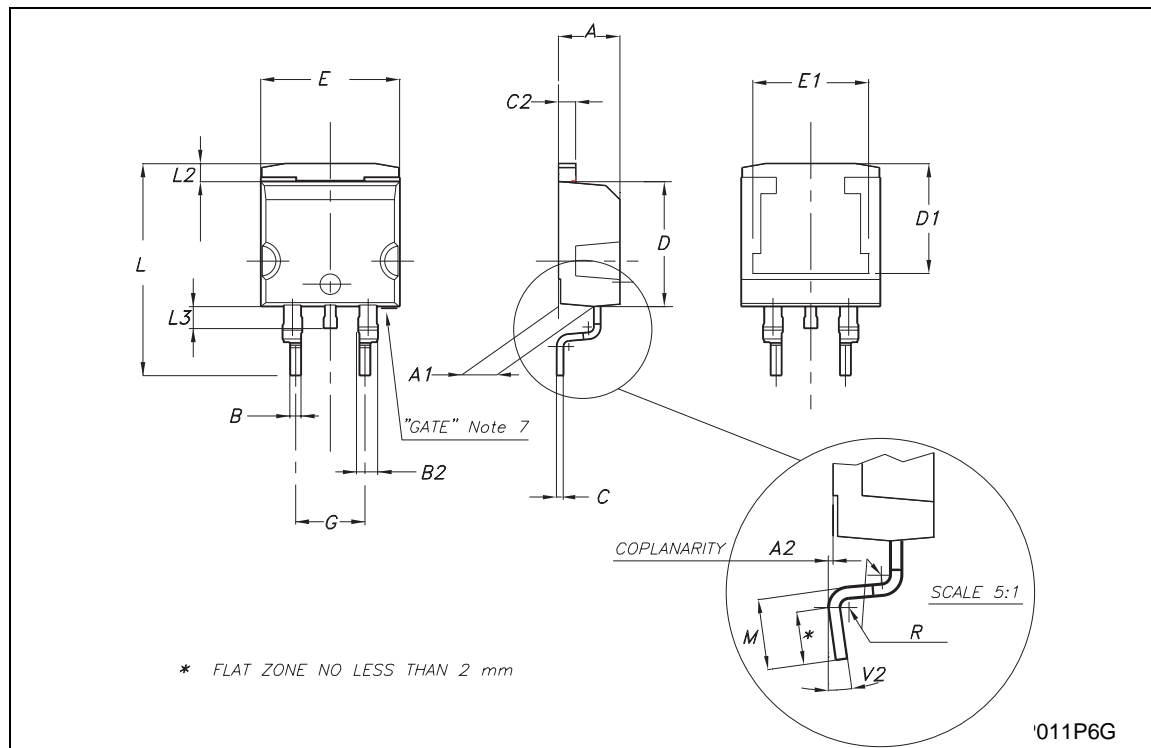

P²PAK MECHANICAL DATA

DIM.	mm.			inch		
	MIN.	TYP	MAX.	MIN.	TYP.	MAX.
A	4.30		4.80	0.169		0.188
A1	2.40		2.80	0.094		0.110
A2	0.03		0.23	0.001		0.009
b	0.80		1.05	0.031		0.041
c	0.45		0.60	0.017		0.023
c2	1.17		1.37	0.046		0.053
D	8.95		9.35	0.352		0.368
D2		8			0.315	
E	10.00		10.40	0.393		0.409
E1		8.5			0.334	0.409
e	3.20		3.60	0.126		0.142
e1	6.60		7.00	0.260		0.275
L	13.70		14.50	0.539		0.571
L2	1.25		1.40	0.049		0.055
L3	0.90		1.70	0.035		0.067
L5	1.55		2.40	0.061		0.094
R		0.40			0.016	
V2	0°		8°	0°		8°

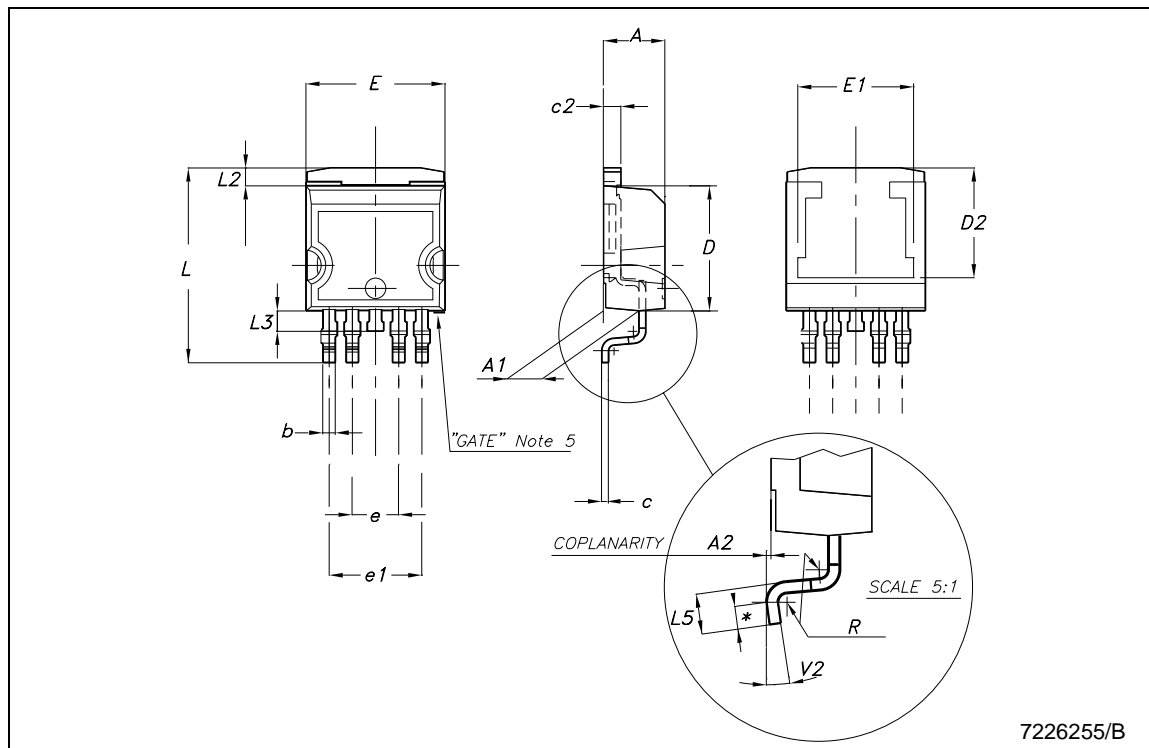

D²PAK/A MECHANICAL DATA

DIM.	mm.			inch		
	MIN.	TYP.	MAX.	MIN.	TYP.	MAX.
A	4.40		4.60	0.173		0.181
A1	2.49		2.69	0.098		0.106
B	0.7		0.93	0.027		0.036
B2	1.14		1.7	0.044		0.067
C	0.45		0.60	0.017		0.023
C2	1.21		1.36	0.047		0.053
D	8.95		9.35	0.352		0.368
E	10		10.4	0.393		0.409
G	4.88		5.28	0.192		0.208
L	15		15.85	0.590		0.106
L2	1.27		1.4	0.050		0.055

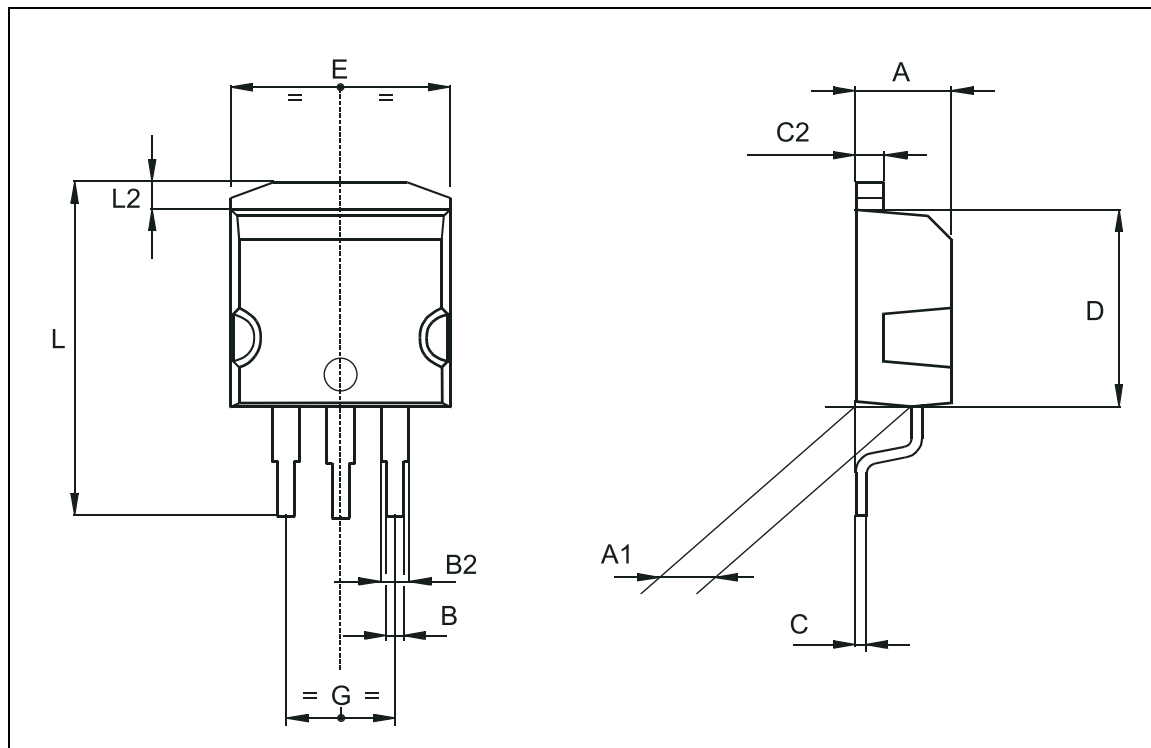

P²PAK/A MECHANICAL DATA

DIM.	mm.			inch		
	MIN.	TYP	MAX.	MIN.	TYP.	MAX.
A	4.30		4.80	0.169		0.188
A2	0.03		0.23	0.001		0.009
C	1.17		1.37	0.046		0.053
D	2.40		2.80	0.094		0.110
D1	8.95		9.35	0.352		0.368
E	0.45		0.60	0.017		0.023
F	0.80		1.05	0.031		0.041
G	3.20		3.60	0.126		0.142
G1	6.60		7.00	0.260		0.275
H1		8.5			0.334	0.409
H2	10.00		10.40	0.393		0.409
L	15		15.85	0.590		0.624
L1		8			0.315	
L2	1.27		1.40	0.050		0.055
M	2.4		3.2	0.094		0.126
R		0.40	3.2		0.016	
V2	0°		8°	0°		8°

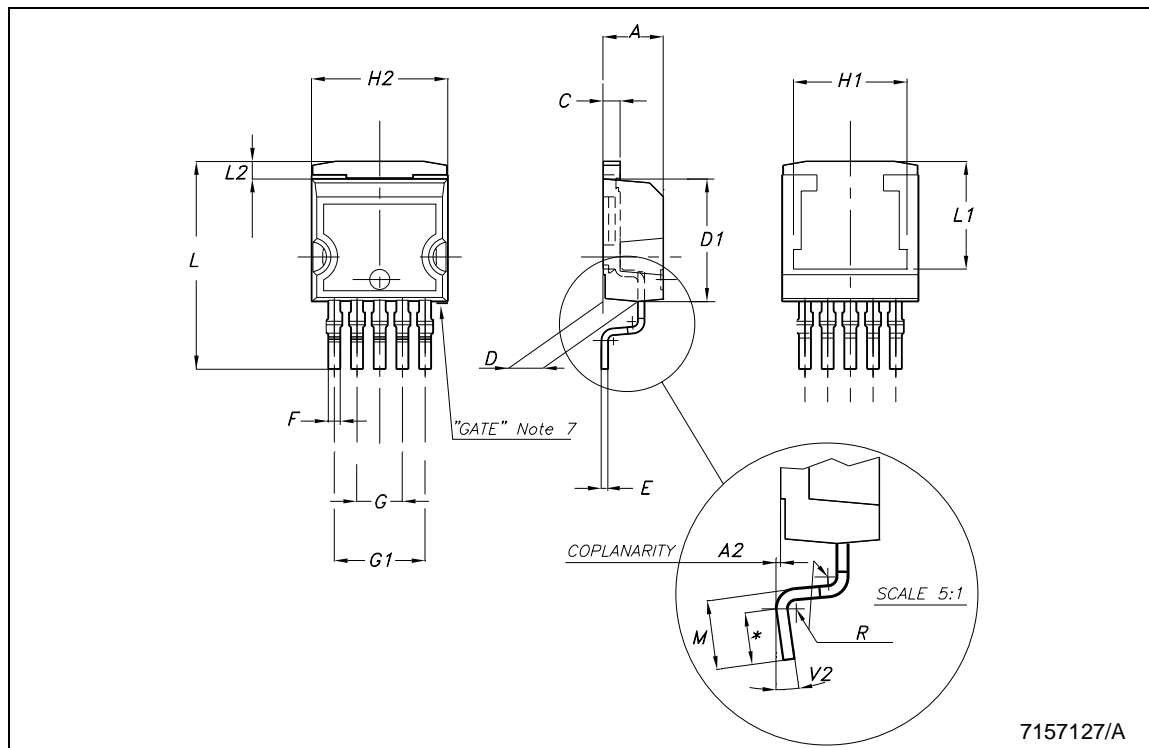

Tape & Reel D²PAK-P²PAK-D²PAK/A-P²PAK/A MECHANICAL DATA

DIM.	mm.			inch		
	MIN.	TYP	MAX.	MIN.	TYP.	MAX.
A			180			7.086
C	12.8	13.0	13.2	0.504	0.512	0.519
D	20.2			0.795		
N	60			2.362		
T			14.4			0.567
Ao	10.50	10.6	10.70	0.413	0.417	0.421
Bo	15.70	15.80	15.90	0.618	0.622	0.626
Ko	4.80	4.90	5.00	0.189	0.193	0.197
Po	3.9	4.0	4.1	0.153	0.157	0.161
P	11.9	12.0	12.1	0.468	0.472	0.476

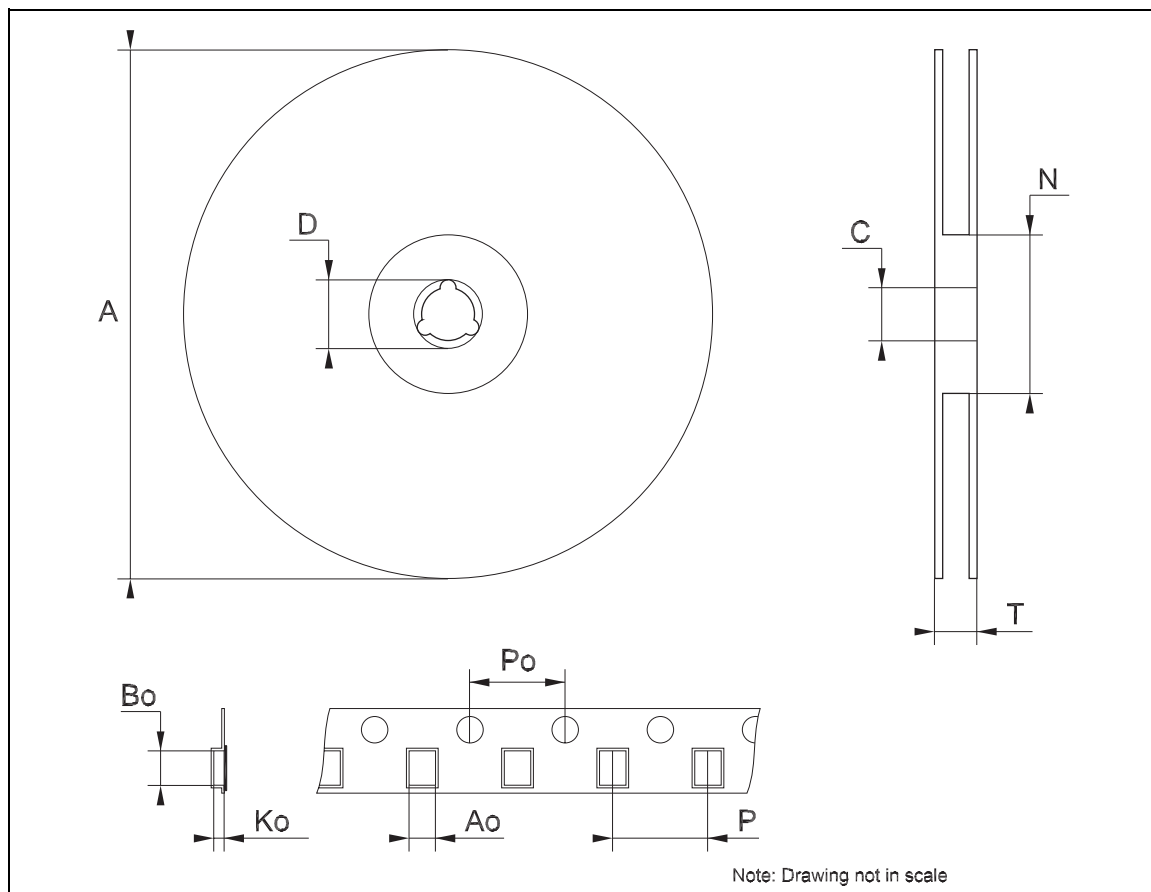

Information furnished is believed to be accurate and reliable. However, STMicroelectronics assumes no responsibility for the consequences of use of such information nor for any infringement of patents or other rights of third parties which may result from its use. No license is granted by implication or otherwise under any patent or patent rights of STMicroelectronics. Specifications mentioned in this publication are subject to change without notice. This publication supersedes and replaces all information previously supplied. STMicroelectronics products are not authorized for use as critical components in life support devices or systems without express written approval of STMicroelectronics.

© The ST logo is a registered trademark of STMicroelectronics

© 2003 STMicroelectronics - Printed in Italy - All Rights Reserved
STMicroelectronics GROUP OF COMPANIES

Australia - Brazil - Canada - China - Finland - France - Germany - Hong Kong - India - Israel - Italy - Japan - Malaysia - Malta - Morocco
Singapore - Spain - Sweden - Switzerland - United Kingdom - United States.

© <http://www.st.com>

