

---



---

## SUPER-SMALL PACKAGE CMOS VOLTAGE REGULATOR S-817 Series

---



---

The S-817 Series is a 3-terminal positive voltage regulator, developed using CMOS technology. Small ceramic capacitors can be used as the output capacitor, and the S-817 series provides stable operation with low loads down to 1  $\mu$ A.

Compared with the conventional voltage regulator, it is of low current consumption, and with a lineup of the super small package (SNT-4A:1.2 x 1.6mm). It is optimal as a power supply of small portable device.

### ■ Features

- Ultra-low current consumption: Operating current: Typ. 1.2  $\mu$ A, Max. 2.5  $\mu$ A
- Output voltage: 1.1 to 6.0 V, selectable in 0.1 V steps.
- Output voltage accuracy:  $\pm 2.0\%$
- Output current: 50 mA capable (3.0 V output product,  $V_{IN}=5$  V) \*1  
75 mA capable (5.0 V output product,  $V_{IN}=7$  V) \*1
- Dropout voltage: Typ. 160 mV ( $V_{OUT} = 5.0$  V,  $I_{OUT} = 10$  mA)
- Low ESR capacitor (e.g. A ceramic capacitor of 0.1  $\mu$ F or more) can be used as an output capacitor.
- Short circuit protection for: Series A
- Excellent Line Regulation: Stable operation at light load of 1  $\mu$ A

\*1. Attention should be paid to the power dissipation of the package when the load is large.

### ■ Applications

- Power source for battery-powered devices
- Power source for personal communication devices
- Power source for home electric/electronic appliances

### ■ Packages

Package name	Drawing code			
	Package	Tape	Reel	Zigzag
SNT-4A	PF004-A	PF004-A	PF004-A	—
SC-82AB	NP004-A	NP004-A	NP004-A	—
SOT-23-5	MP005-A	MP005-A	MP005-A	—
SOT-89-3	UP003-A	UP003-A	UP003-A	—
TO-92 (Bulk)	YS003-B	—	—	—
TO-92 (Tape and reel)	YF003-A	YF003-A	YF003-A	—
TO-92 (Tape and ammo)	YF003-A	YZ003-C	—	YZ003-C

■ **Block Diagrams**

**1. S-817A Series**

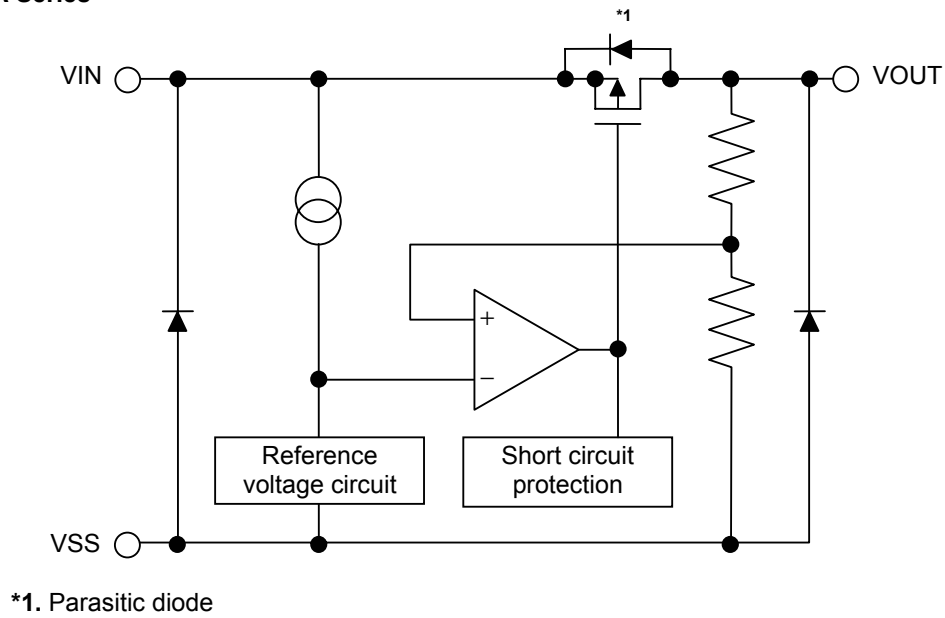

**Figure 1**

**2. S-817B Series**

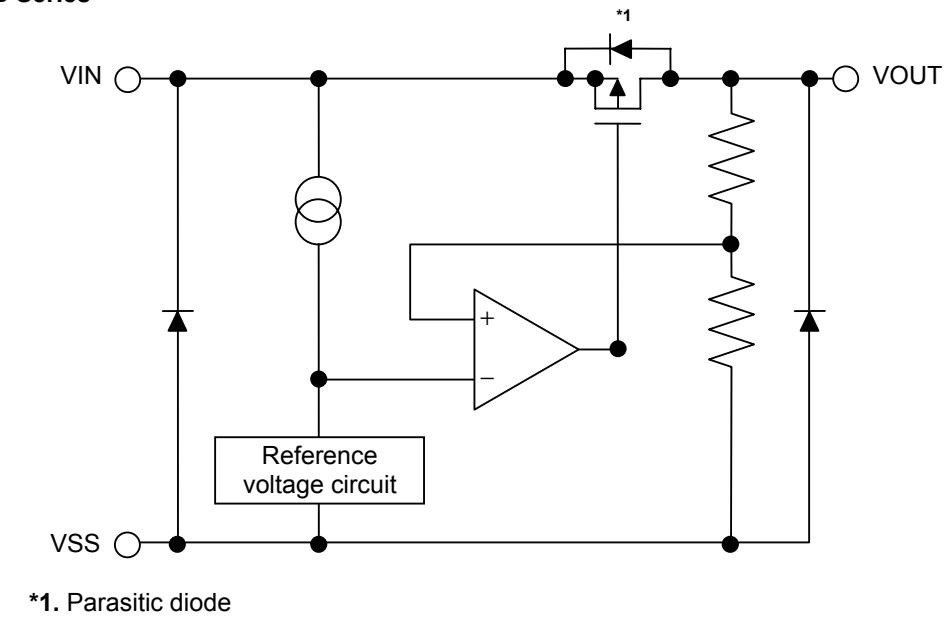

**Figure 2**

■ Product Name Structure

- The product types and output voltage for the S-817 Series can be selected at the user's request. Refer to the "Product name" for the meanings of the characters in the product name and "Product name list" for the full product names

1. Product name

1.1 S-817A series

1.1.1 SNT-4A package

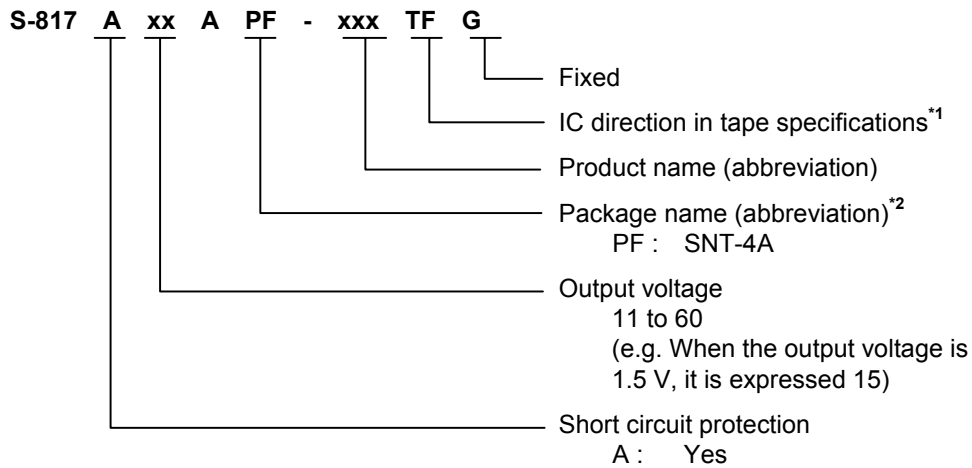

\*1. Refer to the specifications at the end of this book.

\*2. Refer to the "2. Product name list".

1.1.2 SC-82AB and SOT-23-5 package

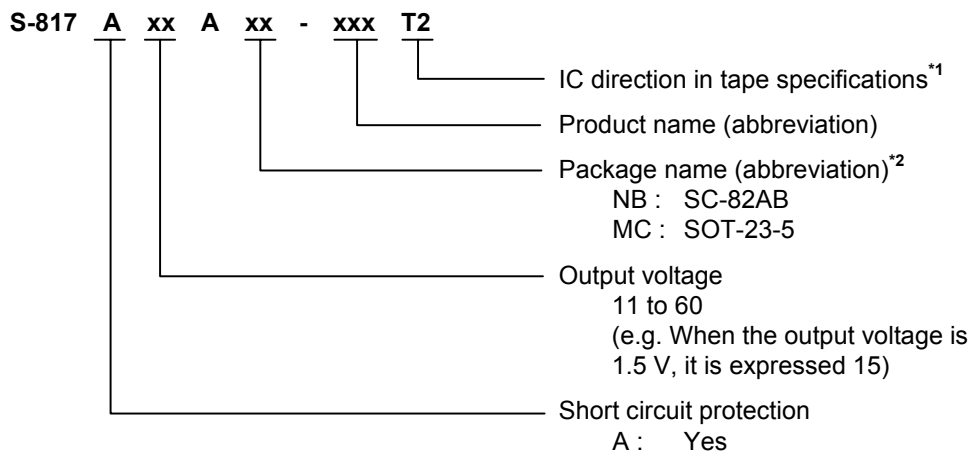

\*1. Refer to the specifications at the end of this book.

\*2. Refer to the "2. Product name list".

**1. 2 S-817B series**

**1. 2. 1 SOT-23-5 and SOT-89-3 package**

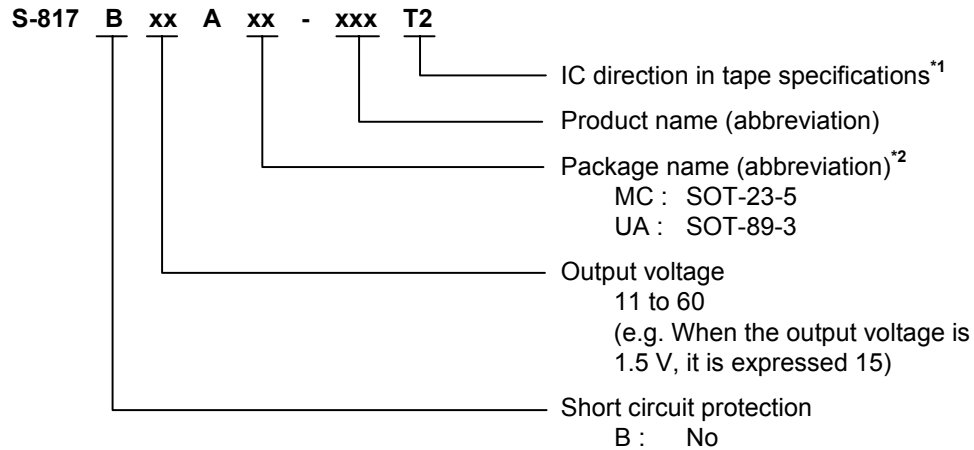

\*1. Refer to the specifications at the end of this book.

\*2. Refer to the "2. Product name list".

**1. 2. 2 TO-92 package**

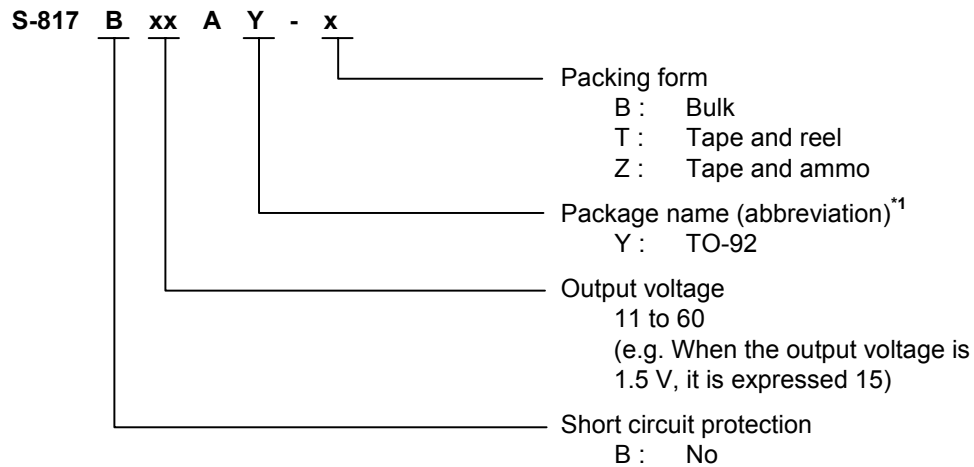

\*1. Refer to the "2. Product name list".

**2. Product name list**

**2.1 S-817A series**

**Table 1**

Output voltage	SNT-4A	SC-82AB	SOT-23-5
1.1 V ± 2.0 %	S-817A11APF-CUATFG	S-817A11ANB-CUA-T2	—
1.2 V ± 2.0 %	S-817A12APF-CUBTFG	S-817A12ANB-CUB-T2	—
1.3 V ± 2.0 %	S-817A13APF-CUCTFG	S-817A13ANB-CUC-T2	—
1.4 V ± 2.0 %	S-817A14APF-CUDTFG	S-817A14ANB-CUD-T2	S-817A14AMC-T2
1.5 V ± 2.0 %	S-817A15APF-CUETFG	S-817A15ANB-CUE-T2	—
1.6 V ± 2.0 %	S-817A16APF-CUFTFG	S-817A16ANB-CUF-T2	S-817A16AMC-T2
1.7 V ± 2.0 %	S-817A17APF-CUGTFG	S-817A17ANB-CUG-T2	—
1.8 V ± 2.0 %	S-817A18APF-CUHTFG	S-817A18ANB-CUH-T2	—
1.9 V ± 2.0 %	S-817A19APF-CUITFG	S-817A19ANB-CUI-T2	—
2.0 V ± 2.0 %	S-817A20APF-CUJTFG	S-817A20ANB-CUJ-T2	—
2.1 V ± 2.0 %	S-817A21APF-CUKTFG	S-817A21ANB-CUK-T2	—
2.2 V ± 2.0 %	S-817A22APF-CULTFG	S-817A22ANB-CUL-T2	—
2.3 V ± 2.0 %	S-817A23APF-CUMTFG	S-817A23ANB-CUM-T2	—
2.4 V ± 2.0 %	S-817A24APF-CUNTFG	S-817A24ANB-CUN-T2	—
2.5 V ± 2.0 %	S-817A25APF-CUOTFG	S-817A25ANB-CUO-T2	—
2.6 V ± 2.0 %	S-817A26APF-CUPTFG	S-817A26ANB-CUP-T2	—
2.7 V ± 2.0 %	S-817A27APF-CUQTFG	S-817A27ANB-CUQ-T2	—
2.8 V ± 2.0 %	S-817A28APF-CURTFG	S-817A28ANB-CUR-T2	—
2.9 V ± 2.0 %	S-817A29APF-CUSTFG	S-817A29ANB-CUS-T2	—
3.0 V ± 2.0 %	S-817A30APF-CUTTFG	S-817A30ANB-CUT-T2	—
3.1 V ± 2.0 %	S-817A31APF-CUUTFG	S-817A31ANB-CUU-T2	—
3.2 V ± 2.0 %	S-817A32APF-CUVTFG	S-817A32ANB-CUV-T2	—
3.3 V ± 2.0 %	S-817A33APF-CUWTFG	S-817A33ANB-CUW-T2	—
3.4 V ± 2.0 %	S-817A34APF-CUXTFG	S-817A34ANB-CUX-T2	—
3.5 V ± 2.0 %	S-817A35APF-CUYTFG	S-817A35ANB-CUY-T2	—
3.6 V ± 2.0 %	S-817A36APF-CUZTFG	S-817A36ANB-CUZ-T2	—
3.7 V ± 2.0 %	S-817A37APF-CVATFG	S-817A37ANB-CVA-T2	—
3.8 V ± 2.0 %	S-817A38APF-CVBTFG	S-817A38ANB-CVB-T2	—
3.9 V ± 2.0 %	S-817A39APF-CVCTFG	S-817A39ANB-CVC-T2	—
4.0 V ± 2.0 %	S-817A40APF-CVDTFG	S-817A40ANB-CVD-T2	—
4.1 V ± 2.0 %	S-817A41APF-CVETFG	S-817A41ANB-CVE-T2	—
4.2 V ± 2.0 %	S-817A42APF-CVFTFG	S-817A42ANB-CVF-T2	—
4.3 V ± 2.0 %	S-817A43APF-CVGTFG	S-817A43ANB-CVG-T2	—
4.4 V ± 2.0 %	S-817A44APF-CVHTFG	S-817A44ANB-CVH-T2	—
4.5 V ± 2.0 %	S-817A45APF-CVITFG	S-817A45ANB-CVI-T2	—
4.6 V ± 2.0 %	S-817A46APF-CVJTFG	S-817A46ANB-CVJ-T2	—
4.7 V ± 2.0 %	S-817A47APF-CVKTFG	S-817A47ANB-CVK-T2	—
4.8 V ± 2.0 %	S-817A48APF-CVLTFG	S-817A48ANB-CVL-T2	—
4.9 V ± 2.0 %	S-817A49APF-CVMTFG	S-817A49ANB-CVM-T2	—
5.0 V ± 2.0 %	S-817A50APF-CVNTFG	S-817A50ANB-CVN-T2	—
5.1 V ± 2.0 %	S-817A51APF-CVOTFG	S-817A51ANB-CVO-T2	—
5.2 V ± 2.0 %	S-817A52APF-CVP TFG	S-817A52ANB-CVP-T2	—
5.3 V ± 2.0 %	S-817A53APF-CVQTFG	S-817A53ANB-CVQ-T2	—
5.4 V ± 2.0 %	S-817A54APF-CVRTFG	S-817A54ANB-CVR-T2	—
5.5 V ± 2.0 %	S-817A55APF-CVSTFG	S-817A55ANB-CVS-T2	—
5.6 V ± 2.0 %	S-817A56APF-CVTFG	S-817A56ANB-CVT-T2	—
5.7 V ± 2.0 %	S-817A57APF-CVUTFG	S-817A57ANB-CVU-T2	—
5.8 V ± 2.0 %	S-817A58APF-CVVTFG	S-817A58ANB-CVV-T2	—
5.9 V ± 2.0 %	S-817A59APF-CVWTFG	S-817A59ANB-CVW-T2	—
6.0 V ± 2.0 %	S-817A60APF-CVXTFG	S-817A60ANB-CVX-T2	—

**Remark** Please contact the SII marketing department for products with an output voltage over than those specified above.

**2.2 S-817B series**

**Table 2**

Output voltage	SOT-23-5	SOT-89-3	TO-92 <sup>*1</sup>
1.1 V ± 2.0 %	S-817B11AMC-CWA-T2	S-817B11AUA-CWA-T2	S-817B11AY-X
1.2 V ± 2.0 %	S-817B12AMC-CWB-T2	S-817B12AUA-CWB-T2	S-817B12AY-X
1.3 V ± 2.0 %	S-817B13AMC-CWC-T2	S-817B13AUA-CWC-T2	S-817B13AY-X
1.4 V ± 2.0 %	S-817B14AMC-CWD-T2	S-817B14AUA-CWD-T2	S-817B14AY-X
1.5 V ± 2.0 %	S-817B15AMC-CWE-T2	S-817B15AUA-CWE-T2	S-817B15AY-X
1.6 V ± 2.0 %	S-817B16AMC-CWF-T2	S-817B16AUA-CWF-T2	S-817B16AY-X
1.7 V ± 2.0 %	S-817B17AMC-CWG-T2	S-817B17AUA-CWG-T2	S-817B17AY-X
1.8 V ± 2.0 %	S-817B18AMC-CWH-T2	S-817B18AUA-CWH-T2	S-817B18AY-X
1.9 V ± 2.0 %	S-817B19AMC-CWI-T2	S-817B19AUA-CWI-T2	S-817B19AY-X
2.0 V ± 2.0 %	S-817B20AMC-CWJ-T2	S-817B20AUA-CWJ-T2	S-817B20AY-X
2.1 V ± 2.0 %	S-817B21AMC-CWK-T2	S-817B21AUA-CWK-T2	S-817B21AY-X
2.2 V ± 2.0 %	S-817B22AMC-CWL-T2	S-817B22AUA-CWL-T2	S-817B22AY-X
2.3 V ± 2.0 %	S-817B23AMC-CWM-T2	S-817B23AUA-CWM-T2	S-817B23AY-X
2.4 V ± 2.0 %	S-817B24AMC-CWN-T2	S-817B24AUA-CWN-T2	S-817B24AY-X
2.5 V ± 2.0 %	S-817B25AMC-CWO-T2	S-817B25AUA-CWO-T2	S-817B25AY-X
2.6 V ± 2.0 %	S-817B26AMC-CWP-T2	S-817B26AUA-CWP-T2	S-817B26AY-X
2.7 V ± 2.0 %	S-817B27AMC-CWQ-T2	S-817B27AUA-CWQ-T2	S-817B27AY-X
2.8 V ± 2.0 %	S-817B28AMC-CWR-T2	S-817B28AUA-CWR-T2	S-817B28AY-X
2.9 V ± 2.0 %	S-817B29AMC-CWS-T2	S-817B29AUA-CWS-T2	S-817B29AY-X
3.0 V ± 2.0 %	S-817B30AMC-CWT-T2	S-817B30AUA-CWT-T2	S-817B30AY-X
3.1 V ± 2.0 %	S-817B31AMC-CWU-T2	S-817B31AUA-CWU-T2	S-817B31AY-X
3.2 V ± 2.0 %	S-817B32AMC-CWV-T2	S-817B32AUA-CWV-T2	S-817B32AY-X
3.3 V ± 2.0 %	S-817B33AMC-CWW-T2	S-817B33AUA-CWW-T2	S-817B33AY-X
3.4 V ± 2.0 %	S-817B34AMC-CWX-T2	S-817B34AUA-CWX-T2	S-817B34AY-X
3.5 V ± 2.0 %	S-817B35AMC-CWY-T2	S-817B35AUA-CWY-T2	S-817B35AY-X
3.6 V ± 2.0 %	S-817B36AMC-CWZ-T2	S-817B36AUA-CWZ-T2	S-817B36AY-X
3.7 V ± 2.0 %	S-817B37AMC-CXA-T2	S-817B37AUA-CXA-T2	S-817B37AY-X
3.8 V ± 2.0 %	S-817B38AMC-CXB-T2	S-817B38AUA-CXB-T2	S-817B38AY-X
3.9 V ± 2.0 %	S-817B39AMC-CXC-T2	S-817B39AUA-CXC-T2	S-817B39AY-X
4.0 V ± 2.0 %	S-817B40AMC-CXD-T2	S-817B40AUA-CXD-T2	S-817B40AY-X
4.1 V ± 2.0 %	S-817B41AMC-CXE-T2	S-817B41AUA-CXE-T2	S-817B41AY-X
4.2 V ± 2.0 %	S-817B42AMC-CXF-T2	S-817B42AUA-CXF-T2	S-817B42AY-X
4.3 V ± 2.0 %	S-817B43AMC-CXG-T2	S-817B43AUA-CXG-T2	S-817B43AY-X
4.4 V ± 2.0 %	S-817B44AMC-CXH-T2	S-817B44AUA-CXH-T2	S-817B44AY-X
4.5 V ± 2.0 %	S-817B45AMC-CXI-T2	S-817B45AUA-CXI-T2	S-817B45AY-X
4.6 V ± 2.0 %	S-817B46AMC-CXJ-T2	S-817B46AUA-CXJ-T2	S-817B46AY-X
4.7 V ± 2.0 %	S-817B47AMC-CXK-T2	S-817B47AUA-CXK-T2	S-817B47AY-X
4.8 V ± 2.0 %	S-817B48AMC-CXL-T2	S-817B48AUA-CXL-T2	S-817B48AY-X
4.9 V ± 2.0 %	S-817B49AMC-CXM-T2	S-817B49AUA-CXM-T2	S-817B49AY-X
5.0 V ± 2.0 %	S-817B50AMC-CXN-T2	S-817B50AUA-CXN-T2	S-817B50AY-X
5.1 V ± 2.0 %	S-817B51AMC-CXO-T2	S-817B51AUA-CXO-T2	S-817B51AY-X
5.2 V ± 2.0 %	S-817B52AMC-CXP-T2	S-817B52AUA-CXP-T2	S-817B52AY-X
5.3 V ± 2.0 %	S-817B53AMC-CXQ-T2	S-817B53AUA-CXQ-T2	S-817B53AY-X
5.4 V ± 2.0 %	S-817B54AMC-CXR-T2	S-817B54AUA-CXR-T2	S-817B54AY-X
5.5 V ± 2.0 %	S-817B55AMC-CXS-T2	S-817B55AUA-CXS-T2	S-817B55AY-X
5.6 V ± 2.0 %	S-817B56AMC-CXT-T2	S-817B56AUA-CXT-T2	S-817B56AY-X
5.7 V ± 2.0 %	S-817B57AMC-CXU-T2	S-817B57AUA-CXU-T2	S-817B57AY-X
5.8 V ± 2.0 %	S-817B58AMC-CXV-T2	S-817B58AUA-CXV-T2	S-817B58AY-X
5.9 V ± 2.0 %	S-817B59AMC-CXW-T2	S-817B59AUA-CXW-T2	S-817B59AY-X
6.0 V ± 2.0 %	S-817B60AMC-CXX-T2	S-817B60AUA-CXX-T2	S-817B60AY-X

\*1. X changes according to the packing form in TO-92.  
 B: Bulk, T: Tape and Reel, Z: Tape and ammo.

### ■ Pin Configurations

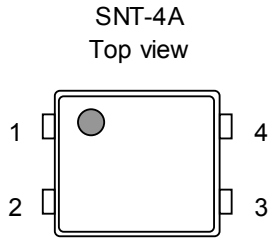

**Figure 3**

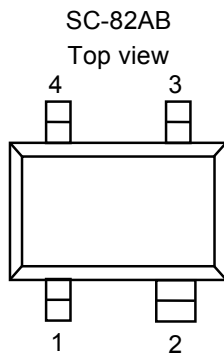

**Figure 4**

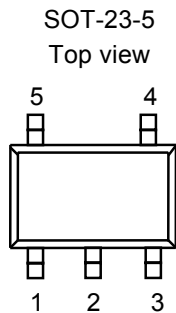

**Figure 5**

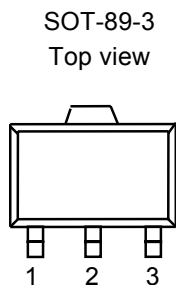

**Figure 6**

**Table 3**

Pin No.	Symbol	Description
1	VOUT	Output voltage pin
2	VIN	Input voltage pin
3	VSS	GND pin
4	NC <sup>*1</sup>	No connection

\*1. The NC pin is electrically open.  
The NC pin can be connected to VIN or VSS.

**Table 4**

Pin No.	Symbol	Description
1	VSS	GND pin
2	VIN	Input voltage pin
3	VOUT	Output voltage pin
4	NC <sup>*1</sup>	No connection

\*1. The NC pin is electrically open.  
The NC pin can be connected to VIN or VSS.

**Table 5**

Pin No.	Symbol	Description
1	VSS	GND pin
2	VIN	Input voltage pin
3	VOUT	Output voltage pin
4	NC <sup>*1</sup>	No connection
5	NC <sup>*1</sup>	No connection

\*1. The NC pin is electrically open.  
The NC pin can be connected to VIN or VSS.

**Table 6**

Pin No.	Symbol	Description
1	VSS	GND pin
2	VIN	Input voltage pin
3	VOUT	Output voltage pin

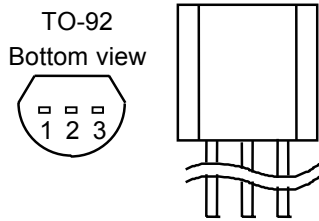

**Figure 7**

**Table 7**

Pin No.	Symbol	Description
1	VSS	GND pin
2	VIN	Input voltage pin
3	VOU	Output voltage pin

■ **Absolute Maximum Ratings**

**Table 8**

(Ta=25°C unless otherwise specified)

Item	Symbol	Absolute Maximum Rating		Units
Input voltage	V <sub>IN</sub>	V <sub>SS</sub> -0.3 to V <sub>SS</sub> +12		V
Output voltage	V <sub>OU</sub>	V <sub>SS</sub> -0.3 to V <sub>IN</sub> +0.3		V
Power dissipation	P <sub>D</sub>	SNT-4A	300 <sup>*1</sup>	mW
		SC-82AB	150	
		SOT-23-5	250	
		SOT-89-3	500	
		TO-92	400	
Operating temperature range	Topr	-40 to +85		°C
Storage temperature	Tstg	-40 to +125		°C

\*1. At mounted on JEDEC high heat dissipation printed circuit board

**Caution** The absolute maximum ratings are rated values exceeding which the product could suffer physical damage. These values must therefore not be exceeded under any conditions.



**SUPER-SMALL PACKAGE CMOS VOLTAGE REGULATOR**  
**S-817 Series**

Rev.3.0\_00

**■ Electrical Characteristics**

**1. S-817A series**

**Table 9**

(Ta=25°C unless otherwise specified)

Item	Symbol	Conditions	Min.	Typ.	Max.	Units	Measurement circuits	
Output voltage *1	$V_{OUT(E)}$	$V_{IN}=V_{OUT(S)}+2\text{ V}$ , $I_{OUT}=10\text{ mA}$	$\frac{V_{OUT(S)}}{\times 0.98}$	$V_{OUT(S)}$	$\frac{V_{OUT(S)}}{\times 1.02}$	V	1	
Output current *2	$I_{OUT}$	$V_{OUT(S)}+2\text{ V} \leq V_{IN} \leq 10\text{ V}$	$1.1\text{ V} \leq V_{OUT(S)} \leq 1.9\text{ V}$	20	–	–	mA	3
			$2.0\text{ V} \leq V_{OUT(S)} \leq 2.9\text{ V}$	35	–	–		
			$3.0\text{ V} \leq V_{OUT(S)} \leq 3.9\text{ V}$	50	–	–		
			$4.0\text{ V} \leq V_{OUT(S)} \leq 4.9\text{ V}$	65	–	–		
			$5.0\text{ V} \leq V_{OUT(S)} \leq 6.0\text{ V}$	75	–	–		
Dropout voltage *3	$V_{drop}$	$I_{OUT} = 10\text{ mA}$	$1.1\text{ V} \leq V_{OUT(S)} \leq 1.4\text{ V}$	–	0.92	1.58	V	1
			$1.5\text{ V} \leq V_{OUT(S)} \leq 1.9\text{ V}$	–	0.58	0.99		
			$2.0\text{ V} \leq V_{OUT(S)} \leq 2.4\text{ V}$	–	0.40	0.67		
			$2.5\text{ V} \leq V_{OUT(S)} \leq 2.9\text{ V}$	–	0.31	0.51		
			$3.0\text{ V} \leq V_{OUT(S)} \leq 3.4\text{ V}$	–	0.25	0.41		
			$3.5\text{ V} \leq V_{OUT(S)} \leq 3.9\text{ V}$	–	0.22	0.35		
			$4.0\text{ V} \leq V_{OUT(S)} \leq 4.4\text{ V}$	–	0.19	0.30		
			$4.5\text{ V} \leq V_{OUT(S)} \leq 4.9\text{ V}$	–	0.18	0.27		
			$5.0\text{ V} \leq V_{OUT(S)} \leq 5.4\text{ V}$	–	0.16	0.25		
Line regulation 1	$\Delta V_{OUT1}$	$V_{OUT(S)} + 1\text{ V} \leq V_{IN} \leq 10\text{ V}$ , $I_{OUT} = 1\text{ mA}$	–	5	20	mV		
			–	5	20			
Line regulation 2	$\Delta V_{OUT2}$	$V_{OUT(S)} + 1\text{ V} \leq V_{IN} \leq 10\text{ V}$ , $I_{OUT} = 1\text{ }\mu\text{A}$	–	5	20			
Load regulation	$\Delta V_{OUT3}$	$V_{IN}=V_{OUT(S)}+2\text{ V}$	$1.1\text{ V} \leq V_{OUT(S)} \leq 1.9\text{ V}$ , $1\text{ }\mu\text{A} \leq I_{OUT} \leq 10\text{ mA}$	–	5	20		
			$2.0\text{ V} \leq V_{OUT(S)} \leq 2.9\text{ V}$ , $1\text{ }\mu\text{A} \leq I_{OUT} \leq 20\text{ mA}$	–	10	30		
			$3.0\text{ V} \leq V_{OUT(S)} \leq 3.9\text{ V}$ , $1\text{ }\mu\text{A} \leq I_{OUT} \leq 30\text{ mA}$	–	20	45		
			$4.0\text{ V} \leq V_{OUT(S)} \leq 4.9\text{ V}$ , $1\text{ }\mu\text{A} \leq I_{OUT} \leq 40\text{ mA}$	–	25	65		
			$5.0\text{ V} \leq V_{OUT(S)} \leq 6.0\text{ V}$ , $1\text{ }\mu\text{A} \leq I_{OUT} \leq 50\text{ mA}$	–	35	80		
Output voltage temperature coefficient *4	$\frac{\Delta V_{OUT}}{\Delta Ta \cdot V_{OUT}}$	$V_{IN} = V_{OUT(S)} + 1\text{ V}$ , $I_{OUT} = 10\text{ mA}$ , $-40^\circ\text{C} \leq Ta \leq 85^\circ\text{C}$	–	$\pm 100$	–	ppm/ °C		
Current consumption	$I_{SS}$	$V_{IN} = V_{OUT(S)} + 2\text{ V}$ , no load	–	1.2	2.5	$\mu\text{A}$	2	
Input voltage	$V_{IN}$	–	–	–	10	V	1	
Short current limit	$I_{OS}$	$V_{IN} = V_{OUT(S)} + 2\text{ V}$ , $V_{OUT\text{ pin}} = 0\text{ V}$	–	40	–	mA	3	

\*1.  $V_{OUT(S)}$ : Specified output voltage

$V_{OUT(E)}$ : Effective output voltage

i.e., the output voltage when fixing  $I_{OUT}(=10\text{ mA})$  and inputting  $V_{OUT(S)}+2.0\text{ V}$ .

\*2. Output current at which output voltage becomes 95% of  $V_{OUT(E)}$  after gradually increasing output current.

\*3.  $V_{drop} = V_{IN1} - (V_{OUT(E)} \times 0.98)$ , where  $V_{IN1}$  is the Input voltage at which output voltage becomes 98% of  $V_{OUT(E)}$  after gradually decreasing input voltage.

\*4. Temperature change ratio for the output voltage [mV/°C] is calculated using the following equation.

$$\frac{\Delta V_{OUT}}{\Delta Ta} [\text{mV}/^\circ\text{C}]^{*1} = V_{OUT(S)} [\text{V}]^{*2} \times \frac{\Delta V_{OUT}}{\Delta Ta \cdot V_{OUT}} [\text{ppm}/^\circ\text{C}]^{*3} \div 1000$$

\*1. Temperature change ratio of the output voltage

\*2. Specified output voltage

\*3. Output voltage temperature coefficient

**2. S-817B series**

**Table 10**

(Ta=25°C unless otherwise specified)

Item	Symbol	Conditions	Min.	Typ.	Max.	Units	Measurement circuits	
Output voltage *1	$V_{OUT(E)}$	$V_{IN}=V_{OUT(S)}+2\text{ V}$ , $I_{OUT}=10\text{ mA}$	$V_{OUT(S)} \times 0.98$	$V_{OUT(S)}$	$V_{OUT(S)} \times 1.02$	V	1	
Output current *2	$I_{OUT}$	$V_{OUT(S)}+2\text{ V} \leq V_{IN} \leq 10\text{ V}$	$1.1\text{ V} \leq V_{OUT(S)} \leq 1.9\text{ V}$	20	—	—	mA	3
			$2.0\text{ V} \leq V_{OUT(S)} \leq 2.9\text{ V}$	35	—	—		
			$3.0\text{ V} \leq V_{OUT(S)} \leq 3.9\text{ V}$	50	—	—		
			$4.0\text{ V} \leq V_{OUT(S)} \leq 4.9\text{ V}$	65	—	—		
			$5.0\text{ V} \leq V_{OUT(S)} \leq 6.0\text{ V}$	75	—	—		
Dropout voltage *3	$V_{drop}$	$I_{OUT} = 10\text{ mA}$	$1.1\text{ V} \leq V_{OUT(S)} \leq 1.4\text{ V}$	—	0.92	1.58	V	1
			$1.5\text{ V} \leq V_{OUT(S)} \leq 1.9\text{ V}$	—	0.58	0.99		
			$2.0\text{ V} \leq V_{OUT(S)} \leq 2.4\text{ V}$	—	0.40	0.67		
			$2.5\text{ V} \leq V_{OUT(S)} \leq 2.9\text{ V}$	—	0.31	0.51		
			$3.0\text{ V} \leq V_{OUT(S)} \leq 3.4\text{ V}$	—	0.25	0.41		
			$3.5\text{ V} \leq V_{OUT(S)} \leq 3.9\text{ V}$	—	0.22	0.35		
			$4.0\text{ V} \leq V_{OUT(S)} \leq 4.4\text{ V}$	—	0.19	0.30		
			$4.5\text{ V} \leq V_{OUT(S)} \leq 4.9\text{ V}$	—	0.18	0.27		
			$5.0\text{ V} \leq V_{OUT(S)} \leq 5.4\text{ V}$	—	0.16	0.25		
Line regulation 1	$\Delta V_{OUT1}$	$V_{OUT(S)} + 1\text{ V} \leq V_{IN} \leq 10\text{ V}$ , $I_{OUT} = 1\text{ mA}$	—	5	20	mV		
Line regulation 2	$\Delta V_{OUT2}$	$V_{OUT(S)} + 1\text{ V} \leq V_{IN} \leq 10\text{ V}$ , $I_{OUT} = 1\text{ }\mu\text{A}$	—	5	20			
Load regulation	$\Delta V_{OUT3}$	$V_{IN}=V_{OUT(S)}+2\text{ V}$	—	5	20			
			$1.1\text{ V} \leq V_{OUT(S)} \leq 1.9\text{ V}$ , $1\text{ }\mu\text{A} \leq I_{OUT} \leq 10\text{ mA}$	—	10	30		
			$2.0\text{ V} \leq V_{OUT(S)} \leq 2.9\text{ V}$ , $1\text{ }\mu\text{A} \leq I_{OUT} \leq 20\text{ mA}$	—	20	45		
			$3.0\text{ V} \leq V_{OUT(S)} \leq 3.9\text{ V}$ , $1\text{ }\mu\text{A} \leq I_{OUT} \leq 30\text{ mA}$	—	25	65		
			$4.0\text{ V} \leq V_{OUT(S)} \leq 4.9\text{ V}$ , $1\text{ }\mu\text{A} \leq I_{OUT} \leq 40\text{ mA}$	—	35	80		
			$5.0\text{ V} \leq V_{OUT(S)} \leq 6.0\text{ V}$ , $1\text{ }\mu\text{A} \leq I_{OUT} \leq 50\text{ mA}$	—	—	—		
Output voltage temperature coefficient *4	$\frac{\Delta V_{OUT}}{\Delta Ta \cdot V_{OUT}}$	$V_{IN} = V_{OUT(S)} + 1\text{ V}$ , $I_{OUT} = 10\text{ mA}$ , $-40^\circ\text{C} \leq Ta \leq 85^\circ\text{C}$	—	$\pm 100$	—	ppm/ $^\circ\text{C}$		
Current consumption	$I_{SS}$	$V_{IN} = V_{OUT(S)} + 2\text{ V}$ , no load	—	1.2	2.5	$\mu\text{A}$	2	
Input voltage	$V_{IN}$	—	—	—	10	V	1	

\*1.  $V_{OUT(S)}$ : Specified output voltage

$V_{OUT(E)}$ : Effective output voltage

i.e., the output voltage when fixing  $I_{OUT}(=10\text{ mA})$  and inputting  $V_{OUT(S)}+2.0\text{ V}$ .

\*2. Output current at which output voltage becomes 95% of  $V_{OUT(E)}$  after gradually increasing output current.

\*3.  $V_{drop} = V_{IN1} - (V_{OUT(E)} \times 0.98)$ , where  $V_{IN1}$  is the Input voltage at which output voltage becomes 98% of  $V_{OUT(E)}$  after gradually decreasing input voltage.

\*4. Temperature change ratio for the output voltage [mV/ $^\circ\text{C}$ ] is calculated using the following equation.

$$\frac{\Delta V_{OUT}}{\Delta Ta} [\text{mV}/^\circ\text{C}]^{*1} = V_{OUT(S)}[\text{V}]^{*2} \times \frac{\Delta V_{OUT}}{\Delta Ta \cdot V_{OUT}} [\text{ppm}/^\circ\text{C}]^{*3} \div 1000$$

\*1. Temperature change ratio of the output voltage

\*2. Specified output voltage

\*3. Output voltage temperature coefficient

■ Measurement Circuits

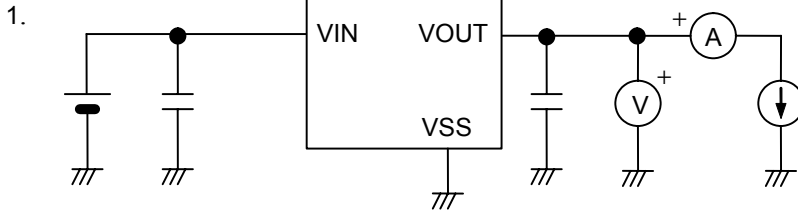

Figure 8

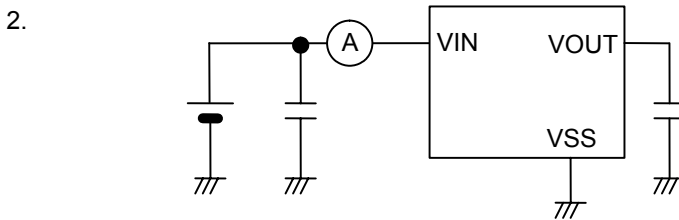

Figure 9

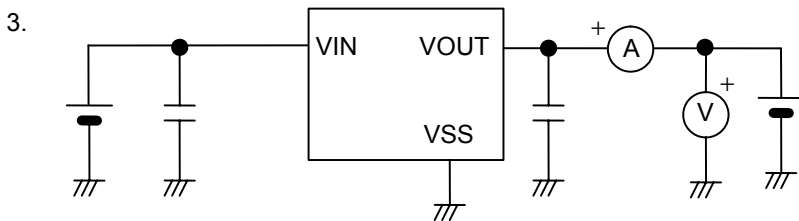
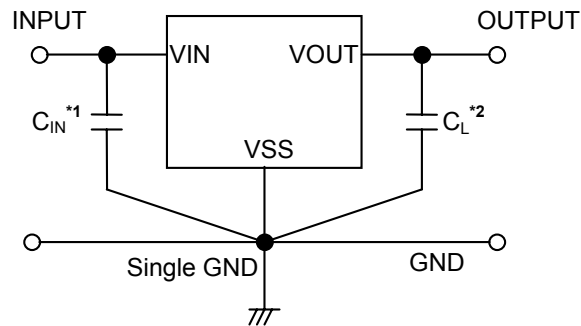

Figure 10

■ Standard Circuit



\*1.  $C_{IN}$  is a capacitor used to stabilize input.

\*2. A ceramic capacitor of 0.1  $\mu\text{F}$  or more can be used for  $C_L$ .

Figure 11

**Caution** The above connection diagram and constant will not guarantee successful operation. Perform through evaluation using the actual application to set the constant.

■ **Explanation of Terms**

**1. Low ESR**

ESR is the abbreviation for Equivalent Series Resistance.  
Low ESR output capacitors ( $C_L$ ) can be used in the S-817 Series.

**2. Output voltage ( $V_{OUT}$ )**

The accuracy of the output voltage is  $\pm 2.0\%$  guaranteed under the specified conditions for input voltage, which differs depending upon the product items, output current, and temperature.

**Caution** If the above conditions change, the output voltage value may vary and go out of the accuracy range of the output voltage. See the electrical characteristics and characteristics data for details.

**3. Line regulations 1 and 2 ( $\Delta V_{OUT1}$ ,  $\Delta V_{OUT2}$ )**

Indicate the input voltage dependencies of output voltage. That is, the values show how much the output voltage changes due to a change in the input voltage with the output current remained unchanged.

**4. Load regulation ( $\Delta V_{OUT3}$ )**

Indicates the output current dependencies of output voltage. That is, the values show how much the output voltage changes due to a change in the output current with the input voltage remained unchanged.

**5. Dropout voltage ( $V_{drop}$ )**

Indicates a difference between input voltage ( $V_{IN1}$ ) and output voltage when output voltage falls by 98% of  $V_{OUT(E)}$  by gradually decreasing the input voltage ( $V_{IN}$ ).

$$V_{drop} = V_{IN1} - [V_{OUT(E)} \times 0.98]$$

6. Temperature coefficient of output voltage  $\left( \frac{\Delta V_{OUT}}{\Delta T_a \bullet V_{OUT}} \right)$

The shadowed area in **Figure 12** is the range where  $V_{OUT}$  varies in the operating temperature range when the temperature coefficient of the output voltage is  $\pm 100$  ppm/ $^{\circ}$ C.

Ex. S-817A15 Typ.

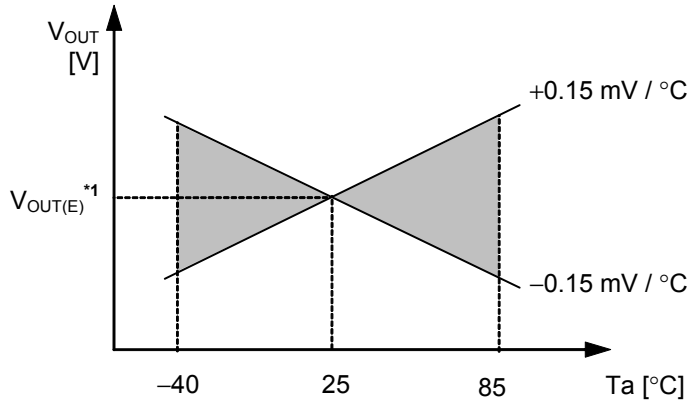

\*1.  $V_{OUT(E)}$  is the value of the output voltage measured at 25°C.

**Figure 12**

A change in the temperature of the output voltage [mV/ $^{\circ}$ C] is calculated using the following equation.

$$\frac{\Delta V_{OUT}}{\Delta T_a} [\text{mV}/^{\circ}\text{C}]^*1 = V_{OUT(S)} [\text{V}]^2 \times \frac{\Delta V_{OUT}}{\Delta T_a \bullet V_{OUT}} [\text{ppm}/^{\circ}\text{C}]^*3 \div 1000$$

- \*1. Change in temperature of output voltage
- \*2. Specified output voltage
- \*3. Output voltage temperature coefficient

■ **Operation**

**1. Basic Operation**

Figure 13 shows the block diagram of the S-817 Series.

The error amplifier compares the reference voltage ( $V_{ref}$ ) with  $V_{fb}$ , which is the output voltage resistance-divided by feedback resistors  $R_s$  and  $R_f$ . It supplies the output transistor with the gate voltage necessary to ensure a certain output voltage free of any fluctuations of input voltage and temperature.

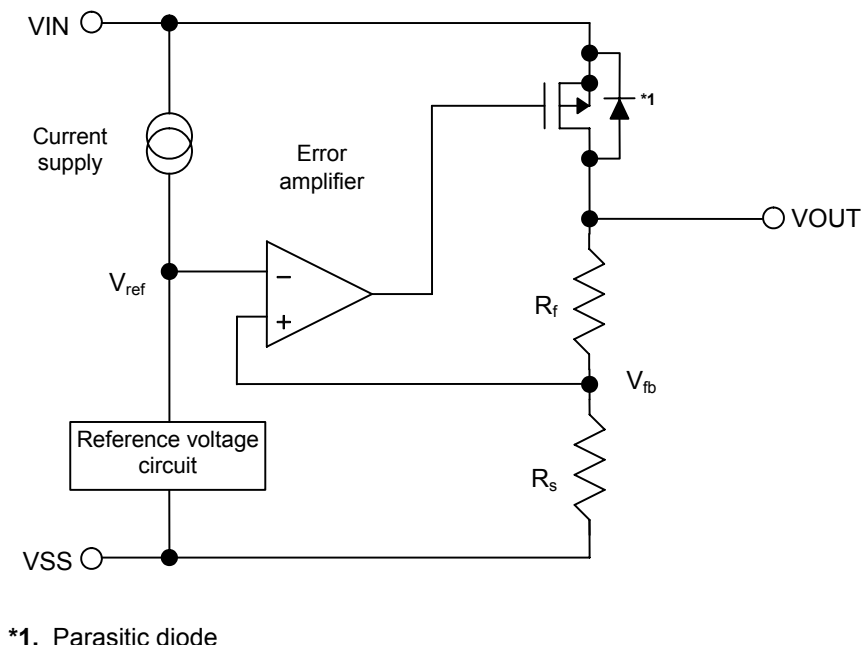

**Figure 13**

**2. Output Transistor**

The S-817 series uses a P-channel MOS FET as the output transistor.

Be sure that  $V_{OUT}$  does not exceed  $V_{IN}+0.3$  V to prevent the voltage regulator from being damaged due to inverse current flowing from VOUT pin through a parasitic diode to VIN pin.

**3. Short Circuit Protection**

The S-817A series incorporates a short circuit protection to protect the output transistor against short circuit between VOUT pin and VSS pin. Installation of the short-circuit protection which protects the output transistor against short-circuit between VOUT and VSS can be selected in the S-817A series. The short-circuit protection controls output current as shown in the “**Typical Characteristics 1.**”. Output Voltage versus Output Current, and suppresses output current at about 40 mA even if VOUT and VSS pins are short-circuited.

The short-circuit protection can not be a thermal protection at the same time. Attention should be paid to the Input voltage and the load current under the actual condition so as not to exceed the power dissipation of the package including the case for short-circuit.

When the output current is large and the difference between input and output voltage is large even if not shorted, the short-circuit protection may work and the output current is suppressed to the specified value. In addition, S-817B series is removing a short-circuit protection, and is the product which enabled it to pass large current.

## ■ Selection of Output Capacitor ( $C_L$ )

To stabilize operation against variation in output load, a capacitor ( $C_L$ ) must be mounted between  $V_{OUT}$  and  $V_{SS}$  in the S-817 series because the phase is compensated with the help of the internal phase compensation circuit and the ESR of the output capacitor.

When selecting a ceramic or an OS capacitor, capacitance should be 0.1  $\mu\text{F}$  or more, and when selecting a tantalum or an aluminum electrolytic capacitor, capacitance should be 0.1  $\mu\text{F}$  or more and ESR 30  $\Omega$  or less.

When an aluminum electrolytic capacitor is used attention should be especially paid to since the ESR of the aluminum electrolytic capacitor increases at low temperature and possibility of oscillation becomes large. Sufficient evaluation including temperature characteristics is indispensable. Overshoot and undershoot characteristics differ depending upon the type of the output capacitor. Refer to  $C_L$  dependencies in "■ Reference Data 1. Transient Response Characteristics".

## ■ Application Circuits

### 1. Output Current Boosting Circuit

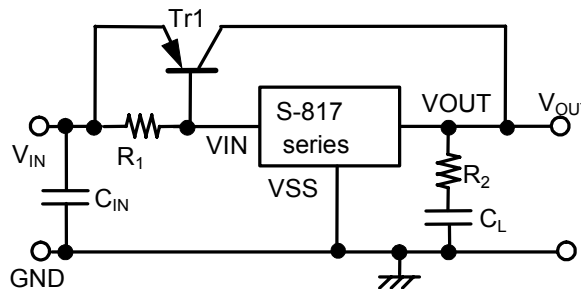

Figure 14

As shown in **Figure 14**, the output current can be boosted by externally attaching a PNP transistor. The base current of the PNP transistor is controlled so that output voltage ( $V_{OUT}$ ) goes the voltage specified in the S-817 Series when base-emitter voltage ( $V_{BE}$ ) necessary to turn on the PNP transistor is obtained between input voltage ( $V_{IN}$ ) and S-817 Series power source pin ( $V_{IN}$ ).

The following are tips and hints for selecting and ensuring optimum use of external parts

- PNP transistor ( $Tr1$ ):
  1. Set  $h_{FE}$  to approx. 100 to 400.
  2. Confirm that no problem occurs due to power dissipation under normal operation conditions.
- Resistor ( $R_1$ ):
 

Generally set  $R_1$  to 1  $\text{k}\Omega \div V_{OUT(S)}$  (the voltage specified in the S-817 Series) or more.
- Output capacitor ( $C_L$ ):
 

Output capacitor ( $C_L$ ) is effective in minimizing output fluctuation at powering on or due to power or load fluctuation, but oscillation might occur. Always connect resistor  $R_2$  in series to output capacitor  $C_L$ .
- Resistor ( $R_2$ ): Set  $R_2$  to 2  $\Omega \times V_{OUT(S)}$  or more.
- DO NOT attach a capacitor between the S-817 Series power source ( $V_{IN}$ ) and GND pins or between base and emitter of the PNP transistor to avoid oscillation.
- To improve transient response characteristics of the output current boosting circuit shown in **Figure 14**, check that no problem occurs due to output fluctuation at powering on or due to power or load fluctuation under normal operating conditions.
- Pay attention to the short current limit circuit incorporated into the S-817 Series because it does not function as a shortcircuiting protection circuit for this boosting circuit.

The following graphs show the examples of input-output voltage characteristics ( $T_a=25^\circ\text{C}$ , typ.) in the output current boosting circuit:

**1. 1 S-817A11ANB/S-817B11AMC**

Tr1 : 2SA1213Y,  $R_1$  : 1 k $\Omega$ ,  $C_L$  : 10  $\mu\text{F}$ ,  
 $R_2$  : 2  $\Omega$

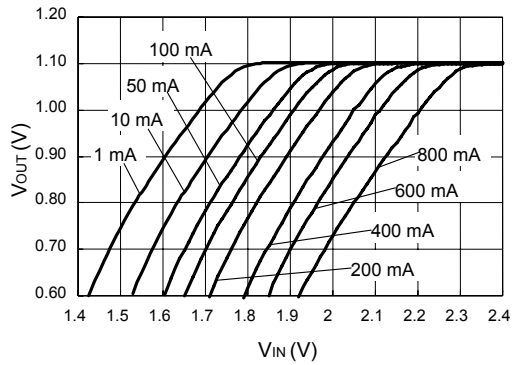

**1. 2 S-817A50ANB/S-817B50AMC**

Tr1 : 2SA1213Y,  $R_1$  : 200  $\Omega$ ,  $C_L$  : 10  $\mu\text{F}$ ,  
 $R_2$  : 10  $\Omega$

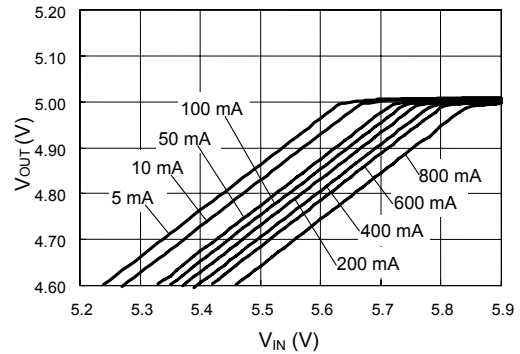

**2. Constant Current Circuit**

**2. 1 Constant Current Circuit**

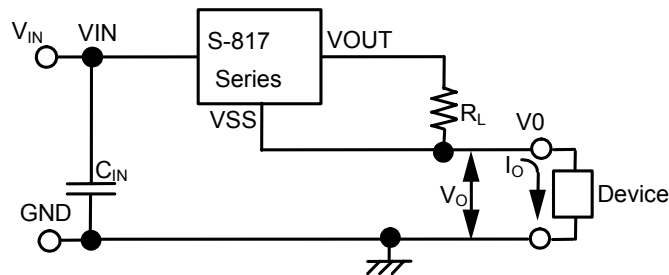

Figure 15

**2. 2 Constant Current Boosting Circuit**

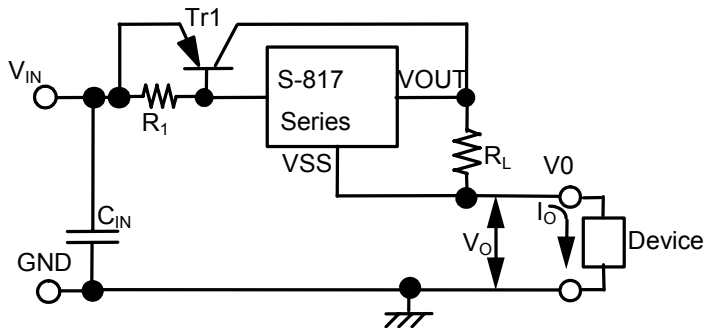

Figure 16



The S-817 Series can be configured as a constant current circuit. Refer to **Figure 15 and 16**.  
 Constant amperage ( $I_O$ ) is calculated using the following equation ( $V_{OUT(E)}$ : Effective output voltage):  

$$I_O = (V_{OUT(E)} \div R_L) + I_{SS}$$

Please note that it is impossible to set constant amperage  $I_O$  in case of circuit (1) of **Figure 15** to the value exceeding the drive ability of the S-817.

However, circuit (2) of **Figure 16** is an example to set constant amperage to the value exceeding the drive ability of the S-817. Circuit (2) incorporates a current boosting circuit. The maximum input voltage of the constant current circuit is the value obtained by adding 10 V to voltage of the device ( $V_O$ ). It is not recommended to attach a capacitor between the S-817 power source  $V_{IN}$  and  $V_{SS}$  pin or between output  $V_{OUT}$  and  $V_{SS}$  pin because rush current flows at powering on. An example of input voltage between  $V_{IN}$  and  $V_O$  in circuit (2) vs.  $I_O$  current characteristics

**$V_{IN}$ ,  $V_O$  pins, Input voltage -  $I_O$  current**

S-817A11ANB, S-817B11AMC,  $T_r$  : 2SK1213Y,  $R_1$  : 1 k $\Omega$ ,  $V_O=2$  V

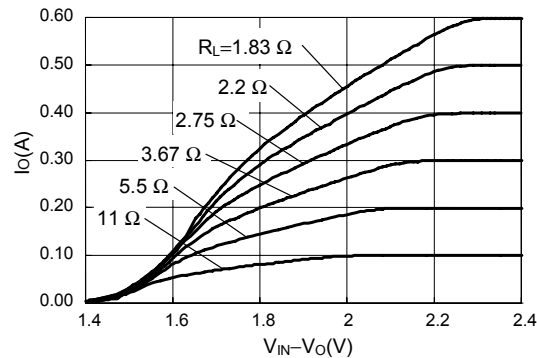

**3. Output Voltage Adjustment Circuit (Only for S817B Series (Product without short circuit protection))**

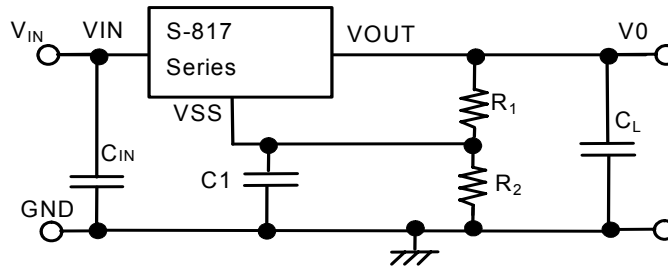

**Figure 17**

The output voltage can be boosted by using the configuration shown in **Figure 17**. The output Voltage ( $V_O$ ) can be calculated using the following equation ( $V_{OUT(E)}$ :Effective output voltage):

$$V_O = V_{OUT(E)} \times (R_1 + R_2) \div R_1 + R_2 \times I_{SS}$$

Set  $R_1$  and  $R_2$  to high values of resistance so as not to be affected by current consumption ( $I_{SS}$ ).

Capacitor  $C_1$  is effective in minimizing output fluctuation at powering on or due to power or load fluctuation. Determine the optimum value on your actual device. But it is not also recommended to attach a capacitor between the S-817 Series power source  $V_{IN}$  and  $V_{SS}$  pin or between output  $V_{OUT}$  and  $V_{SS}$  pin because output fluctuation or oscillation at powering on might occur. As shown in **Figure 17**, a capacitor must be mounted between  $V_{IN}$  and  $GND$ , and between  $V_{OUT}$  and  $GND$ .

■ **Precautions**

- Wiring patterns for the  $V_{IN}$ ,  $V_{OUT}$  and  $GND$  pins should be designed so that the impedance is low. When mounting an output capacitor between the  $V_{OUT}$  and  $V_{SS}$  pins ( $C_L$ ) and a capacitor for stabilizing the input between  $V_{IN}$  and  $V_{SS}$  pins ( $C_{IN}$ ), the distance from the capacitors to these pins should be as short as possible.
- Note that the output voltage may increase when a series regulator is used at low load current (1.0  $\mu A$  or less).
- Generally a series regulator may cause oscillation, depending on the selection of external parts. The following conditions are recommended for this IC. However, be sure to perform sufficient evaluation under the actual usage conditions for selection, including evaluation of temperature characteristics.

Output capacitor ( $C_L$ ) :	0.1 $\mu F$ or more
Equivalent Series Resistance (ESR) :	30 $\Omega$ or less
Input series resistance ( $R_{IN}$ ) :	10 $\Omega$ or less

- The voltage regulator may oscillate when the impedance of the power supply is high and the input capacitor is small or an input capacitor is not connected.
- The application conditions for the input voltage, output voltage, and load current should not exceed the package power dissipation.
- Do not apply an electrostatic discharge to this IC that exceeds the performance ratings of the built-in electrostatic protection circuit.
- SII claims no responsibility for any disputes arising out of or in connection with any infringement by products including this IC of patents owned by a third party.

■ Typical Characteristics

1. Output Voltage vs. Output Current (when load current increases)

(a) S-817A Series

S-817A11A (Ta=25°C)

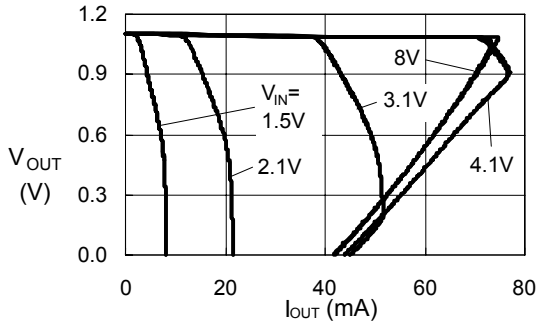

S-817A20A (Ta=25°C)

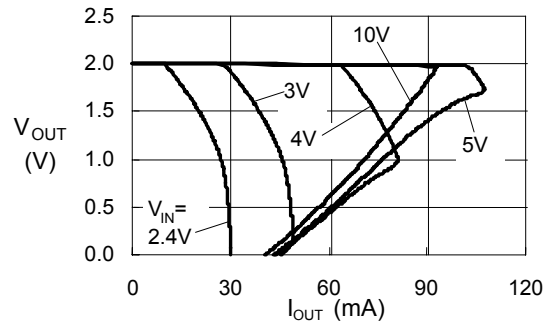

S-817A30A (Ta=25°C)

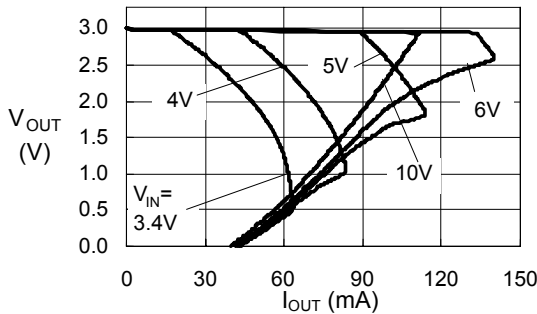

S-817A50A (Ta=25°C)

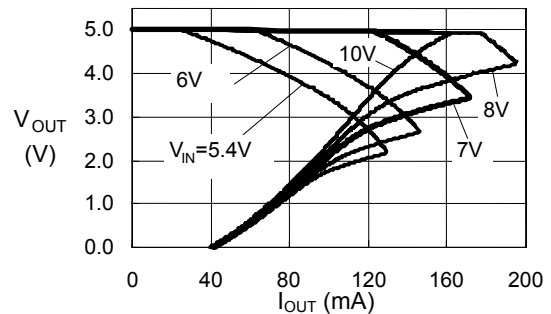

(b) S-817B series

S-817B11A (Ta=25°C)

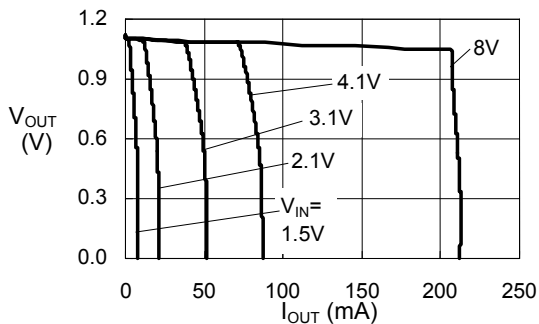

S-817B20A (Ta=25°C)

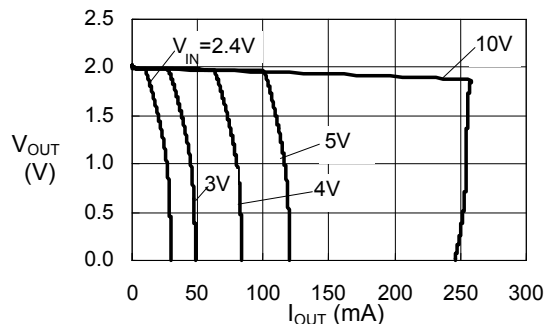

S-817B30A (Ta=25°C)

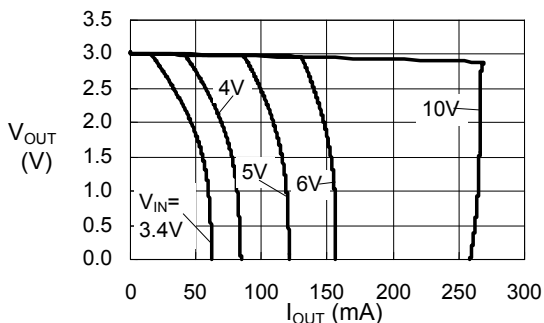

S-817B50A (Ta=25°C)

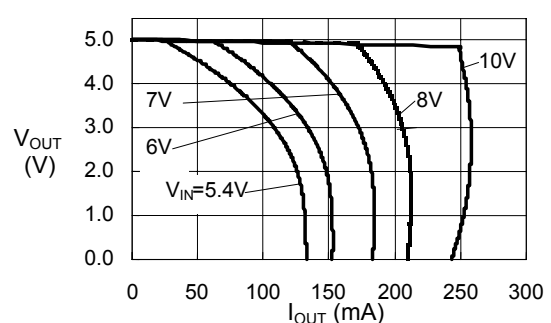

**2. Output Voltage vs. Input Voltage**

S-817A11A/S-817B11A (Ta=25°C)

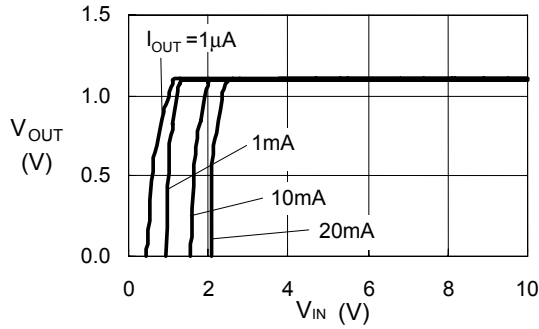

S-817A20A/S-817B20A (Ta=25°C)

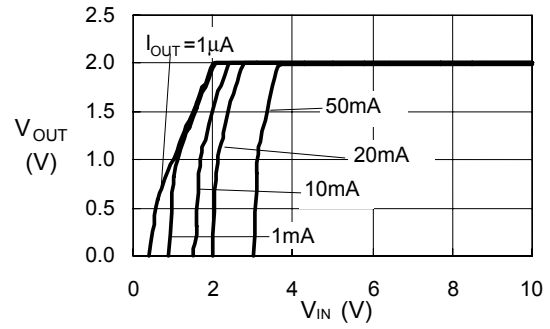

S-817A30A/S-817B30A (Ta=25°C)

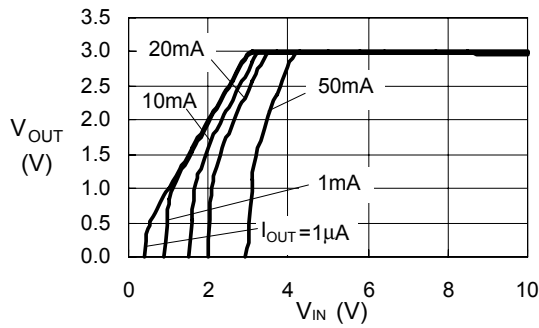

S-817A50A/S-817B50A (Ta=25°C)

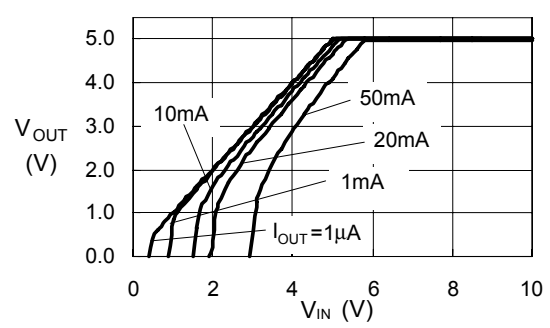

3. Maximum Output Current vs. Input Voltage

(a) S-817A Series

S-817A11A

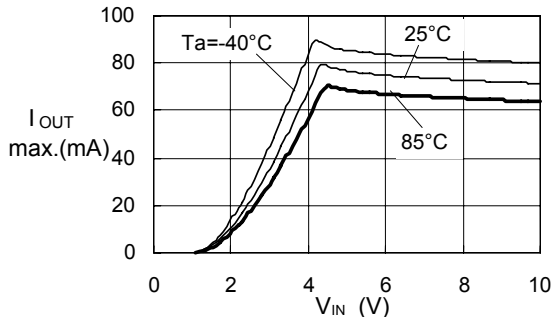

S-817A20A

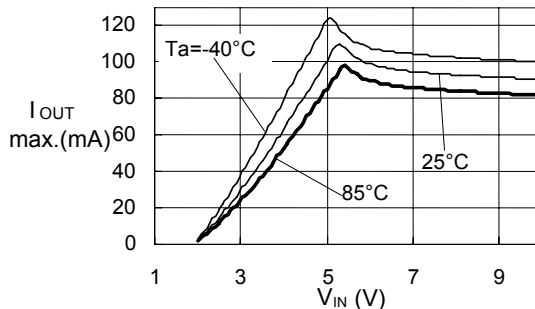

S-817A30A

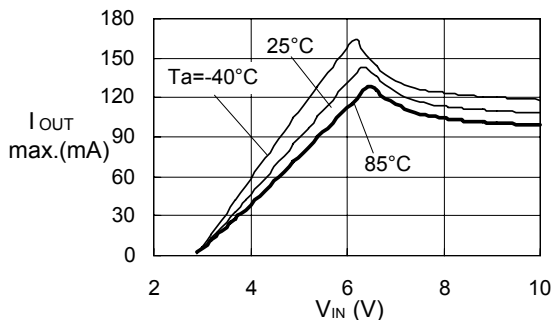

S-817A50A

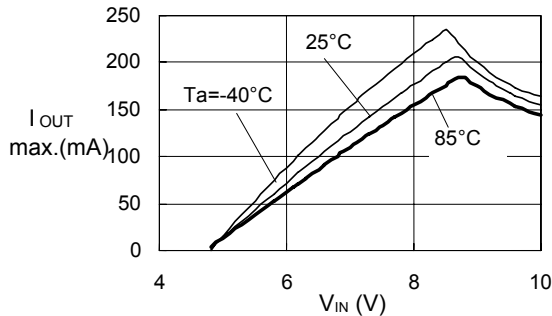

(b) S-817B Series

S-817B11A

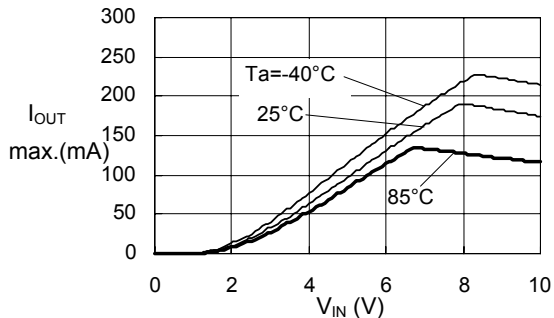

S-817B20A

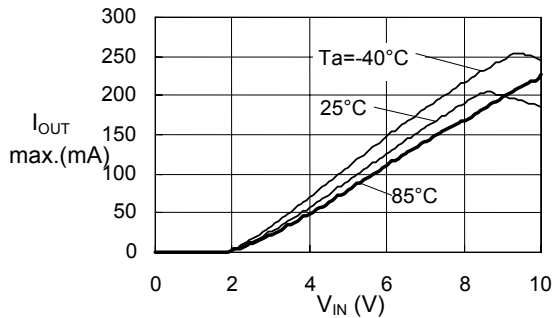

S-817B30A

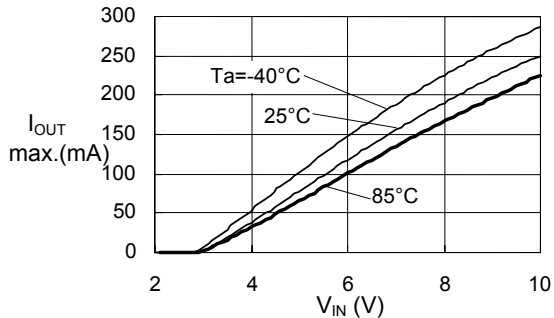

S-817B50A

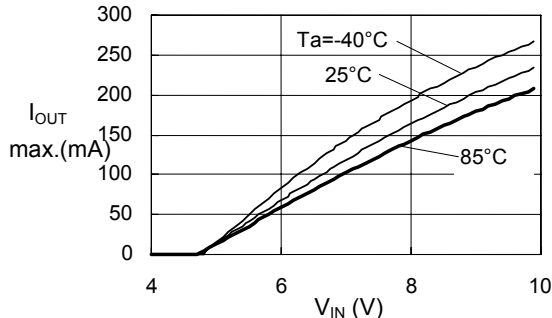

**4. Dropout Voltage vs. Output Current**

S-817A11A/S-817B11A

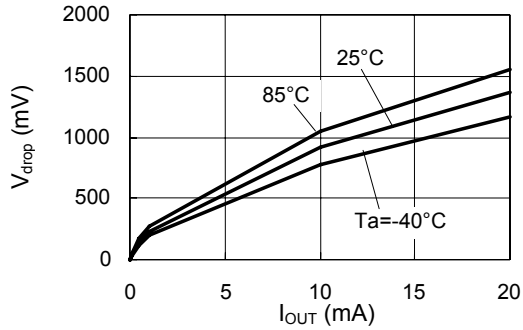

S-817A20A/S-817B20A

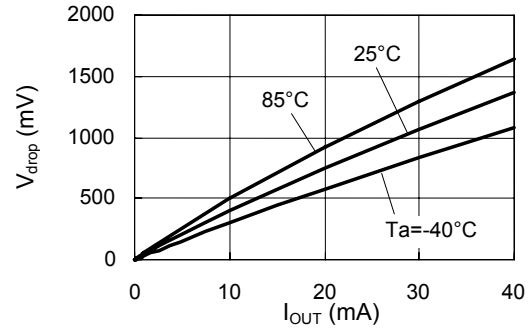

S-817A30A/S-817B30A

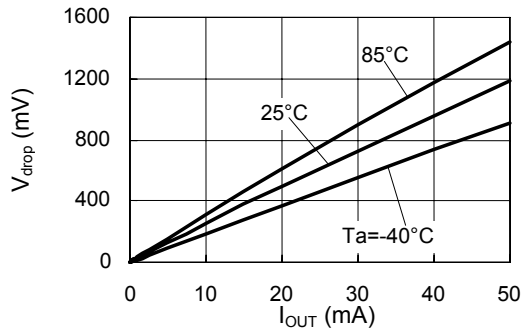

S-817A50A/S-817B50A

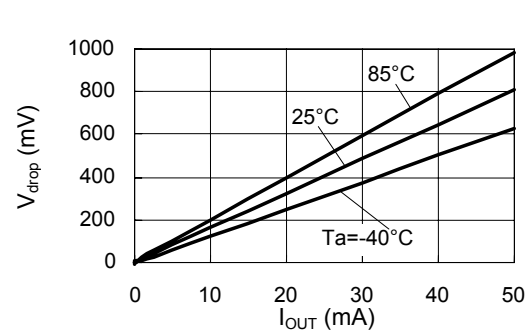

**5. Output Voltage vs. Ambient Temperature**

S-817A11A/S-817B11A  $V_{IN}=3.1V, I_{OUT}=10mA$

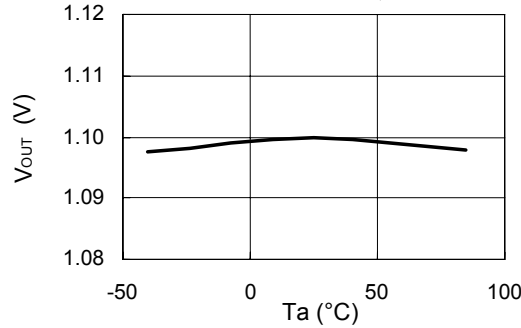

S-817A20A/S-817B20A  $V_{IN}=4V, I_{OUT}=10mA$

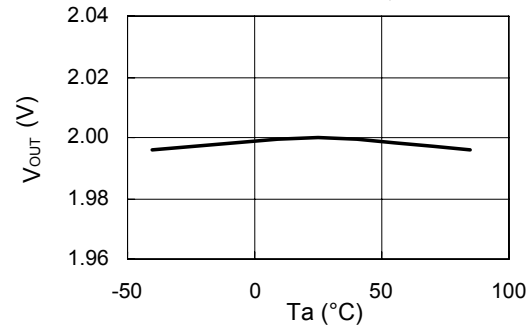

S-817A30A/S-817B30A  $V_{IN}=5V, I_{OUT}=10mA$

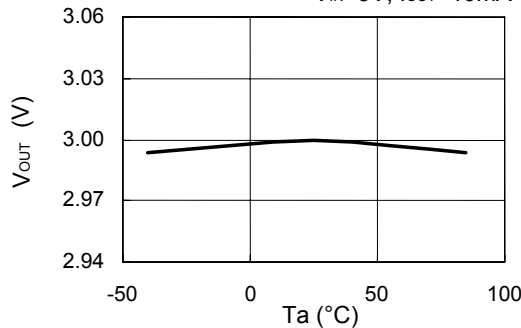

S-817A50A/S-817B50A  $V_{IN}=7V, I_{OUT}=10mA$

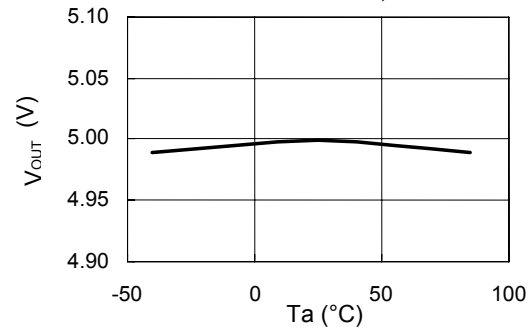

**6. Line Regulation 1 vs. Ambient Temperature**

S-817A11/20/30/50A  
S-817B11/20/30/50A  $V_{IN}=V_{OUT(S)}+1V \leftrightarrow 10V, I_{OUT}=1mA$

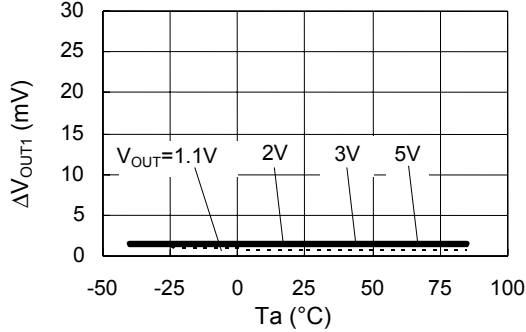

**7. Line Regulation 2 vs. Ambient Temperature**

S-817A11/20/30/50A  
S-817B11/20/30/50A  $V_{IN}=V_{OUT(S)}+1V \leftrightarrow 10V, I_{OUT}=1\mu A$

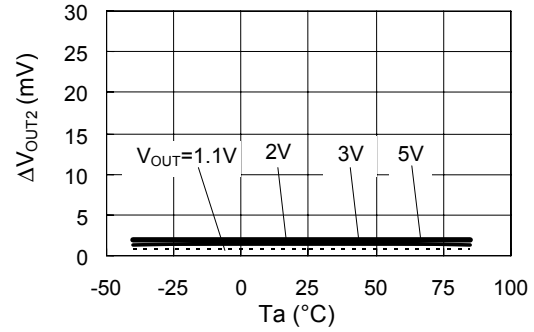

**8. Load Regulation vs. Ambient Temperature**

S-817A11/20/30/50A  
S-817B11/20/30/50A  $V_{IN}=V_{OUT(S)}+2V, I_{OUT}=1\mu A \leftrightarrow I_{OUT}$

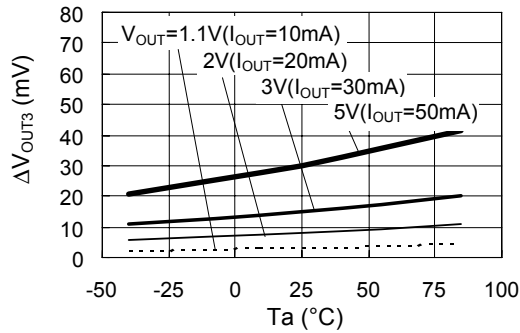

**9. Current Consumption vs. Input Voltage**

S-817A11A/S-817B11A

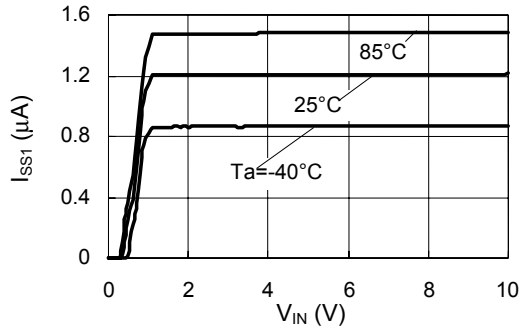

S-817A20A/S-817B20A

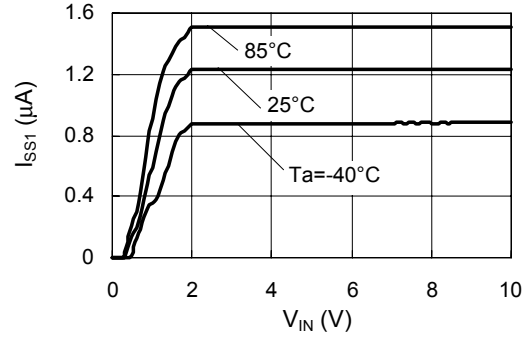

S-817A30A/S-817B30A

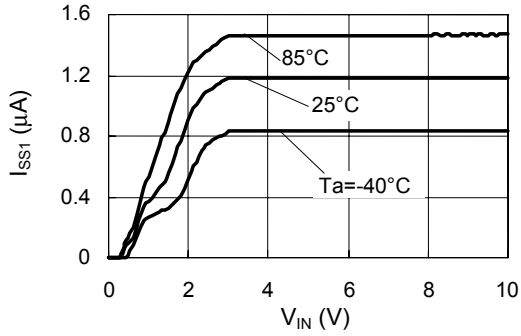

S-817A50A/S-817B50A

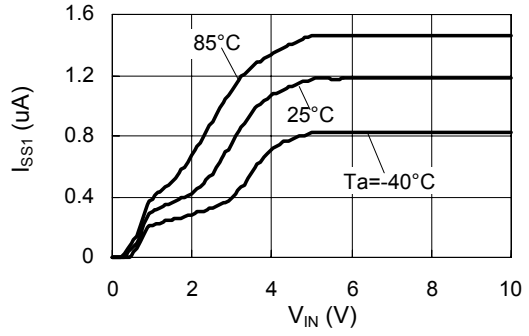



■ Reference Data

1. Transient Response Characteristics (Typical data: Ta=25 °C)

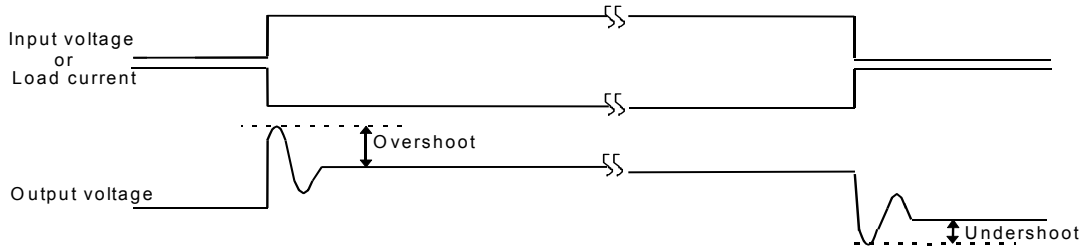

1.1 At powering on S-817A30A (when using a ceramic capacitor,  $C_L=1 \mu F$ )

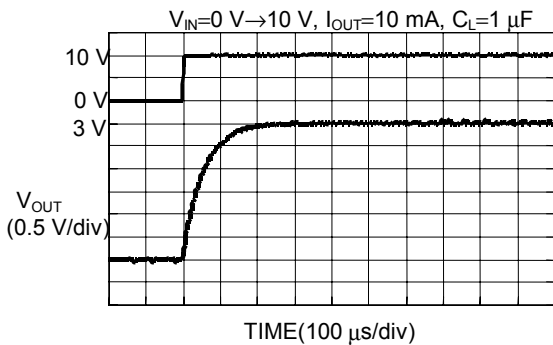

Load dependencies of overshoot at powering on

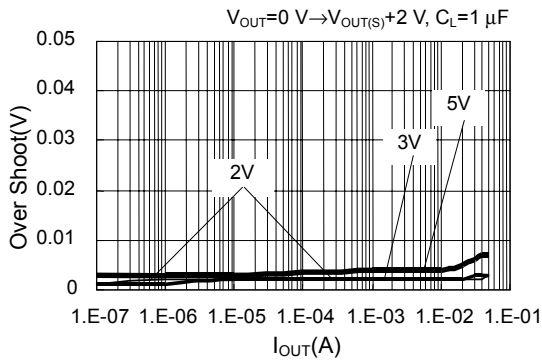

$C_L$  dependencies of overshoot at powering on

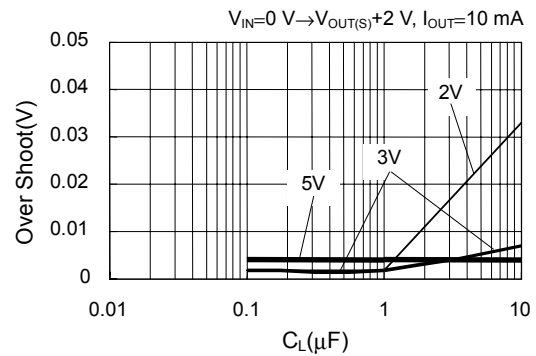

$V_{DD}$  dependencies of overshoot at powering on

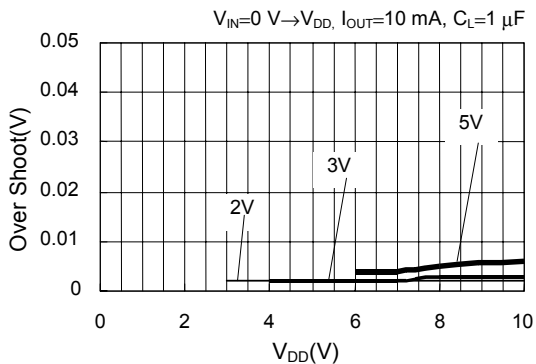

"Ta" dependencies of overshoot at powering on

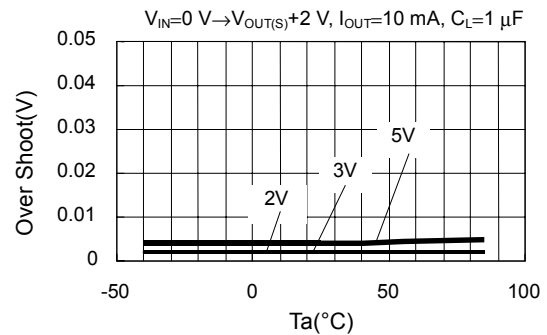

**1. 2 At powering on S-817B30A (when using a ceramic capacitor,  $C_L=1 \mu\text{F}$ )**

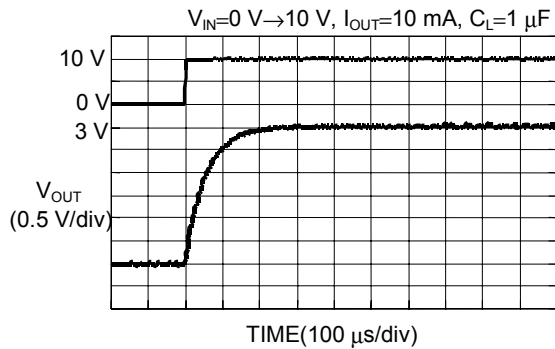

Load dependencies of overshoot at powering on

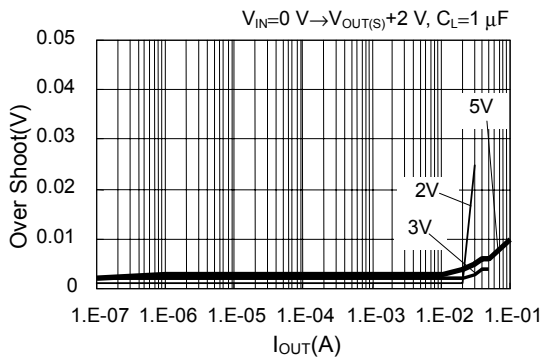

$C_L$  dependencies of overshoot at powering on

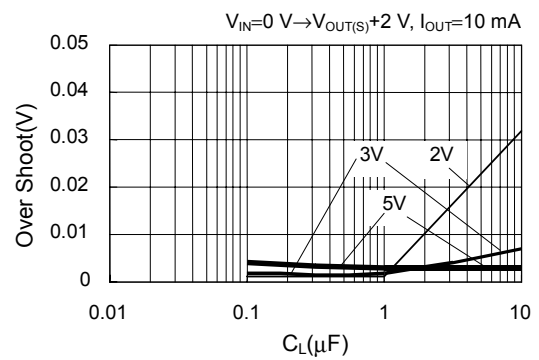

$V_{DD}$  dependencies of overshoot at powering on

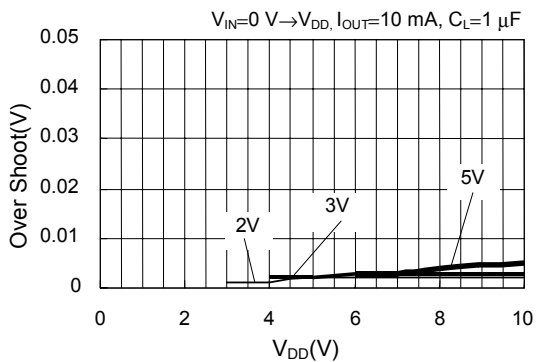

"Ta" dependencies of overshoot at powering on

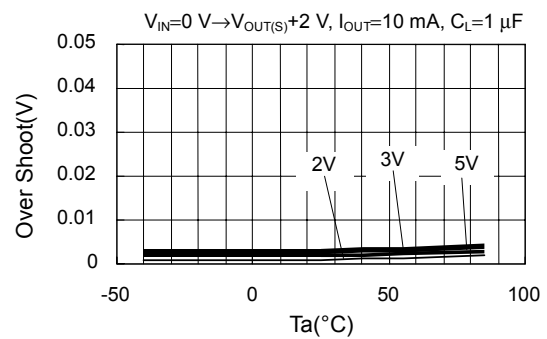

**1.3 Power fluctuation S-817A30A / S-817B30A (when using a ceramic capacitor,  $C_L=1 \mu\text{F}$ )**

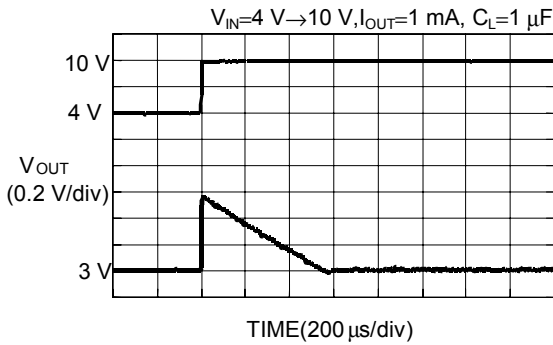

Load dependencies of overshoot at power fluctuation

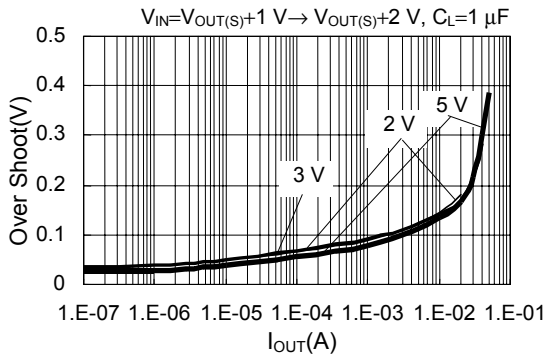

$C_L$  dependencies of overshoot at power fluctuation

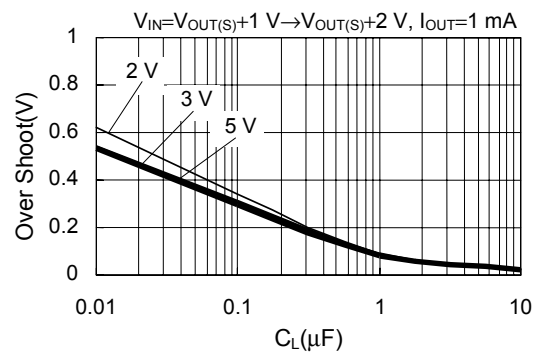

$V_{DD}$  dependencies of overshoot at power fluctuation

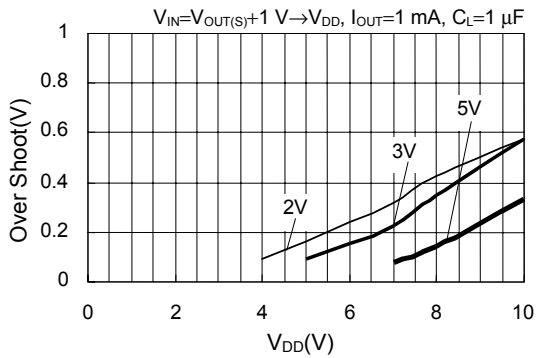

"Ta" dependencies of overshoot at power fluctuation

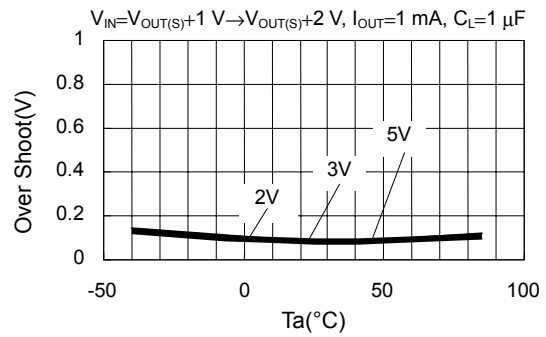

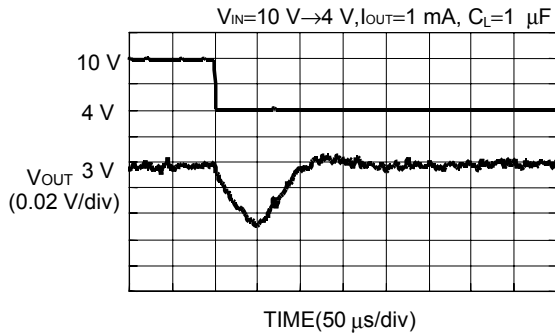

Load dependencies of undershoot at power fluctuation     $C_L$  dependencies of undershoot at power fluctuation

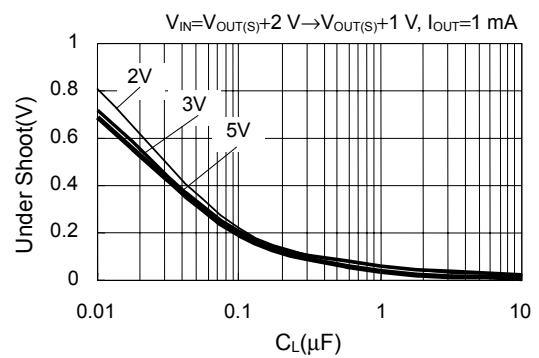
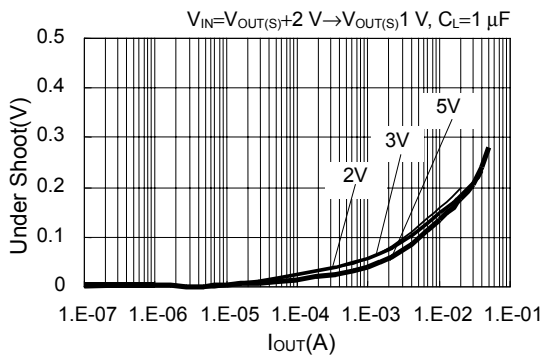

$V_{DD}$  dependencies of undershoot at power fluctuation    “ $T_a$ ” dependencies of undershoot at power fluctuation

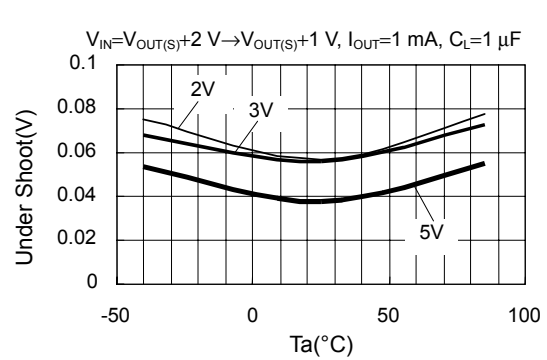
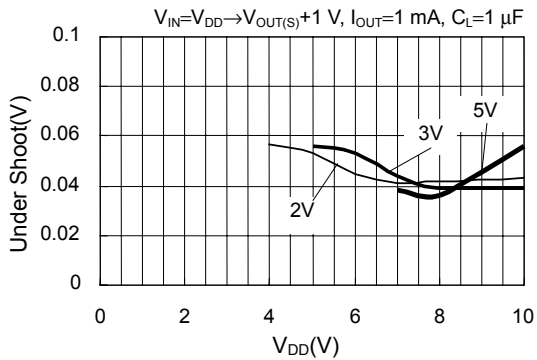

**1.4 Load fluctuation S-817A30A/S-817B30A (when using a ceramic capacitor,  $C_L=1\ \mu\text{F}$ )**

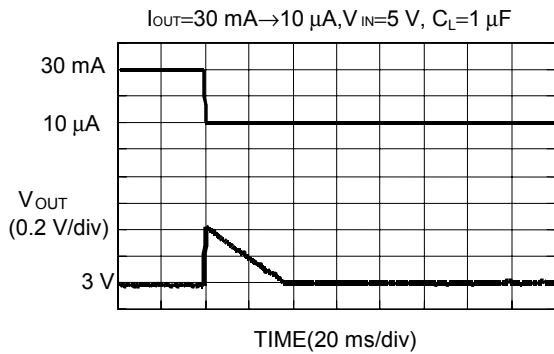

Load current dependencies of overshoot at load fluctuation

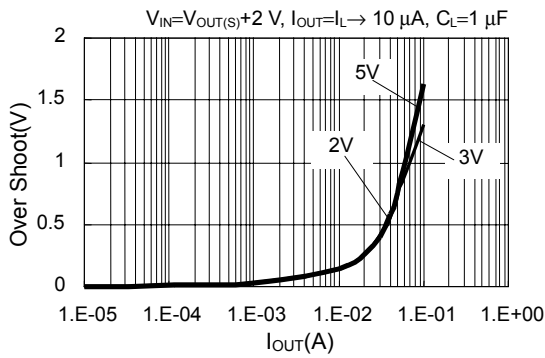

$C_L$  dependencies of overshoot at load fluctuation

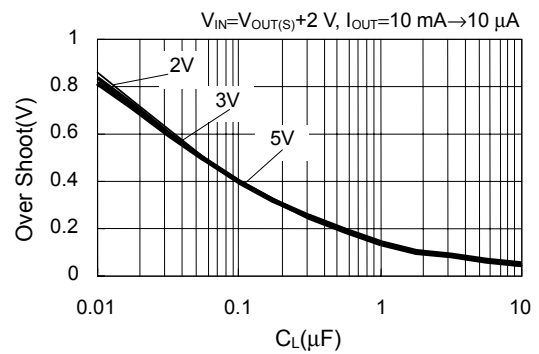

$V_{DD}$  dependencies of overshoot at load fluctuation

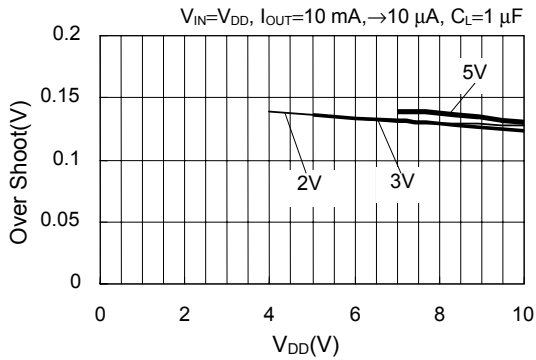

“Ta” dependencies of overshoot at load fluctuation

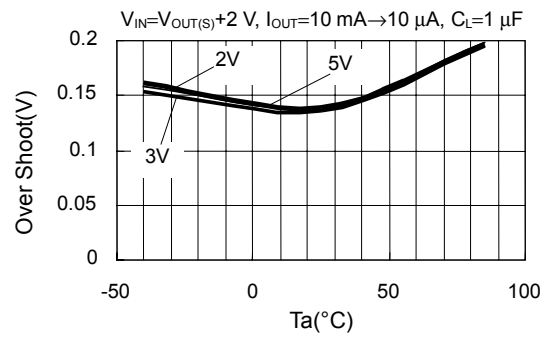

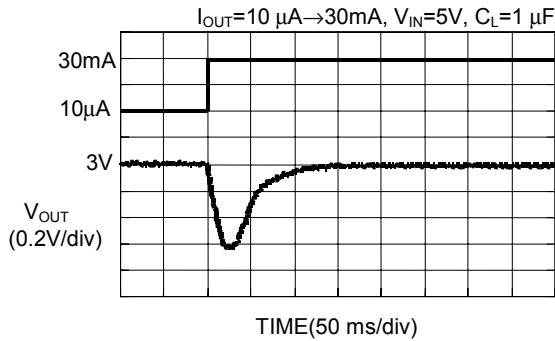

Load current dependencies of undershoot at load fluctuation

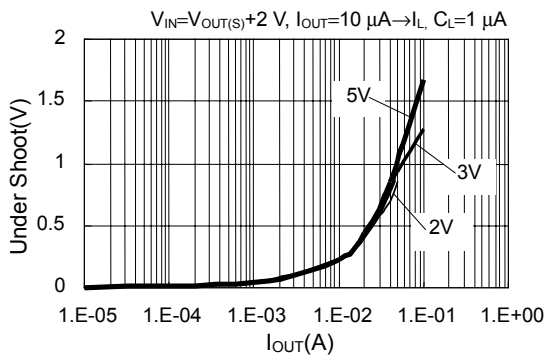

$C_L$  dependencies of undershoot at load fluctuation

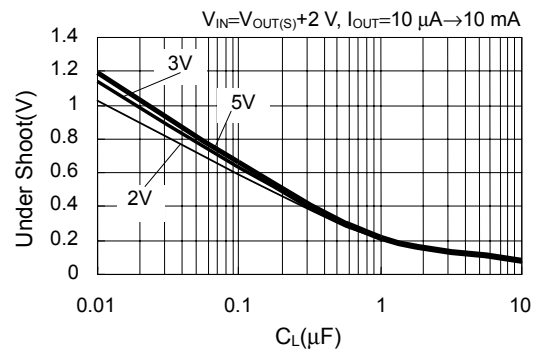

$V_{DD}$  dependencies of undershoot at load fluctuation

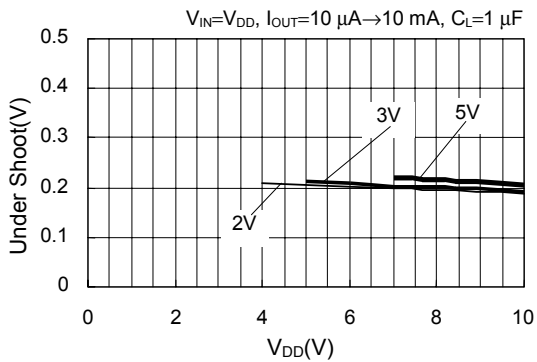

“Ta” dependencies of undershoot at load fluctuation

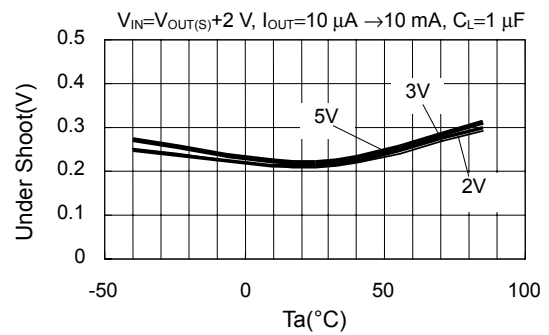

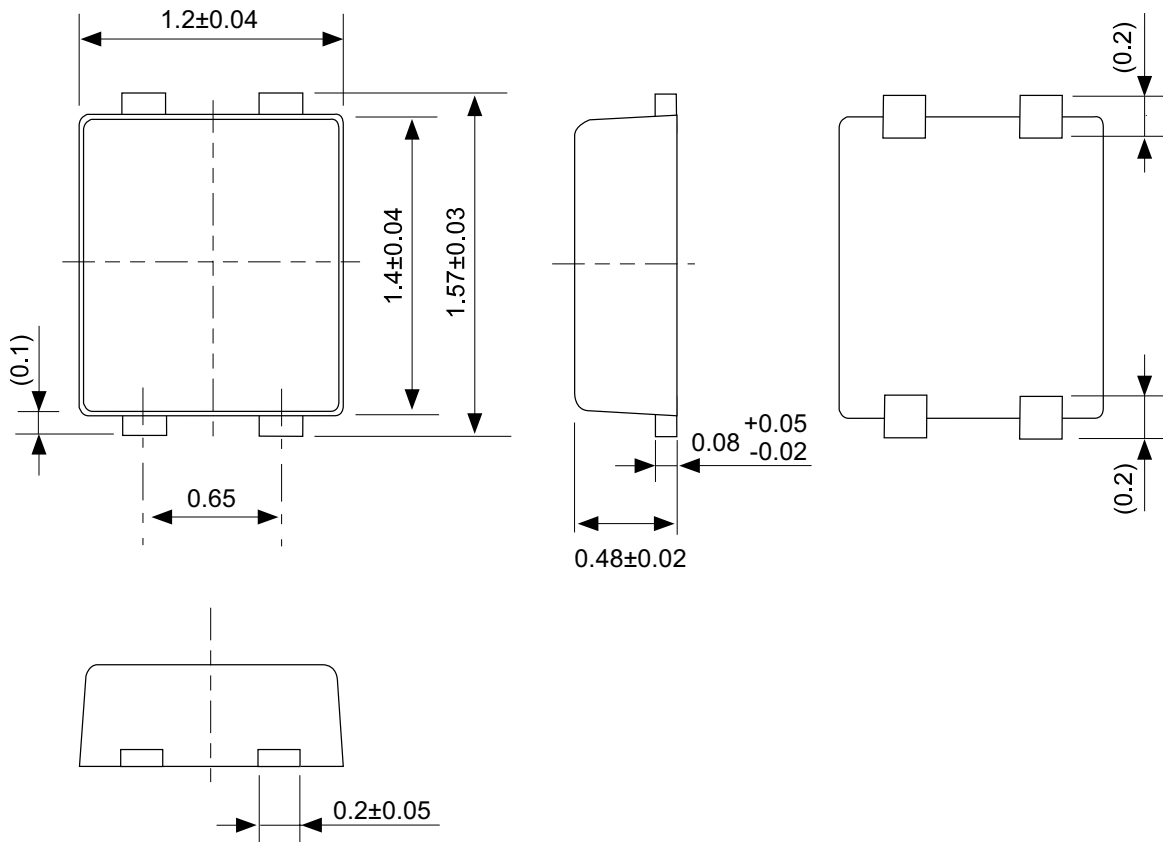

No. PF004-A-P-SD-3.0

TITLE	SNT-4A-A-PKG Dimensions
No.	PF004-A-P-SD-3.0
SCALE	
UNIT	mm
Seiko Instruments Inc.	

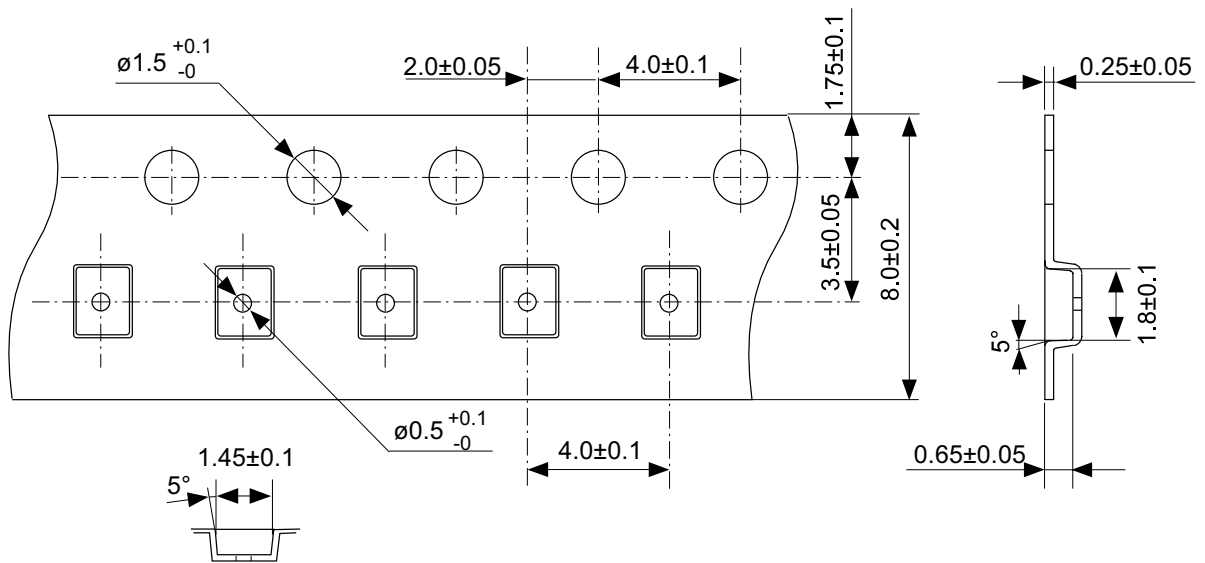

TF type

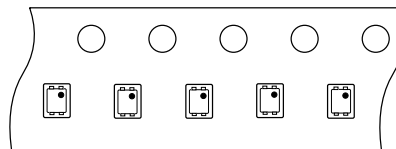
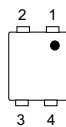

Feed direction

No. PF004-A-C-SD-1.0

TITLE	SNT-4A-A-Carrier Tape
No.	PF004-A-C-SD-1.0
SCALE	
UNIT	mm
Seiko Instruments Inc.	



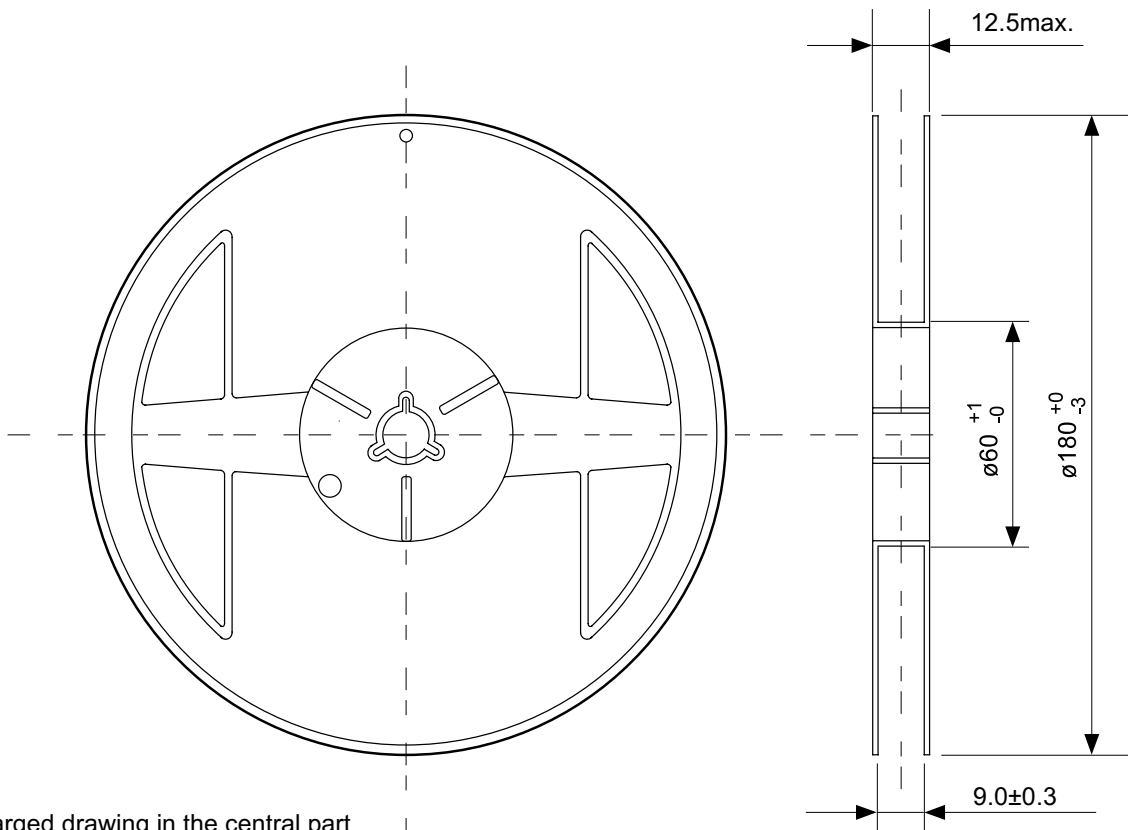

Enlarged drawing in the central part

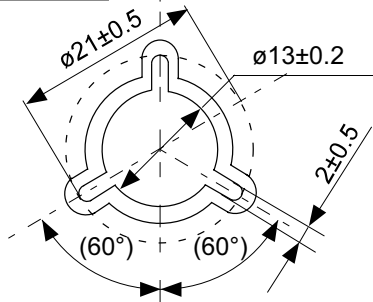

No. PF004-A-R-SD-1.0

TITLE	SNT-4A-A-Reel		
No.	PF004-A-R-SD-1.0		
SCALE		QTY.	5,000
UNIT	mm		
Seiko Instruments Inc.			

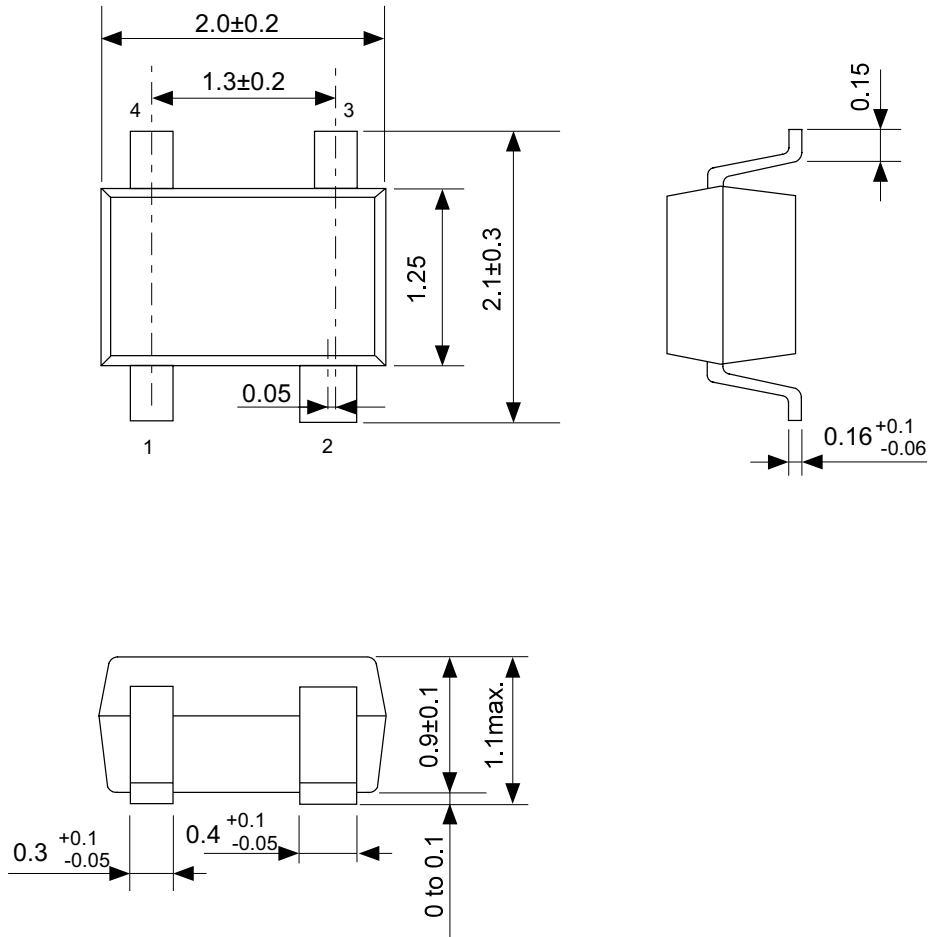

No. NP004-A-P-SD-1.1

TITLE	SC82AB-A-PKG Dimensions
No.	NP004-A-P-SD-1.1
SCALE	
UNIT	mm
Seiko Instruments Inc.	

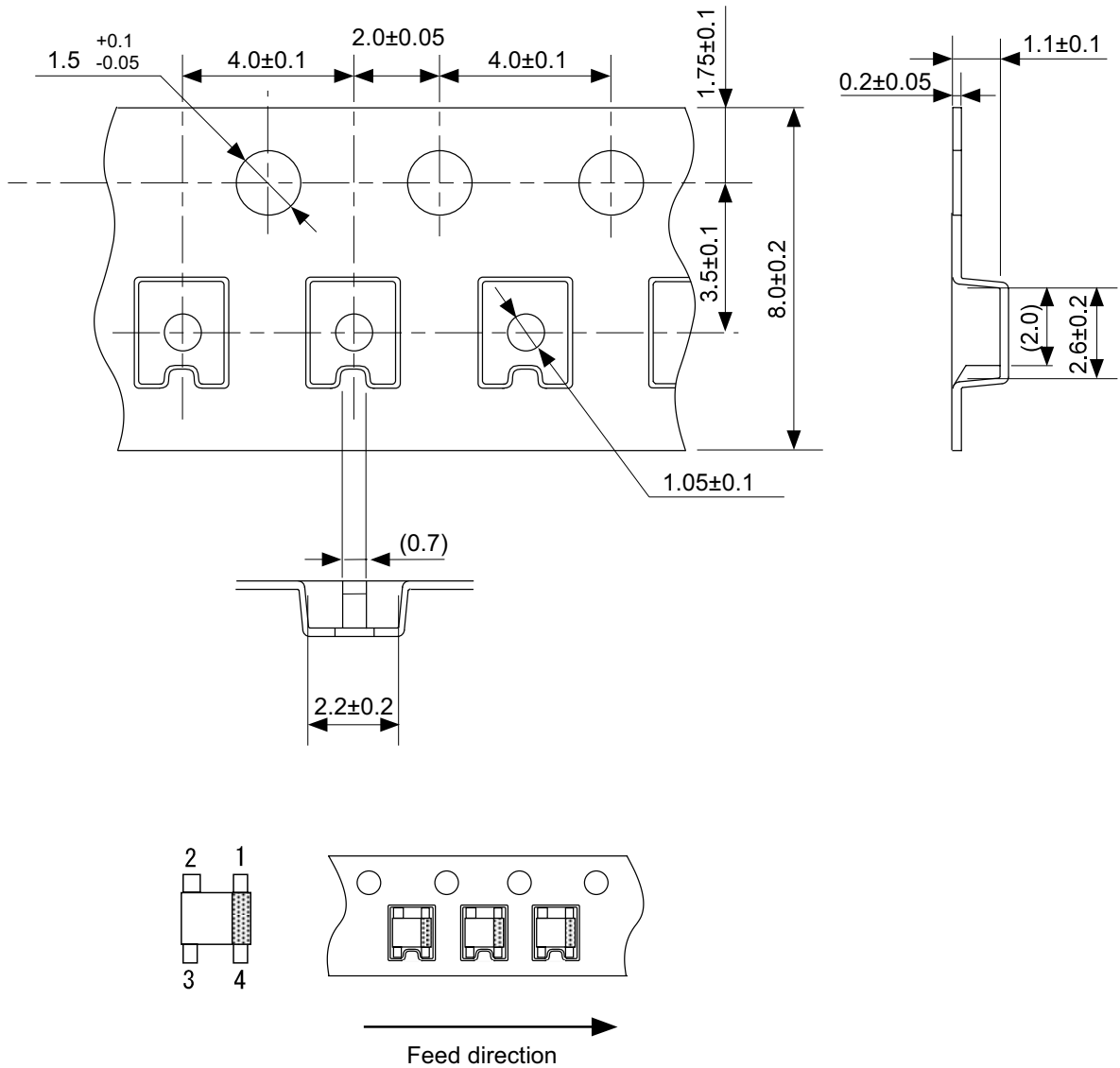

No. NP004-A-C-SD-2.1

TITLE	SC82AB-A-Carrier Tape
No.	NP004-A-C-SD-2.1
SCALE	
UNIT	mm
Seiko Instruments Inc.	

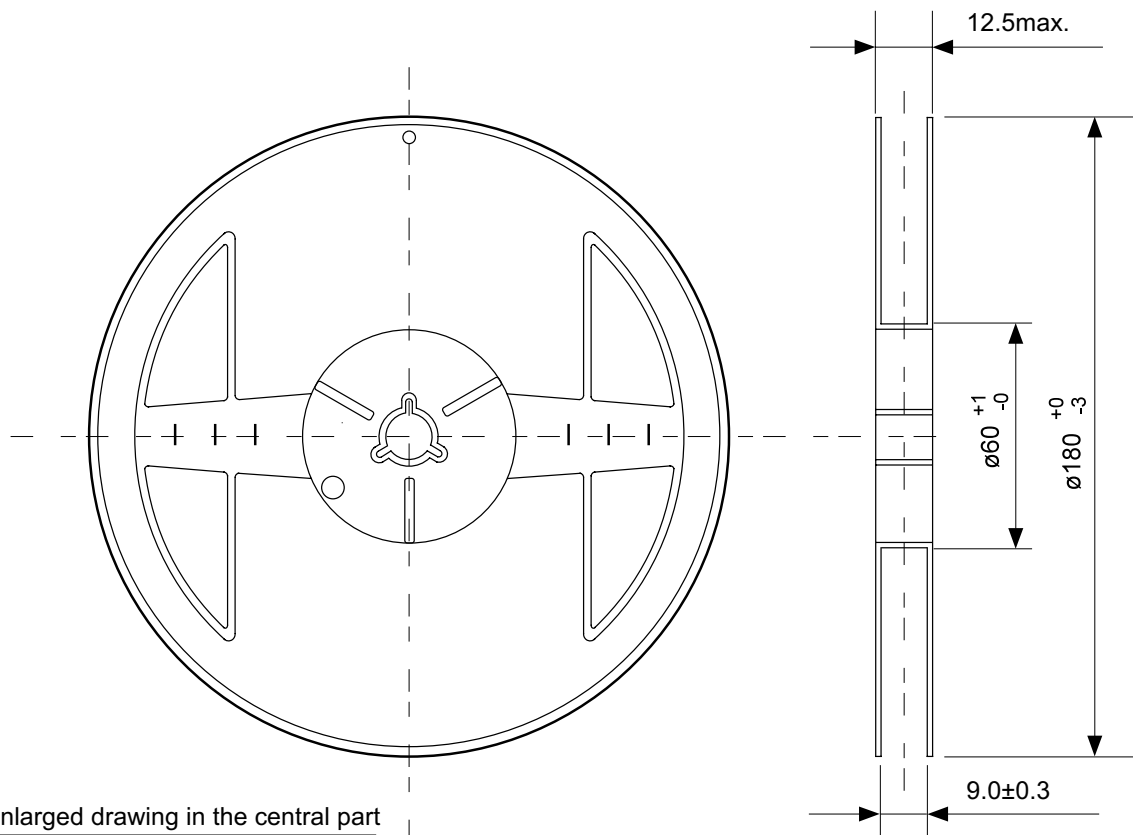

Enlarged drawing in the central part

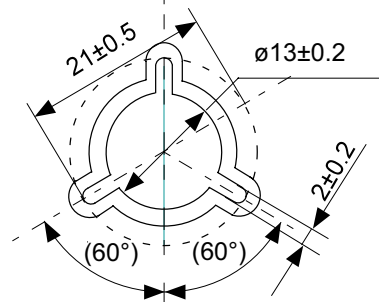

No. NP004-A-R-SD-1.1

TITLE	SC82AB-A-Reel		
No.	NP004-A-R-SD-1.1		
SCALE		QTY.	3,000
UNIT	mm		
Seiko Instruments Inc.			

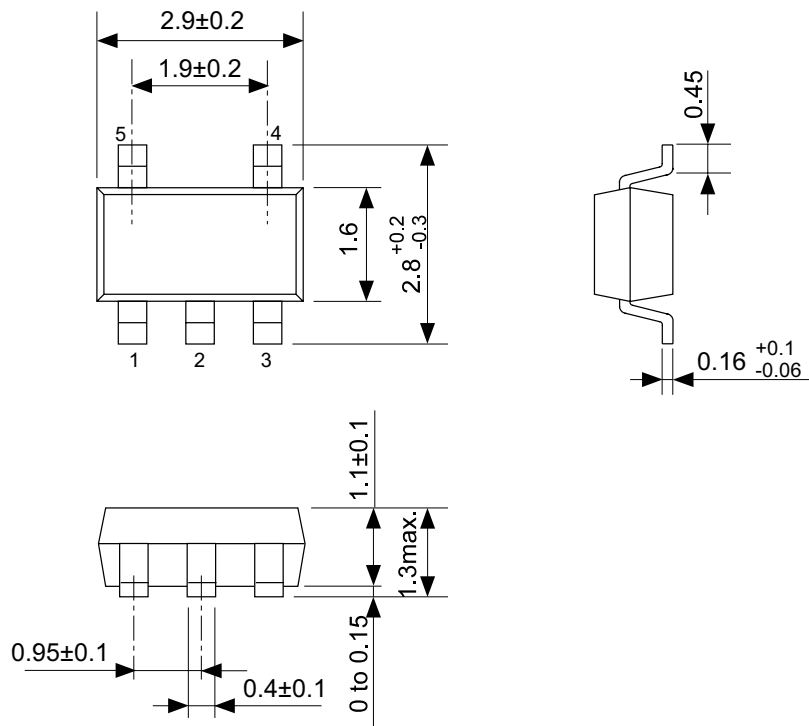

No. MP005-A-P-SD-1.2

TITLE	SOT235-A-PKG Dimensions
No.	MP005-A-P-SD-1.2
SCALE	
UNIT	mm
Seiko Instruments Inc.	

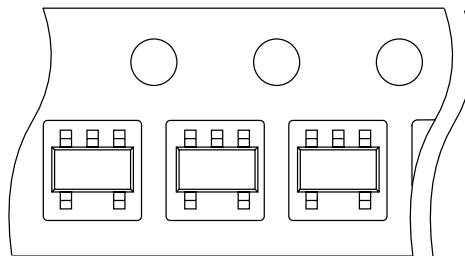
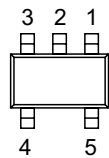
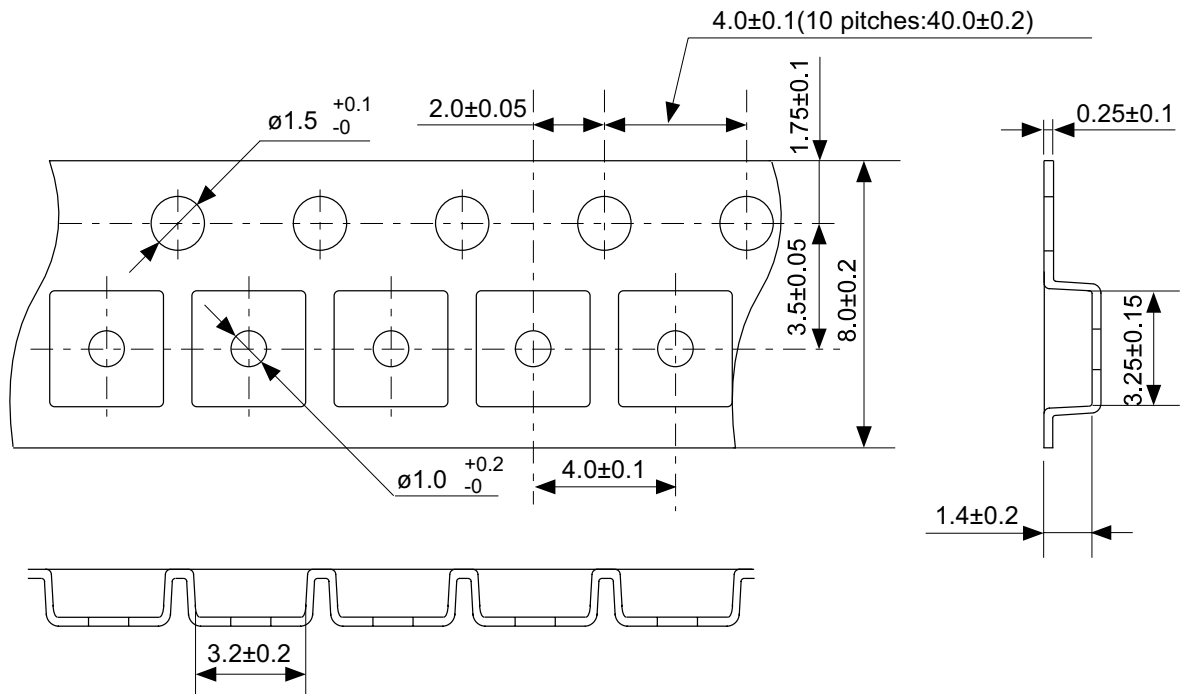

→  
Feed direction

No. MP005-A-C-SD-2.1

TITLE	SOT235-A-Carrier Tape
No.	MP005-A-C-SD-2.1
SCALE	
UNIT	mm
Seiko Instruments Inc.	

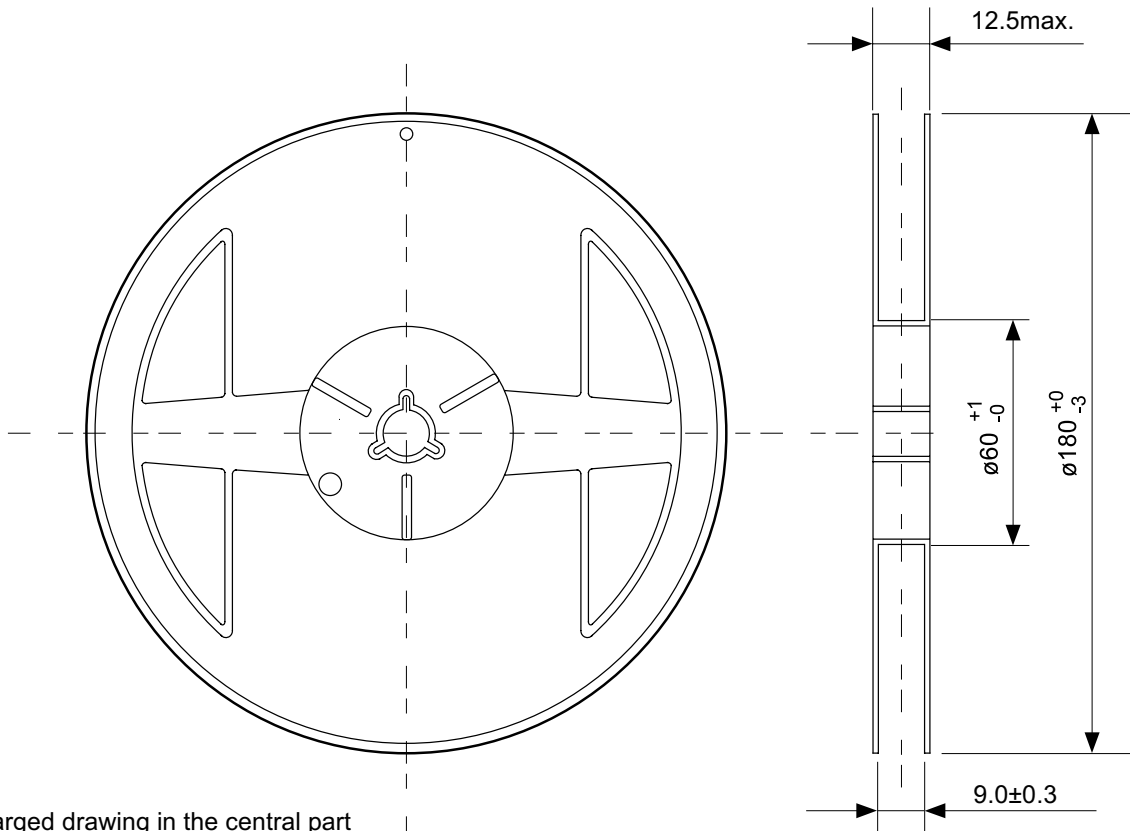

Enlarged drawing in the central part

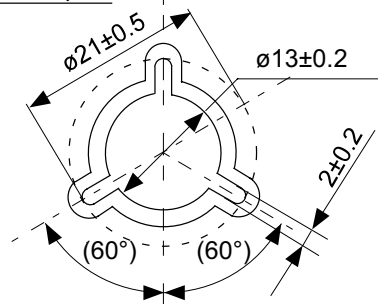

No. MP005-A-R-SD-1.1

TITLE	SOT235-A-Reel		
No.	MP005-A-R-SD-1.1		
SCALE		QTY.	3,000
UNIT	mm		
Seiko Instruments Inc.			

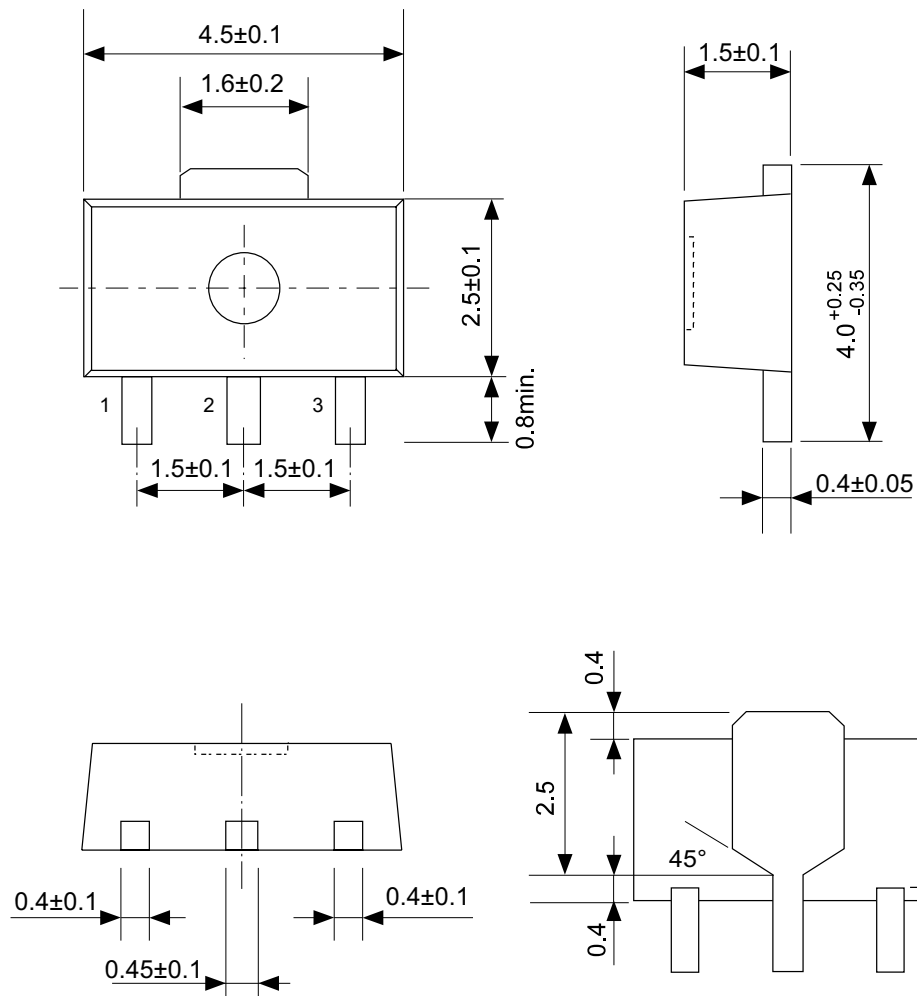

No. UP003-A-P-SD-1.1

TITLE	SOT893-A-PKG Dimensions
No.	UP003-A-P-SD-1.1
SCALE	
UNIT	mm
Seiko Instruments Inc.	



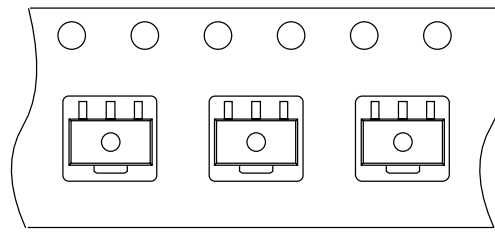
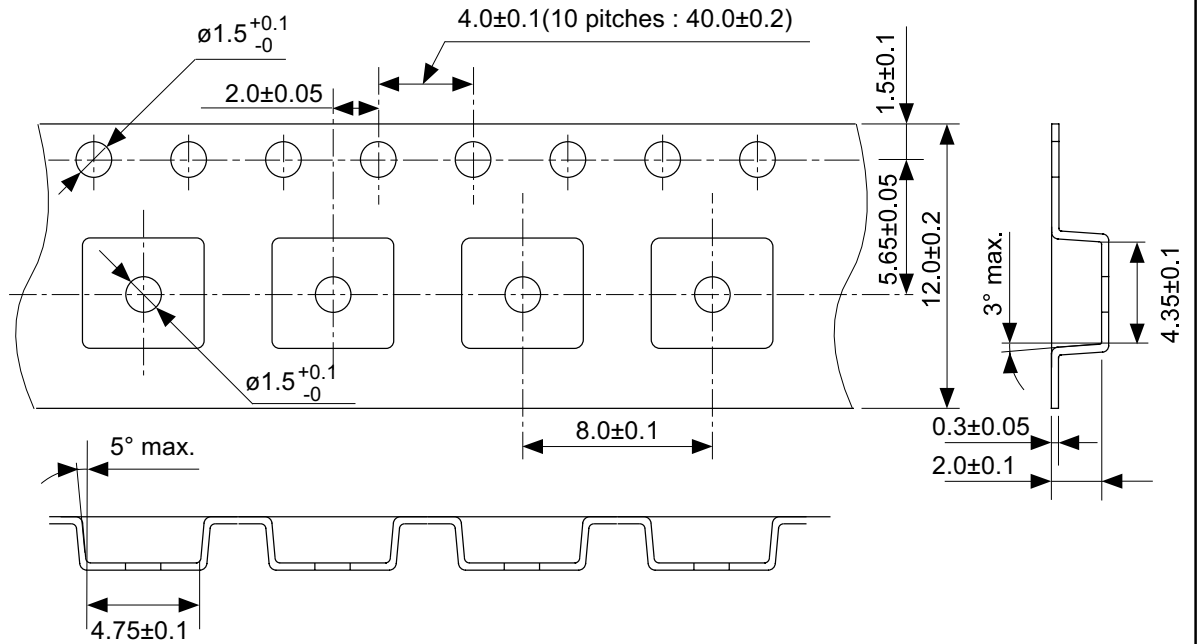

Feed direction →

No. UP003-A-C-SD-1.1

TITLE	SOT893-A-Carrier Tape
No.	UP003-A-C-SD-1.1
SCALE	
UNIT	mm

Seiko Instruments Inc.

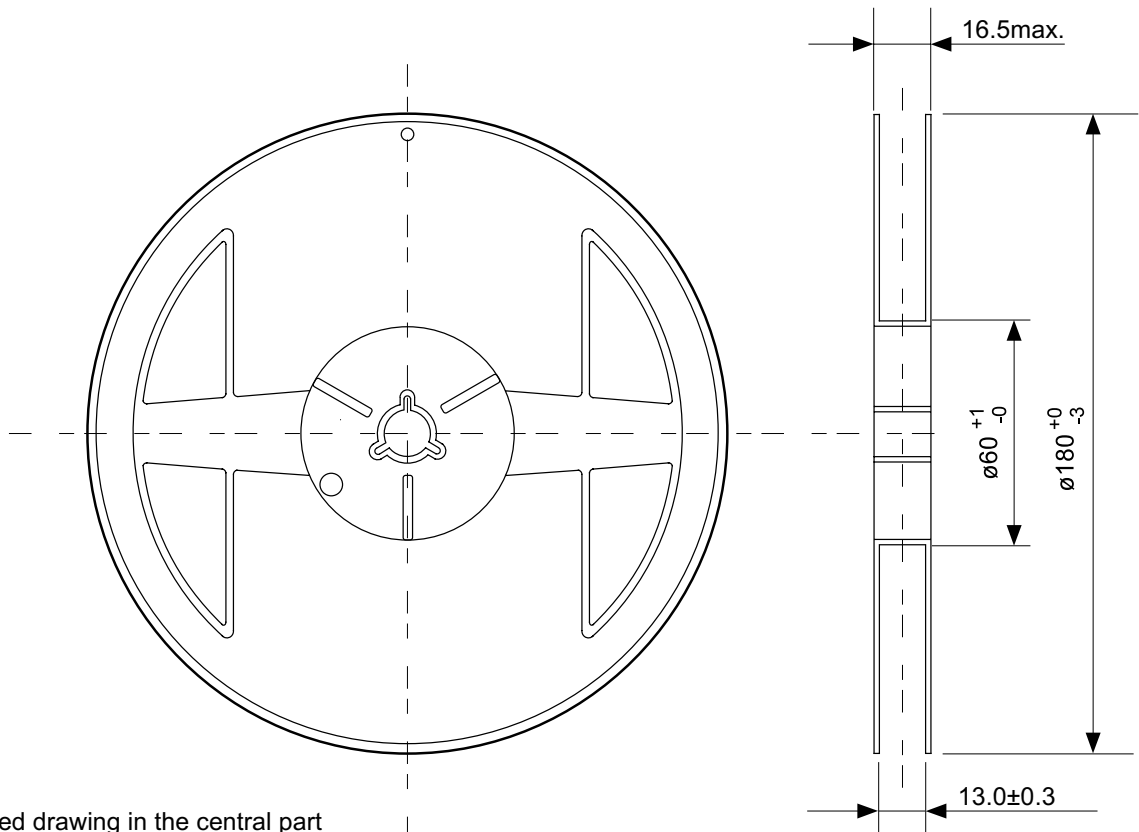

Enlarged drawing in the central part

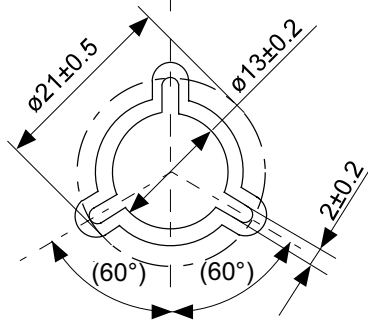

No. UP003-A-R-SD-1.1

TITLE	SOT893-A-Reel		
No.	UP003-A-R-SD-1.1		
SCALE		QTY.	1,000
UNIT	mm		
Seiko Instruments Inc.			

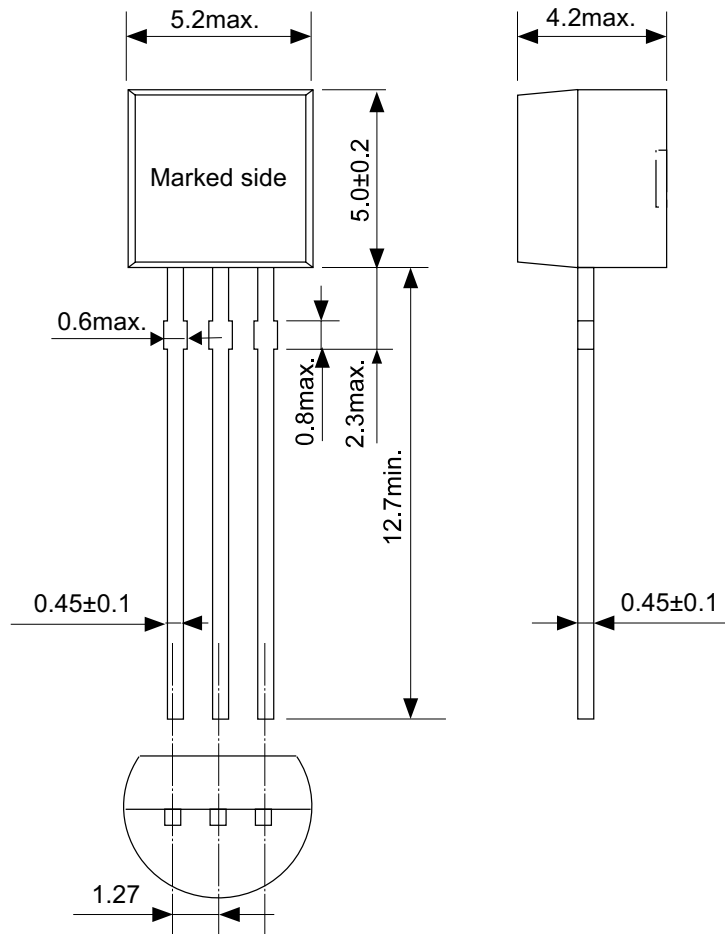

No. YS003-B-P-SD-1.1

TITLE	TO92-B-PKG Dimensions
No.	YS003-B-P-SD-1.1
SCALE	
UNIT	mm

Seiko Instruments Inc.

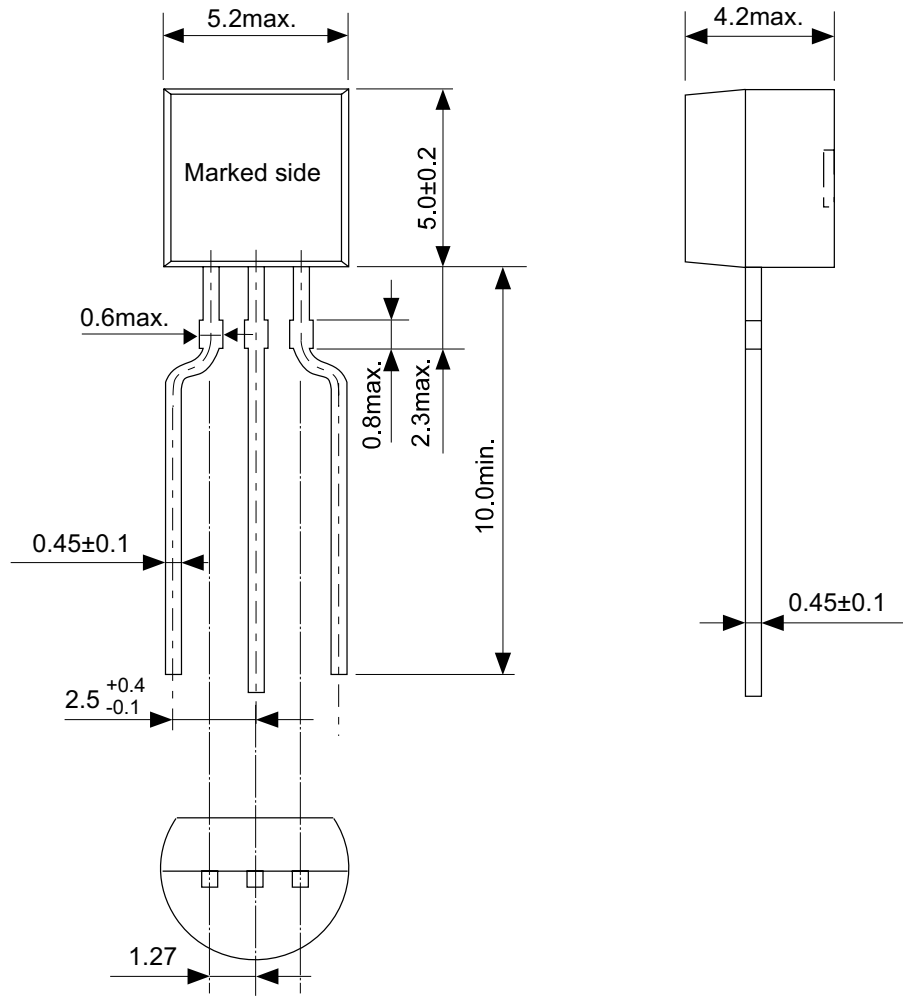

No. YF003-A-P-SD-1.1

TITLE	TO92-A-PKG Dimensions
No.	YF003-A-P-SD-1.1
SCALE	
UNIT	mm
Seiko Instruments Inc.	



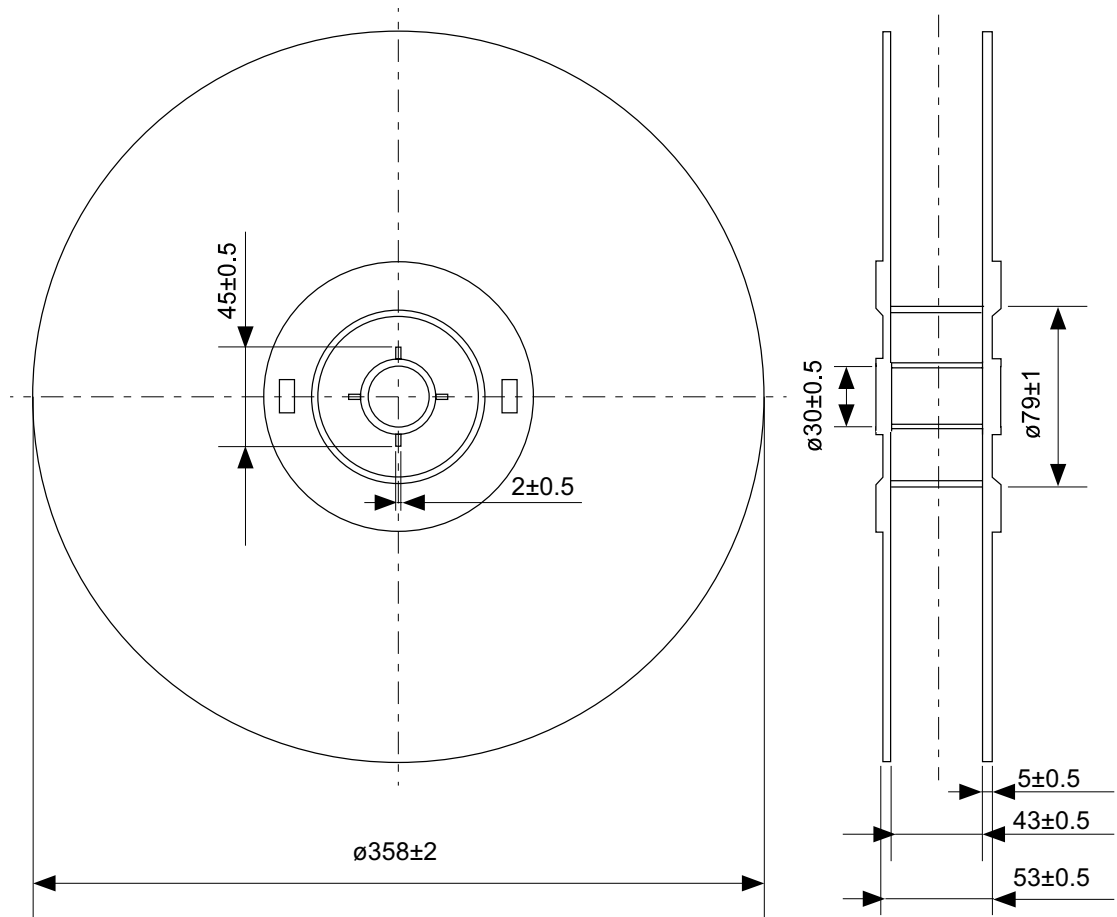

No. YF003-A-R-SD-2.1

TITLE	TO92-A-Reel		
No.	YF003-A-R-SD-2.1		
SCALE		QTY.	2,000
UNIT	mm		
Seiko Instruments Inc.			

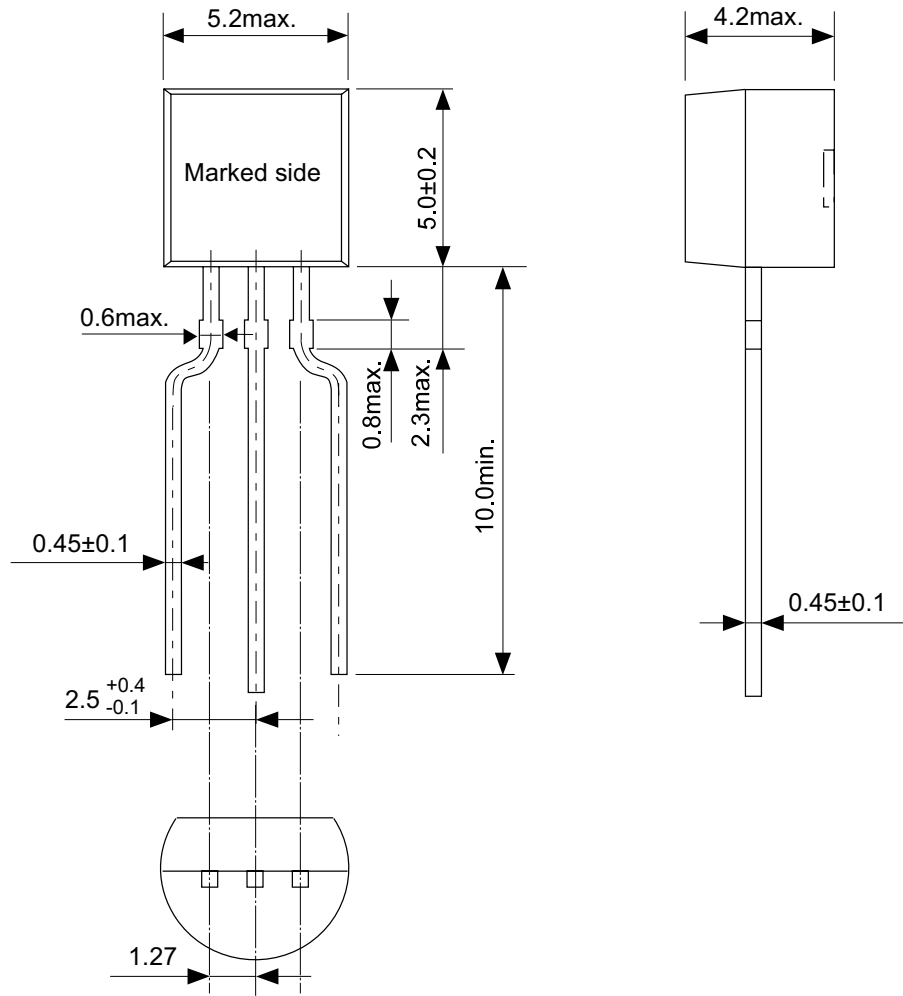

No. YF003-A-P-SD-1.1

TITLE	TO92-A-PKG Dimensions
No.	YF003-A-P-SD-1.1
SCALE	
UNIT	mm
Seiko Instruments Inc.	

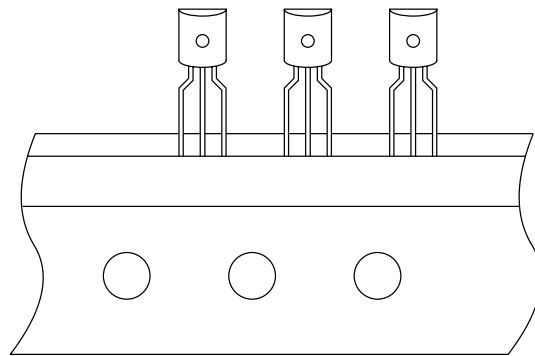
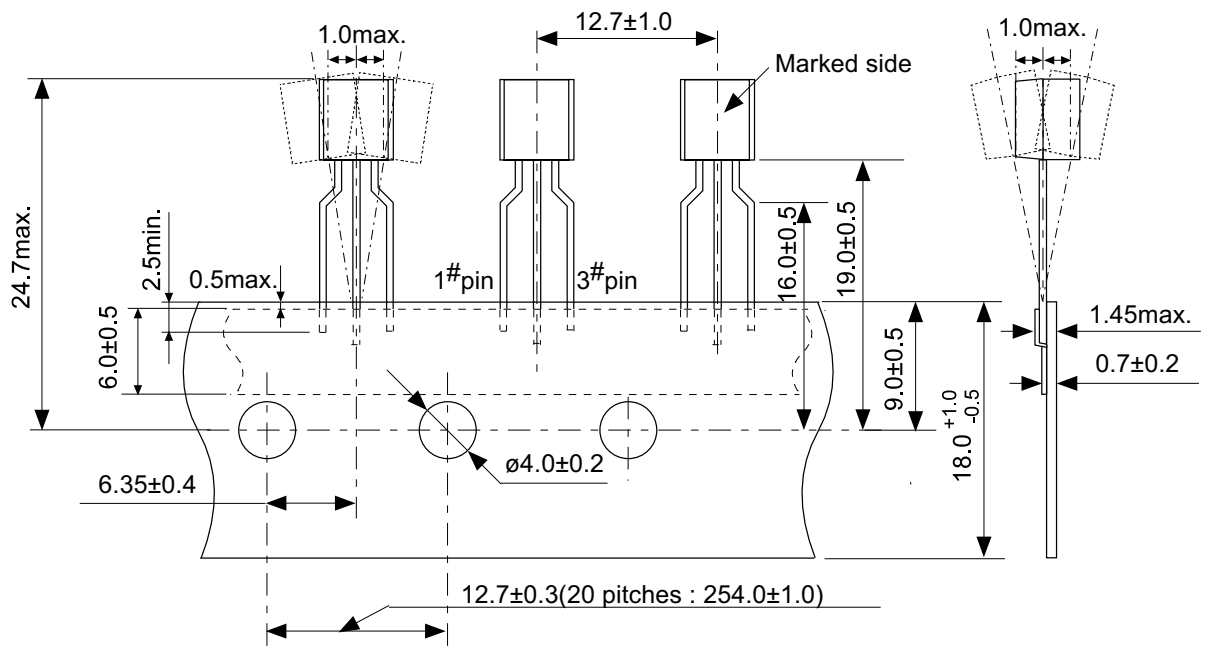

No. YZ003-C-C-SD-3.1

TITLE	TO92-C-Radial Tape
No.	YZ003-C-C-SD-3.1
SCALE	
UNIT	mm
Seiko Instruments Inc.	



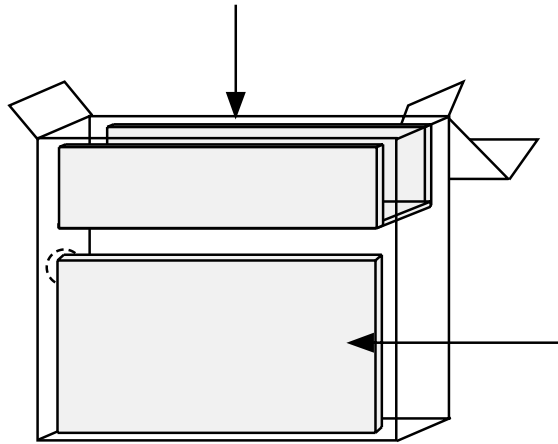
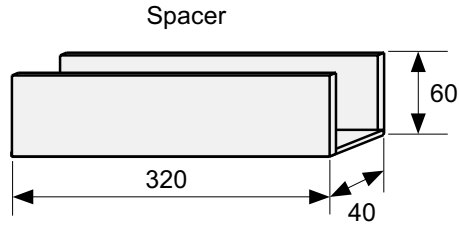

Side spacer placed in front side

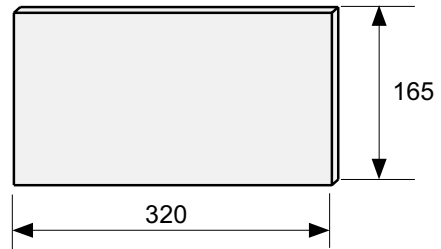

Space more than 4 strokes

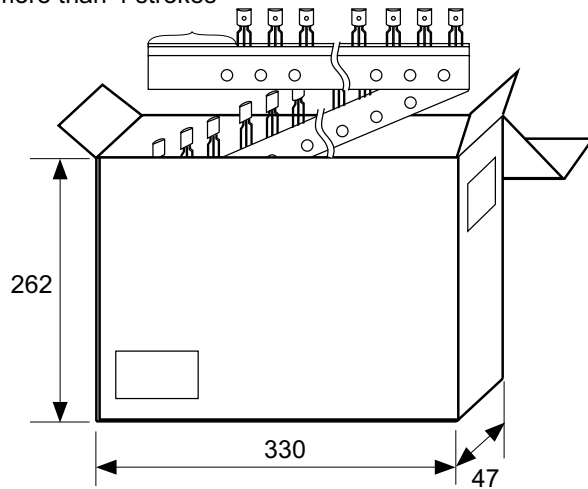

No. YZ003-C-Z-SD-2.1

TITLE	TO92-C-Ammo Packing		
No.	YZ003-C-Z-SD-2.1		
SCALE		QTY.	2,500
UNIT	mm		
Seiko Instruments Inc.			

- The information described herein is subject to change without notice.
- Seiko Instruments Inc. is not responsible for any problems caused by circuits or diagrams described herein whose related industrial properties, patents, or other rights belong to third parties. The application circuit examples explain typical applications of the products, and do not guarantee the success of any specific mass-production design.
- When the products described herein are regulated products subject to the Wassenaar Arrangement or other agreements, they may not be exported without authorization from the appropriate governmental authority.
- Use of the information described herein for other purposes and/or reproduction or copying without the express permission of Seiko Instruments Inc. is strictly prohibited.
- The products described herein cannot be used as part of any device or equipment affecting the human body, such as exercise equipment, medical equipment, security systems, gas equipment, or any apparatus installed in airplanes and other vehicles, without prior written permission of Seiko Instruments Inc.
- Although Seiko Instruments Inc. exerts the greatest possible effort to ensure high quality and reliability, the failure or malfunction of semiconductor products may occur. The user of these products should therefore give thorough consideration to safety design, including redundancy, fire-prevention measures, and malfunction prevention, to prevent any accidents, fires, or community damage that may ensue.