

DATA SHEET

Part No.	AN77033SP
Package Code No.	SP-3SUA

Contents

■ Overview	3
■ Features	3
■ Applications	3
■ Package	3
■ Type	3
■ Block Diagram	4
■ Pin Descriptions	5
■ Absolute Maximum Ratings	6
■ Operating Supply Voltage Range	6
■ Electrical Characteristics	7
■ Electrical Characteristics (Reference values for design)	8
■ Technical Data	9
■ Usage Notes	10

AN77033SP

3-pin, positive output, low dropout voltage regulator (1.2 A type)

■ Overview

AN77xxSP series is suitable for low-voltage, battery driven equipment, and home appliances and industrial equipment with great fluctuation of the supply voltage.

The output voltage ranges : 3.3 V, 3.5 V, 5 V, 6 V, 7 V, 8 V, 9 V, 10 V, 12 V, and 15 V

The AN77033SP is the 3.3 V output voltage type in these series.

■ Features

- Minimum I/O voltage difference: 0.5 V typ.
- On-chip overcurrent limiter
- On-chip thermal protection circuit
- On-chip inrush current protection circuit at the time of input voltage start-up
- On-chip input short-circuit protection circuit

(When the input pin is short-circuited to the ground, the circuit between pins 1 and 3 is shut down to prevent current flow.)

■ Applications

- Power supply equipment.

■ Package

- 3 pin Plastic Surface Mount Power Package (SP Type).

■ Type

- Silicon monolithic bipolar IC.

■ Block Diagram

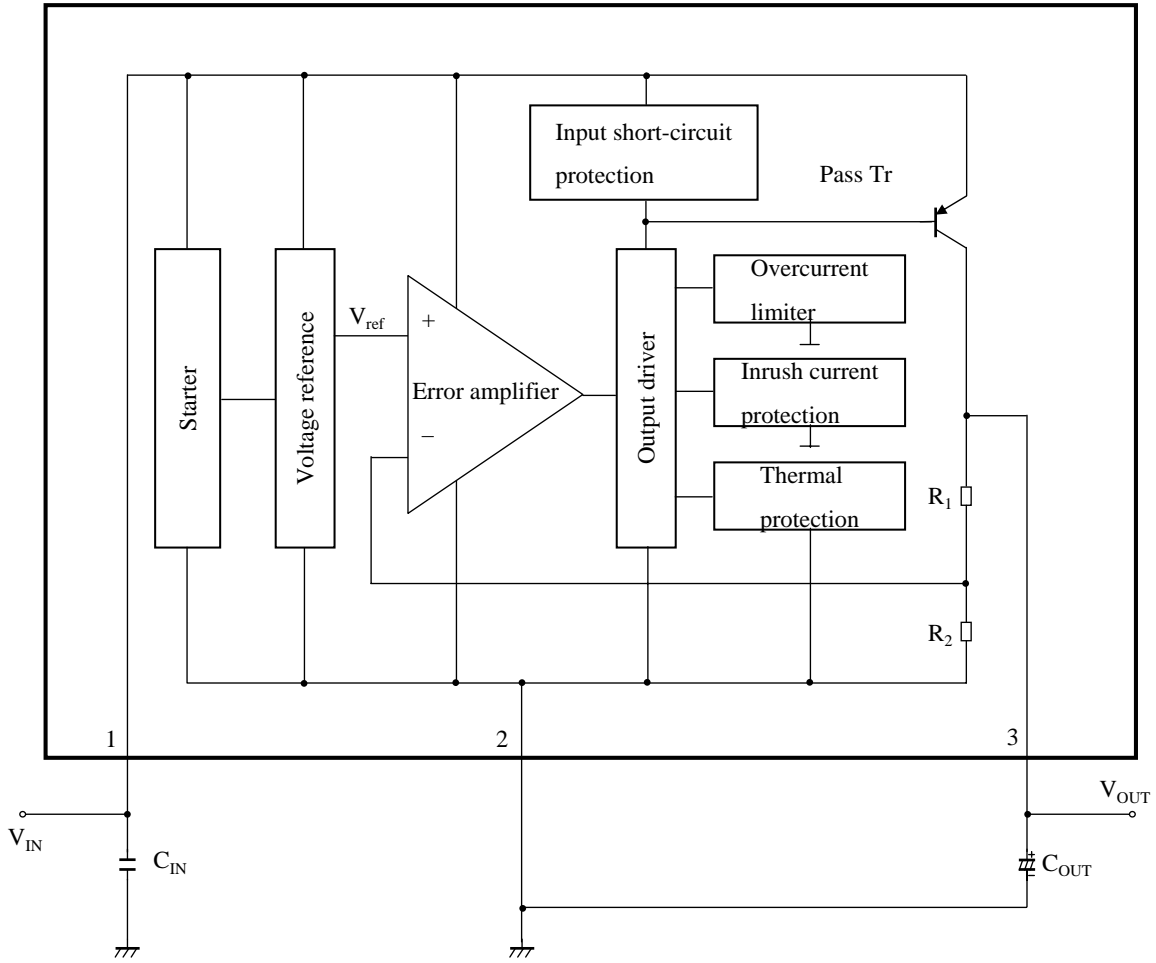

C_{IN} : 0.33 μ F
 C_{OUT} : 33 μ F

■ Pin Descriptions

Pin No.	Pin name	Type	Description
1	Input	Input	Input pin
2	Common	GND	Ground pin
3	Output	Output	Output pin

■ Absolute Maximum Ratings

A No.	Parameter	Symbol	Rating	Unit	Note
1	Supply voltage	V_{CC}	30	V	*1
2	Supply current	I_{CC}	2.4	A	*2
3	Power dissipation	P_D	364.9	mW	*3
4	Operating ambient temperature	T_{opr}	-30 to +85	°C	*4
5	Storage temperature	T_{stg}	-55 to +150	°C	*4

Note) 1. This IC is not applicable to automotive electronic parts.

2. *1: The values under the condition not exceeding the above absolute maximum ratings and the power dissipation.

At the application of $V_{CC} = 30$ V, the overvoltage protection may be operated by the ASO protection circuit, leading to the output shut down.

*2: The current value does not exceed this criterion because of the on-chip current limiter.

*3: The internal circuit shuts off the output when $T_j \geq 150^\circ\text{C}$ (designed value).

The power dissipation shown is the value at $T_a = 85^\circ\text{C}$ for the independent (unmounted) IC package without a heat sink.

When using this IC, refer to the $\bullet P_D - T_a$ diagram in the ■ Technical Data and use under the condition not exceeding the allowable value.

*4: Except for the power dissipation, operating ambient temperature, and storage temperature, all ratings are for $T_a = 25^\circ\text{C}$

■ Operating supply voltage range

Parameter	Symbol	Range	Unit	Note
Supply voltage range	V_{CC}	4.3 to 14	V	—

Note) The values under the condition not exceeding the above absolute maximum ratings and the power dissipation.

■ Electrical Characteristics

Note) Unless otherwise specified, $T_a = 25^\circ\text{C} \pm 2^\circ\text{C}$

B No.	Parameter	Symbol	Conditions	Limits			Unit	Note
				Min	Typ	Max		
1	Output voltage	V_{OUT}	$V_{\text{IN}} = 4.3 \text{ V}$, $T_j = 25^\circ\text{C}$ $I_{\text{OUT}} = 500 \text{ mA}$	3.20	3.30	3.40	V	—
2	Line regulation	REG_{IN}	$V_{\text{IN}} = 4.3 \text{ V to } 14 \text{ V}$ $I_{\text{OUT}} = 500 \text{ mA}$, $T_j = 25^\circ\text{C}$	—	3	35	mV	—
3	Load regulation	REG_{LOA}	$V_{\text{IN}} = 4.3 \text{ V}$, $T_j = 25^\circ\text{C}$ $I_{\text{OUT}} = 0 \text{ mA to } 1\,200 \text{ mA}$,	—	15	70	mV	—
4	Input dependency of bias current	$\Delta I_{\text{bias(IN)}}$	$V_{\text{IN}} = 4.3 \text{ V to } 14 \text{ V}$, $I_{\text{OUT}} = 500 \text{ mA}$, $T_j = 25^\circ\text{C}$	—	1	10	mA	—
5	Load dependency of bias current	$\Delta I_{\text{bias(LOA)}}$	$V_{\text{IN}} = 4.3 \text{ V}$, $I_{\text{OUT}} = 0 \text{ mA to } 1\,200 \text{ mA}$, $T_j = 25^\circ\text{C}$	—	10	50	mA	—
6	Bias current at no load	I_{bias}	$V_{\text{IN}} = 4.3 \text{ V}$, $I_{\text{OUT}} = 0 \text{ mA}$	—	2.6	5.0	mA	—
7	Bias current before the regulation starts	I_{rush}	$V_{\text{IN}} = 2.97 \text{ V}$, $I_{\text{OUT}} = 0 \text{ mA}$	—	3.0	5.0	mA	—
8	Minimum I/O voltage difference 1	$V_{\text{DIF(min)1}}$	$V_{\text{IN}} = 3.75 \text{ V}$, $I_{\text{OUT}} = 500 \text{ mA}$ $T_j = 25^\circ\text{C}$	—	0.4	0.6	V	—
9	Minimum I/O voltage difference 2	$V_{\text{DIF(min)2}}$	$V_{\text{IN}} = 3.75 \text{ V}$, $I_{\text{OUT}} = 1\,200 \text{ mA}$ $T_j = 25^\circ\text{C}$	—	0.5	1.0	V	—
10	Peak output current 1	$I_{\text{O(peak)1}}$	$V_{\text{IN}} = 4.3 \text{ V}$, $T_j = 25^\circ\text{C}$	1.2	1.8	2.4	A	*
11	Ripple rejection ratio	R.R	$V_{\text{IN}} = 4.3 \text{ V to } 8 \text{ V}$, $I_{\text{OUT}} = 100 \text{ mA}$, $f = 120 \text{ Hz}$	54	74	—	dB	—

Note) *: This current exceeds $P_{\text{D(max)}}$ because it is a parameter during abnormal (overcurrent) operation. However, normally, it shall conform to the $\bullet P_{\text{D}} - T_a$ diagram in the ■ Technical Data.

■ Electrical Characteristics (Reference values for design)

Note) Unless otherwise specified, $T_a = 25^\circ\text{C} \pm 2^\circ\text{C}$

The characteristics listed below are reference values for design of the IC and are not guaranteed by inspection.
If a problem does occur related to these characteristics, Matsushita will respond in good faith to user concerns.

B No.	Parameter	Symbol	Conditions	Reference values			Unit	Note
				Min	Typ	Max		
1	Peak output current 2	$I_{O(\text{peak})2}$	$V_{\text{IN}} = 13 \text{ V}, T_j = 25^\circ\text{C}$	—	1.5	—	A	*
2	Peak output current 3	$I_{O(\text{peak})3}$	$V_{\text{IN}} = 18 \text{ V}, T_j = 25^\circ\text{C}$	—	1.0	—	A	*
3	Output short-circuit current	$I_{O(\text{short})}$	$V_{\text{IN}} = 30 \text{ V}, T_j = 25^\circ\text{C}$ The load is shorted.	—	10	—	mA	—
4	Thermal protection operating temperature	$T_{j(\text{TH})}$	$V_{\text{IN}} = 4.3 \text{ V}$	—	150	—	$^\circ\text{C}$	—
5	Output voltage temperature coefficient	a	$V_{\text{IN}} = 4.3 \text{ V}$ $T_j = 25^\circ\text{C}$ to 125°C	—	-40	—	ppm/ $^\circ\text{C}$	—
6	Output noise voltage	Vno	$V_{\text{IN}} = 4.3 \text{ V}, T_j = 25^\circ\text{C}$ $I_{\text{OUT}} = 500 \text{ mA}$ $f = 10 \text{ Hz}$ to 100 kHz	—	58	—	$\mu\text{V}[\text{rms}]$	—

Note) *: This current exceeds $P_{D(\text{max})}$ because it is a parameter during abnormal (overcurrent) operation. However, normally, it shall conform to the $\bullet P_D - T_a$ diagram in the ■ Technical Data.

■ Technical Data

- $P_D - T_a$ diagram

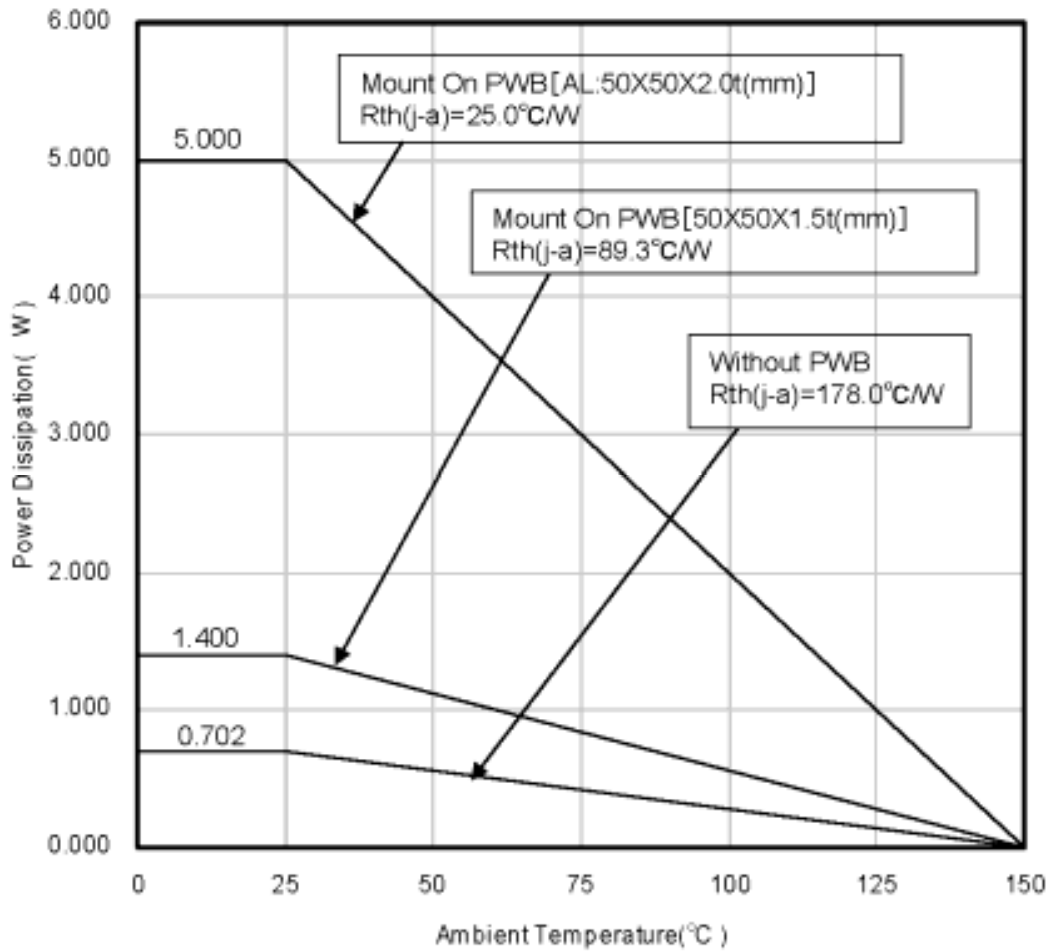

■ Usage Notes

1. Input short-circuit protection circuit

When the DC input pin (pin 1) and the ground pin (pin 2) of our conventional three-pin regulators (AN78xx/SP series, etc.) were short-circuited at normal use conditions in some cases, the voltage of the output pin (pin 3) becomes higher than that of the DC input pin and electrons charged in the output capacitor C_{OUT} flow into the input side, resulting in break of the element.

In those cases, it was necessary for you to connect a general silicon diode as shown in the figure on the right. In the AN77xxSP series, however, it is not necessary to connect the protection diode because these series have a built-in protection circuit to safeguard the element from discharge current.

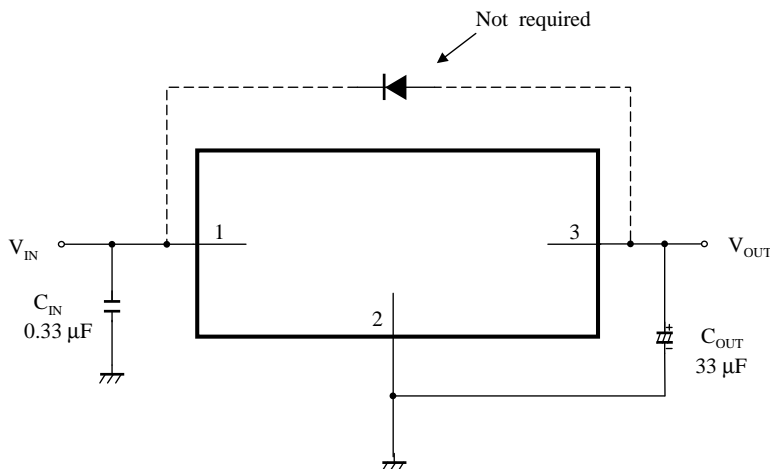

2. Capacitor for external compensation

To maintain the stability, insert a 33 μF capacitor as close to pin 3 and pin 2 as possible. In case of using at low temperature, decrease in capacity of the aluminum electrolytic capacitor and increase of ESR of this capacitor may lead to oscillation.

In the AN77xxSP series, for the output capacitor C_{OUT} , it is recommended to use an aluminum electrolytic capacitor or tantalum capacitor whose equivalent series resistance (ESR) has the temperature characteristic within the recommended area shown on the right.

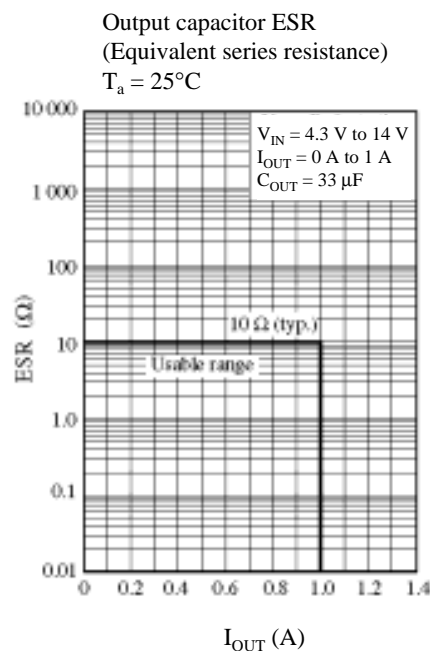
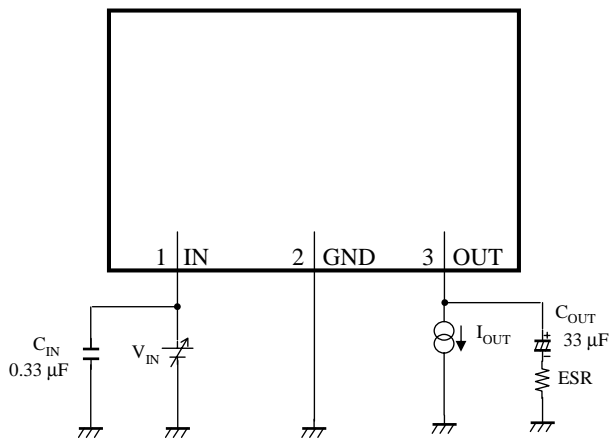

Request for your special attention and precautions in using the technical information and semiconductors described in this book

- (1) If any of the products or technical information described in this book is to be exported or provided to non-residents, the laws and regulations of the exporting country, especially, those with regard to security export control, must be observed.
- (2) The technical information described in this book is intended only to show the main characteristics and application circuit examples of the products, and no license is granted under any intellectual property right or other right owned by our company or any other company. Therefore, no responsibility is assumed by our company as to the infringement upon any such right owned by any other company which may arise as a result of the use of technical information described in this book.
- (3) The products described in this book are intended to be used for standard applications or general electronic equipment (such as office equipment, communications equipment, measuring instruments and household appliances).
Consult our sales staff in advance for information on the following applications:
 - Special applications (such as for airplanes, aerospace, automobiles, traffic control equipment, combustion equipment, life support systems and safety devices) in which exceptional quality and reliability are required, or if the failure or malfunction of the products may directly jeopardize life or harm the human body.
 - Any applications other than the standard applications intended.
- (4) The products and product specifications described in this book are subject to change without notice for modification and/or improvement. At the final stage of your design, purchasing, or use of the products, therefore, ask for the most up-to-date Product Standards in advance to make sure that the latest specifications satisfy your requirements.
- (5) When designing your equipment, comply with the range of absolute maximum rating and the guaranteed operating conditions (operating power supply voltage and operating environment etc.). Especially, please be careful not to exceed the range of absolute maximum rating on the transient state, such as power-on, power-off and mode-switching. Otherwise, we will not be liable for any defect which may arise later in your equipment.
 - Even when the products are used within the guaranteed values, take into the consideration of incidence of break down and failure mode, possible to occur to semiconductor products. Measures on the systems such as redundant design, arresting the spread of fire or preventing glitch are recommended in order to prevent physical injury, fire, social damages, for example, by using the products.
- (6) Comply with the instructions for use in order to prevent breakdown and characteristics change due to external factors (ESD, EOS, thermal stress and mechanical stress) at the time of handling, mounting or at customer's process. When using products for which damp-proof packing is required, satisfy the conditions, such as shelf life and the elapsed time since first opening the packages.
- (7) This book may be not reprinted or reproduced whether wholly or partially, without the prior written permission of Matsushita Electric Industrial Co., Ltd.