

1A Low Dropout Positive Regulator

1.2V, 1.5V, 1.8V, 2.5V, 3.3V, 5.0V and Adjustable outputs

Description

ZLDO1117 is a low dropout positive adjustable or fixed-mode regulator with 1A output current capability.

The ZLDO1117 has a 2% tolerance across the industrial temperature range and is guaranteed to have lower than 1.2V dropout at full load current making it ideal to provide well-regulated outputs of 1.2V to 5.0V with input supply voltages up to 18V.

The ZLDO1117 is ideally suited to provide well-regulated supplies for low voltage IC applications such as high-speed bus termination and low current 3.3V logic supply across the whole industrial temperature range.

Features

- 1.2V Maximum Dropout at Full Load Current
- 2% tolerance over temperature, line and load variations
- Fast Transient Response
- Output Current Limiting
- Built-in Thermal Shutdown
- Good Noise Rejection
- Suitable for use with MLCC capacitors
- -40 to 125°C Junction temperature range
- Available in "Green" Molding Compound (No Br, Sb) with lead free Finish/RoHS Compliant (Note 1)

Pin Assignments

SOT223

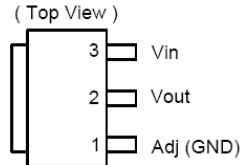

Tab is Vout

TO252

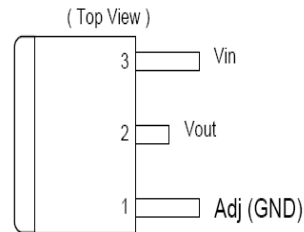

Tab is Vout

Typical Application circuit

1A I/O – 1.8V core regulator

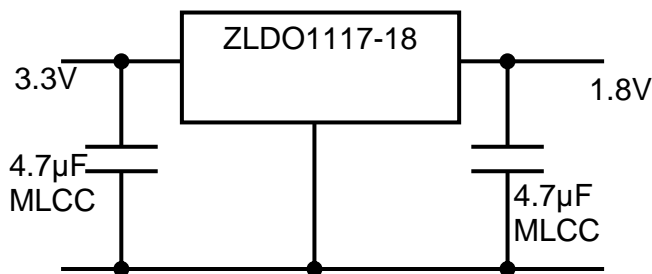

Absolute Maximum Ratings

Parameter	Rating
Input Supply Voltage (V_{IN}) relative to GND	-0.3 to 18V
Junction Temperature (T_J) ³	150°C
Power Dissipation	See SOA curve
Storage Temperature (T_{ST}).....	-65 to +150°C

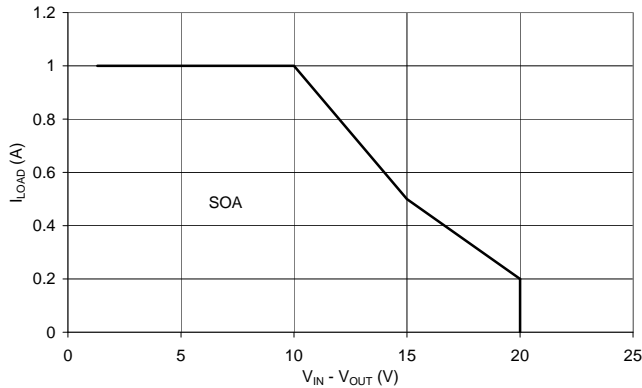

Safe Operation Area (SOA) Curve

These are stress ratings only. Operation outside the absolute maximum ratings may cause device failure. Operation at the absolute maximum rating for extended periods may reduce device reliability.

Semiconductor devices are ESD sensitive and may be damaged by exposure to ESD events. Suitable ESD precautions should be taken when handling and transporting these devices.

Human Body Model: 4kV

Machine Model: 400V

Recommended operating conditions

Parameter	Min	Max	Unit
V_{IN} Input voltage	2.7 ⁶	18	V
I_O Output current	0.01	1	A
T_J Operating Junction Temperature Range	-40	125	°C

Package Thermal Data

Thermal Resistance	Package		Unit
Junction-to-Ambient, θ_{JA}	SOT223-3L ⁴	107	°C/W
	TO252-3L ⁵	73	
Junction-to-Case, θ_{JC}	SOT223-3L ⁴	16	°C/W
	TO252-3L ⁵	12	

Notes: 3. ZLDO1117 contains an internal thermal limiting circuit that is designed to protect the regulator in the event that the maximum junction temperature exceeded. When activated, typically at 150°C, the regulator Output switches off and then back on as the die cools.

- 4. Test condition for SOT223-3L: $T_A = 27^\circ\text{C}$, no air flow, device mounted on 2"X2" polyimide PCB, 2 oz copper, 5.6mmX5.6mm pad.
- 5. Test condition for TO252-3L: $T_A = 27^\circ\text{C}$, no air flow, device mounted on 2"X2" polyimide PCB, 1 oz copper, 2cmX2cm pad.
- 6. Ensures correct operation without entering dropout. Device will continue to operate below this minimum input voltage under dropout conditions.

Electrical Characteristics (Under Operating Conditions)

Parameter	Conditions	T _A	Min	Typ.	Max	Unit	
Reference Voltage	ZLDO1117-ADJ (V _{IN} -V _{OUT}) = 2V, I _O = 10mA	25	1.238	1.250	1.263	V	
		FT	1.225		1.275		
Output Voltage	ZLDO1117-1.2 I _O = 10mA, V _{IN} = 3.2V 0 < I _O < 1A, 2.6V < V _{IN} < 12V	25	1.188	1.200	1.212	V	
		FT	1.176		1.224		
	ZLDO1117-1.5 I _O = 10mA, V _{IN} = 3.5V 0 < I _O < 1A, 2.9V < V _{IN} < 12V	25	1.485	1.500	1.515	V	
		FT	1.470		1.530		
	ZLDO1117-1.8 I _O = 10mA, V _{IN} = 3.8V 0 < I _O < 1A, 3.2V < V _{IN} < 12V	25	1.782	1.800	1.818	V	
		FT	1.764		1.836		
	ZLDO1117-2.5 I _O = 10mA, V _{IN} = 4.5V 0 < I _O < 1A, 3.9V < V _{IN} < 12V	25	2.475	2.500	2.525	V	
		FT	2.450		2.550		
	ZLDO1117-3.3 I _O = 10mA, V _{IN} = 5.3V 0 < I _O < 1A, 4.7V < V _{IN} < 12V	25	3.267	3.300	3.333	V	
		FT	3.235		3.365		
	ZLDO1117-5.0 I _O = 10mA, V _{IN} = 7V 0 < I _O < 1A, 6.4V < V _{IN} < 12V	25	4.95	5.000	5.05	V	
		FT	4.900		5.100		
Line Regulation	ZLDO1117-ADJ I _O = 10mA, V _{OUT} +1.5V<V _{IN} <12V	25			0.1	%	
		FT			0.2		
ZLDO1117-xx I _O = 0mA, V _{OUT} +1.5V<V _{IN} <12V	25				0.1	%	
	FT				0.2		
Load Regulation	ZLDO1117-ADJ V _{IN} =3.3V, V _{ADJ} =0, 10mA<I _O <1A, (Note 7, 8)	25			0.2	%	
		FT			0.4		
	ZLDO1117-1.2 V _{IN} =2.7V, 10mA < I _O < 1A, (Note 7, 8)	25				0.2	%
		FT				0.4	
	ZLDO1117-1.5 V _{IN} = 3V, 0 < I _O < 1A, (Note 7, 8)	25				3	mV
		FT				6	
	ZLDO1117-1.8 V _{IN} = 3.3V, 0 < I _O < 1A, (Note 7, 8)	25				4	mV
		FT				8	
	ZLDO1117-2.5 V _{IN} = 4V, 0 < I _O < 1A, (Note 7, 8)	25				5	mV
		FT				10	
	ZLDO1117-3.3 V _{IN} = 4.8V, 0 < I _O < 1A, (Note 7, 8)	25				6.6	mV
		FT				13	
ZLDO1117-5.0 V _{IN} = 6.5V, 0 < I _O < 1A, (Note 7, 8)	25				10	mV	
	FT				20		
Dropout Voltage (V _{IN} -V _{OUT})	ZLDO1117-ADJ/1.2/1.5/1.8 /2.5/3.3/5.0 I _O = 1A, ΔV _{OUT} = 1%V _{OUT}	25		1.11	1.2	V	
		0 ~ 125			1.3		
		FT			1.35		
Current Limit	ZLDO1117-ADJ/1.2/1.5/1.8 /2.5/3.3/5.0 (V _{IN} -V _{OUT}) = 5V	25				A	
		FT	1.1				
Minimum Load Current (Note 8)	ZLDO1117-ADJ	-40°C < T _J < 125°C			2	5	mA
Quiescent current	ZLDO1117-xx	V _{IN} < 18V, I _O = 0mA	FT		4	10	mA
GND current	ZLDO1117-xx	V _{IN} = 7V	FT		35	120	μA
Thermal Regulation	30ms pulse		25			0.1	%/W
Ripple Rejection	f = 120Hz, C _{OUT} = 25μF Tantalum, I _{OUT} = 100mA, ZLDO1117-XXX V _{IN} = V _{OUT} +3V		25	60	80		dB
Temperature Stability	I _O = 10mA				0.5		%

Notes: 7. See thermal regulation specifications for changes in output voltage due to heating effects. Line and load regulation are measured at a constant junction temperature by low duty cycle pulse testing. Load regulation is measured at the output lead = 1/18" from the package.

8. Line and load regulation are guaranteed up to the maximum power dissipation of 15W. Power dissipation is determined by the difference between input and output differential and the output current. Guaranteed maximum power dissipation will not be available over the full input/output range.

Typical characteristics

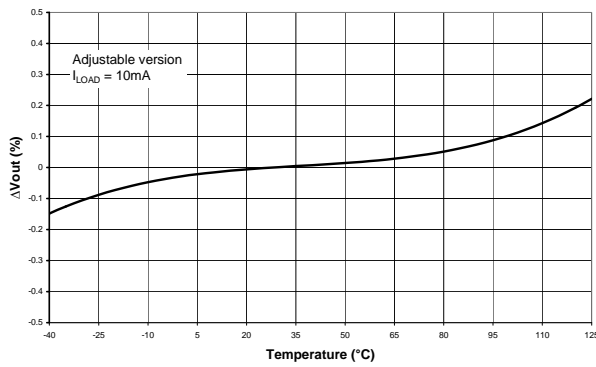

Output voltage variation vs Temperature

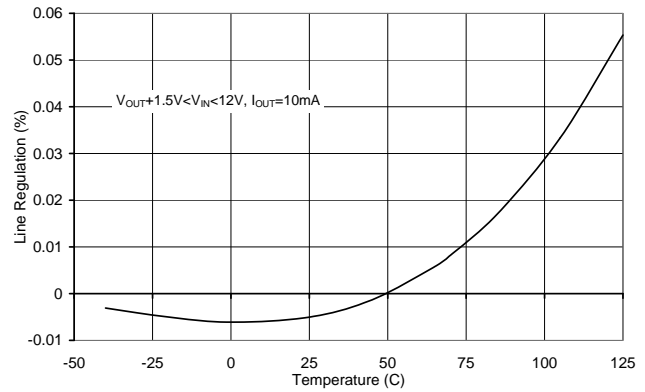

Line regulation vs temperature

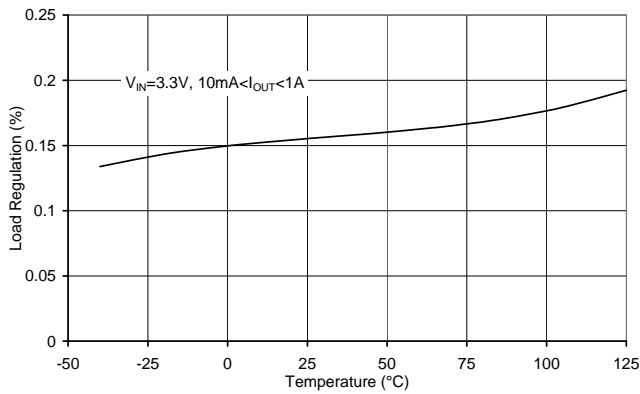

Load regulation vs temperature

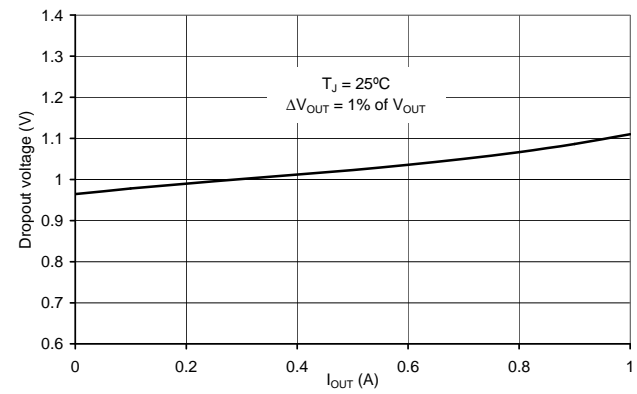

Drop-out voltage vs current

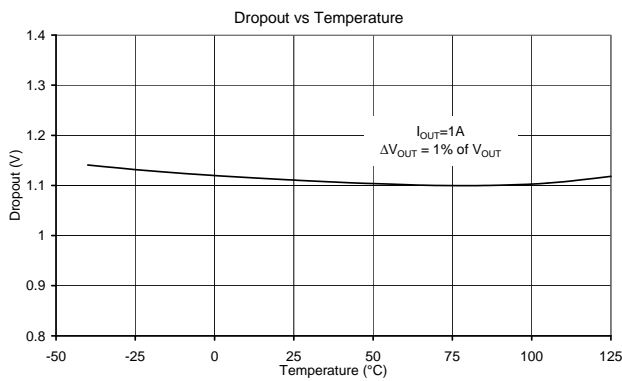

Drop-out voltage vs temperature

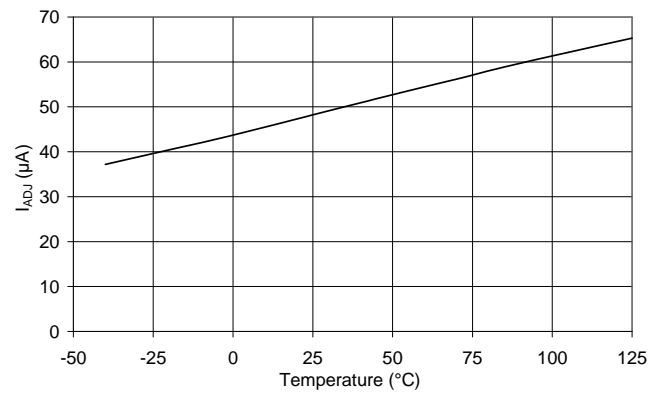

Adjust pin input current

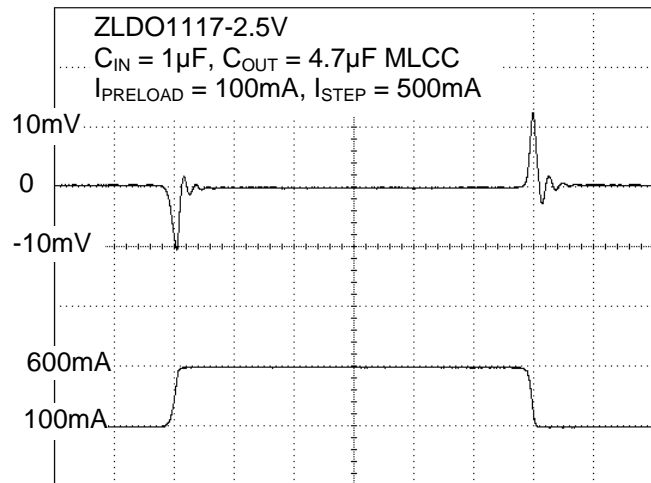
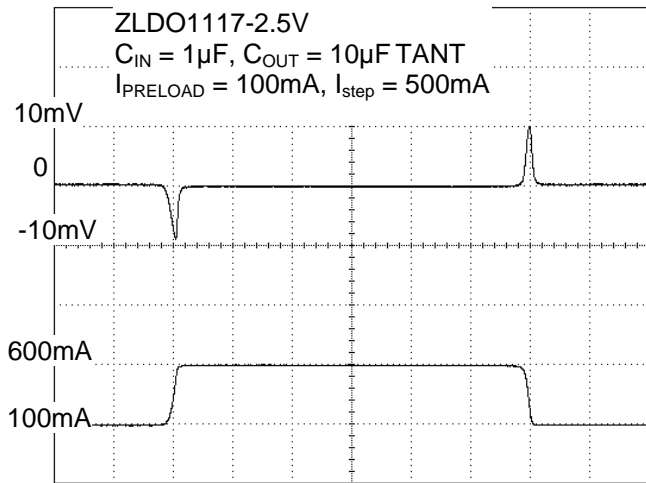

Transient load regulation with 10µF tantalum capacitor

Transient load regulation with 4.7µF MLCC capacitor

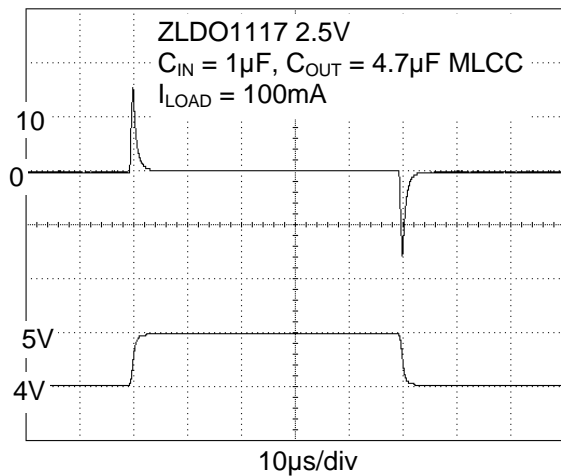

Transient line regulation with 4.7µF MLCC capacitor

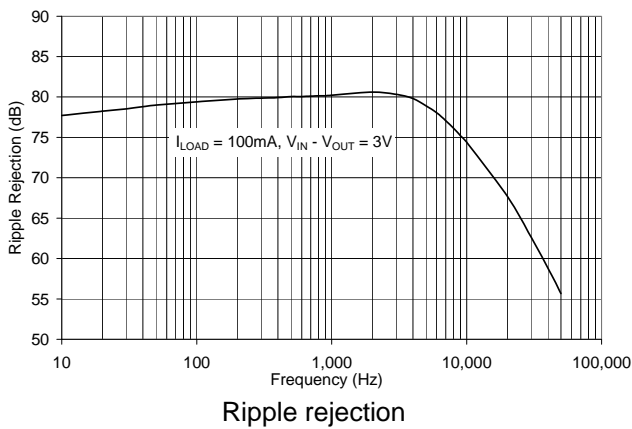

Pin Descriptions

NAME	I/O	Pin #	FUNCTION
Adj (GND)	I	1	A resistor divider from this pin to the V_{OUT} pin and ground sets the output voltage (Ground only for Fixed-Mode).
V_{OUT}	O	2	The output of the regulator. A minimum of 4.7 μ F capacitor ($0.05\Omega \leq ESR \leq 0.5\Omega$) must be connected from this pin to ground to insure stability. For improved ac load response a larger output capacitor is recommended.
V_{IN}	I	3	The input pin of regulator. Typically a large storage capacitor ($0.05\Omega \leq ESR \leq 0.5\Omega$) is connected from this pin to ground to ensure that the input voltage does not sag below the minimum dropout voltage during the load transient response. This pin must always be 1.3V higher than V_{OUT} in order for the device to regulate properly.

Applications information

The ZLDO1117 family of quasi-LDO regulators is easy to use. They are protected against short circuit and thermal overloads. (see block diagram).

Thermal protection circuitry will shut down the regulator should the junction temperature exceed 150°C at the sense point. The ZLDO1117 is pin compatible with similar '1117 regulators and offers extended temperature range and improved regulation specifications.

Operation

The ZLDO1117 develops a 1.25V reference voltage between the output and the adjust terminal (see block diagram). By placing a resistor between these two terminals, a constant current is caused to flow through R1 and down through R2. For fixed output variants Resistors R1 and R2 are internal.

Stability

The ZLDO1117 requires an output capacitor as part of the device frequency compensation. As part of its improved performance over industry standard 1117 the ZLDO1117 is suitable for use with MLCC (Multi Layer Ceramic Chip) capacitors. A minimum of 4.7 μ F ceramic X7R, 4.7 μ F tantalum, or 47 μ F of aluminum electrolytic is required. The ESR of the output capacitor should be less than 0.5 Ω . Surface mount tantalum capacitors, which have very low ESR, are available from several manufacturers. When using MLCC capacitors avoid the use of Y5V dielectrics.

Load Regulation

For improved load regulation the ZLDO1117-ADJ should have the upper feedback resistor, R₁, connected as close as possible to V_{OUT} and the lower resistor, R₂, connected as close as possible to the load GND return. This helps reduce any parasitic resistance in series with the load.

Thermal Considerations

ZLDO1117 series regulators have internal thermal limiting circuitry designed to protect the device during overload conditions. For continuous normal load conditions however, the maximum junction temperature rating of 125°C must not be exceeded.

It is important to give careful consideration to all sources of thermal resistance from junction to ambient. For the SOT-223 and TO-252 packages, which are designed to be surface mounted, additional heat sources mounted near the device must also be considered. Heat sinking is accomplished using the heat spreading capability of the PCB and its copper traces. The θ_{JC} (junction to tab) of the TO-252 and SOT223 are 12°C/W and 16°C/W respectively.

Thermal resistances from tab to ambient can be as low as 30°C/W. The total thermal resistance from junction to ambient can be as low as 42~46°C/W. This requires a reasonable sized PCB with at least one layer of copper to spread the heat across the board and couple it into the surrounding air. Datasheet specifications using 2 oz copper and a 5mmx5mm pad with $T_A=27^\circ\text{C}$, no air flow yielded θ_{JA} (junction to tab) of 73°C/W and 107°C/W for TO-252 and SOT223 respectively.

The thermal resistance for each application will be affected by thermal interactions with other components on the board. Some experimentation will be necessary to determine the actual value.

Ripple Rejection

When using the ZLDO1117 adjustable device the adjust terminal can be bypassed to improve ripple rejection. When the adjust terminal is bypassed the required value of the output capacitor increases.

The device will require an output capacitor of 22 μF tantalum or 150 μF aluminum electrolytic when the adjust pin is bypassed. Normally, capacitor values on the order of 100 μF are used in the output of many regulators to ensure good load transient response with large load current changes. Output capacitance can be increased without limit and larger values of output capacitance further improve stability and transient response.

The curves for Ripple Rejection were generated using an adjustable device with the adjust pin bypassed. These curves will hold true for all values of output voltage. For proper bypassing, and ripple rejection approaching the values shown, the impedance of the adjust pin capacitor, at the ripple frequency, should be $< R1$. $R1$ is normally in the range of 100 Ω to 200 Ω . The size of the required adjust pin capacitor is a function of the input ripple frequency. At 120Hz, with $R1 = 100\Omega$, the adjust pin capacitor should be $>13\mu\text{F}$. At 10kHz only 0.16 μF is needed.

For fixed voltage devices, and adjustable devices without an adjust pin capacitor, the output ripple will increase as the ratio of the output voltage to the reference voltage (V_{OUT}/V_{REF}). For example, with the output voltage equal to 5V, the output ripple will be increased by the ratio of 5V/1.25V. It will increase by a factor of four. Ripple rejection will be degraded by 12dB from the value shown on the curve.

Typical application circuits

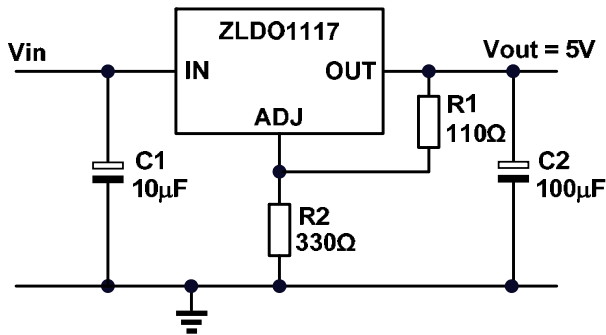

Using

$$V_{OUT} = 1.25 \cdot \left\{ 1 + \frac{R2}{R1} \right\}$$

then the output voltage becomes:

$$V_{OUT} = 1.25 \cdot \left\{ 1 + \frac{330}{110} \right\} = 5.0V$$

Figure 1 Basic adjustable regulator with 5V output

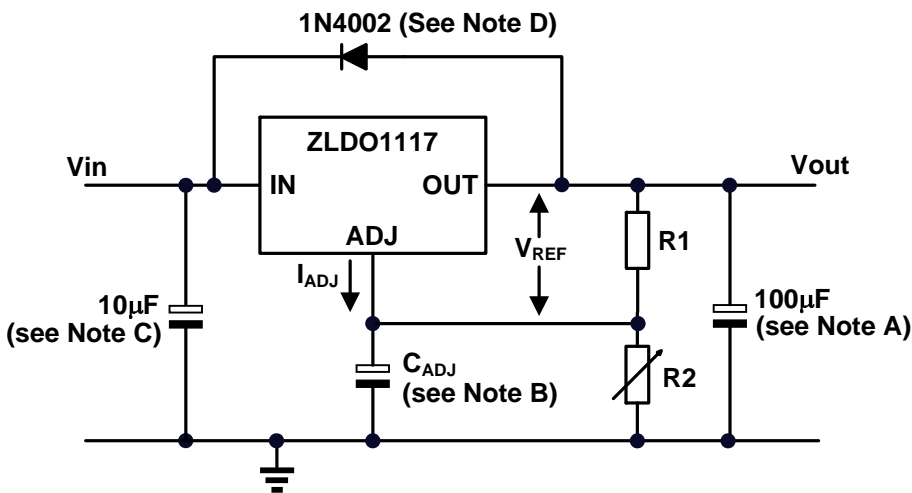

Figure 2 Adjustable regulator with I_{ADJ} errors

$$V_{OUT} = 1.25 \cdot \left\{ 1 + \frac{R2}{R1} \right\} + I_{ADJ} \cdot R2$$

Because I_{ADJ} typically is 55µA, its effect is negligible in most applications.

$$V_{OUT} = 1.25 \cdot \left\{ 1 + \frac{330}{110} + 55 \cdot 10^{-6} \cdot 330 \right\} = 5.02V \sim 0.4\%$$

- A. Output capacitor selection is critical for regulator stability. Larger C_{out} values benefit the regulator by improving transient response and loop stability.
- B. C_{ADJ} can be used to improve ripple rejection. If C_{ADJ} is used, a C_{out} that is larger in value than C_{ADJ} must be used.
- C. C_{in} is recommended if ZLDO1117 is not located near the power supply filter.
- D. An external diode is recommended to protect the regulator if the input instantaneously is shorted to GND.
- E. This device is designed to be stable with tantalum and MLCC capacitors with an ESR less than 0.47Ω.

Other typical circuits

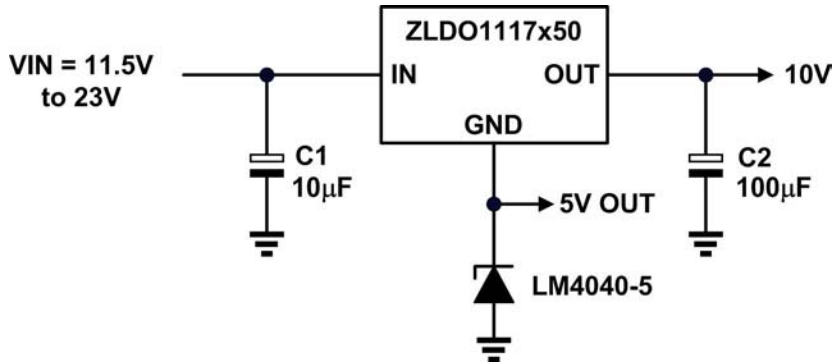

Figure 3 ZLDO1117 with extended output voltage

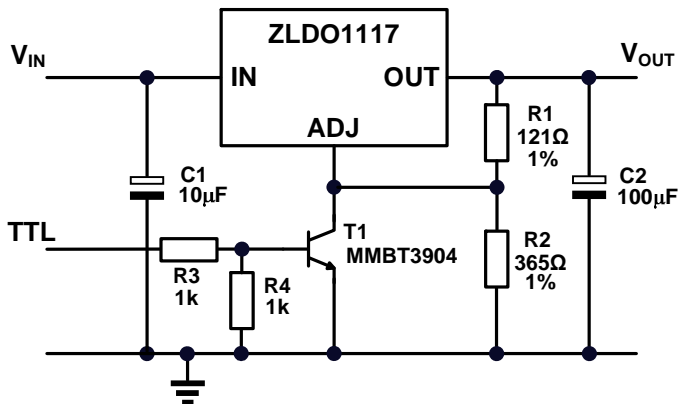

Figure 4 ZLDO1117 with disable function

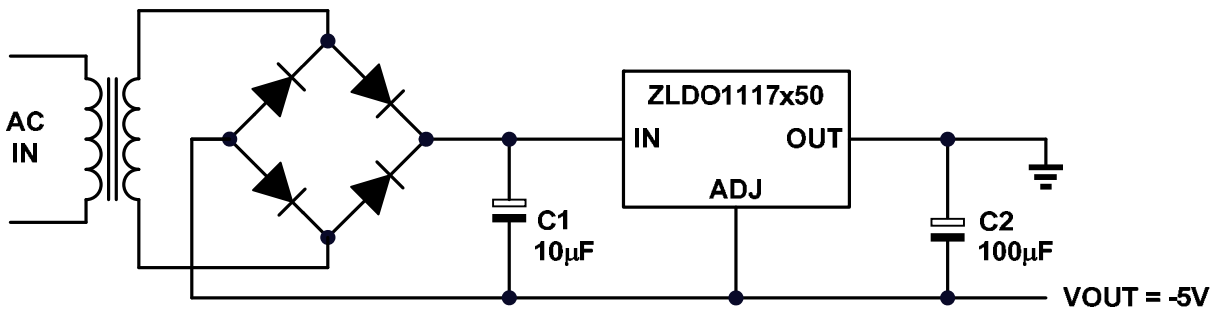

Figure 5 ZLDO1117 as a negative LDO

Ordering information

Device	Output voltage	Packaging (Note 3)	Status	Reel Quantity	Tape width	Reel size
ZLDO1117K12TC	1.2V	TO252-3L	Preview	2500	16 mm	13"
ZLDO1117G12TA		SOT223-3L	Preview	1000	12 mm	7"
ZLDO1117KTC	Adjustable	TO252-3L	Active	2500	16 mm	13"
ZLDO1117GTA		SOT223-3L	Active	1000	12 mm	7"
ZLDO1117K15TC	1.5V	TO252-3L	Active	2500	16 mm	13"
ZLDO1117G15TA		SOT223-3L	Active	1000	12 mm	7"
ZLDO1117K18TC	1.8V	TO252-3L	Active	2500	16 mm	13"
ZLDO1117G18TA		SOT223-3L	Active	1000	12 mm	7"
ZLDO1117K25TC	2.5V	TO252-3L	Active	2500	16 mm	13"
ZLDO1117G25TA		SOT223-3L	Active	1000	12 mm	7"
ZLDO1117K33TC	3.3V	TO252-3L	Active	2500	16 mm	13"
ZLDO1117G33TA		SOT223-3L	Active	1000	12 mm	7"
ZLDO1117K50TC	5.0V	TO252-3L	Active	2500	16 mm	13"
ZLDO1117G50TA		SOT223-3L	Active	1000	12 mm	7"

Notes: 1. EU Directive 2002/95/EC (RoHS). All applicable RoHS exemptions applied, see *EU Directive 2002/95/EC Annex Notes*.
2. Pad layout as shown on Diodes Inc. suggested pad layout document ZLDO02001, which can be found on our website at <http://www.diodes.com/datasheets/ap02001.pdf>.

Package outlines

SOT223

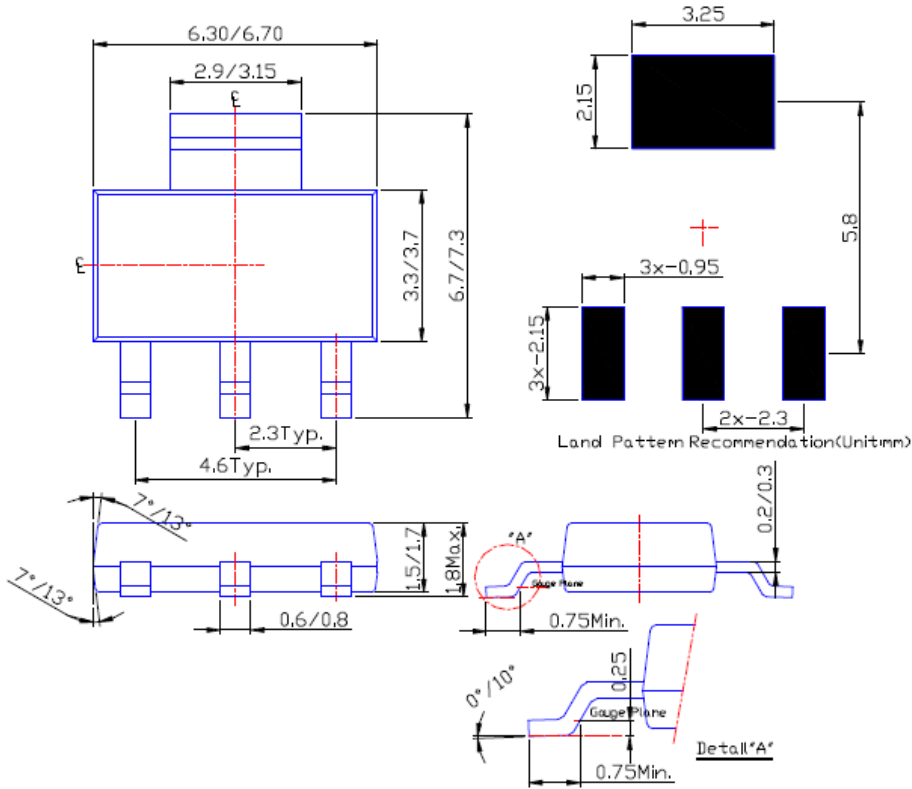

TO252

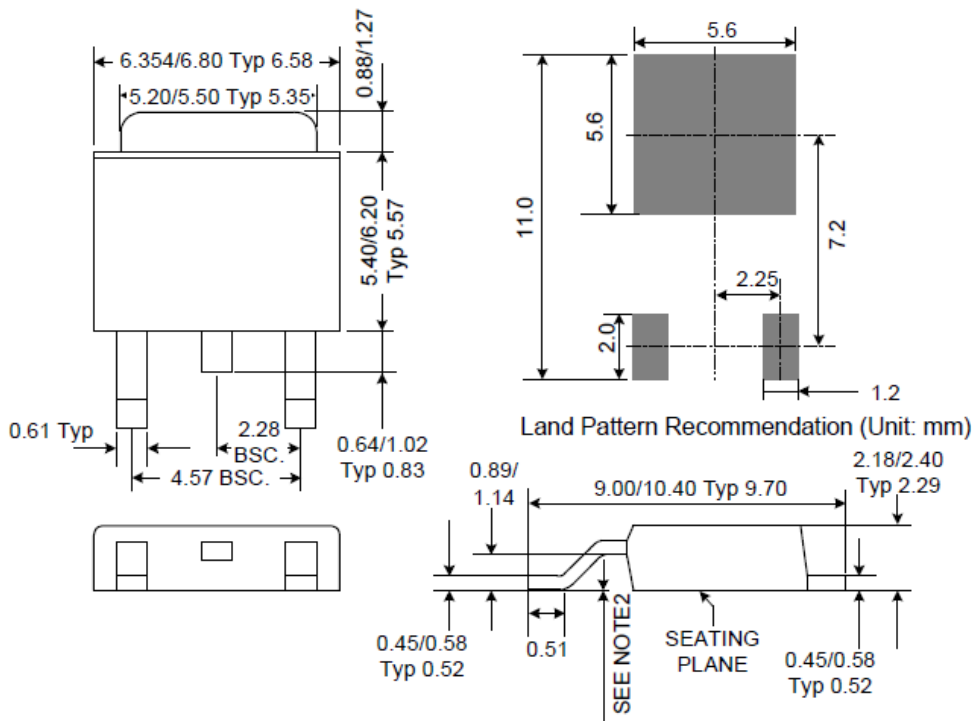

IMPORTANT NOTICE

DIODES INCORPORATED MAKES NO WARRANTY OF ANY KIND, EXPRESS OR IMPLIED, WITH REGARDS TO THIS DOCUMENT, INCLUDING, BUT NOT LIMITED TO, THE IMPLIED WARRANTIES OF MERCHANTABILITY AND FITNESS FOR A PARTICULAR PURPOSE (AND THEIR EQUIVALENTS UNDER THE LAWS OF ANY JURISDICTION).

Diodes Incorporated and its subsidiaries reserve the right to make modifications, enhancements, improvements, corrections or other changes without further notice to this document and any product described herein. Diodes Incorporated does not assume any liability arising out of the application or use of this document or any product described herein; neither does Diodes Incorporated convey any license under its patent or trademark rights, nor the rights of others. Any Customer or user of this document or products described herein in such applications shall assume all risks of such use and will agree to hold Diodes Incorporated and all the companies whose products are represented on Diodes Incorporated website, harmless against all damages.

Diodes Incorporated does not warrant or accept any liability whatsoever in respect of any products purchased through unauthorized sales channel.

Should Customers purchase or use Diodes Incorporated products for any unintended or unauthorized application, Customers shall indemnify and hold Diodes Incorporated and its representatives harmless against all claims, damages, expenses, and attorney fees arising out of, directly or indirectly, any claim of personal injury or death associated with such unintended or unauthorized application.

Products described herein may be covered by one or more United States, international or foreign patents pending. Product names and markings noted herein may also be covered by one or more United States, international or foreign trademarks.

LIFE SUPPORT

Diodes Incorporated products are specifically not authorized for use as critical components in life support devices or systems without the express written approval of the Chief Executive Officer of Diodes Incorporated. As used herein:

A. Life support devices or systems are devices or systems which:

1. are intended to implant into the body, or
2. support or sustain life and whose failure to perform when properly used in accordance with instructions for use provided in the labeling can be reasonably expected to result in significant injury to the user.

B. A critical component is any component in a life support device or system whose failure to perform can be reasonably expected to cause the failure of the life support device or to affect its safety or effectiveness.

Customers represent that they have all necessary expertise in the safety and regulatory ramifications of their life support devices or systems, and acknowledge and agree that they are solely responsible for all legal, regulatory and safety-related requirements concerning their products and any use of Diodes Incorporated products in such safety-critical, life support devices or systems, notwithstanding any devices- or systems-related information or support that may be provided by Diodes Incorporated. Further, Customers must fully indemnify Diodes Incorporated and its representatives against any damages arising out of the use of Diodes Incorporated products in such safety-critical, life support devices or systems.

Copyright © 2009, Diodes Incorporated

www.diodes.com