

# SUPPLY VOLTAGE MONITOR

ISSUE 3 – JULY 2006

**ZSM330**

## DEVICE DESCRIPTION

The ZSM330 is a three terminal under voltage monitor circuit for use in microprocessor systems. The threshold voltage of the device has been set to 3.1 volts making it ideal for 3.3 volt circuits.

Included in the device is a precise voltage reference and a comparator with built in hysteresis to prevent erratic operation. The ZSM330 features an open collector output capable of sinking at least 10mA which only requires a single external resistor to interface to following circuits.

Operation of the device is guaranteed from one volt upwards, from this level to the device threshold voltage the output is held low providing a power on reset function. Should the supply voltage, once established, at any time drop below the threshold level then the output again will pull low.

The device is available in a TO92 package for through hole applications as well as SOT223 for surface mount requirements.

## FEATURES

- SOT223 and TO92 packages
- Power on reset generator
- Automatic reset generation
- Low standby current
- Guaranteed operation from 1 volt
- Wide supply voltage range
- Internal clamp diode to discharge delay capacitor
- 3.1 volt threshold for 3.3 volt logic
- 20mV hysteresis prevents erratic operation

## APPLICATIONS

- Microprocessor systems
- Computers
- Computer peripherals
- Instrumentation
- Automotive
- Battery powered equipment

## SCHEMATIC DIAGRAM

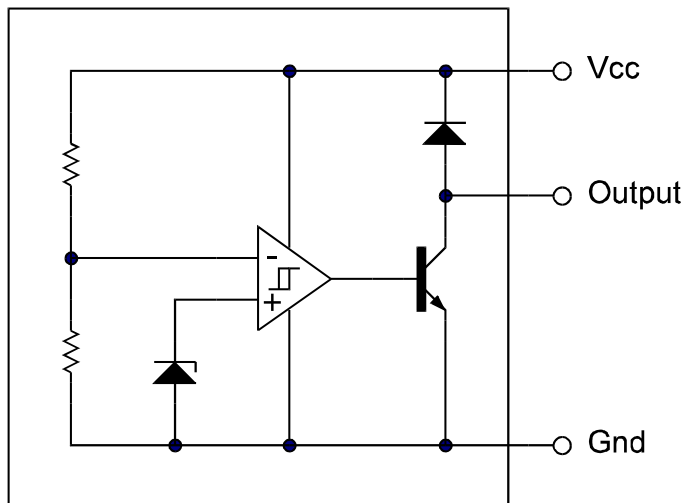

# ZSM330

## ABSOLUTE MAXIMUM RATING

Input Supply Voltage	-1 to 10V
Offstate Output Voltage	10V
Onstate Output Sink Current(Note 1)	Internally limited
Clamp Diode Forward Current(Note 1)	100mA
Operating Junction Temperature	150°C
Operating Temperature	-40 to 85°C
Storage Temperature	-55 to 150°C

## Power Dissipation

TO92	780mW
SOT223	2W(Note 2)

## TEST CONDITIONS

( $T_{amb}=25^{\circ}\text{C}$  for typical values,  $T_{amb}=-40$  to  $85^{\circ}\text{C}$  for min/max values (Note3))

## COMPARATOR

PARAMETER	SYMBOL	MIN	TYP.	MAX.	UNITS
Threshold Voltage High state output ( $V_{cc}$ increasing)	$V_{IH}$	3.01	3.09	3.15	V
Threshold Voltage Low state output ( $V_{cc}$ decreasing)	$V_{IL}$	3.01	3.07	3.15	V
Hysteresis	$V_H$	0.01	0.02	0.05	V

## OUTPUT

Output sink saturation: ( $V_{cc}=2.7\text{V}$ , $I_{sink}=8.0\text{mA}$ ) ( $V_{cc}=2.7\text{V}$ , $I_{sink}=2.0\text{mA}$ ) ( $V_{cc}=1.0\text{V}$ , $I_{sink}=0.1\text{mA}$ )	$V_{OL}$		0.46 0.15	1.0 0.4 0.25	V V V
Onstate output sink current ( $V_{cc}$ , Output=2.7V)	$I_{sink}$	10	27	60	mA
Offstate output leakage current ( $V_{cc}$ , Output=3.3V)	$I_{oh}$		0.02	0.5	$\mu\text{A}$
Clamp diode forward voltage ( $I_f=10\text{mA}$ )	$V_f$	0.6	1.2	1.5	V
Propagation delay ( $V_{in}$ 3.3V to 2.7V, $R_I=10\text{k}$ , $T_{amb}=25^{\circ}\text{C}$ )	$T_d$		2.2		$\mu\text{s}$

## TOTAL DEVICE

Operating input voltage range	$V_{cc}$	1.0 to 6.5			V
Quiescent input current ( $V_{cc}=3.3\text{V}$ )	$I_q$		120	180	$\mu\text{A}$

### Note:

1. Maximum package power dissipation must be observed
2. Maximum power dissipation, for the SOT223 package is calculated assuming that the device is mounted on a PCB measuring 2 inches square.
3. Low duty cycle pulse techniques are used during test to maintain junction temperatures as close to ambient as possible

# ZSM330

## TYPICAL CHARACTERISTICS

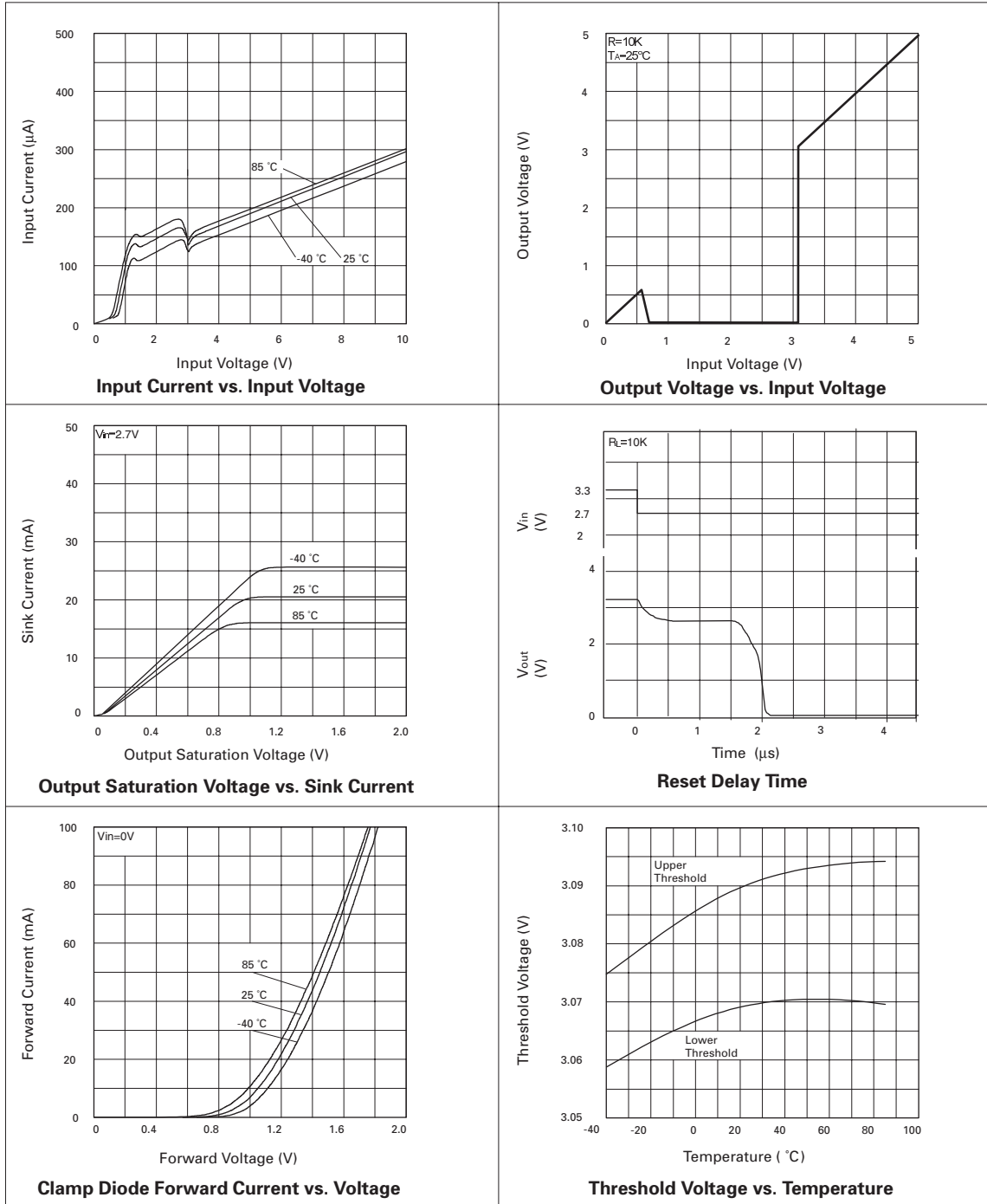

# ZSM330

## TIMING DIAGRAM

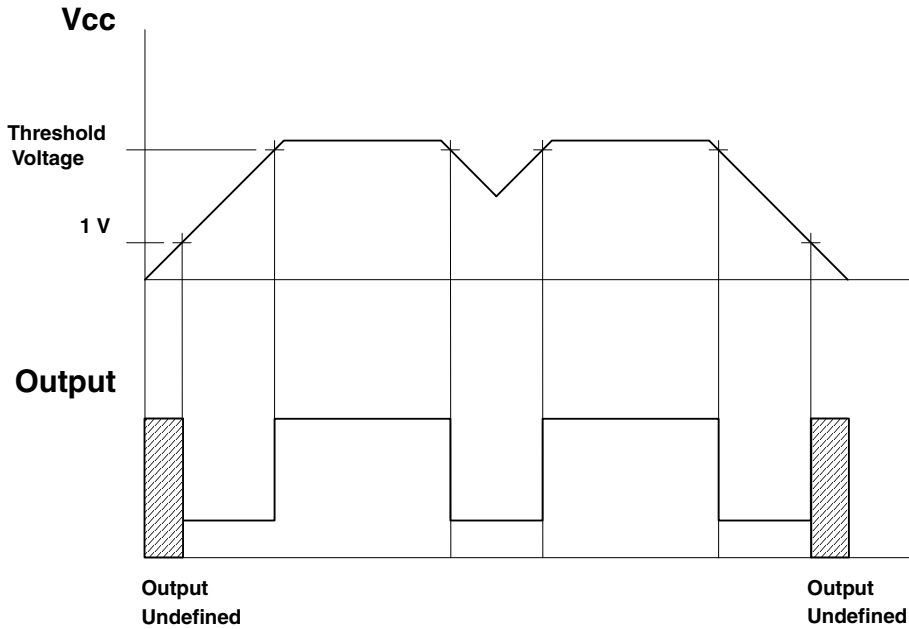

## APPLICATION CIRCUIT

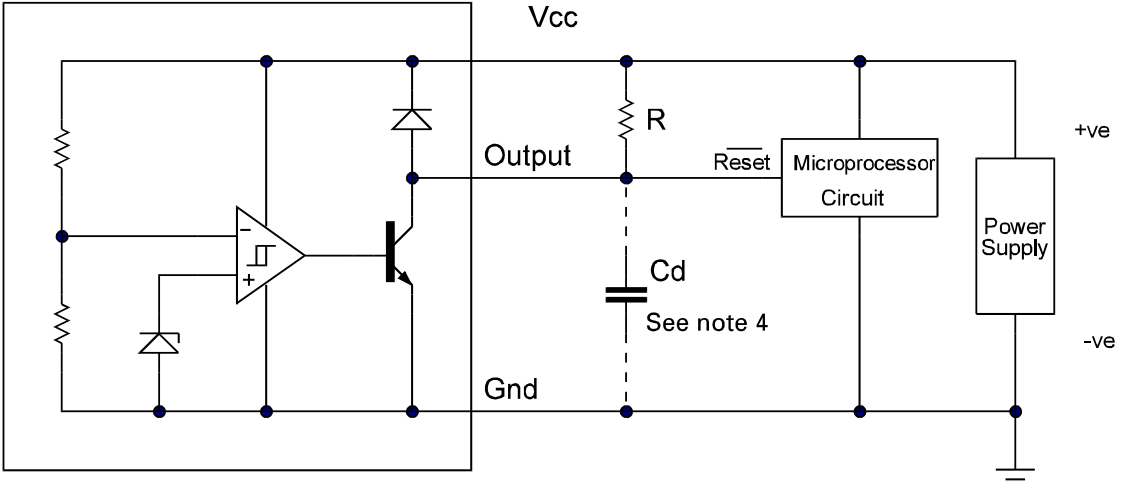

Note 4: A time delayed reset can be accomplished with the additional Cd.

$$T_{DY} = RCd \ln \left( \frac{1}{1 - \frac{V_{TH}(mpu)}{V_{in}}} \right)$$

$T_{DY}$  = Time (Seconds)  
 $V_{TH}$  = Microprocessor Reset Threshold  
 $V_{in}$  = Power Supply Voltage

# ZSM330

## CONNECTION DIAGRAMS

### TO92 Package Suffix – C

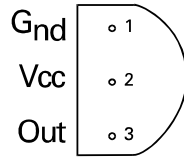

Bottom View

### SOT223 Package Suffix – G

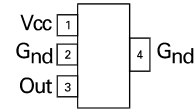

Top View –  
Pin 4 floating or connected to pin 2

## ORDERING INFORMATION

Part Number	Package	Part Mark
ZSM330G	SOT223	ZSM330
ZSM330C	TO92	ZSM330

### Europe

Zetex GmbH  
Streitfeldstraße 19  
D-81673 München  
Germany

Telephone: (49) 89 45 49 49 0  
Fax: (49) 89 45 49 49 49  
europe.sales@zetex.com

### Americas

Zetex Inc  
700 Veterans Memorial Highway  
Hauppauge, NY 11788  
USA

Telephone: (1) 631 360 2222  
Fax: (1) 631 360 8222  
usa.sales@zetex.com

### Asia Pacific

Zetex (Asia Ltd)  
3701-04 Metroplaza Tower 1  
Hing Fong Road, Kwai Fong  
Hong Kong

Telephone: (852) 26100 611  
Fax: (852) 24250 494  
asia.sales@zetex.com

### Corporate Headquarters

Zetex Semiconductors plc  
Zetex Technology Park, Chadderton  
Oldham, OL9 9LL  
United Kingdom

Telephone: (44) 161 622 4444  
Fax: (44) 161 622 4446  
hq@zetex.com

For international sales offices visit [www.zetex.com/offices](http://www.zetex.com/offices)

Zetex products are distributed worldwide. For details, see [www.zetex.com/salesnetwork](http://www.zetex.com/salesnetwork)

This publication is issued to provide outline information only which (unless agreed by the company in writing) may not be used, applied or reproduced for any purpose or form part of any order or contact or be regarded as a representation relating to the products or services concerned. The company reserves the right to alter without notice the specification, design, price or conditions of supply of any product or service.

Issue 3 - July 2006

© Zetex Semiconductors plc 2006

[www.zetex.com](http://www.zetex.com)